

T E N T A T I V E

No. _____
DATE 01. Nov. 2002

STK621-018

OUTLINE · This IC is a 3-phase inverter power hybrid IC containing power elements (IGBT and FRD), pre-driver, overcurrent protection circuit.

APPLICATION · 3-phase inverter motor drive

FEATURES · Integrates power elements (IGBT and FRD), pre-driver, and protective circuit.

- Protective circuits including overcurrent (bus line), and pre-drive low voltage protection are built in.
- Direct input of CMOS level control signals without an insulating circuit (photocoupler, etc) is possible.
- A single power supply drive is enabled through the use of bootstrap circuits for upper power supplies. (externally set)
- Built-in simultaneous upper/lower ON prevention circuit to prevent arm shorting through simultaneous ON input for the upper and lower side transistors. (Dead time is required for preventing shorting due to switching delay.)
- SIP (The single in-line package) of the transferfull mold structure.

Absolute MAXIMUM RATINGS/T_c=25° C

Item	Symbol	Rating	Unit	Conditions
Supply voltage	V _{CC}	450	V	Between +-- , surge <500V
Collector-emitter voltage	V _{CE}	600	V	Between +-U(V, W) or U(V, W)--
Output current	I _O	±3	A	+, -, U, V, W terminal current
Output peak current	I _{OP}	±8	A	+, -, U, V, W terminal current PW=100uSec
Pre-driver voltage	V _{D1, 2, 3, 4}	20	V	between V _{B1-U} , V _{B2-V} , V _{B3-W} , V _D -V _{SS} *1
Input signal voltage	V _{IN}	0~7	V	H _{IN1, 2, 3} , L _{IN1, 2, 3} terminal
FAULT terminal voltage	V _{FAULT}	20	V	FAULT terminal
Maximum power loss	P _d	10	W	IGBT/1channel
Junction temperature	T _j	150	°C	IGBT, FRD
Storage temperature	T _{stg}	-40~+125	°C	
Operating temperature	T _C	-20~+100	°C	H-IC case temperature
Tightening torque	M _T	1.0	N · m	A screw part

In the case without the instruction, the voltage standard is - terminal = V_{SS} terminal voltage.

*1 V_{D1}= between V_{B1-U}、V_{D2}=V_{B2-V}、V_{D3}=V_{B3-W}、V_{D4}=V_D-V_{SS}, terminal voltage.

www.DataSheet.in

Specifications and information herein are subject to change without notice.

TENTATIVE

Electric characteristics / $T_c=25^\circ\text{C}$, $V_D=15\text{V}$

Parameter	Symbol	Condition	Circuit	min.	typ.	Max.	unit
Power output part							
Collector-to-emitter cut off current	I_{CE}	$V_{CE}=600\text{V}$	Fig. 1	—	—	2	mA
Collector-to-emitter saturation voltage	$V_{CE(SAT)}$	$I_o=3\text{A}$ upper ch	Fig. 2	—	2.2	2.8	V
		$I_o=3\text{A}$ lower ch		—	2.4	3.0	
Diode forward voltage	V_F	$I_o=-3\text{A}$ upper ch	Fig. 3	—	1.7	2.3	V
		$I_o=-3\text{A}$ lower ch		—	1.9	2.5	
Junction to case thermal resistance	$\theta_{j-c(T)}$	IGBT	—	—	10	—	$^\circ\text{C/W}$
	$\theta_{j-c(D)}$	FWD	—	—	12	—	
Control (pre-driver) part							
Control power supply consumption electric current	I_D	$V_{D1,2,3}=15\text{V}$	Fig. 4	—	0.05	1	mA
		$V_{D4}=15\text{V}$		—	2	10	
Input ON voltage	V_{IH}	Output ON	—	—	—	0.8	V
Input OFF voltage	V_{IL}	Output OFF	—	3.0	—	—	V
Protection part							
Over current	I_{SD}	$P.W.=100\mu\text{S}$	Fig. 5	3	—	5	A
Low voltage protection	U_{VLO}		—	10	—	12	V
Input fault current	I_{oSD}	$V_{FAULT}=1.0\text{V}$	—	—	2	—	mA
Fault clear time	$FLCLR$		—	6	9	12	mS
Switching time							
Switching time	t_{ON}	$I_o=3\text{A}$	Fig. 6	0.5	1.0	—	μS
	t_{OFF}	Inductive load		—	1.2	2.0	
Current signal output	I_{so}	$I_o=3\text{A}$	—	0.34	0.36	0.38	V

Without instructions, the voltage standards is $- (=V_{SS})$ terminal.

*Notes

- Input ON voltage indicates a value to turn on output stage IGBT.
Input OFF voltage indicates a value to turn off output stage IGBT.
At the time of output ON, set the input signal voltage 0V to V_{IH} (MAX).
At the time of output OFF, set the input signal voltage V_{IL} (MIN) to 5V .
- When the internal protection circuit operates, there is FAULT signal ON (When the FAULT terminal is low level, FAULT signal is ON state : output form is open DRAIN) but the FAULT signal doesn't latch. After protection operation ending, it returns automatically within about 9 ms and it becomes an operation beginning condition. So, after FAULT signal detection, set OFF (HIGH) to all input signals at once.
But, the operation of pre-drive power supply low voltage protection (UVLO: it has a hysteresis about 0.3V) is as follows.
Upper side → There is not FAULT signal output but it does a corresponding gate signal OFF. Incidentally, it returns to the regular operation when recovering to the normal voltage but the latch continues among input signal ON (Low).

* Notes

Lower side → It outputs FAULT signal with gate signal OFF.

However, it different from the protection operation of upper side, it is automatically reset about 9 ms later and becomes an operation beginning condition when recovering to the normal voltage. (The protection operation doesn't latch by the input signal.)

3. When assembling the hybrid IC on the heat sink, tightening torque range is 0.8N·m to 1.0N·m.

Circuit Block Diagram

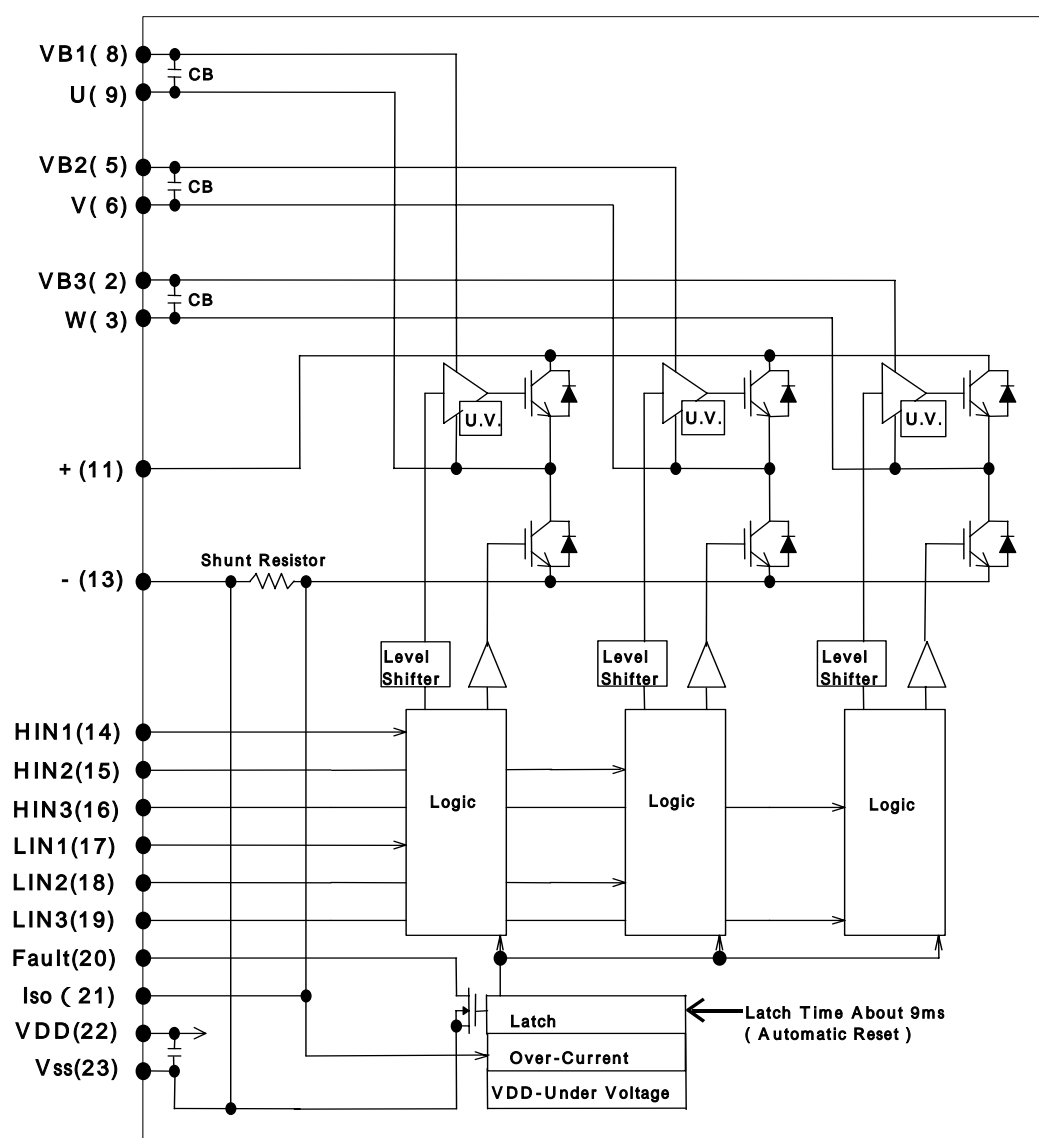

Test Circuit

Fig 1 : I_{CE}

	U+	V+	W+	U-	V-	W-
M	11	11	11	9	6	3
N	9	6	3	13	13	13

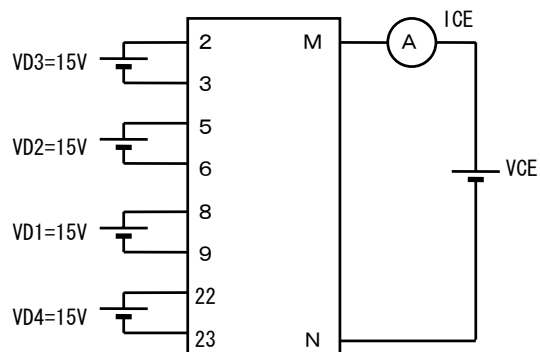

Fig 2 : V_{CE(SAT)}

	U+	V+	W+	U-	V-	W-
M	11	11	11	9	6	3
N	9	6	3	13	13	13
m	14	15	16	17	18	19

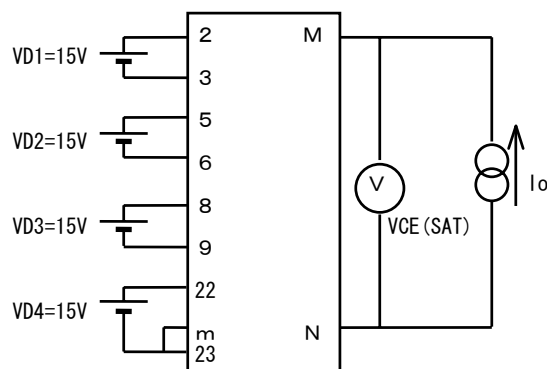

Fig 3 : V_F

	U+	V+	W+	U-	V-	W-
M	11	11	11	9	6	3
N	9	6	3	13	13	13

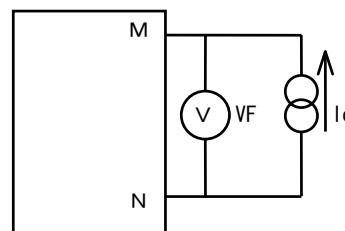
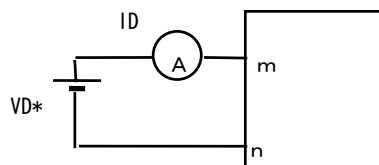

Fig 4 : I_D

	VD1	VD2	VD3	VD4
m	8	5	2	22
n	9	6	3	23



Test Circuit

Fig5 : I SD (Ex. Lower U phase)

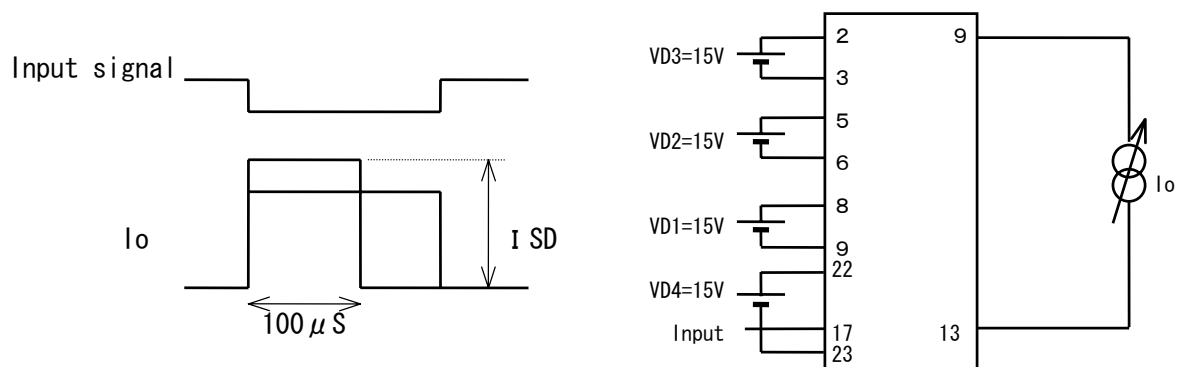
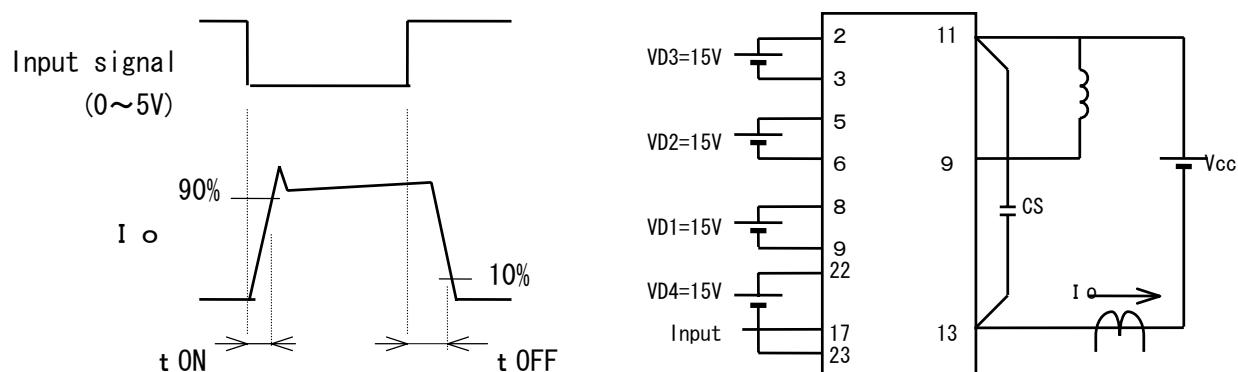
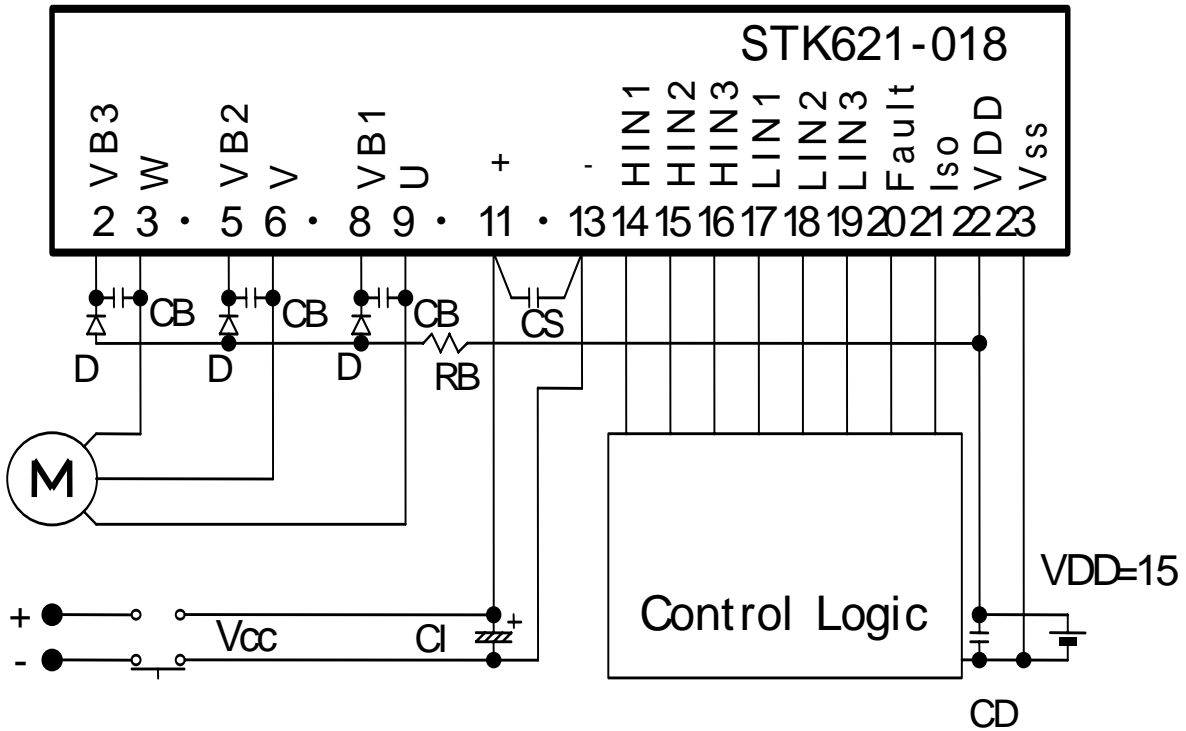

Fig6 : Switching time (Ex. Lower U phase)



Application Circuit



Recommended Operating Conditions

Item	Symbol	Conditions	Min.	Typ.	Max.	Unit
Supply Voltage	Vcc	Between + & -	0	280	400	V
Pre-Driver	VD1, 2, 3	Between VB & VS	12.5	15	17.5	V
Supply Voltage	VD4	Between VDD & Vss	13.5	15	16.5	
ON-state Input Voltage	V IN (ON)	HIN1, HIN2, HIN3,	0	—	0.3	V
OFF-state Input voltage	V IN (OFF)	LIN1, LIN2, LIN3 Terminal	3.5	—	5	
PWM Frequency	f PWM		1	—	20	KHZ
Deadtime	D T	turn-off to turn-on	2	—	—	μs
Tightening Torque	M T	'M 3' Type Screw	0.8	—	1.0	N·m

Usage Precautions

1. By the addition of the diode for the bootstrap (DB : high speed type, withstand voltage equal to or more than 600V) and of the capacitor (CB : about 1 to 47 μ F), a single power supply drive is enabled. In this case, it makes a lower side IGBT ON (input signal of lower side makes LOW). Then it charges in CB. Incidentally, in case of start-up and so on, when the voltage of CB is low, the big charging electric current flows and sometimes becomes the cause which exerts the bad influence of the noise and so on. Put limitation resistance RB (Several Ω to about tens of Ω). (When not using bootstrap circuit, each upper side pre-drive power supply needs an independent power supply. Externally set.) Also, the upper side power supply voltage sometimes declines by the way of controlling. Confirm it
2. Because the jump voltage which is accompanied by the vibration in case of switching operation occurs by the influence of the floating inductance of the wiring of the outer power supply which is connected with of the + terminal and the - terminal, restrains and spares surge voltage being as the connection of the snubber circuit (Capacitor / CS / about 0.1 - 10 μ F) for the voltage absorption with the neighborhood as possible between + and the - terminal, and so on, with making a wiring length (among the terminals each from Cl) short and making a wiring inductance small.
3. Iso terminal (20pin) is for the electric current monitor. Be careful, because the overcurrent protection does not operate when short-circuiting in the Iso terminal and the Vss terminal.
4. Output form of the FAULT terminal is open DRAIN (it is operating as FAULT when becoming LOW). When the pull up with the resistance, use above 5.6K Ω .
5. The overcurrent protection feature operates only when it is possible to do a circuit control normally. For the safety, put a fuse, and so on in the Vcc line.
6. Because the IC sometimes destroys and bursts when motor connection terminal (3pin, 6pin, 9pin) becomes open while the motor turns, especially, be careful of the connection (the soldering condition) of this terminal.

This data shows the example of the application circuit, does not guarantee a design as the mass.

PACKAGE DIMENSION

SCALE	1/1	UNIT	mm
-------	-----	------	----

<TENTATIVE>

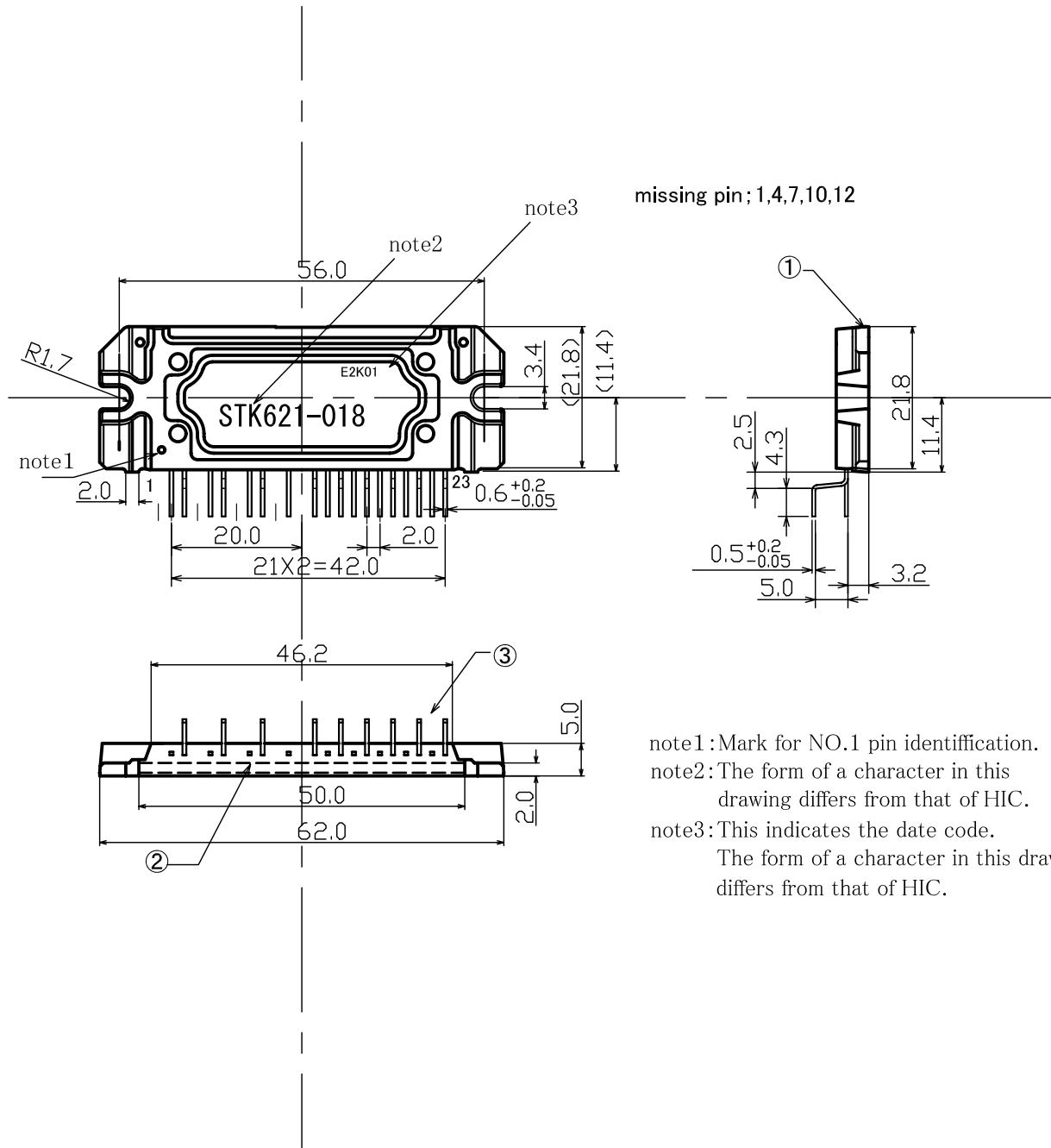

note1 : Mark for NO.1 pin identification.
 note2 : The form of a character in this drawing differs from that of HIC.
 note3 : This indicates the date code.
 The form of a character in this drawing differs from that of HIC.

	PARTS NAME	MATERIAL	TREATMENT
①	CASE	EPOXY	
②	SUBSTRATE	IMST SUBSTRATE	
③	LEAD FRAME	Cu	COPPER/SOLDER PLATING

DO NOT SCALE THIS DRAWING

TOLERANCE UNLESS OTHERWISE SPECIFIED ±0.5

DRAWN.		DATE	Nov. /01/2002	NAME	STK621-018	PART NO.	
CHECK.		APPRO.		OUTLINE			