



STK800

N-channel 30V - 0.006Ω - 20A - PolarPAK[®]
STripFET[™] Power MOSFET

General features

Type	V _{DSS}	R _{DS(on)}	R _{DS(on)} *Q _g	P _{TOT}
STK800	30V	<0.0078Ω	80.4nC*mΩ	5.2W

- Ultra low top and bottom junction to case thermal resistance
- Very low capacitances
- 100% R_g tested
- Fully encapsulated die
- In compliance with the 2002/95/EC european directive

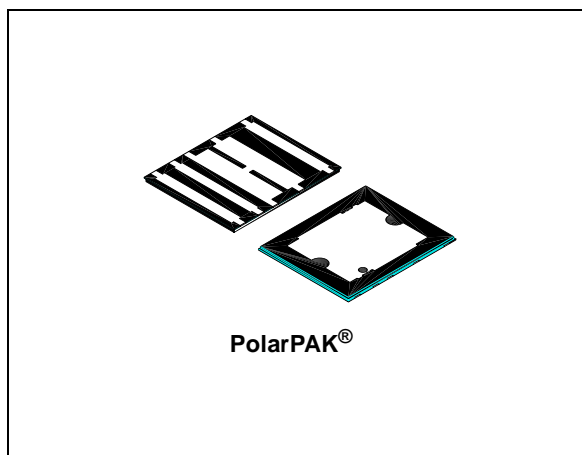

Description

This Power MOSFET is the latest development of STMicroelectronics unique “Single Feature Size[™]” strip-based process. The resulting transistor shows extremely high packing density for low on-resistance, moreover the double sides cooling package with ultra low junction to case thermal resistance allows to handle higher levels of current.

Applications

- Switching application

Internal schematic diagram

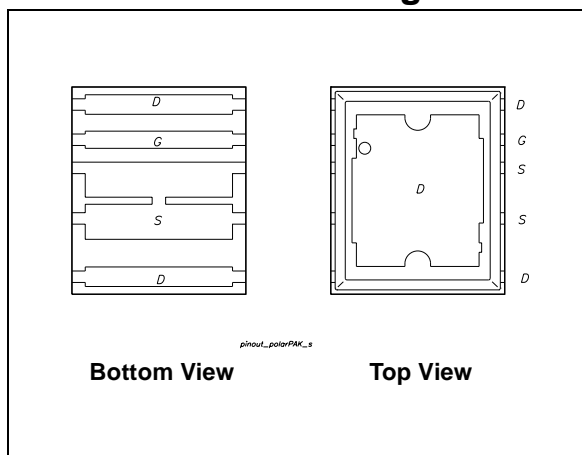

Order codes

Part number	Marking	Package	Packaging
STK800	K800	PolarPAK [®]	Tape & reel

Contents

1	Electrical ratings	3
2	Electrical characteristics	4
	2.1 Electrical characteristics (curves)	6
3	Test circuit	8
4	Package mechanical data	9
5	Revision history	11

1 Electrical ratings

Table 1. Absolute maximum ratings

Symbol	Parameter	Value	Unit
V_{DS}	Drain-source voltage ($V_{GS} = 0$)	30	V
$V_{GS}^{(1)}$	Gate-source voltage	± 16	V
$V_{GS}^{(2)}$	Gate-source voltage	± 18	V
$I_D^{(4)}$	Drain current (continuous) at $T_C = 25^\circ\text{C}$	20	A
I_D	Drain current (continuous) at $T_C = 100^\circ\text{C}$	12.5	A
$I_{DM}^{(3)}$	Drain current (pulsed)	80	A
$P_{TOT}^{(4)}$	Total dissipation at $T_C = 25^\circ\text{C}$	5.2	W
	Derating factor	0.0416	W/ $^\circ\text{C}$
T_j T_{stg}	Operating junction temperature Storage temperature	-55 to 150	$^\circ\text{C}$

1. Continuous mode
2. Guaranteed for test time $\leq 15\text{ms}$
3. Pulse width limited by package
4. When mounted on FR-4 board of 1inch^2 , 2 oz Cu and $\leq 10\text{sec}$

Table 2. Thermal data

Symbol	Parameter	Typ.	Max.	Unit
$R_{thj-amb}^{(1)}$	Thermal resistance junction-amb	20	24	$^\circ\text{C}/\text{W}$
$R_{thj-c}^{(2)}$	Thermal resistance junction-case (top drain)	1	1.2	$^\circ\text{C}/\text{W}$
$R_{thj-c}^{(3)}$	Thermal resistance junction-case (source)	2.8	3.4	$^\circ\text{C}/\text{W}$

1. When mounted on FR-4 board of 1inch^2 , 2 oz Cu and $\leq 10\text{sec}$
2. Steady State
3. Measured at Source pin when the device is mounted on FR-4 board in steady state

2 Electrical characteristics

($T_{CASE}=25^{\circ}C$ unless otherwise specified)

Table 3. On/off states

Symbol	Parameter	Test conditions	Min.	Typ.	Max.	Unit
$V_{(BR)DSS}$	Drain-source breakdown voltage	$I_D = 250\mu A, V_{GS} = 0$	30			V
I_{DSS}	Zero gate voltage drain current ($V_{GS} = 0$)	$V_{DS} = \text{Max rating},$ $V_{DS} = \text{Max rating}, T_c = 125^{\circ}C$			1 10	μA μA
I_{GSS}	Gate body leakage current ($V_{DS} = 0$)	$V_{GS} = \pm 16V$			± 100	nA
$V_{GS(th)}$	Gate threshold voltage	$V_{DS} = V_{GS}, I_D = 250\mu A$	1		2.5	V
$R_{DS(on)}$	Static drain-source on resistance	$V_{GS} = 10V, I_D = 10A$ $V_{GS} = 4.5V, I_D = 10A$		0.006 0.0075	0.0078 0.0098	Ω Ω

Table 4. Dynamic

Symbol	Parameter	Test conditions	Min.	Typ.	Max.	Unit
$g_{fs}^{(1)}$	Forward transconductance	$V_{DS} = 15V, I_D = 10 A$		44		S
C_{iss}	Input capacitance	$V_{DS} = 25V, f = 1 \text{ MHz}, V_{GS} = 0$		1380		pF
C_{oss}	Output capacitance			450		pF
C_{rss}	Reverse transfer capacitance			75		pF
Q_g	Total gate charge	$V_{DD} = 15V, I_D = 20A$		13.4		nC
Q_{gs}	Gate-source charge	$V_{GS} = 4.5V$		3.4		nC
Q_{gd}	Gate-drain charge	(see Figure 14)		4.5		nC

1. Pulsed: pulse duration = 300 μs , duty cycle 1.5%

Table 5. Switching times

Symbol	Parameter	Test conditions	Min.	Typ.	Max.	Unit
$t_{d(on)}$ t_r	Turn-on delay time Rise time	$V_{DD}=15V$, $I_D=10A$, $R_G=4.7\Omega$, $V_{GS}=4.5V$ (see Figure 15)		15 50		ns ns
$t_{d(off)}$ t_f	Turn-off delay time Fall time	$V_{DD}=15V$, $I_D=10A$, $R_G=4.7\Omega$, $V_{GS}=4.5V$ (see Figure 15)		45 15		ns ns

Table 6. Source drain diode

Symbol	Parameter	Test conditions	Min.	Typ.	Max.	Unit
I_{SD} $I_{SDM}^{(1)}$	Source-drain current Source-drain current (pulsed)				20 80	A A
$V_{SD}^{(2)}$	Forward on Voltage	$I_{SD}=20A$, $V_{GS}=0$			1.2	V
t_{rr} Q_{rr} I_{RRM}	Reverse recovery time Reverse recovery charge Reverse recovery current	$I_{SD}=20A$, $di/dt=100A/\mu s$, $V_{DD}=20V$, $T_j=150^\circ C$ (see Figure 15)		32 28.8 1.8		ns nC A

1. Pulse width limited by package
2. Pulsed: pulse duration = 300 μs , duty cycle 1.5%

2.1 Electrical characteristics (curves)

Figure 1. Safe operating area

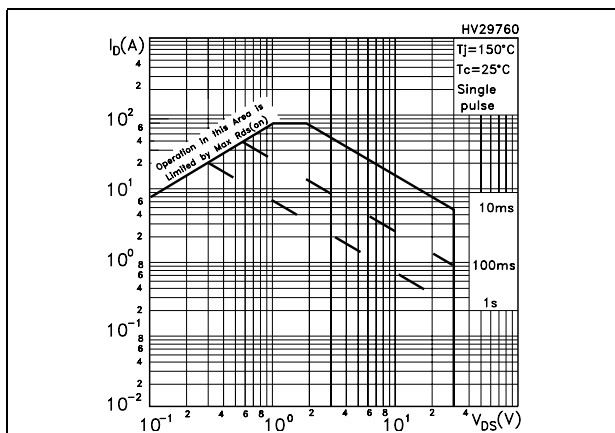

Figure 2. Thermal impedance

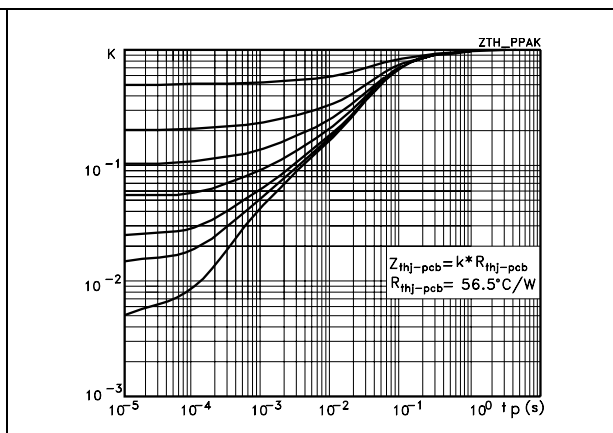

Figure 3. Output characteristics

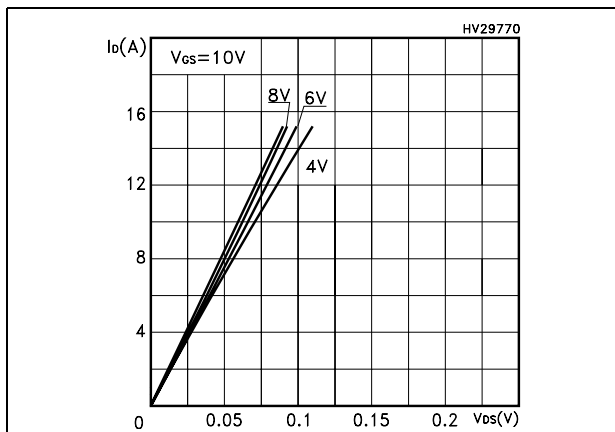

Figure 4. Transfer characteristics

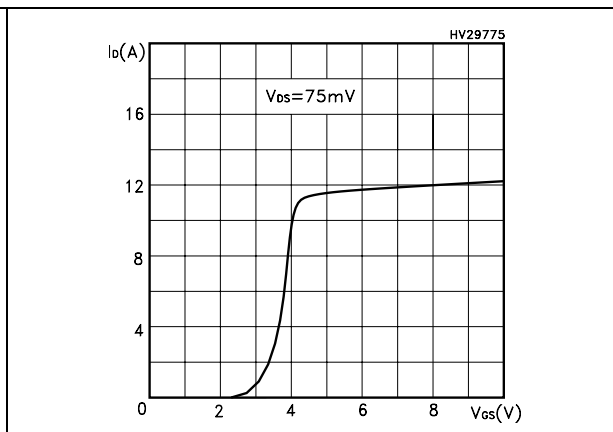

Figure 5. Transconductance

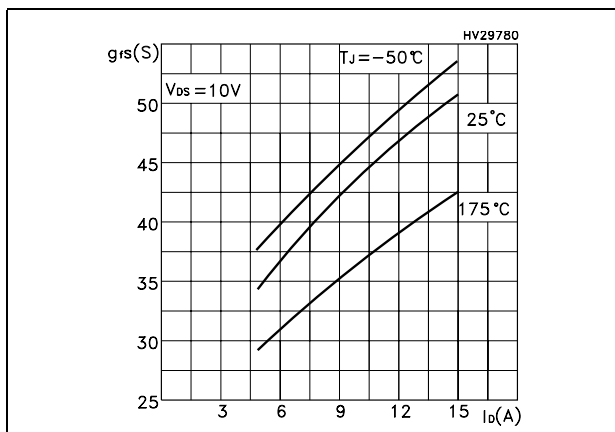

Figure 6. Static drain-source on resistance

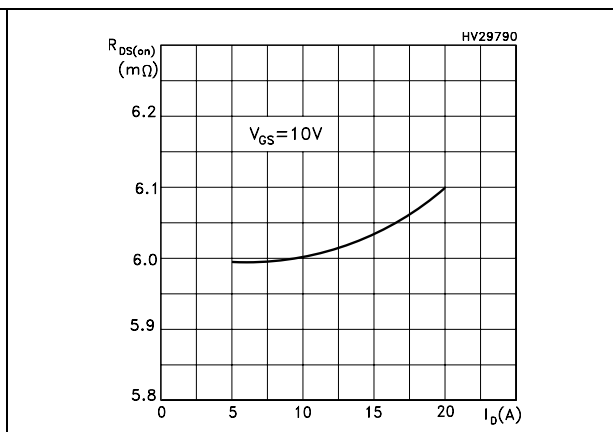

Figure 7. Gate charge vs gate-source voltage Figure 8. Capacitance variations

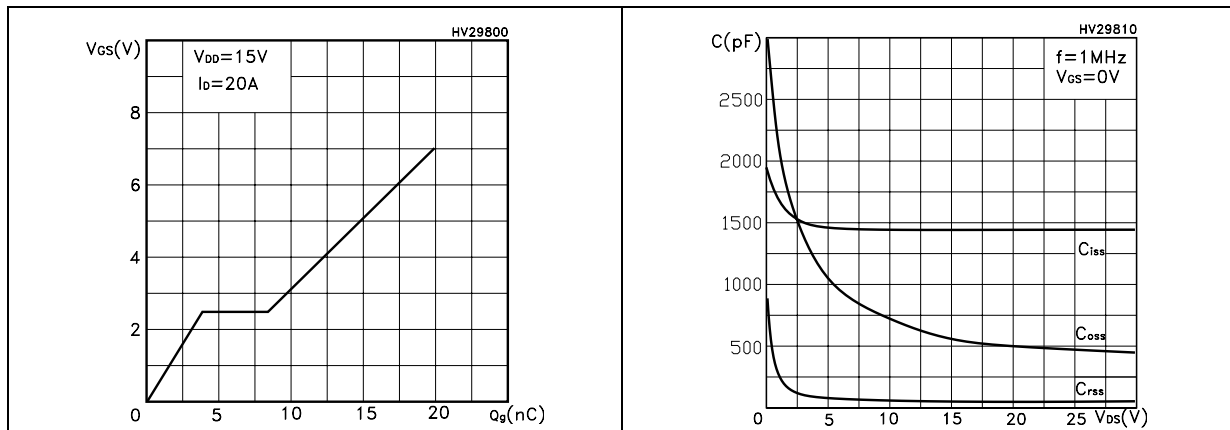

Figure 9. Normalized gate threshold voltage vs temperature Figure 10. Normalized on resistance vs temperature

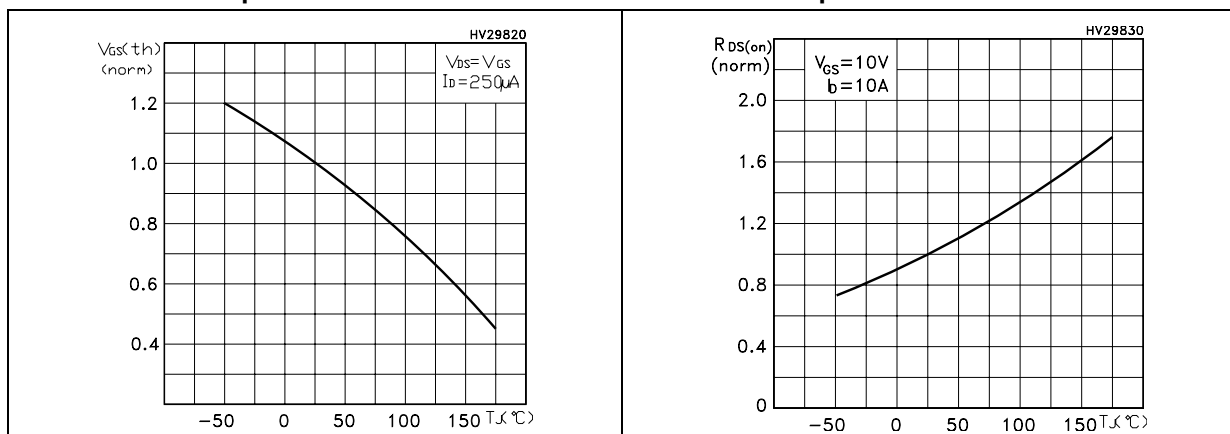
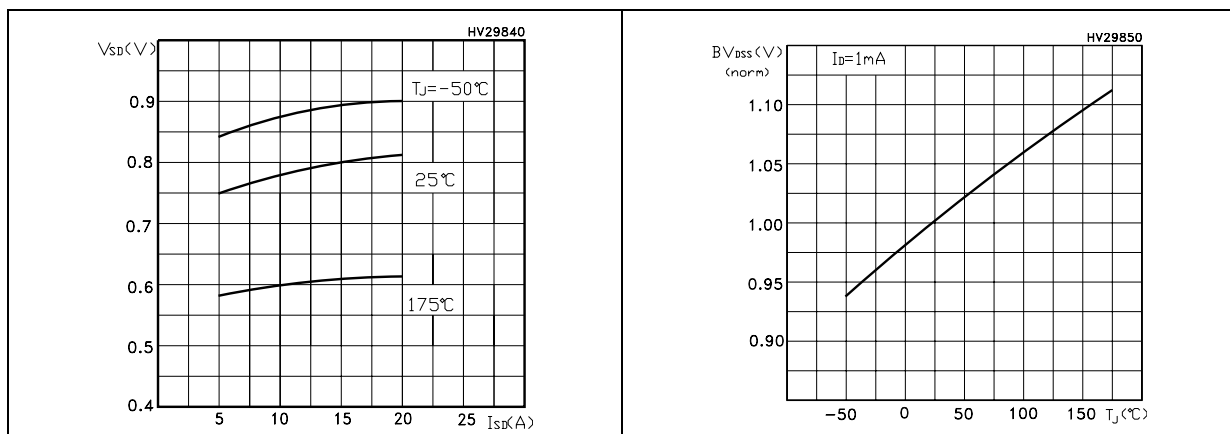

Figure 11. Source-drain diode forward characteristics Figure 12. Normalized $B_{V_{DS}}$ vs temperature



3 Test circuit

Figure 13. Switching times test circuit for resistive load

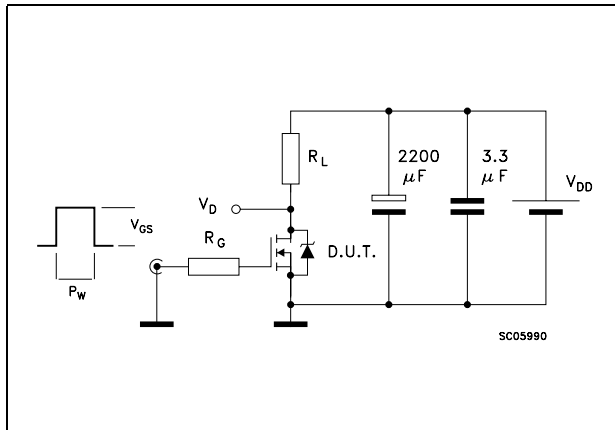

Figure 14. Gate charge test circuit

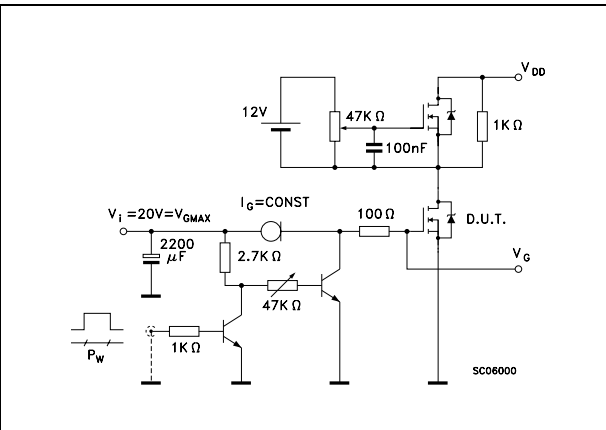

Figure 15. Test circuit for inductive load switching and diode recovery times

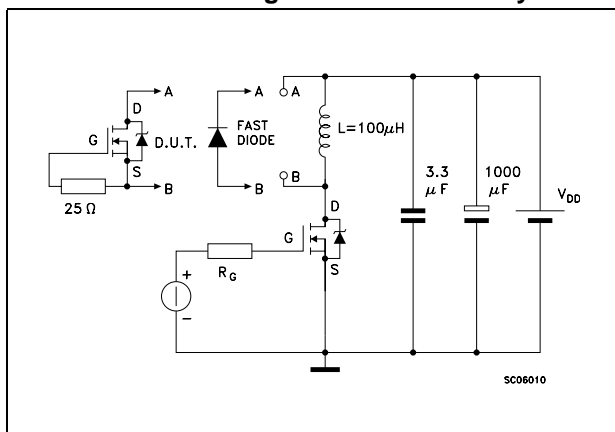

Figure 16. Unclamped inductive load test circuit

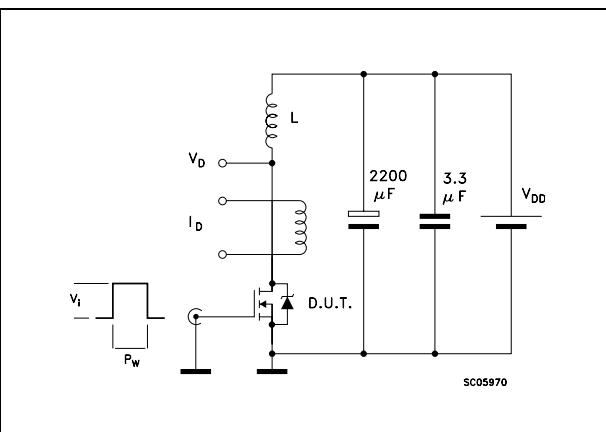

Figure 17. Unclamped inductive waveform

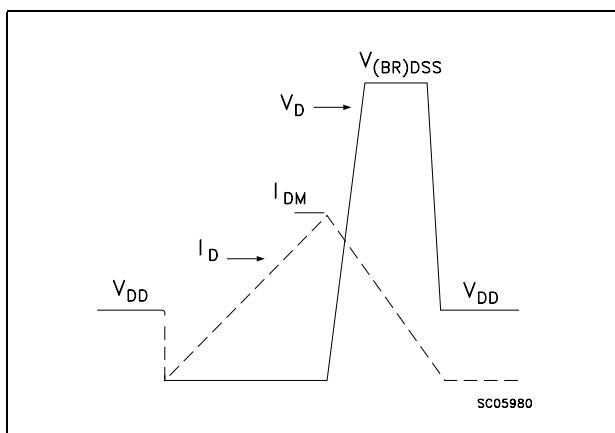
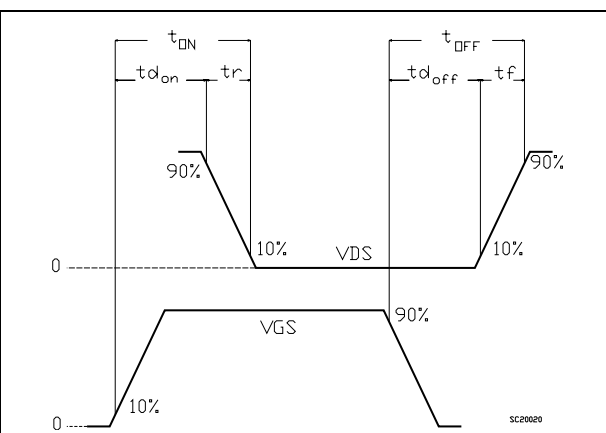

Figure 18. Switching time waveform



4 Package mechanical data

In order to meet environmental requirements, ST offers these devices in ECOPACK® packages. These packages have a Lead-free second level interconnect . The category of second level interconnect is marked on the package and on the inner box label, in compliance with JEDEC Standard JESD97. The maximum ratings related to soldering conditions are also marked on the inner box label. ECOPACK is an ST trademark. ECOPACK specifications are available at: www.st.com

PolarPAK® (Option "S") MECHANICAL DATA						
REF.	mm			inch		
	MIN.	TYP.	MAX.	MIN.	TYP.	MAX.
A	0.75	0.80	0.85	0.030	0.031	0.033
A1			0.05			0.002
b1	0.48	0.58	0.68	0.019	0.023	0.027
b2	0.41	0.51	0.61	0.016	0.020	0.024
b3	2.19	2.29	2.39	0.086	0.090	0.094
b4	0.89	1.04	1.19	0.035	0.041	0.047
b5	0.23	0.33	0.43	0.009	0.013	0.017
c	0.20	0.25	0.30	0.008	0.010	0.012
D	6	6.15	6.30	0.236	0.242	0.248
D1	5.74	5.89	6.04	0.226	0.232	0.238
E	5.01	5.16	5.31	0.197	0.203	0.209
E1	4.75	4.90	5.05	0.187	0.193	0.199
H1	0.23			0.009		
H2	0.45		0.56	0.020		0.022
H3	0.31	0.41	0.51	0.012	0.016	0.020
H4	0.45		0.56	0.020		0.022
K1	4.22	4.37	4.52	0.166	0.172	0.178
K4	0.24			0.009		
M1	4.30	4.50	4.70	0.169	0.177	0.185
M2	3.43	3.58	3.73	0.135	0.141	0.147
M3	0.22			0.009		
M4	0.05			0.002		
P1	0.15	0.20	0.25	0.006	0.008	0.010
T1	3.48	3.64	4.10	0.137	0.143	0.150
T2	0.56	0.76	0.95	0.022	0.030	0.037
T3	1.20			0.051		
T4	3.90			0.154		
T5		0.18	0.36		0.007	0.014
<	0°	10°	12°	0°	10°	12°

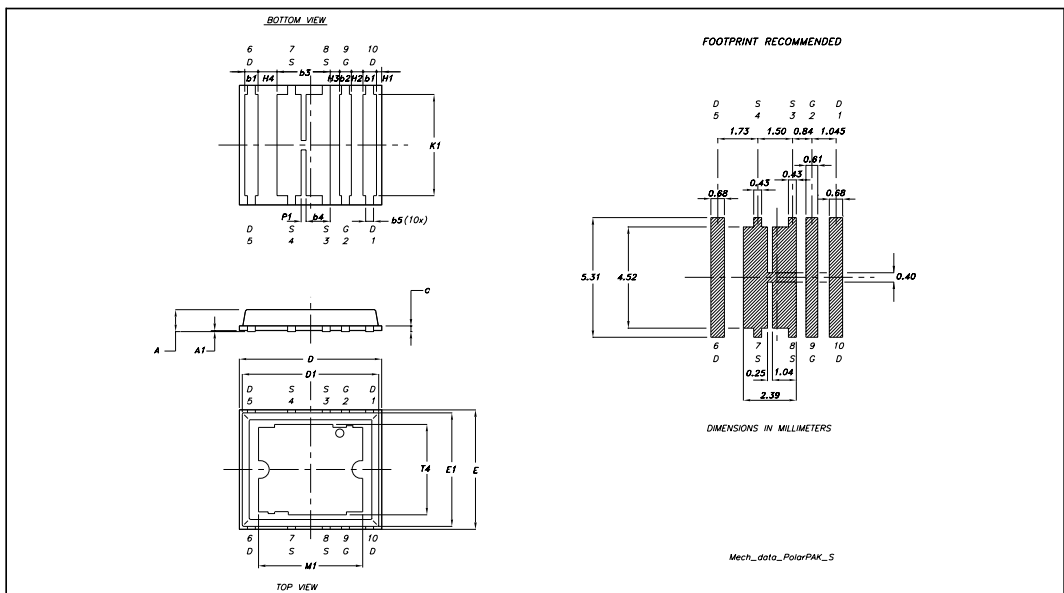

5 Revision history

Table 7. Revision history

Date	Revision	Changes
09-Nov-2005	1	First version
02-Feb-2006	2	Complete datasheet
21-Mar-2006	3	New template

Please Read Carefully:

Information in this document is provided solely in connection with ST products. STMicroelectronics NV and its subsidiaries ("ST") reserve the right to make changes, corrections, modifications or improvements, to this document, and the products and services described herein at any time, without notice.

All ST products are sold pursuant to ST's terms and conditions of sale.

Purchasers are solely responsible for the choice, selection and use of the ST products and services described herein, and ST assumes no liability whatsoever relating to the choice, selection or use of the ST products and services described herein.

No license, express or implied, by estoppel or otherwise, to any intellectual property rights is granted under this document. If any part of this document refers to any third party products or services it shall not be deemed a license grant by ST for the use of such third party products or services, or any intellectual property contained therein or considered as a warranty covering the use in any manner whatsoever of such third party products or services or any intellectual property contained therein.

UNLESS OTHERWISE SET FORTH IN ST'S TERMS AND CONDITIONS OF SALE ST DISCLAIMS ANY EXPRESS OR IMPLIED WARRANTY WITH RESPECT TO THE USE AND/OR SALE OF ST PRODUCTS INCLUDING WITHOUT LIMITATION IMPLIED WARRANTIES OF MERCHANTABILITY, FITNESS FOR A PARTICULAR PURPOSE (AND THEIR EQUIVALENTS UNDER THE LAWS OF ANY JURISDICTION), OR INFRINGEMENT OF ANY PATENT, COPYRIGHT OR OTHER INTELLECTUAL PROPERTY RIGHT.

UNLESS EXPRESSLY APPROVED IN WRITING BY AN AUTHORIZED REPRESENTATIVE OF ST, ST PRODUCTS ARE NOT DESIGNED, AUTHORIZED OR WARRANTED FOR USE IN MILITARY, AIR CRAFT, SPACE, LIFE SAVING, OR LIFE SUSTAINING APPLICATIONS, NOR IN PRODUCTS OR SYSTEMS, WHERE FAILURE OR MALFUNCTION MAY RESULT IN PERSONAL INJURY, DEATH, OR SEVERE PROPERTY OR ENVIRONMENTAL DAMAGE.

Resale of ST products with provisions different from the statements and/or technical features set forth in this document shall immediately void any warranty granted by ST for the ST product or service described herein and shall not create or extend in any manner whatsoever, any liability of ST.

ST and the ST logo are trademarks or registered trademarks of ST in various countries.

Information in this document supersedes and replaces all information previously supplied.

The ST logo is a registered trademark of STMicroelectronics. All other names are the property of their respective owners.

© 2006 STMicroelectronics - All rights reserved

STMicroelectronics group of companies

Australia - Belgium - Brazil - Canada - China - Czech Republic - Finland - France - Germany - Hong Kong - India - Israel - Italy - Japan - Malaysia - Malta - Morocco - Singapore - Spain - Sweden - Switzerland - United Kingdom - United States of America

www.st.com