

250mA Low Quiescent Current Linear Regulator

Low IQ Regulator

DESCRIPTION

The STL6340 series is a positive voltage regulator with high accuracy output voltage and ultra-low quiescent current which is typically 2.0µA. The device is ideal for handheld communication equipments and battery powered applications which require low quiescent current.

The STL6340 consists of a bandgap reference voltage source, an error amplifier, a P-channel pass transistor, a resistor-divider for setting output voltage, a current limiter, and temperature limit protection circuit. The high-accuracy output voltage is preset at an internally trimmed voltage 1.8V, 2.5V or 3.3V. Other output voltages can be maskoptioned from 1.2V to 5.0V with 100mV increment. (but only 1.28V in stead of 1.3V)

FEATURE

- ◆ Low Current Consumption: 2µA
- ◆ Short Circuit Protection: 200mA
- ◆ Low Dropout: 150mV@100mA ($V_{OUT} \geq 2.0V$)
- ◆ Operating Voltages Range: 1.8V to 6.0V
- ◆ Output Range: 1.2V to 5.0V with 100mV Increment
- ◆ Output Current Limit Protection: 350mA
- ◆ Thermal Overload Shutdown Protection
- ◆ High Ripple Rejection: 60dB
- ◆ Low ESR Capacitor Compatible

APPLICATIONS

- ◆ Battery Powered Equipment.
- ◆ Portable Information Application
- ◆ PDA
- ◆ MP3
- ◆ Digital Video Recorder

PIN CONFIGURATION

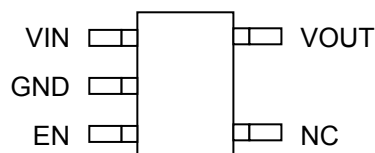

TOP VIEW
SOT-25

PART MARKING INFORMATION

<p>STL6340-<u>XX</u> <u>XX</u>-<u>XX</u> <u>X</u></p> <p style="margin-left: 40px;">└─ Lead Plating Code</p> <p style="margin-left: 30px;">└─ Handling Code</p> <p style="margin-left: 20px;">└─ Package Code</p> <p style="margin-left: 10px;">└─ Voltage Code</p> <p>Lead Plating Code G : Lead-free & Halogen-free product</p> <p>Handling Code TR : Tape&Reel</p> <p>Package Code S5 : SOT-25</p> <p>Voltage Code XX : 12 / 15 / 18 / 25 / 28 / 30 / 33</p>	<p>Marking:</p> <div style="border: 1px solid black; padding: 5px; width: fit-content; margin: 10px auto;">09VXX</div> <p style="text-align: center;">SOT-25</p> <p>09 : STL6340</p> <p>V : Voltage code 5:1.2V, 8:1.5V A:1.8V, G:2.5V K:2.8V, M:3.0V Q:3.3V</p> <p>XX : Date code</p>
---	--

ORDERING INFORMATION

Part Number SOT-25	Package Code	Package	VOUT Voltage	Shipping
STL6340-XXS5-TRG	S5	SOT-25	1.2	3000/Tape&Reel
			1.5	
			1.8	
			2.5	
			2.8	
			3.0	
			3.3	

Note:

※“XX”stands for output voltages.

※ G : Lead-free product. This product is RoHS compliant

ABSOLUTE MAXIMUM RATINGS ($T_A = 25^{\circ}\text{C}$ Unless otherwise noted)

Parameter	Symbol	Maximum	Unit
Power Dissipation	P_D	400	mW
Input voltage	V_{IN}	7.0	V
Output Current Limit	I_{OUT}	350	mA
Thermal resistance junction to case	θ_{JA}	155	$^{\circ}\text{C}/\text{W}$
Operating Ambient Temperature Range	T_J	-40~+125	$^{\circ}\text{C}$
Storage Temperature Range	T_{STG}	-55~+150	$^{\circ}\text{C}$
Lead Soldering Temperature	T_{LEAD}	+260	$^{\circ}\text{C}$

Note: The power dissipation values are based on the condition that temperature T_J and ambient temperature T_A difference is 100°C

Stresses beyond those listed under “absolute maximum rating” may cause permanent damage to the device.

These are stress rating only, and function operation of the device at these or any other conditions beyond those indicated under “recommended operating conditions” is not implied. Exposure to absolute-maximum-rated conditions for extended periods may affect device reliability.

ELECTRICAL CHARACTERISTICS ($T_A = 25^\circ\text{C}$ Unless otherwise noted)

 Operating conditions: $V_{IN}=5\text{V}$, $T_A=25^\circ\text{C}$, unless otherwise noted

Parameter	Symbol	Test Conditions	Min	Typ	Max	Unit
Input Voltage	V_{IN}	-	1.8	-	6.0	V
Output Voltage	V_{OUT}	$V_{IN}=V_{OUT}+1\text{V}$, $V_{OUT}\leq 2.5\text{V}$	-0.05	-	+0.05	V
		$V_{IN}=V_{OUT}+1\text{V}$, $V_{OUT}\geq 2.5\text{V}$	-2.0	-	+2.0	%
Line Regulation	V_{LINE}	$V_{OUT}+1\text{V}\leq V_{IN}\leq 6.0\text{V}$ $I_{OUT}=1\text{mA}$	-	0.1	0.2	%
Load Regulation	V_{LOAD}	$1\text{mA}\leq I_{OUT}\leq 100\text{mA}$	-	0.01	0.02	%
Dropout Voltage	V_{DROP}	$V_{OUT}\geq 2.0\text{V}$, $I_{OUT}=100\text{mA}$		150	200	mV
EN Pin Input Voltage "H"	V_{IH}	-	1.0	-	-	V
EN Pin Input Voltage "L"	V_{IL}	-	-	-	0.3	V
Output Current (1)	I_{OUT}		250	-	-	mA
Quiescent Current	I_Q	$V_{IN}=V_{OUT}+1\text{V}$, $I_{LOAD}=0$	-	2.0	4.5	μA
EN Pin Leakage Current	I_{EN}			0.05	0.1	μA
Thermal Shutdown Temperature	T_{SD}	-	-	155	-	$^\circ\text{C}$
Thermal Shutdown Hysteresis	T_{HYS}	-	-	10	-	$^\circ\text{C}$
Output Voltage Temperature Coefficient	T_C	$I_{OUT}=1\text{mA}$, $-40^\circ\text{C}\leq T_A\leq 80^\circ\text{C}$	-	100	-	ppm $^\circ\text{C}$
Ripple Rejection Ratio	R_A	$f=100\text{Hz}$, $C_{OUT}=1\mu\text{F}$	-	60	-	dB
Output Noise	θ_N	$f=10\text{KHz}$, $C_{OUT}=1\mu\text{F}$	-	150	-	μV

NOTES: (1) Measured using a double sided board with 1 x 2 square inches of copper area connected to the GND pin for "heat spreading".

FUNCTION BLOCK DIAGRAM

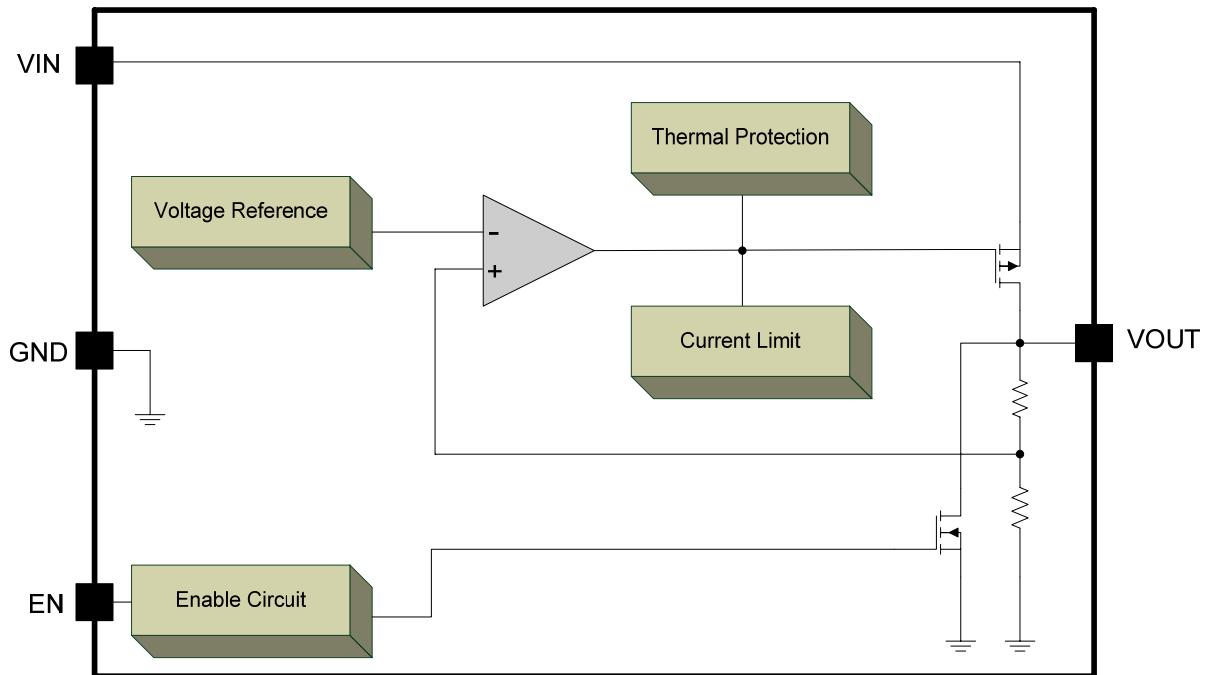

TYPICAL APPLICATIONS

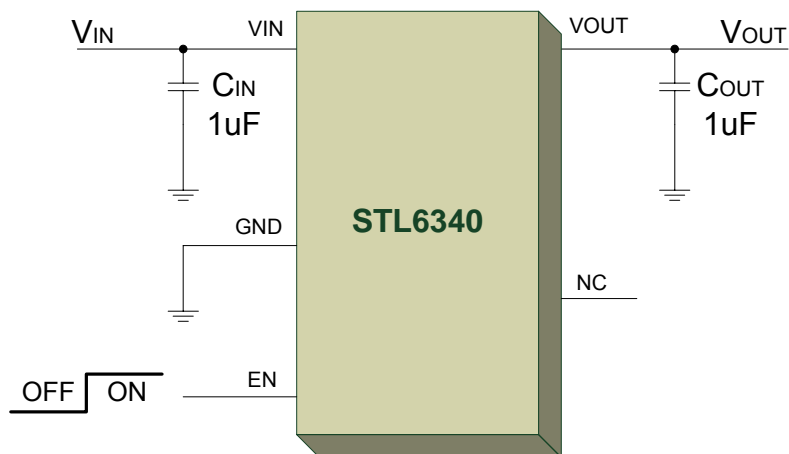

APPLICATION INFORMATION

◆Detail Description

The STL6340 is a low quiescent current LDO linear regulator. The device provides preset 1.8V, 2.5V and 3.3V output voltages for output current up to 350mA. Other mask options for special output voltages from 1.2V to 5.0V with 100mV increment are also available (but only 1.28V in stead of 1.3V). As illustrated in function block diagram, it consists of a 1.23V reference, error amplifier, a P-channel pass transistor, an ON/OFF control logic, and an internal feedback voltage divider.

The 1.23V bandgap reference is connected to the error amplifier, which compares this reference with the feedback voltage and amplifies the voltage difference. If the feedback voltage is lower than the reference voltage, the pass-transistor gate is pulled lower, which allows more current to pass to the output pin and increases the output voltage. If the feedback voltage is too high, the pass-transistor gate is pulled up to decrease the output voltage.

The output voltage is feedback through an internal resistive divider connected to V_{OUT} pin. Additional blocks include with output current limiter and shutdown logic.

◆Internal P-channel Pass Transistor

The STL6340 features a P-channel MOSFET pass transistor. Unlike similar designs using PNP pass transistors, P-channel MOSFETs require no base drive, which reduces quiescent current. PNP-based regulators also waste considerable current in dropout conditions when the pass transistor saturates, and use high base-drive currents under large loads. The STL6340 does not suffer from these problems and consumes only 2.0 μ A (Typical) of current consumption under light loads.

◆Enable Function

EN pin starts and stops the regulator. When the EN pin is switched to the power off level, the operation of all internal circuit stops, the build-in P-channel MOSFET output transistor between pins V_{IN} and V_{OUT} is switched off, allowing current consumption to be drastically reduced. The V_{OUT} pin enters the GND level due to the several M Ω resistance of the feedback voltage divider between V_{OUT} and GND pins.

◆Output Voltage Selection

The STL6340 output voltage is preset at an internally trimmed voltage 1.8V, 2.5V or 3.3V. The output voltage also can be mask-optioned from 1.2V to 5.0V with 100mV increment by special order (but

only 1.28V in stead of 1.3V). The first two digits of part number suffix identify the output voltage (see *Ordering Information*). For example, STL6340-33 has a preset 3.3V output voltage.

◆Current Limit

The STL6340 also includes a fold back current limiter. It monitors and controls the pass-transistor's gate voltage, estimates the output current, and limits the output current within 350mA.

◆Thermal Overload Protection

Thermal overload protection limits total power dissipation in the STL6340. When the junction temperature exceeds $T_J = +155^\circ\text{C}$, a thermal sensor turns off the pass transistor, allowing the IC to cool down. The thermal sensor turns the pass transistor active again after the junction temperature cools down by 10°C , resulting in a pulsed output during continuous thermal overload conditions.

Thermal overload protection is designed to protect the STL6340 in the event of fault conditions. For continuous operation, the maximum operating junction temperature rating of $T_J = +125^\circ\text{C}$ should not be exceeded.

◆Dropout Voltage

A regulator's minimum input-output voltage differential, or dropout voltage, determines the lowest usable supply voltage. In battery-powered systems, this will determine the useful end-of-life battery voltage. The STL6340 uses a P-channel MOSFET pass transistor, its dropout voltage is a function of drain-to-source on-resistance ($R_{DS(ON)}$) multiplied by the load current.

$$V_{DROPOUT} = V_{IN} - V_{OUT} = R_{DS(ON)} \times I_{OUT}$$

■ TYPICAL CHARACTERISTICS (25°C Unless Note)

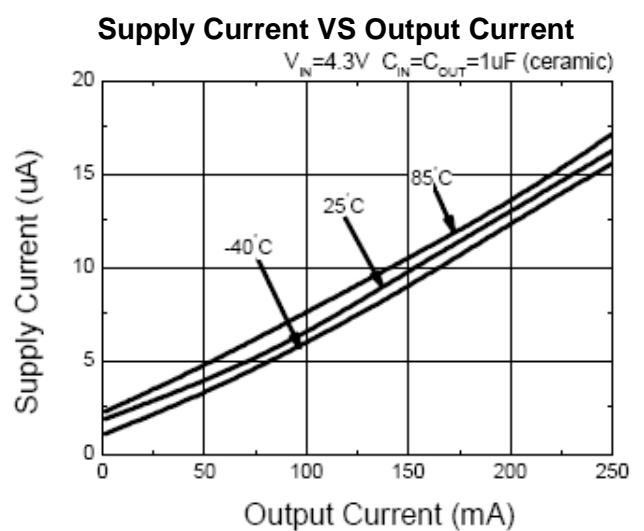
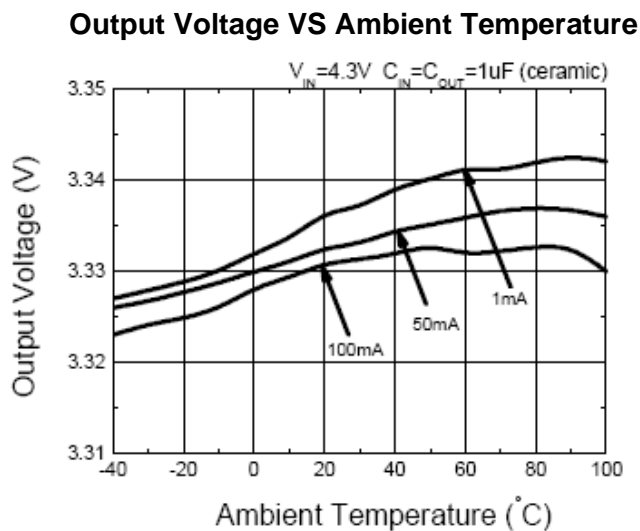
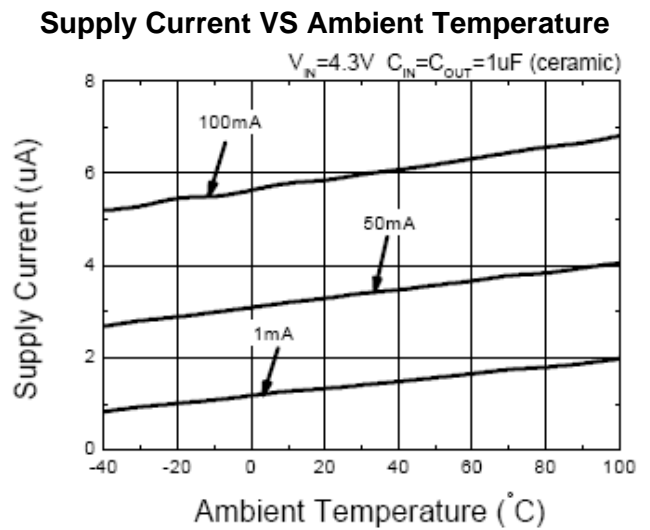
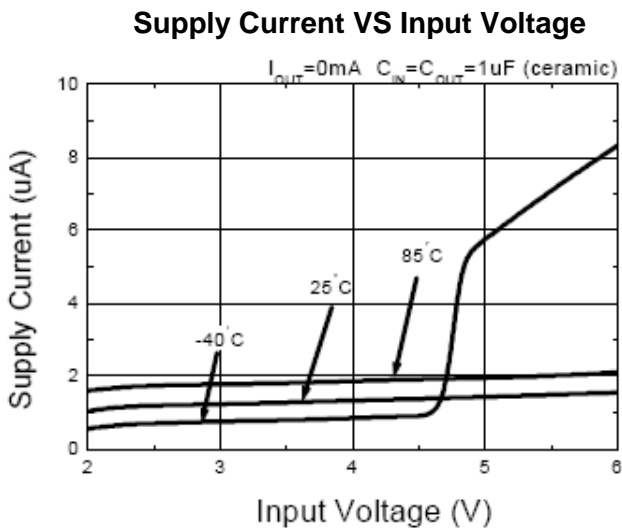
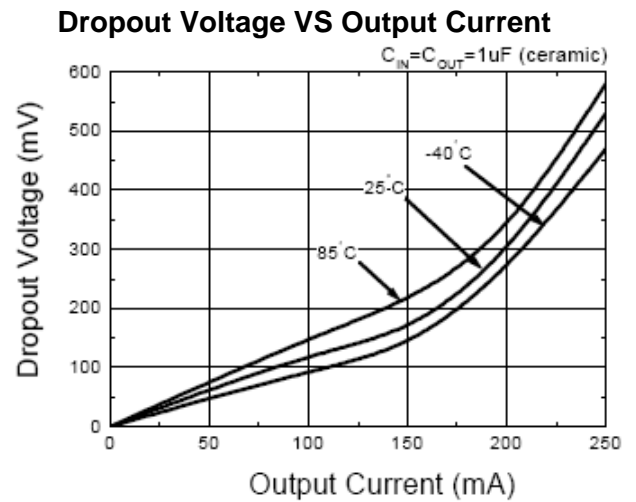
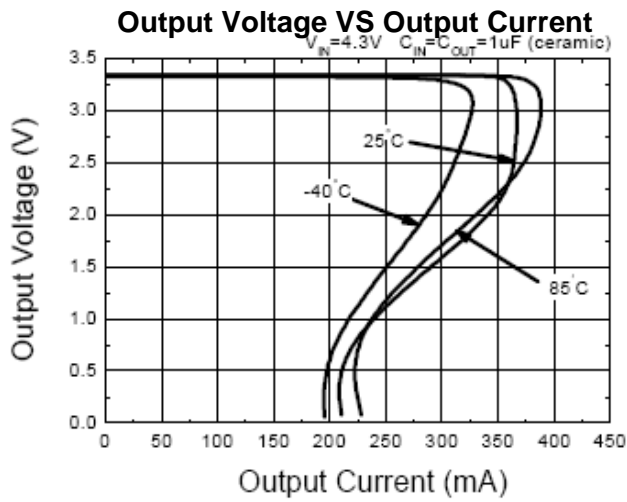

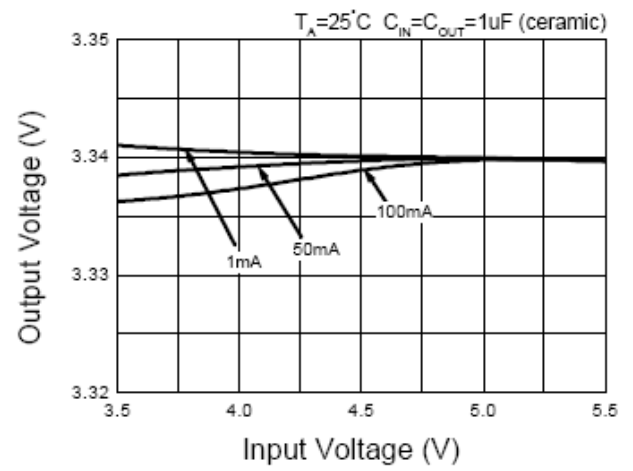
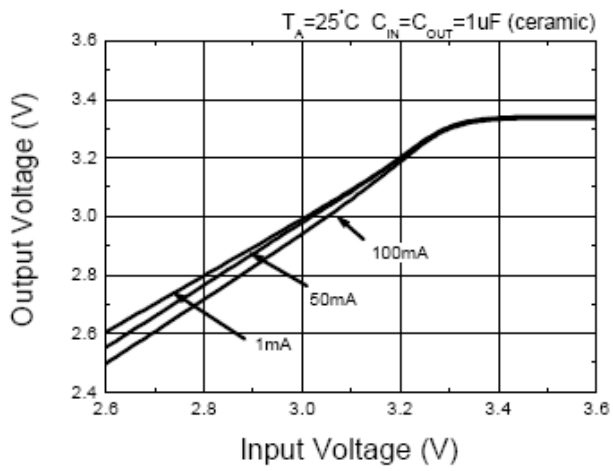
Output Voltage VS Input Voltage

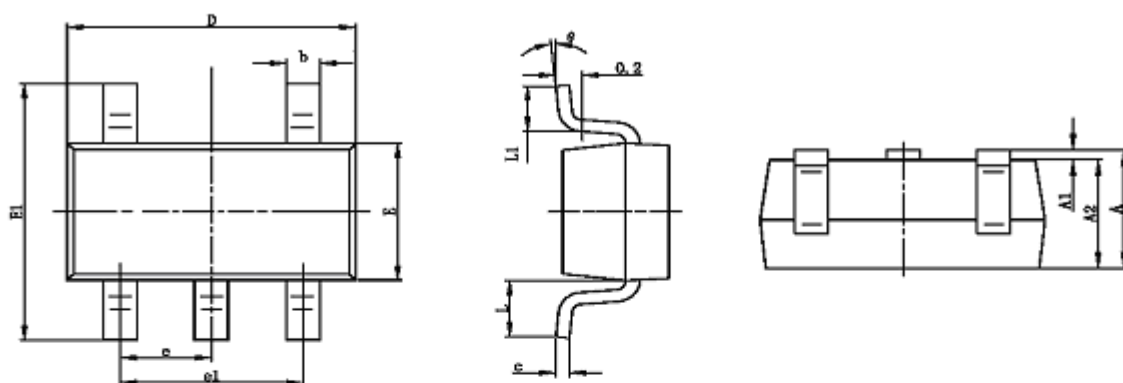
SOT-25 PACKAGE DIMENSIONS

Symbol	Dimensions In Millimeters		Dimensions In Inches	
	Min	Max	Min	Max
A	1.050	1.250	0.041	0.049
A1	0.000	0.100	0.000	0.004
A2	1.050	1.150	0.041	0.045
b	0.300	0.400	0.012	0.016
c	0.100	0.200	0.004	0.008
D	2.820	3.020	0.111	0.119
E	1.500	1.700	0.059	0.067
E1	2.650	2.950	0.104	0.116
e	0.950TYP		0.037TYP	
e1	1.800	2.000	0.071	0.079
L	0.700REF		0.028REF	
L1	0.300	0.600	0.012	0.024
θ	0°	8°	0°	8°