

Descriptions

- General purpose application
- Switching application

Features

- Large collector current
- Low collector saturation voltage
- Complementary pair with STN2907

Ordering Information

Type NO.	Marking	Package Code
STN2222	STN2222	TO-92

Outline Dimensions

unit : mm

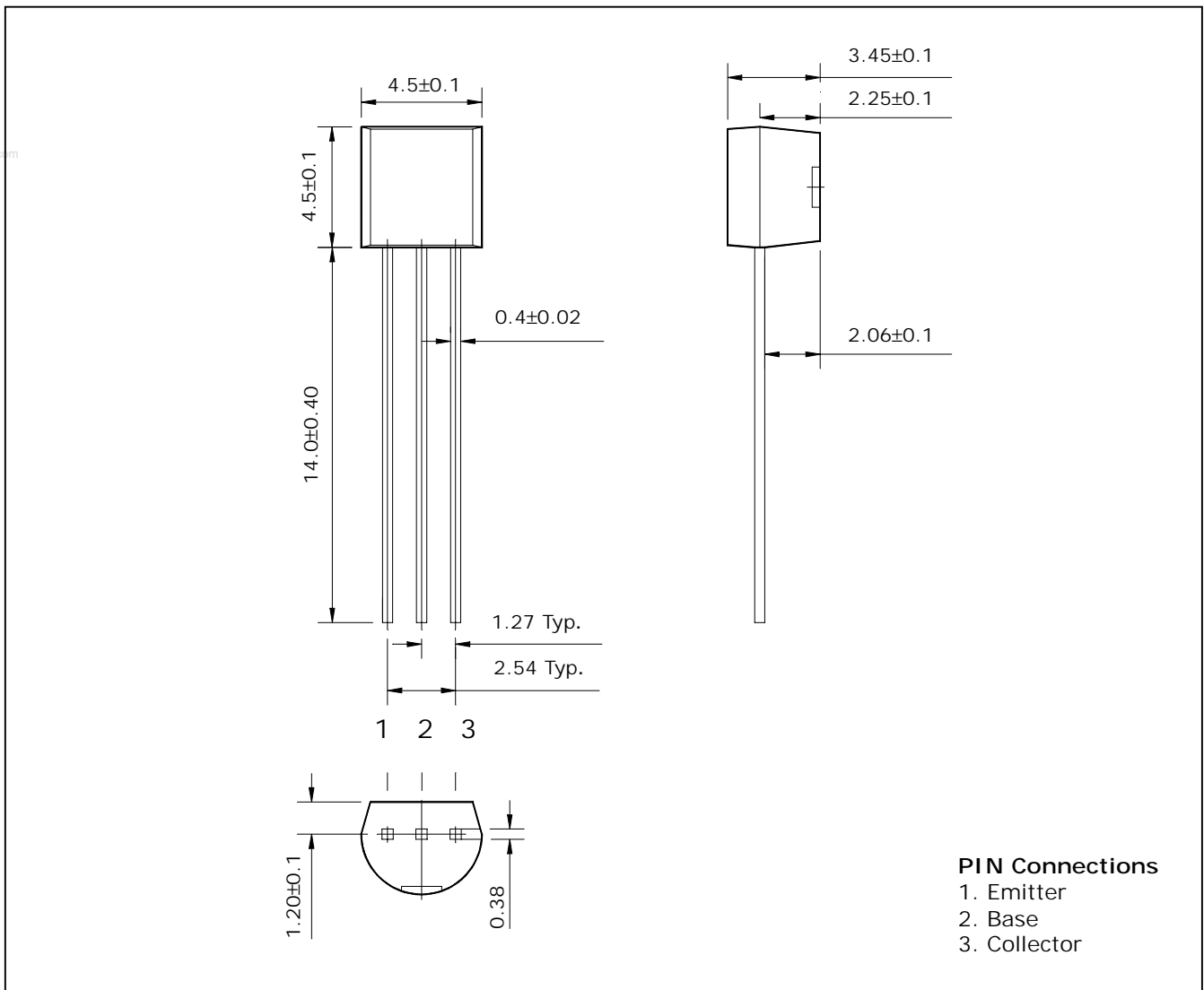

Absolute maximum ratings

Ta=25°C

Characteristic	Symbol	Ratings	Unit
Collector-Base voltage	V_{CBO}	60	V
Collector-Emitter voltage	V_{CEO}	30	V
Emitter-base voltage	V_{EBO}	5	V
Collector current	I_C	600	mA
Collector dissipation	P_C	625	mW
Junction temperature	T_J	150	°C
Storage temperature range	T_{stg}	-55 ~ 150	°C

Electrical Characteristics

Ta=25°C

Characteristic	Symbol	Test Condition	Min.	Typ.	Max.	Unit
Collector-Base breakdown voltage	BV_{CBO}	$I_C=10\mu A, I_E=0$	60	-	-	V
Collector-Emitter breakdown voltage	BV_{CEO}	$I_C=10mA, I_B=0$	30	-	-	V
Emitter-Base breakdown voltage	BV_{EBO}	$I_E=10\mu A, I_C=0$	5	-	-	V
Collector cut-off current	I_{CBO}	$V_{CB}=60V, I_E=0$	-	-	10	nA
DC current gain	h_{FE}	$V_{CE}=10V, I_C=10mA$	75	-	-	-
Collector-Emitter saturation voltage	$V_{CE(sat)}$	$I_C=150mA, I_B=15mA$	-	-	0.4	V
Transistor frequency	f_T	$V_{CE}=20V, I_C=20mA$	250	-	-	MHz
Collector output capacitance	C_{ob}	$V_{CB}=10V, I_E=0, f=1MHz$	-	6.0	-	pF

Electrical Characteristic Curves

Fig. 1 P_C - T_a

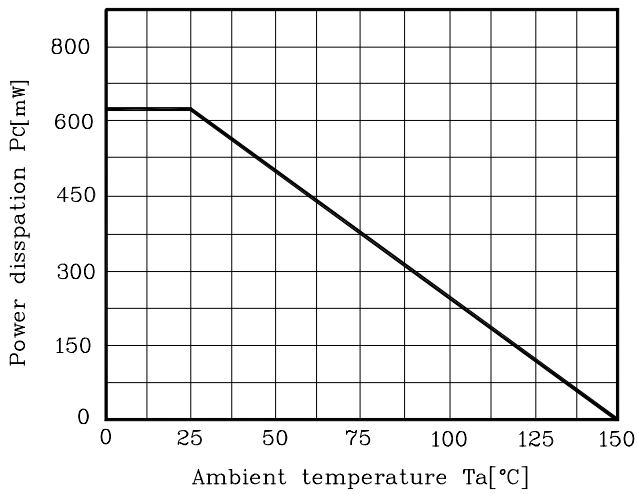

Fig. 2 I_C - V_{BE}

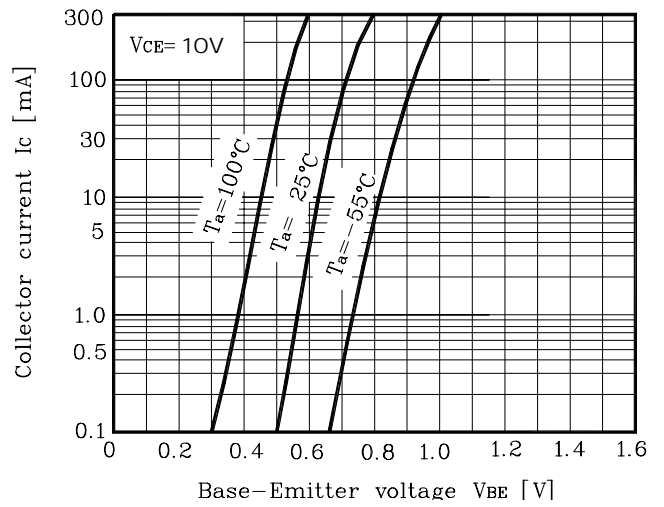

Fig. 3 I_C - V_{CE}

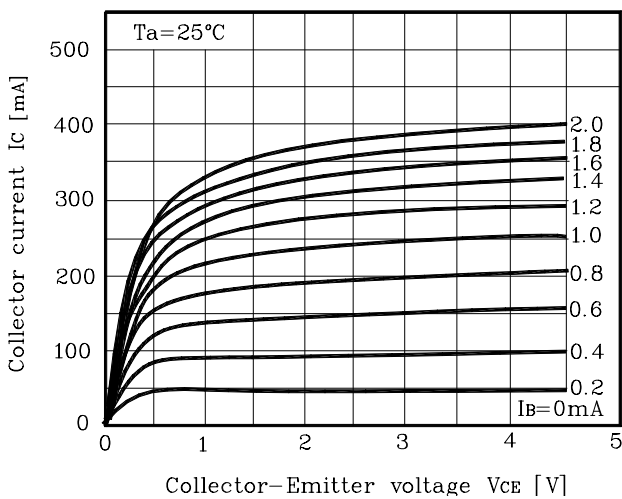

Fig. 4 $V_{CE(sat)}$ - I_C

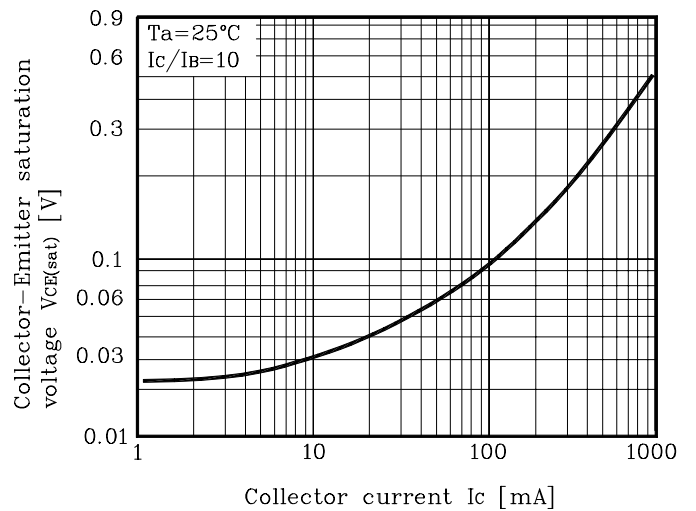

Fig. 5 h_{FE} - I_C

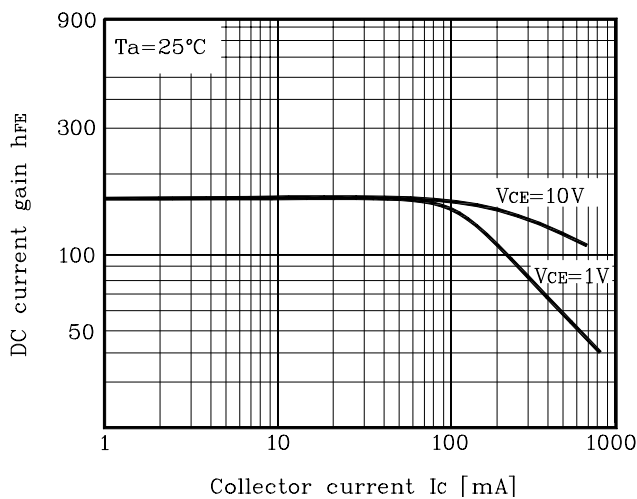

Fig. 6 h_{FE} - I_C

