



-40.0A

DESCRIPTION

STP6635GH is the P-Channel logic enhancement mode power field effect transistor which is produced using high cell density, DMOS trench technology. The STP413D has been designed specially to improve the overall efficiency of DC/DC converters using either synchronous or conventional switching PWM controllers. It has been optimized for low gate charge, low $R_{DS(ON)}$ and fast switching speed.

PIN CONFIGURATION (D-PAK)

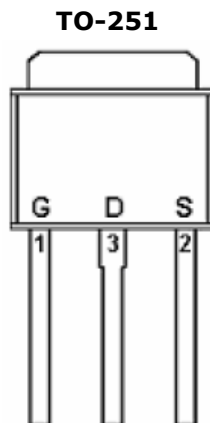
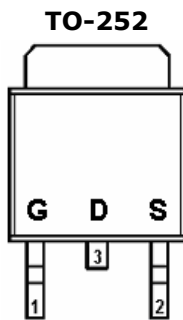

FEATURE

- -30V/-26.0A, $R_{DS(ON)} = 20m\Omega$
@ $V_{GS} = -10V$
- -30V/-16.0A, $R_{DS(ON)} = 36m\Omega$
@ $V_{GS} = -4.5V$
- Super high density cell design for extremely low $R_{DS(ON)}$
- Exceptional on-resistance and maximum DC current capability
- TO-252 package design

PART MARKING

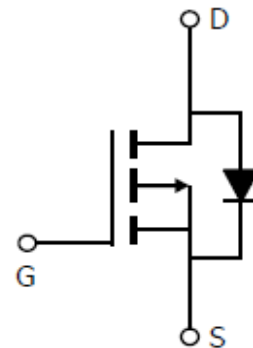
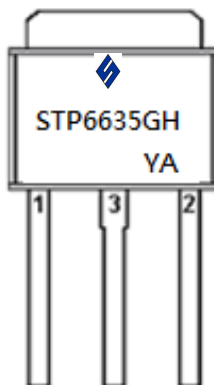

Y: Year Code A: Process Code



-40.0A

ABSOLUTE MAXIMUM RATINGS (Ta = 25°C Unless otherwise noted)

Parameter	Symbol	Typical	Unit
Drain-Source Voltage	VDSS	-30	V
Gate-Source Voltage	VGSS	±20	V
Continuous Drain Current (TJ=150°C)	ID	TA=25°C -40.0	A
		TA=70°C -25.0	
Pulsed Drain Current	IDM	-150	A
Continuous Source Current (Diode Conduction)	IS	-32	A
Power Dissipation	PD	44	W
Operation Junction Temperature	TJ	150	°C
Storage Temperature Range	TSTG	-55/150	°C
Thermal Resistance-Junction to Ambient	RθJA	60	°C/W



-40.0A

ELECTRICAL CHARACTERISTICS (Ta = 25°C Unless otherwise noted)

Parameter	Symbol	Condition	Min	Typ	Max	Unit
Static						
Drain-Source Breakdown Voltage	$V_{(BR)DSS}$	$V_{GS}=0V, I_D=-250\mu A$	-30			V
Gate Threshold Voltage	$V_{GS(th)}$	$V_{DS}=V_{GS}, I_D=-250\mu A$	-1.0		-3.0	V
Gate Leakage Current	I_{GSS}	$V_{DS}=0V, V_{GS}=\pm 20V$			± 100	nA
Zero Gate Voltage Drain Current	I_{DSS}	$V_{DS}=-30V, V_{GS}=0V$			-1	uA
		$V_{DS}=30V, V_{GS}=0V$ $T_J=55^\circ C$			-5	
On-State Drain Current	$I_{D(on)}$	$V_{DS} \geq -10V, V_{DS}=-5V$	-40			A
Drain-source On-Resistance	$R_{DS(on)}$	$V_{GS}=-10V, I_D=-26A$ $V_{GS}=-4.5V, I_D=-16A$			20 36	mΩ
Forward Transconductance	g_{fs}	$V_{DS}=-5V, I_D=-26A$		31		S
Diode Forward Voltage	V_{SD}	$I_S=-26.0A, V_{GS}=0V$			-1.3	V
Dynamic						
Total Gate Charge	Q_g	$V_{GS}=-4.5V, V_{DS}=-25V$ $I_D=-26A$		16.5		nC
Gate-Source Charge	Q_{gs}			3.8		
Gate-Drain Charge	Q_{gd}			12		
Input Capacitance	C_{iss}	$V_{DS} = -25V, V_{GS}=0V$ $f=1MHz$		1600		pF
Output Capacitance	C_{oss}			169		
Reverse Transfer Capacitance	C_{rss}			175		
Turn-On Time	$t_{d(on)}$ t_r	$V_{GS}=-10V, V_{DS}=-15V$ $R_L=1.6\Omega, R_{GEN}=3.3\Omega$ $R_D=0.58\Omega, I_D=-26A$		7.9		nS
Turn-Off Time	$t_{d(off)}$ t_f			65		
				24.8		
				91.2		

TYPICAL CHARACTERISTICS

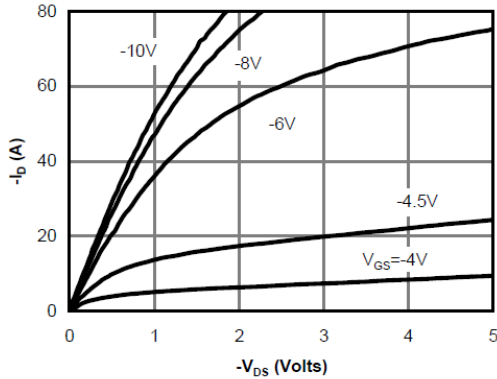

Figure 1: On-Region Characteristics

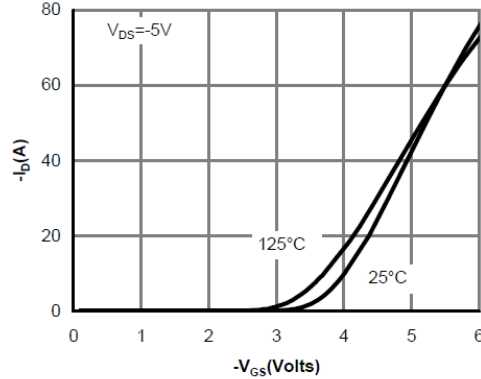

Figure 2: Transfer Characteristics

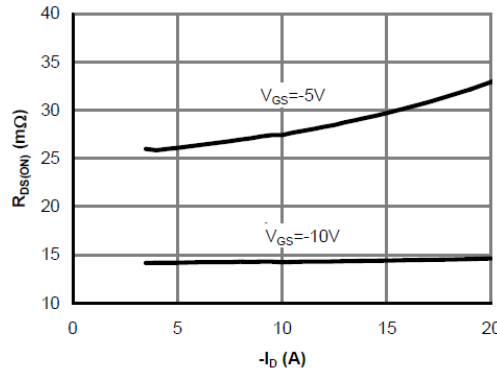

Figure 3: On-Resistance vs. Drain Current and Gate Voltage

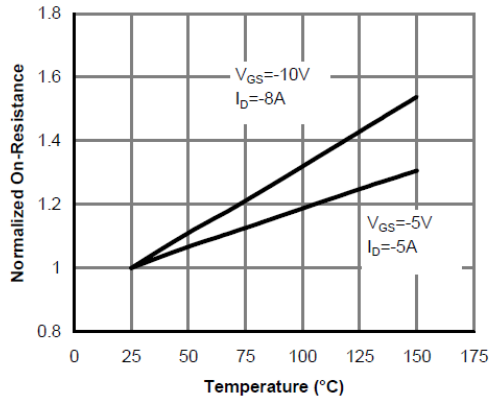

Figure 4: On-Resistance vs. Junction Temperature

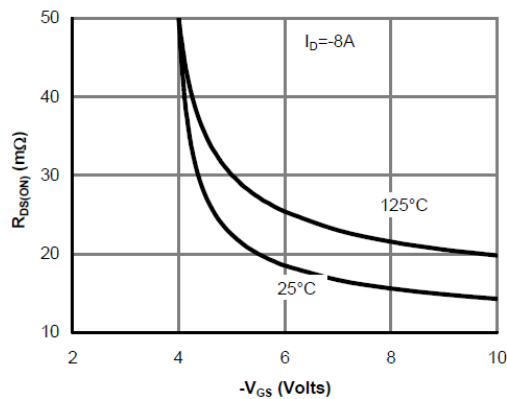

Figure 5: On-Resistance vs. Gate-Source Voltage

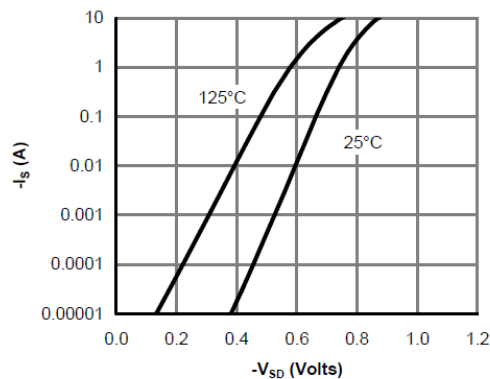

Figure 6: Body-Diode Characteristics

TYPICAL CHARACTERISTICS

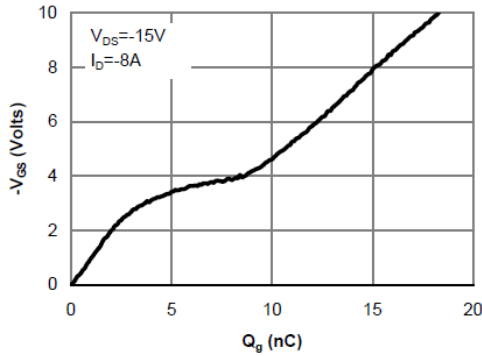

Figure 7: Gate-Charge Characteristics

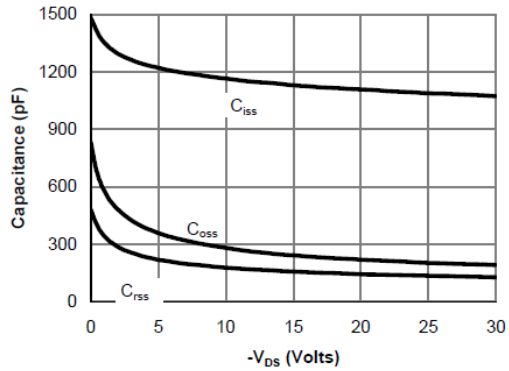

Figure 8: Capacitance Characteristics

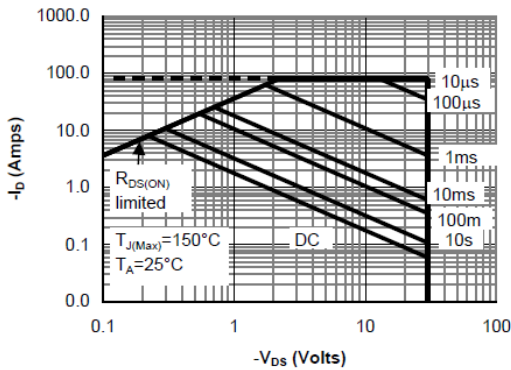

Figure 9: Maximum Forward Biased Safe Operating Area (Note F)

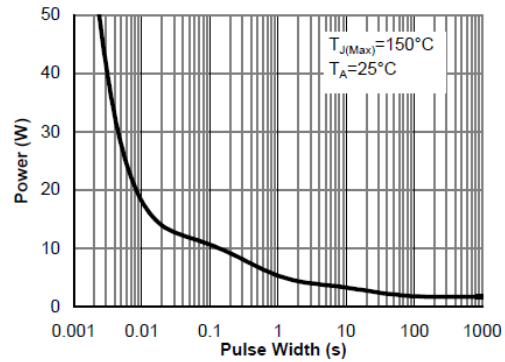

Figure 10: Single Pulse Power Rating Junction-to-Ambient (Note F)

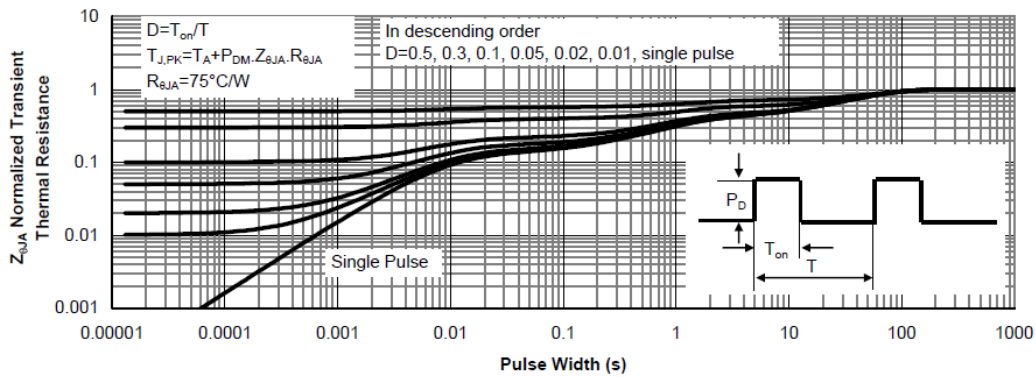
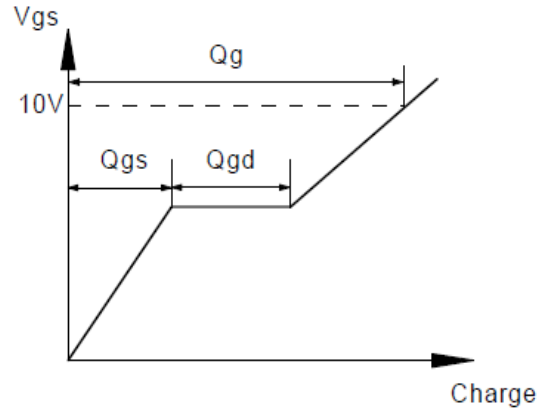
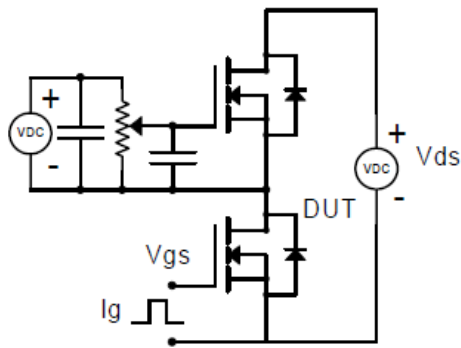
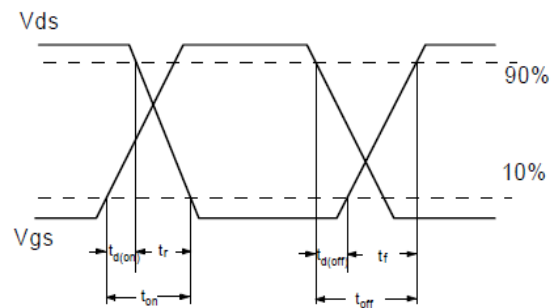
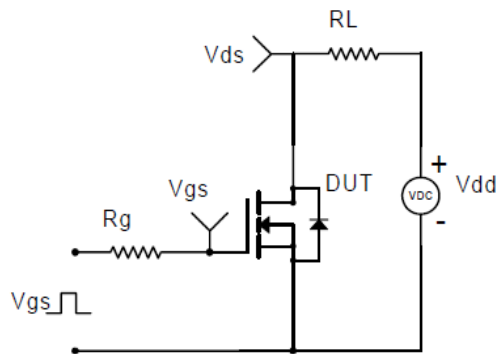

Figure 11: Normalized Maximum Transient Thermal Impedance (Note F)

GATE CHARGE TEST CIRCUIT & WAVEFORM



RESISTIVE SWITCHING TEST CIRCUIT & WAVEFORMS



UNCLAMPED INDUCTIVE SWITCHING (UIS) TEST CIRCUIT & WAVEFORMS

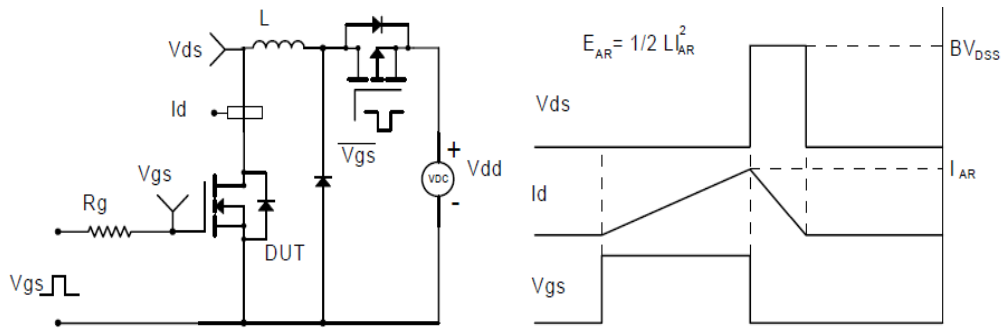

DIODE RECOVERY TEST CIRCUIT & WAVEFORMS

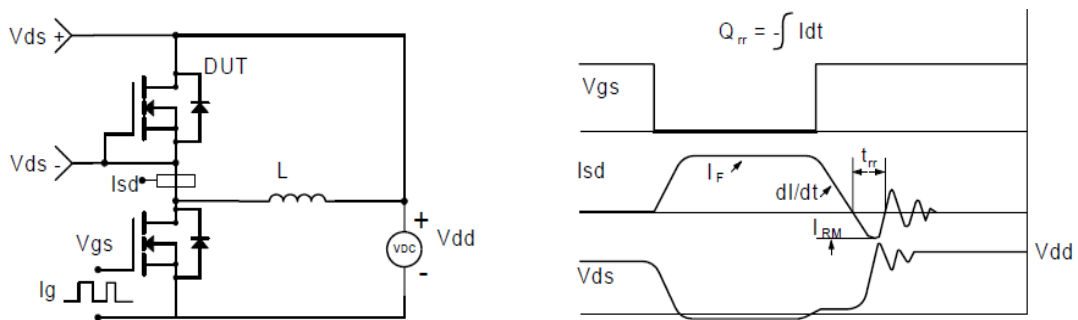

TO-252-2L PACKAGE OUTLINE SOP-8P

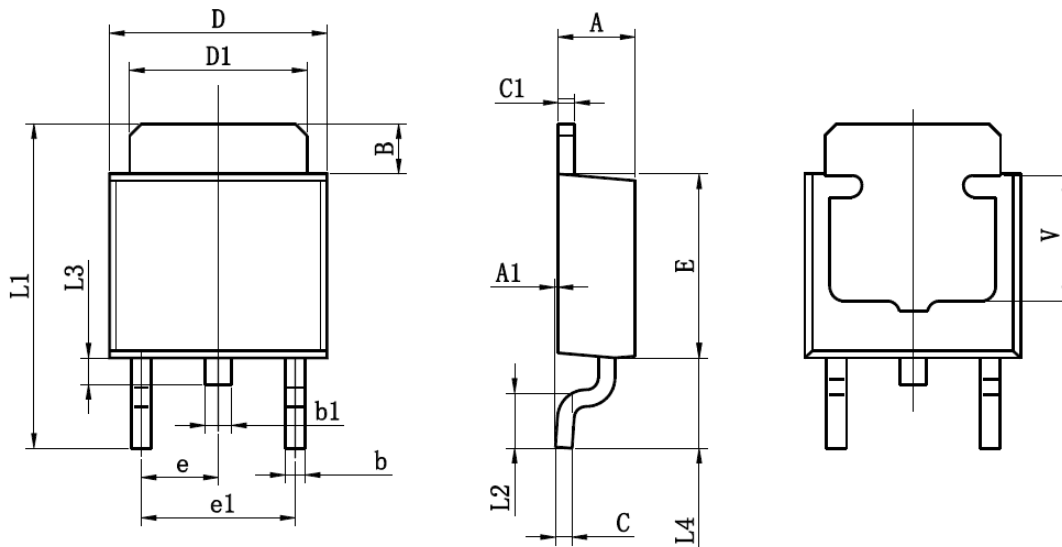

Symbol	Dimensions In Millimeters		Dimensions In Inches	
	Min	Max	Min	Max
A	2.200	2.400	0.087	0.094
A1	0.000	0.127	0.000	0.005
B	1.350	1.650	0.053	0.065
b	0.500	0.700	0.020	0.028
b1	0.700	0.900	0.028	0.035
c	0.430	0.580	0.017	0.023
c1	0.430	0.580	0.017	0.023
D	6.350	6.650	0.250	0.262
D1	5.200	5.400	0.205	0.213
E	5.400	5.700	0.213	0.224
e	2.300TYP		0.091TYP	
e1	4.500	4.700	0.177	0.185
L1	9.500	9.900	0.374	0.390
L2	1.400	1.780	0.055	0.070
L3	0.650	0.950	0.026	0.037
L4	2.550	2.900	0.100	0.114
V	3.80REF		0.150REF	