

4 x 50 W MOSFET quad bridge power amplifier

Datasheet - production data

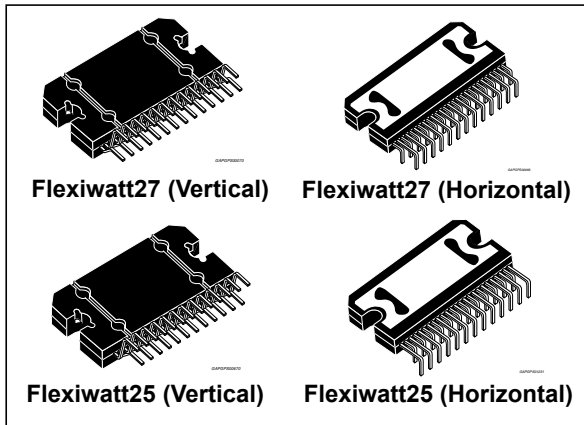

- Internally fixed gain (26 dB)
- Protections:
 - Output short circuit to GND, to Vs, across the load
 - Very inductive loads
 - Overrating chip temperature with soft thermal limiter
 - Output DC offset detection
 - Load dump
 - Fortuitous open GND
 - Reversed battery
 - ESD
 - Capable to operate down to 6 V (e.g. “Startstop”)

Features

- Multipower BCD technology
- High output power capability:
 - 4 x 50 W/4 Ω Max.
 - 4 x 28 W/4 Ω @ 14.4 V, 1 kHz, 10 %
 - 4 x 72 W/2 Ω Max.
- MOSFET output power stage
- 2 Ω driving capability
- Hi-Fi class distortion
- Low output noise
- High immunity to RF noise injection
- Standby function
- Mute function
- Automute at min. supply voltage detection
- Low external component count

Description

The STPA001 is a breakthrough MOSFET technology class AB audio power amplifier designed for high power car radio. The fully complementary P-Channel/N-Channel output structure allows a rail to rail output voltage swing which, combined with high output current and minimized saturation losses sets new power references in the car-radio field, with unparalleled distortion performances.

The STPA001 can operate down to 6 V and this makes the IC compliant to the most recent OEM specifications for low voltage operation (so called 'start-stop' battery profile during engine stop), helping car manufacturers to reduce the overall emissions and thus contributing to environment protection.

Table 1. Device summary

Order code	Package	Packing
STPA001	Flexiwatt25 (Vertical)	Tube
STPA001H	Flexiwatt25 (Horizontal)	Tube
STPA001A	Flexiwatt27 (Vertical)	Tube
STPA001AH	Flexiwatt27 (Horizontal)	Tube

Contents

1	Overview	5
1.1	Block diagram and application circuit	5
2	Pin description	7
2.1	Pin connection	7
2.2	Pin functions	8
3	Electrical specifications	9
3.1	Absolute maximum ratings	9
3.2	Thermal data	9
3.3	Electrical characteristics	10
3.4	Electrical characteristics curves	12
4	General information	15
4.1	Operation	15
4.2	Battery variations	15
4.2.1	Low voltage operation	15
4.2.2	Cranks	16
4.2.3	Advanced battery management (hybrid vehicles)	17
4.3	Protections	18
4.3.1	Short circuits and open circuit operation	18
4.3.2	Over-voltage and load dump protection	18
4.3.3	Thermal protection	18
4.4	Warnings	19
4.4.1	DC offset detection (OD pin)	19
4.4.2	Clipping detection and diagnostics (CD-DIAG pin)	19
4.5	Heat sink definition	20
5	Package information	21
6	Revision history	25

List of tables

Table 1.	Device summary	1
Table 2.	Pin functions	8
Table 3.	Absolute maximum ratings	9
Table 4.	Thermal data	9
Table 5.	Electrical characteristics	10
Table 6.	Document revision history.	25

List of figures

Figure 1.	Block diagram	5
Figure 2.	Application circuit (STPA001)	6
Figure 3.	Application circuit (STPA001A & STPA001H)	6
Figure 4.	Pin connection (top view)	7
Figure 5.	Quiescent current vs. supply voltage	12
Figure 6.	Output power vs. supply voltage (4 Ω)	12
Figure 7.	Output power vs. supply voltage (2 Ω)	12
Figure 8.	Distortion vs. output power (4 Ω)	12
Figure 9.	Distortion vs. frequency (4 Ω)	12
Figure 10.	Distortion vs. output power (4 Ω , $V_s = 6$ V)	12
Figure 11.	Distortion vs. output power (2 Ω)	13
Figure 12.	Distortion vs. frequency (2 Ω)	13
Figure 13.	Distortion vs. output power (2 Ω , $V_s = 6$ V)	13
Figure 14.	Supply voltage rejection vs. frequency	13
Figure 15.	Crosstalk vs. frequency	13
Figure 16.	Total power dissipation & efficiency vs. P_o (4 Ω , Sine)	13
Figure 17.	Power dissipation vs. average output power (4 Ω , audio program simulation)	14
Figure 18.	Power dissipation vs. average output power (2 Ω , audio program simulation)	14
Figure 19.	ITU R-ARM frequency response, weighting filter for transient pop	14
Figure 20.	SVR charge diagram	15
Figure 21.	Battery cranking curve example 1	16
Figure 22.	Battery cranking curve example 2	16
Figure 23.	Upwards fast battery transitions diagram	17
Figure 24.	Load dump protection diagram	18
Figure 25.	Thermal protection diagram	18
Figure 26.	Audio section waveforms	19
Figure 27.	Flexiwatt27 (vertical) mechanical data and package dimensions	21
Figure 28.	Flexiwatt27 (horizontal) mechanical data and package dimensions	22
Figure 29.	Flexiwatt25 vertical mechanical data and package dimensions	23
Figure 30.	Flexiwatt25 (horizontal) mechanical data and package dimensions	24

1 Overview

The STPA001 is a complementary quad audio power amplifier. It is available in three different packages, Flexiwatt25 (vertical), Flexiwatt25 (horizontal) and Flexiwatt27. It embeds four independent amplifiers working in class AB, a standby and a mute pin, a clipping detector and diagnostics output and, only for the Flexiwatt27 package, an offset detector pin. The amplifier is fully operational down to a battery voltage of 6 V, without producing pop noise and continuing to play during battery transitions.

The STPA001 can drive 2 Ω loads and has a very high immunity to disturbs without need of external components or compensation. It is protected against any kind of short or open circuit, over-voltage and over-temperature.

1.1 Block diagram and application circuit

Figure 1. Block diagram

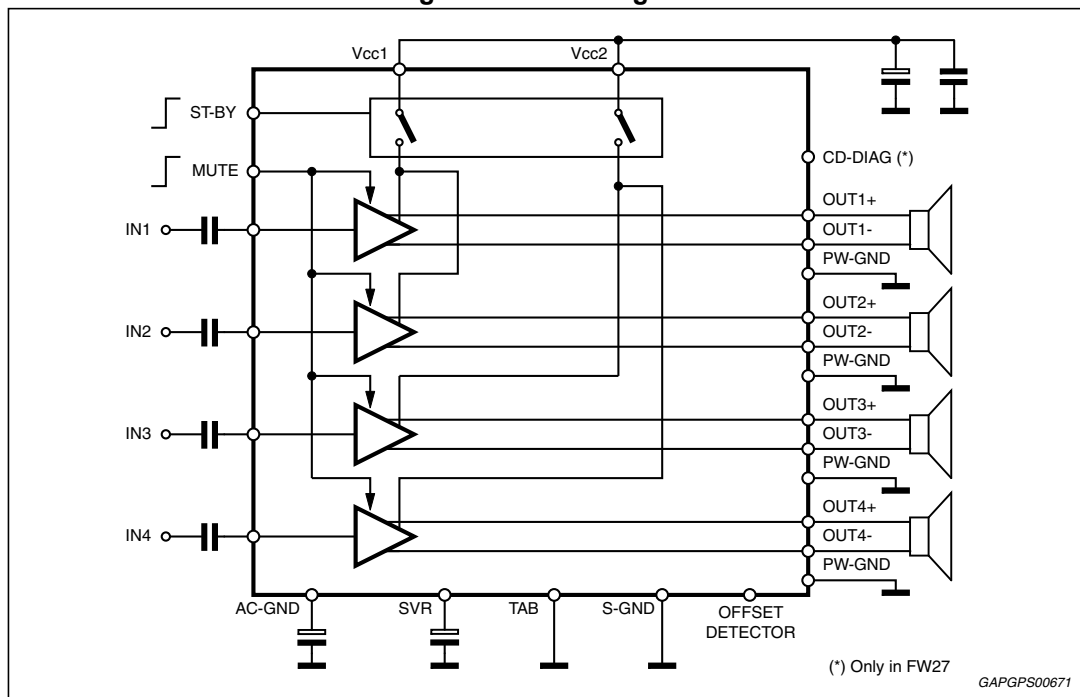
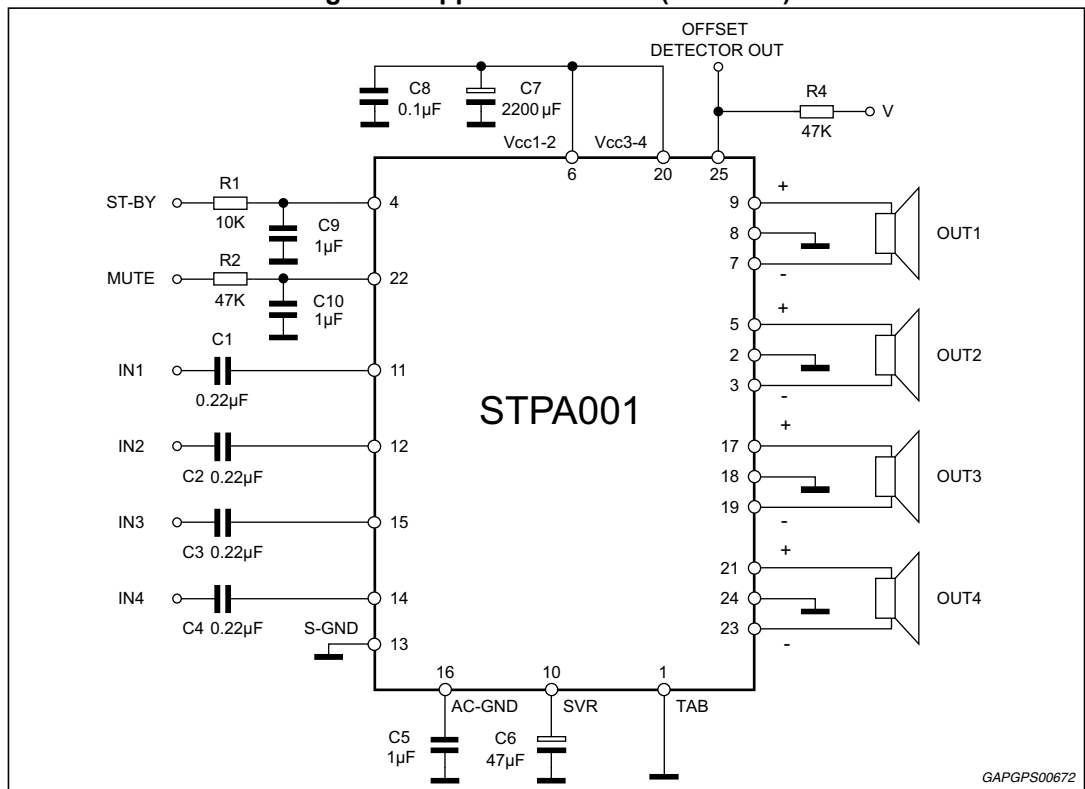
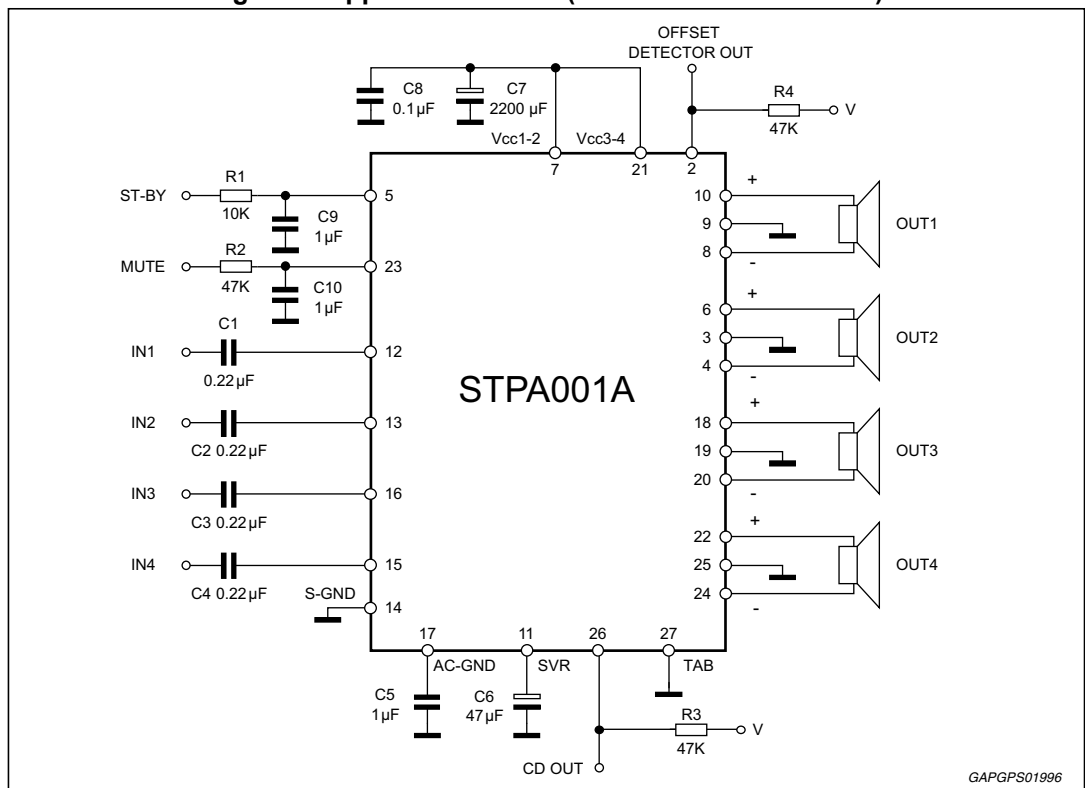

Figure 2. Application circuit (STPA001)



GAPGPS00672

Figure 3. Application circuit (STPA001A & STPA001H)



GAPGPS01996

2 Pin description

2.1 Pin connection

Figure 4. Pin connection (top view)

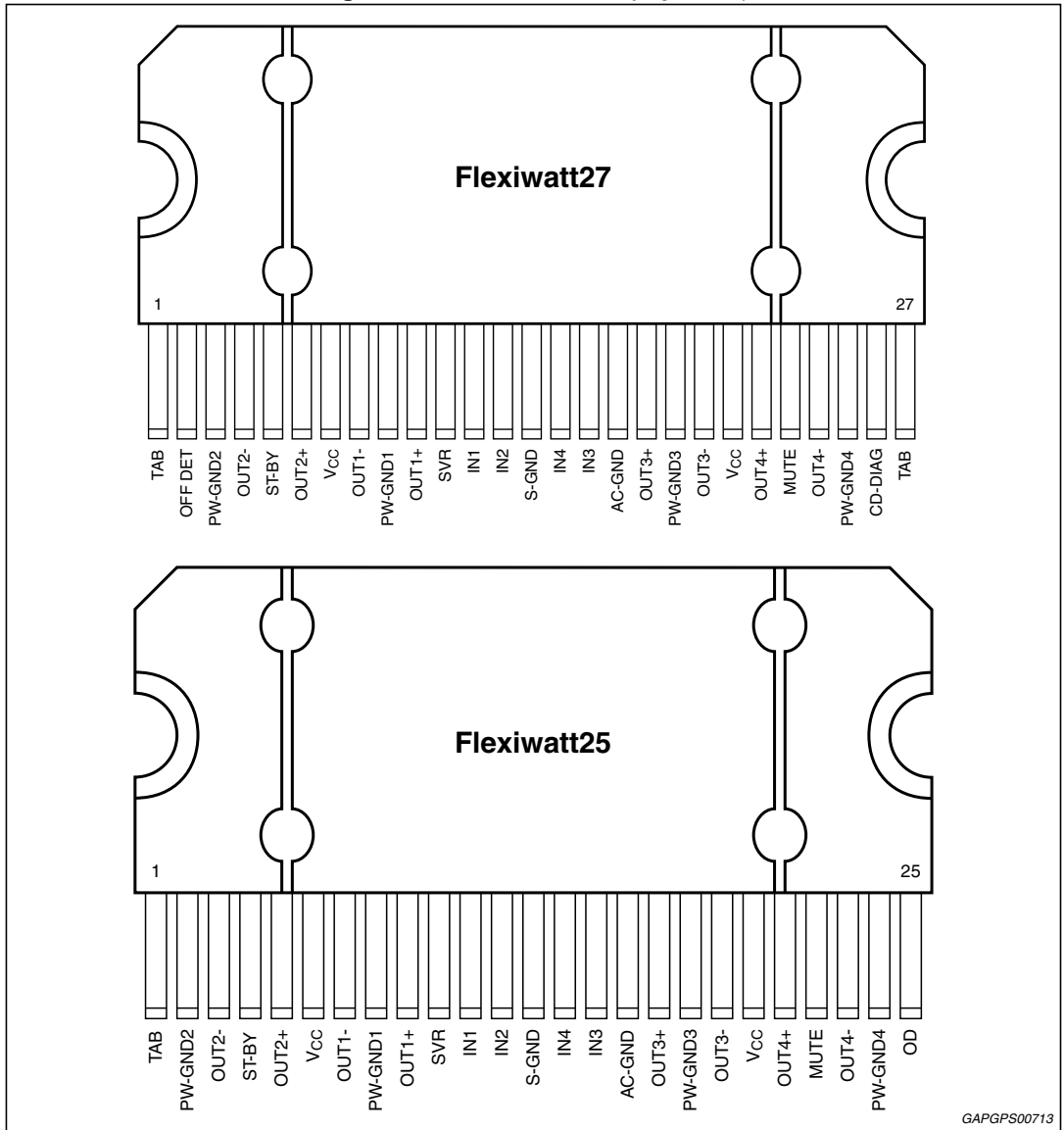

GAPGPS00713

2.2 Pin functions

Table 2. Pin functions

Pin number FW27	Pin number FW25	Pin name	Description
1	1	TAB	-
2	25	OD	Offset detector output
3	2	PW-GND2	Channel 2, output power ground
4	3	OUT2-	Channel 2, negative output
5	4	ST-BY	Stand-by
6	5	OUT2+	Channel 2, positive output
7	6	VCC	Supply voltage
8	7	OUT1-	Channel 1, negative output
9	8	PW-GND1	Channel 1, output power ground
10	9	OUT1+	Channel 1, positive output
11	10	SVR	Supply voltage rejection pin
12	11	IN1	Channel 1, input
13	12	IN2	Channel 2, input
14	13	S-GND	Signal ground
15	14	IN4	Channel 4, input
16	15	IN3	Channel 3, input
17	16	AC-GND	AC ground
18	17	OUT3+	Channel 3, positive output
19	18	PW-GND3	Channel 3, output power ground
20	19	OUT3-	Channel 3, negative output
21	20	VCC	Supply voltage
22	21	OUT4+	Channel 4, positive output
23	22	MUTE	Mute pin
24	23	OUT4-	Channel 4, negative output
25	24	PW-GND4	Channel 4, output power ground
26	n.a	CD-DIAG	Clipping detector and diagnostics output
27	n.a	TAB	-

3 Electrical specifications

3.1 Absolute maximum ratings

Table 3. Absolute maximum ratings

Symbol	Parameter	Value	Unit
V_S	Operating supply voltage	18	V
$V_{S(DC)}$	DC supply voltage	28	V
$V_{S(pk)}$	Peak supply voltage (for $t = 50$ ms)	50	V
I_O	Output peak current Non repetitive ($t = 100$ μ s)	10	A
	Repetitive (duty cycle 10 % at $f = 10$ Hz)	9	A
P_{tot}	Power dissipation $T_{case} = 70$ °C	85	W
T_j	Junction temperature	150	°C
T_{stg}	Storage temperature	-55 to 150	°C
GND_{max}	Ground pin voltage	-0.3 to 0.3	V
$V_{in max}$	Input pin max voltage	-0.3 to 8	V
$V_{SB max}$	ST-BY pin max voltage	-0.3 to $V_{S(pk)}$	V
$V_{mute max}$	Mute pin max voltage	-0.3 to 6	V

3.2 Thermal data

Table 4. Thermal data

Symbol	Parameter	Value	Unit
$R_{th j-case}$	Thermal resistance junction-to-case	Max 1	°C/W

3.3 Electrical characteristics

Refer to the test and application diagram, $V_S = 14.4\text{ V}$; $R_L = 4\ \Omega$; $R_g = 600\ \Omega$; $f = 1\text{ kHz}$;
 $T_{\text{amb}} = 25\text{ }^\circ\text{C}$; unless otherwise specified.

Table 5. Electrical characteristics

Symbol	Parameter	Test condition	Min.	Typ.	Max.	Unit
General characteristics						
V_S	Supply voltage range	-	6	-	18	V
I_{q1}	Quiescent current	$R_L = \infty$	100	200	300	mA
V_{OS}	Output offset voltage	Play mode / Mute mode	-90	-	+90	mV
dV_{OS}	During mute ON/OFF output offset voltage	ITU R-ARM weighted	-10	-	+10	mV
	During standby ON/OFF output offset voltage		-15	-	+15	mV
R_i	Input impedance	-	40	55	70	k Ω
I_{SB}	Standby current consumption	$V_{\text{St-by}} = 1.2\text{ V}$	-	-	20	μA
		$V_{\text{St-by}} = 0$	-	-	10	μA
Audio performances						
P_o	Output power	THD = 10 %	26	28	-	W
		THD = 1 %	20	22	-	W
		THD = 10 %, 2 Ω	43	48	-	W
		THD = 1 %, 2 Ω	34	38	-	W
$P_{o\text{ max.}}$	Max. output power	Square wave input (2 Vrms)				
		$R_L = 4\ \Omega$	41	45	-	W
		$R_L = 2\ \Omega$	68	75	-	W
		$V_S = 15.2\text{ V}$; $R_L = 4\ \Omega$	46	50	-	W
THD	Distortion	$P_o = 4\text{ W}$	-	0.007	0.05	%
G_v	Voltage gain	-	25	26	27	dB
dG_v	Channel gain unbalance	-	-1	-	+1	dB
e_{No}	Output Noise	"A" Weighted	-	35	-	μV
		Bw = 20 Hz to 20 kHz	-	50	100	μV
SVR	Supply voltage rejection	$f = 100\text{ Hz}$; $V_r = 1\text{ Vrms}$	50	70	-	dB
f_{ch}	High cut-off frequency	$P_o = 0.5\text{ W}$	100	300	-	kHz
C_T	Cross talk	$f = 1\text{ kHz}$ $P_o = 4\text{ W}$	60	75	-	dB
		$f = 10\text{ kHz}$ $P_o = 4\text{ W}$	-	60	-	dB
A_M	Mute attenuation	$P_{\text{Oref}} = 4\text{ W}$	80	90	-	dB
Control pin characteristics						
I_{pin5}	Standby pin current	$V_{\text{St-by}} = 1.2\text{ V to } 2.6\text{ V}$	-	-	1	μA
$V_{\text{SB out}}$	Standby out threshold voltage	(Amp: ON)	2.6	-	-	V

Table 5. Electrical characteristics (continued)

Symbol	Parameter	Test condition	Min.	Typ.	Max.	Unit
$V_{SB\ in}$	Standby in threshold voltage	(Amp: OFF)	-	-	1.2	V
$V_{M\ out}$	Mute out threshold voltage	(Amp: Play)	2.6	-	-	V
$V_{M\ in}$	Mute in threshold voltage	(Amp: Mute)	-	-	1.2	V
$V_{AM\ in}$	V_S automute threshold	(Amp: Mute) Att \geq 80 dB; $P_{Oref} = 4\ W$	4.5	5	5.5	V
		(Amp: Play) Att $<$ 0.1 dB; $P_O = 0.5\ W$	-	-	6	V
I_{pin23}	Muting pin current	$V_{MUTE} = 1.2\ V$ (Sourced current)	5	8	12	μA
Offset detector						
V_{OFF}	Detected differential output offset	$V_{St-by} = 5\ V$	± 1	± 2	± 3	V
V_{OFF_SAT}	Off detector saturation voltage	$V_o > \pm 3\ V$, $I_{off\ Det} = 1\ mA$ $0\ V < V_{off\ Det} < 18\ V$	-	0.1	0.2	V
V_{OFF_LK}	Off detector leakage current	$V_o < \pm 1\ V$	-	0	15	μA
Clipping detector						
CD_{LK}	Clip detector high leakage current	Cd off	-	0	1	μA
CD_{SAT}	Clip detector saturation voltage	DC On; $I_{CD} = 1\ mA$	-	0.1	0.2	V
CD_{THD}	Clip detector THD level	$V_{CC} > 6.5\ V$	-	1	-	%

3.4 Electrical characteristics curves

Figure 5. Quiescent current vs. supply voltage

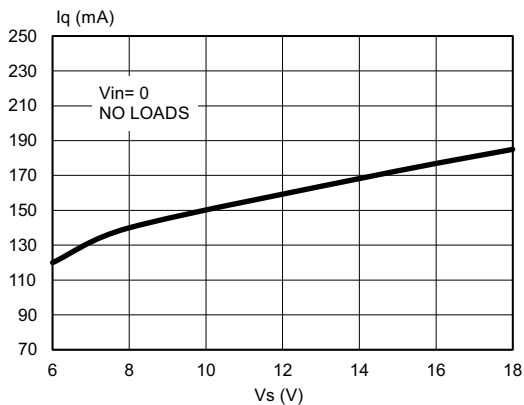

GAPGPS01997

Figure 6. Output power vs. supply voltage (4 Ω)

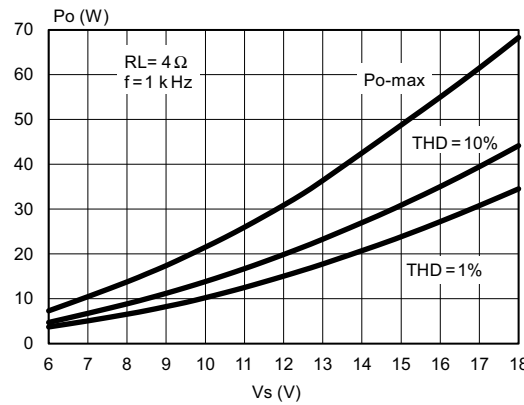

GAPGPS01998

Figure 7. Output power vs. supply voltage (2 Ω)

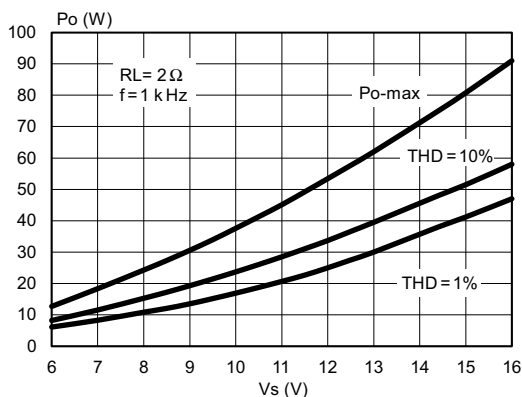

GAPGPS01999

Figure 8. Distortion vs. output power (4 Ω)

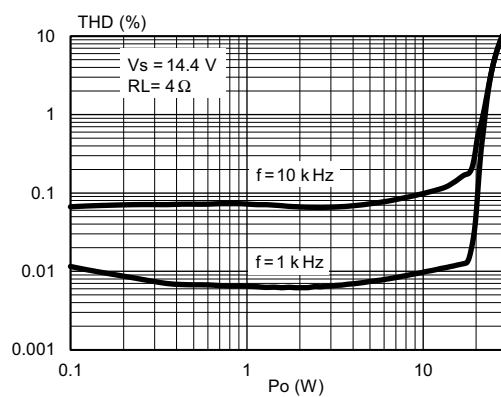

GAPGPS02000

Figure 9. Distortion vs. frequency (4 Ω)

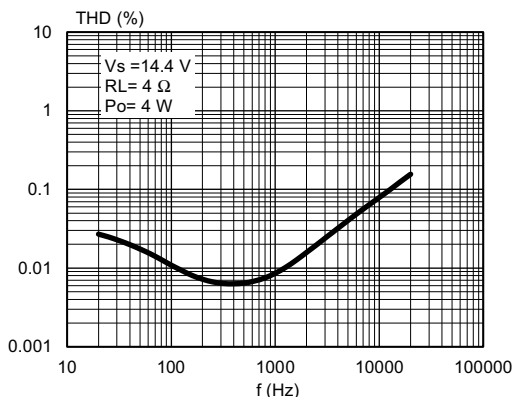

GAPGPS02001

Figure 10. Distortion vs. output power (4 Ω, Vs = 6 V)

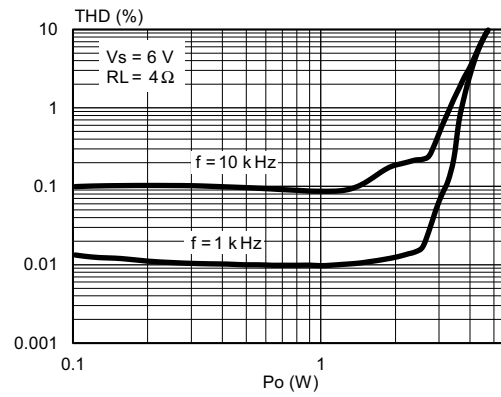

GAPGPS02002

Figure 11. Distortion vs. output power (2 Ω)

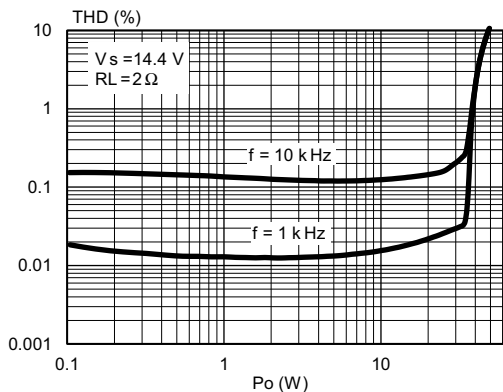

GAPGPS02003

Figure 12. Distortion vs. frequency (2 Ω)

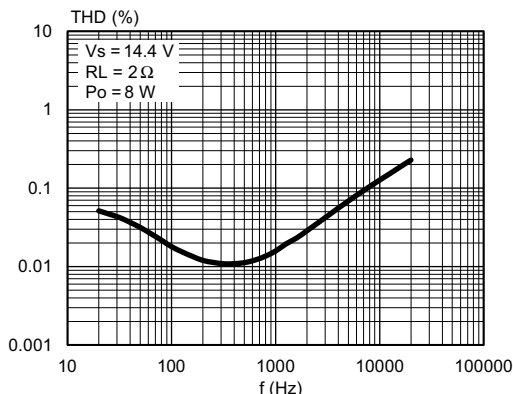

GAPGPS02004

Figure 13. Distortion vs. output power (2 Ω, Vs = 6 V)

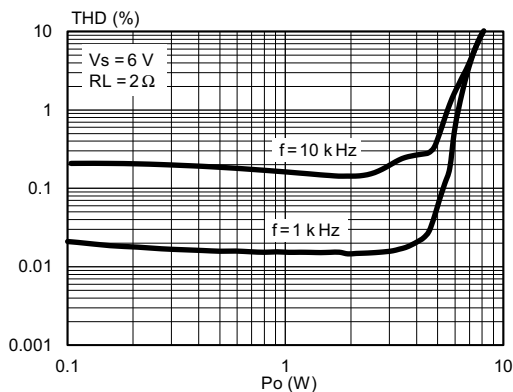

GAPGPS02005

Figure 14. Supply voltage rejection vs. frequency

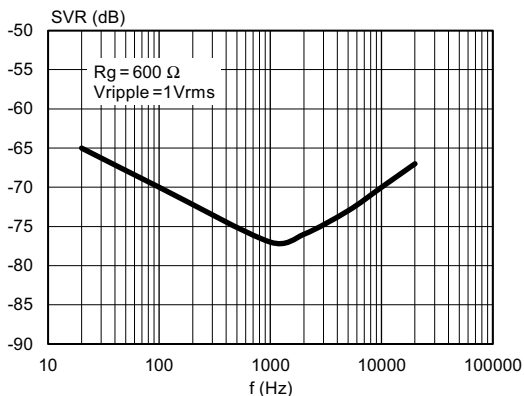

GAPGPS02006

Figure 15. Crosstalk vs. frequency

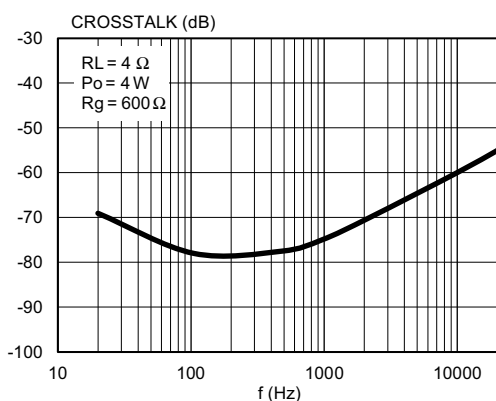

GAPGPS02007

Figure 16. Total power dissipation & efficiency vs. Po (4 Ω, Sine)

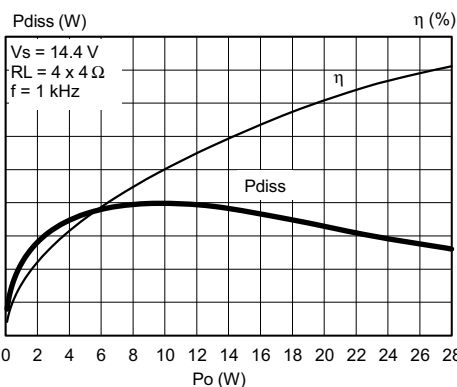

GAPGPS02008

Figure 17. Power dissipation vs. average output power (4 Ω, audio program simulation)

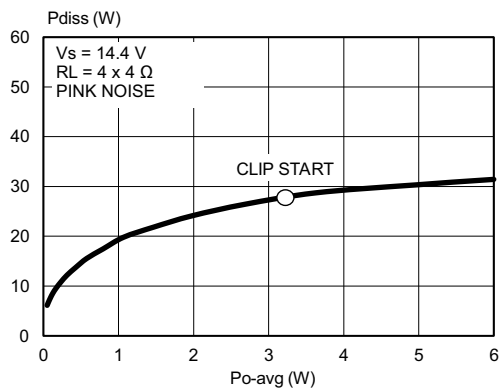

GAPGPS02009

Figure 18. Power dissipation vs. average output power (2 Ω, audio program simulation)

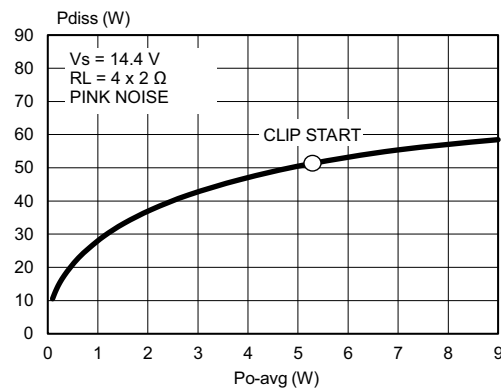

GAPGPS02010

Figure 19. ITU R-ARM frequency response, weighting filter for transient pop

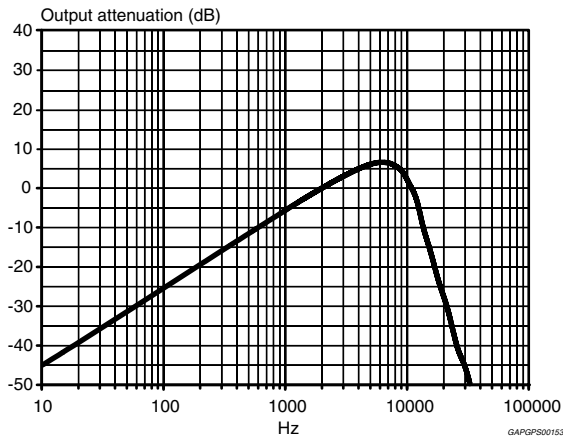

GAPGPS00153

4 General information

4.1 Operation

The STPA001's inputs are ground-compatible. If the standard value for the input capacitors (0.22 μF) is adopted, the low frequency cut-off will amount to 16 Hz. The input capacitors should be 1/4 of the capacitor connected to AC-GND pin for optimum pop performances (see [Figure 2: Application circuit \(STPA001\)](#)).

Standby and mute pins are both CMOS compatible.

RC cells at both mute and stand-by pins have always to be used in order to smooth the transitions for preventing any audible transient noise.

In case muting and stand-by functions are not used, they could steadily be connected to V_S , but a 470 k Ω resistance should be present between the power supply and the pins.

The capacitance on SVR sets the start-up and shut-down times and helps to have pop-noise free transitions. Its minimum recommended value is 10 μF . However, to have a fast start-up time, the internal resistor on SVR pin, used to set the time constant, is reduced from 50 k Ω to 3 k Ω till voltage on SVR reaches $V_{CC}/4 - 2V_{BE}$ and then released. In this way the capacitor on SVR is charged very quickly to $V_{CC}/4$, as shown in the following figure. The time constant to be assigned to the standby pin in order to obtain a virtually pop-free transition has to be slower than 2.5 V/ms.

Figure 20. SVR charge diagram

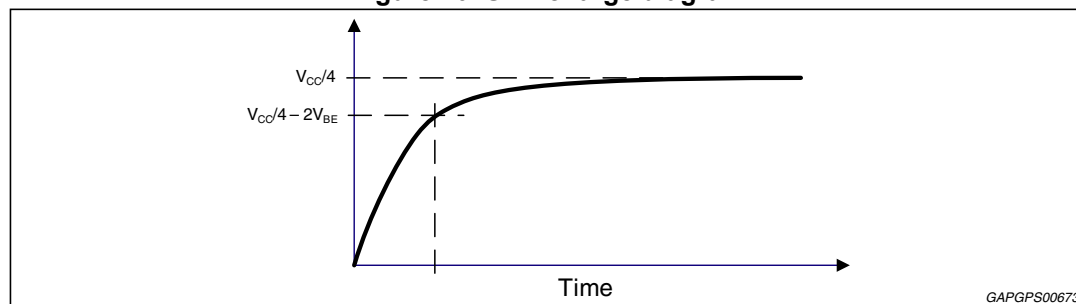

SVR pin accomplishes multiple functions:

- it is used as a reference voltage for input pins ($V_{CC}/4$)
- the capacitor connected to SVR helps the supply voltage ripple rejection
- it is used as a reference to generate the half supply voltage for the output

When the amplifier goes in standby mode or goes out from this condition, it is suggested to put the amplifier in mute to ensure the absence of audible noise. Then the stand-by pin can be set to the appropriate value (ground or $> 2.6\text{ V}$) and the capacitance on SVR pin is discharged or charged consequently.

4.2 Battery variations

4.2.1 Low voltage operation

The most recent OEM specifications are require automatic stop of car engine at traffic lights, in order to reduce emissions of polluting substances. The STPA001, thanks to its innovating

design, allows a continuous operation when battery falls down. At 6 V it is still fully operational, only the maximum output power is reduced accordingly to the available voltage supply.

If the battery voltage drops below the minimum operating voltage of 6V the amplifier is fast muted, the capacitor on SVR is discharged and the amplifier restarts when the battery voltage returns to the correct voltage.

4.2.2 Cranks

STPA001 can sustain worst case cranks from 16 V to 6 V, continuing to play and without producing any pop noise.

Examples of battery cranking curves are shown below, indicating the shape and duration of allowed battery transitions.

Figure 21. Battery cranking curve example 1

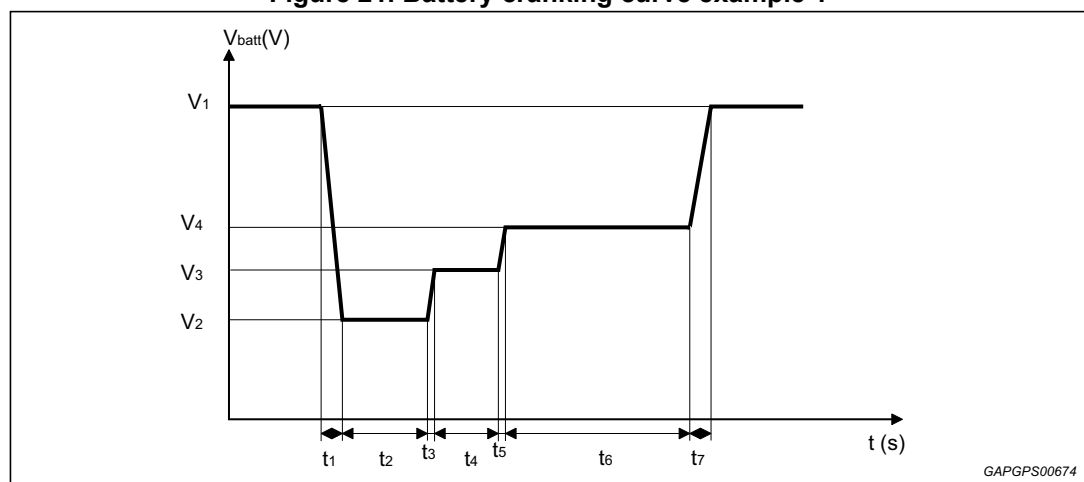

$V1 = 16\text{ V}; V2 = 6\text{ V}; V3 = 7\text{ V}; V4 = 8\text{ V}$

$t1 = 2\text{ ms}; t2 = 50\text{ ms}; t3 = 5\text{ ms}; t4 = 300\text{ ms}; t5 = 10\text{ ms}; t6 = 1\text{ s}; t7 = 2\text{ ms}$

Figure 22. Battery cranking curve example 2

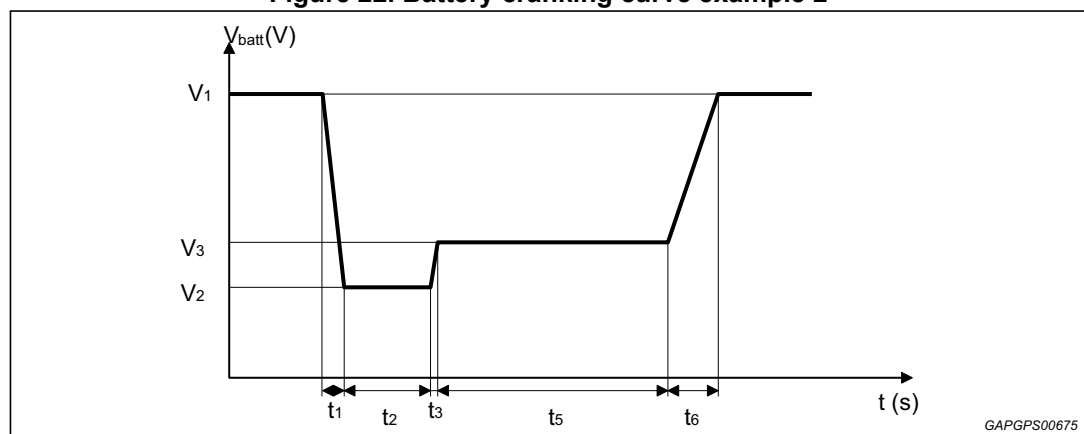

$V1 = 16\text{ V}; V2 = 6\text{ V}; V3 = 7\text{ V}$

$t1 = 2\text{ ms}; t2 = 5\text{ ms}; t3 = 15\text{ ms}; t5 = 1\text{ s}; t6 = 50\text{ ms}$

4.2.3 Advanced battery management (hybrid vehicles)

In addition to compatibility with low V_{batt} , the STPA001 is able to sustain upwards fast battery transitions without causing unwanted audible effects, like pop noise, and without any sound interruption thanks to the innovative circuit topology. In fact, in hybrid vehicles, the engine ignition causes a fast increase of battery voltage which can reach 16 V in less than 10 ms.

Figure 23. Upwards fast battery transitions diagram

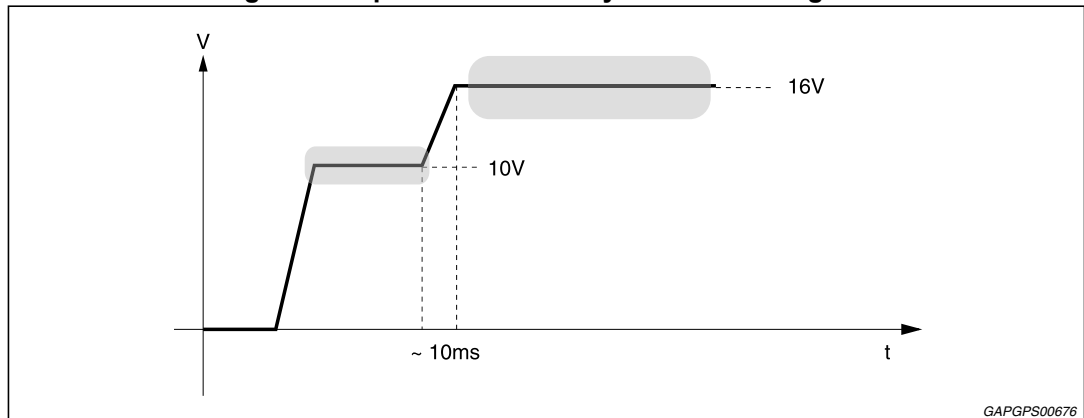

4.3 Protections

4.3.1 Short circuits and open circuit operation

When the IC detects a short circuit to ground, to V_S or across the load, the output of the amplifier is put in three-state (high impedance condition). The power stage remains in this condition until the short is removed.

In case of short circuit to ground or V_{CC} , the amplifier exits from the three-state condition only when the output returns inside the limits imposed by an internal voltage comparator.

When a short across the load is present, the power stage sees an over-current and is brought in protection mode for 100 μs . After this time, if the short circuit condition is removed the amplifier returns to play, otherwise the high impedance state is maintained and the check is repeated every 100 μs .

Disconnection of load (open load condition) doesn't damage the amplifier, which continues to play.

4.3.2 Over-voltage and load dump protection

When the battery voltage is higher than 19 V, the amplifier is switched to a high impedance state. It stops to playing till the supply voltage returns in the permitted range.

The amplifier is protected against load dump surges having amplitude as high as 50 V and a rising time lower than 5 ms (see *Figure 24*).

Figure 24. Load dump protection diagram

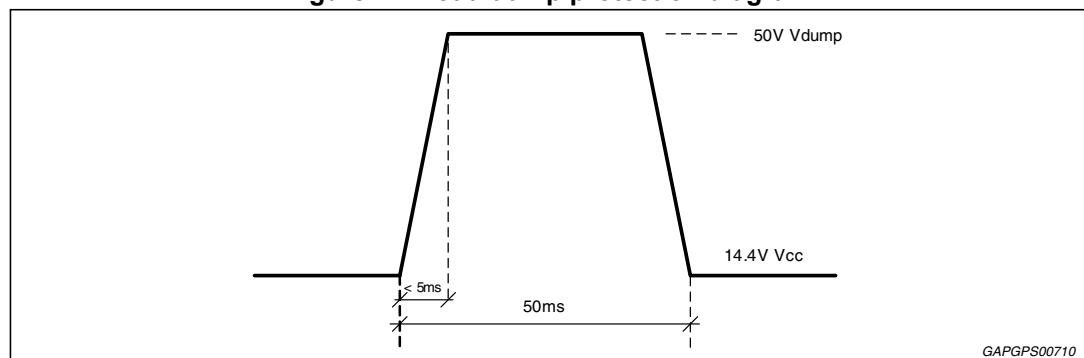

4.3.3 Thermal protection

If the junction temperature of the IC reaches $T_j = 150\text{ }^\circ C$, a smooth mute is applied to reduce output power and limit power dissipation. If this is not enough and the junction temperature continues to increase, the amplifier is switched off when reaches the maximum temperature of $170\text{ }^\circ C$.

Figure 25. Thermal protection diagram

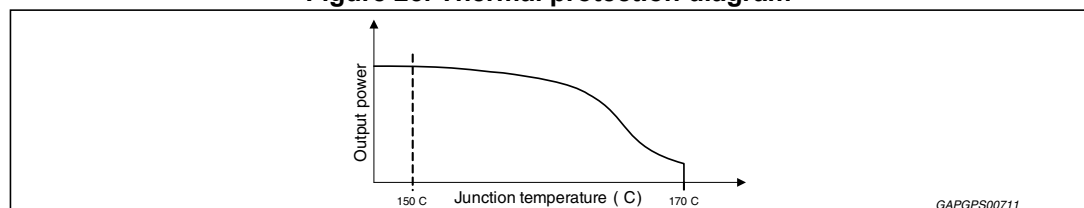

4.4 Warnings

4.4.1 DC offset detection (OD pin)

The STPA001 integrates a DC offset detector to avoid that an anomalous input DC offset is multiplied by the amplifier gain producing a dangerous large offset at the output. In fact an output offset may lead to speakers damage for overheating. The detector works with the amplifier un-muted and no signal at the inputs.

When the differential output voltage is out of a window comparator with thresholds $\pm 2V$ (typ), the OD pin is pulled down.

4.4.2 Clipping detection and diagnostics (CD-DIAG pin)

When clipping occurs, the output signal is distorted. If the signal distortion on one of the output channels exceeds 1%, the CD-DIAG pin is pulled down. This information can be sent to an audio processor in order to reduce the input signal of the amplifier and reduce the clipping. Thanks to a particular internal circuitry, the clip detector is always functional till 6.5 V.

A short to ground and short to V_{cc} is pointed out by CD-DIAG. This pin is pulled down to 0 V till these shorts are present to inform the user a protection occurred.

CD-DIAG acts also as thermal warning. In fact every time T_j exceeds 140 °C, it is pulled down to notify this occurrence.

Figure 26. Audio section waveforms

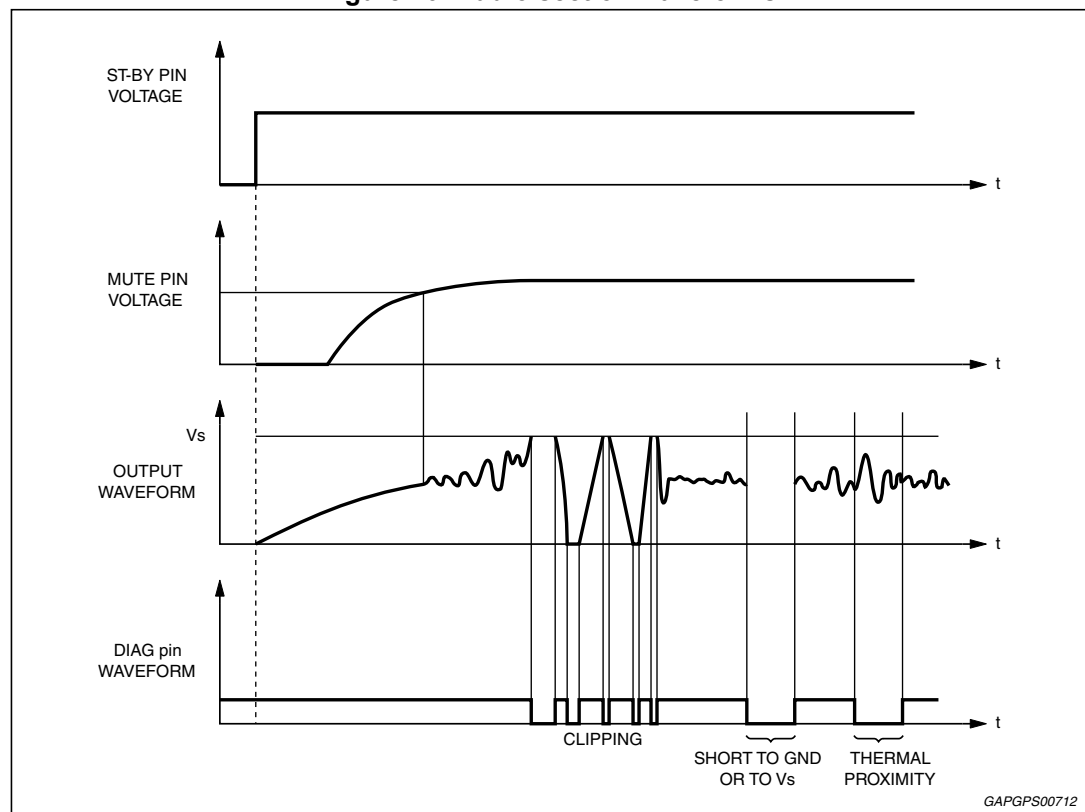

4.5 Heat sink definition

Assuming we have a maximum dissipated power of 26 W (e.g. in the worst case situation of frequent clipping occurrence), considering T_j max is 150°C and assuming ambient temperature is 70 °C, the available temperature gap for a correct dissipation is 80 °C. This means the thermal resistance of the system R_{Th} has to be $80 \text{ °C}/26 \text{ W} = 3 \text{ °C/W}$.

The junction to case thermal resistance is 1 °C/W. So the heat sink thermal resistance should be approximately 2 °C/W. This would avoid any thermal shutdown occurrence even after long-term and full-volume operation.

5 Package information

In order to meet environmental requirements, ST offers these devices in different grades of ECOPACK® packages, depending on their level of environmental compliance. ECOPACK® specifications, grade definitions and product status are available at: www.st.com.

ECOPACK® is an ST trademark.

Figure 27. Flexiwatt27 (vertical) mechanical data and package dimensions

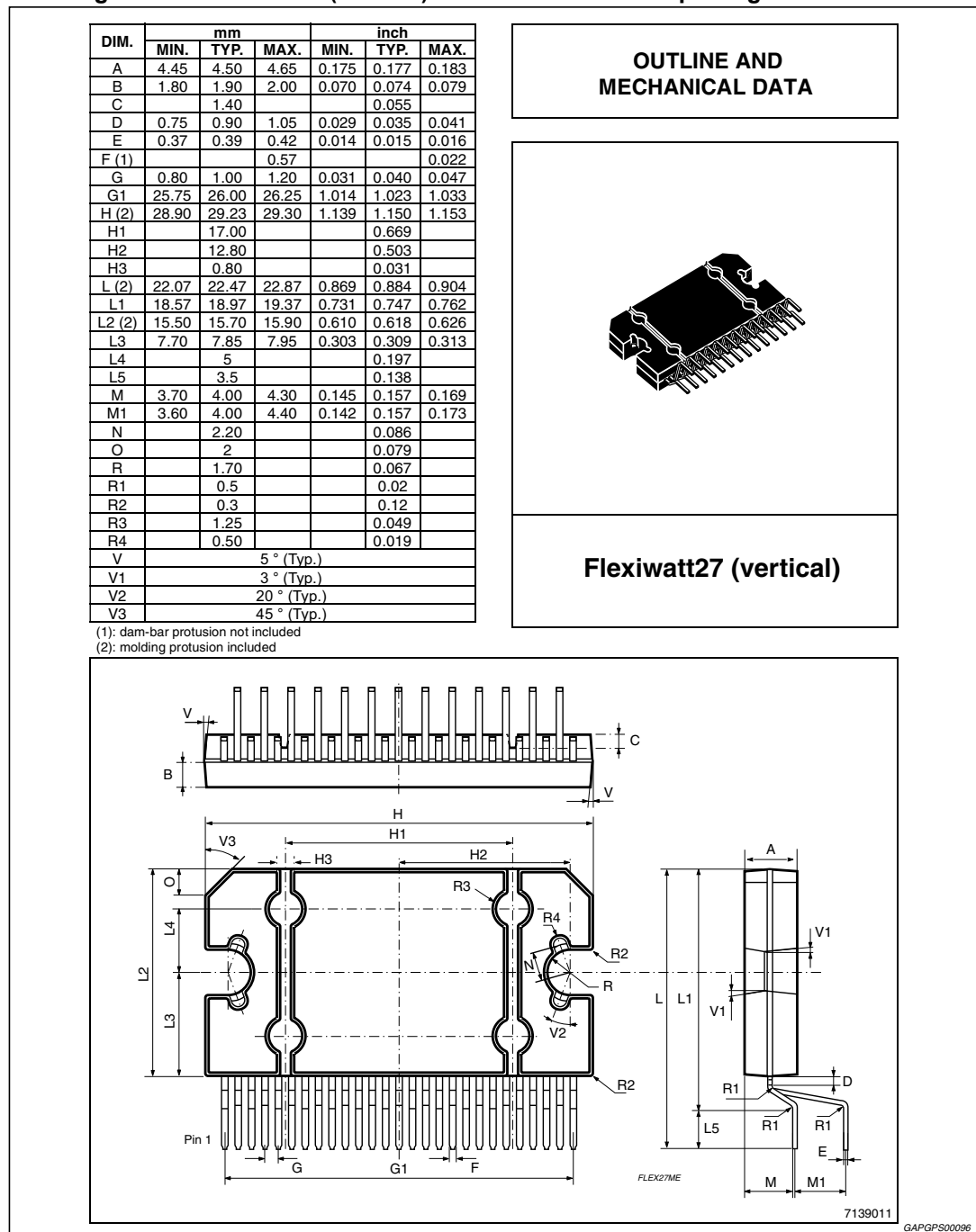
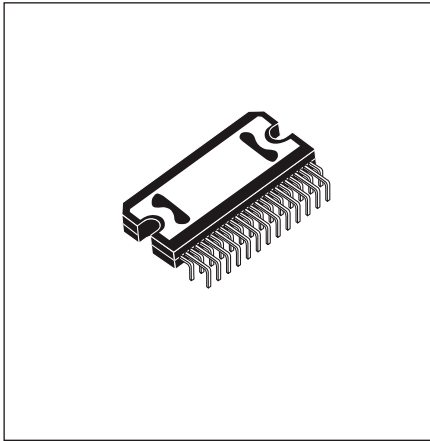

Figure 28. Flexiwatt27 (horizontal) mechanical data and package dimensions

DIM.	mm			inch		
	MIN.	TYP.	MAX.	MIN.	TYP.	MAX.
A	4.45	4.50	4.65	0.175	0.177	0.183
B	1.80	1.90	2.00	0.070	0.074	0.079
C		1.40			0.055	
D		2.00			0.079	
E	0.37	0.39	0.42	0.014	0.015	0.016
F (1)			0.57			0.022
G	0.75	1.00	1.25	0.0295	0.040	0.0492
G1	25.70	26.00	26.30	1.0118	1.023	1.0354
H (2)	28.90	29.23	29.30	1.139	1.150	1.153
H1		17.00			0.669	
H2		12.80			0.503	
H3		0.80			0.031	
L (2)	21.64	22.04	22.44	0.852	0.868	0.883
L1	10.15	10.5	10.85	0.40	0.413	0.427
L2 (2)	15.50	15.70	15.90	0.610	0.618	0.626
L3	7.70	7.85	7.95	0.303	0.309	0.313
L4		5			0.197	
L5	5.15	5.45	5.85	0.203	0.214	0.23
L6	1.80	1.95	2.10	0.070	0.077	0.083
M	2.75	3.00	3.50	0.108	0.118	0.138
M1		4.73			0.186	
M2		5.61			0.220	
N		2.20			0.086	
P	3.20	3.50	3.80	0.126	0.138	0.15
R		1.70			0.067	
R1		0.50			0.02	
R2		0.30			0.12	
R3		1.25			0.049	
R4		0.50			0.02	
V	5° (Typ.)					
V1	3° (Typ.)					
V2	20° (Typ.)					
V3	45° (Typ.)					

OUTLINE AND MECHANICAL DATA



Flexiwatt27 (Horizontal)

(1): dam-bar protusion not included; (2): molding protusion included

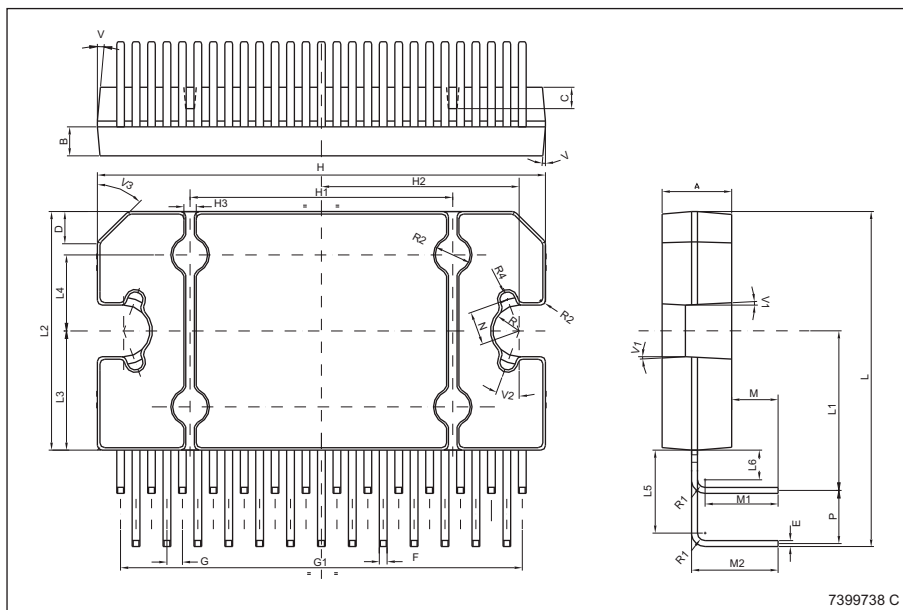

7399738 C GAPGPS00095

Figure 29. Flexiwatt25 vertical mechanical data and package dimensions

DIM.	mm			inch		
	MIN.	TYP.	MAX.	MIN.	TYP.	MAX.
A	4.45	4.50	4.65	0.175	0.177	0.183
B	1.80	1.90	2.00	0.070	0.074	0.079
C		1.40			0.055	
D	0.75	0.90	1.05	0.029	0.035	0.041
E	0.37	0.39	0.42	0.014	0.015	0.016
F (1)			0.57			0.022
G	0.80	1.00	1.20	0.031	0.040	0.047
G1	23.75	24.00	24.25	0.935	0.945	0.955
H (2)	28.90	29.23	29.30	1.139	1.150	1.153
H1		17.00			0.669	
H2		12.80			0.503	
H3		0.80			0.031	
L (2)	22.07	22.47	22.87	0.869	0.884	0.904
L1	18.57	18.97	19.37	0.731	0.747	0.762
L2 (2)	15.50	15.70	15.90	0.610	0.618	0.626
L3	7.70	7.85	7.95	0.303	0.309	0.313
L4		5			0.197	
L5		3.5			0.138	
M	3.70	4.00	4.30	0.145	0.157	0.169
M1	3.60	4.00	4.40	0.142	0.157	0.173
N		2.20			0.086	
O		2			0.079	
R		1.70			0.067	
R1		0.5			0.02	
R2		0.3			0.12	
R3		1.25			0.049	
R4		0.50			0.019	
V			5° (Typ.)			
V1			3° (Typ.)			
V2			20° (Typ.)			
V3			45° (Typ.)			

OUTLINE AND MECHANICAL DATA

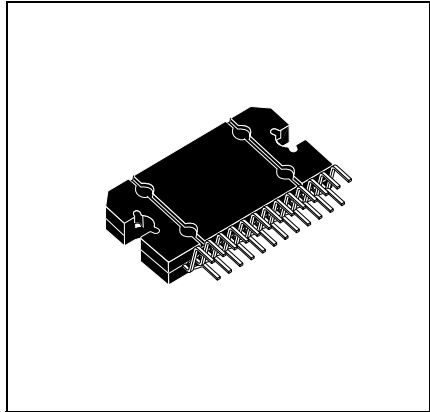

Flexiwatt25 (vertical)

(1): dam-bar protusion not included
 (2): molding protusion included

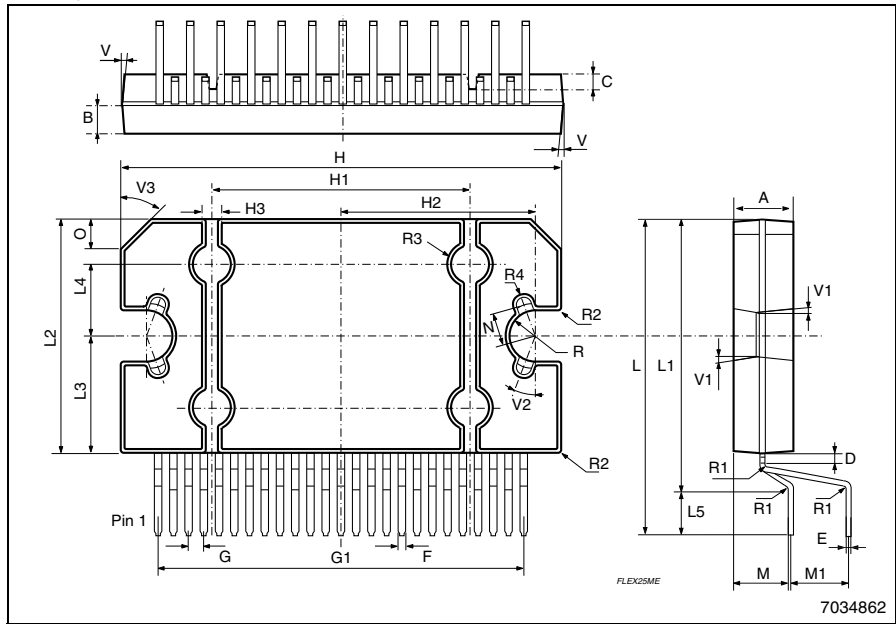

GAPGPS00669

Figure 30. Flexiwatt25 (horizontal) mechanical data and package dimensions

DIM.	mm			inch		
	MIN.	TYP.	MAX.	MIN.	TYP.	MAX.
A	4.45	4.50	4.65	0.175	0.177	0.183
B	1.80	1.90	2.00	0.070	0.074	0.079
C		1.40			0.055	
D		2.00			0.079	
E	0.37	0.39	0.42	0.014	0.015	0.016
F ⁽¹⁾			0.57			0.022
G	0.75	1.00	1.25	0.029	0.040	0.049
G1	23.70	24.00	24.30	0.933	0.945	0.957
H ⁽²⁾	28.90	29.23	29.30	1.139	1.150	1.153
H1		17.00			0.669	
H2		12.80			0.503	
H3		0.80			0.031	
L ⁽²⁾	21.64	22.04	22.44	0.852	0.868	0.883
L1	10.15	10.5	10.85	0.40	0.413	0.427
L2 ⁽²⁾	15.50	15.70	15.90	0.610	0.618	0.626
L3	7.70	7.85	7.95	0.303	0.309	0.313
L4		5			0.197	
L5	5.15	5.45	5.85	0.203	0.214	0.23
L6	1.80	1.95	2.10	0.070	0.077	0.083
M	2.75	3.00	3.50	0.108	0.118	0.138
M1		4.73			0.186	
M2		5.61			0.220	
N		2.20			0.086	
P	3.20	3.50	3.80	0.126	0.138	0.15
R		1.70			0.067	
R1		0.50			0.02	
R2		0.30			0.12	
R3		1.25			0.049	
R4		0.50			0.02	
V				5° (Typ.)		
V1				3° (Typ.)		
V2				20° (Typ.)		
V3				45° (Typ.)		

(1): Dam-bar protusion not included; (2): Molding protusion included.

OUTLINE AND MECHANICAL DATA

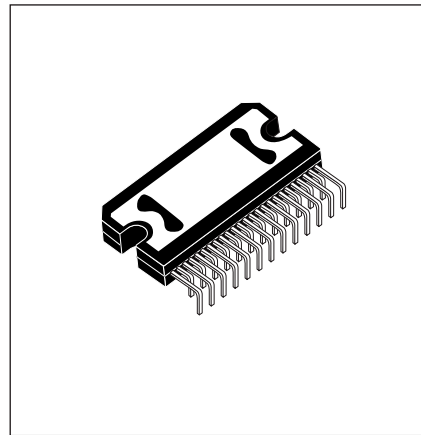

Flexiwatt25 (Horizontal)

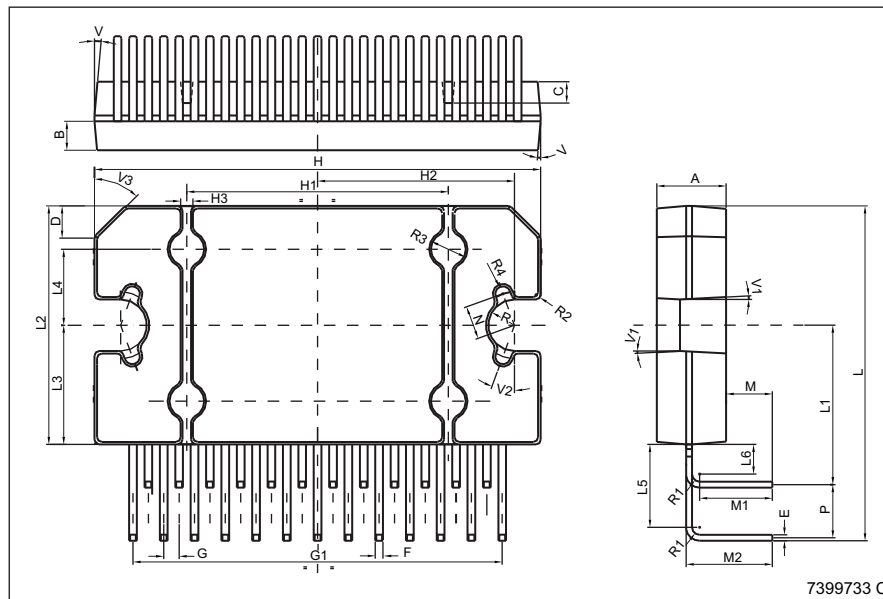

7399733 C

GAPGPS01239

6 Revision history

Table 6. Document revision history

Date	Revision	Changes
03-Apr-2012	1	Initial release.
10-Sep-2012	2	Updated <i>Table 3: Absolute maximum ratings on page 9.</i>
14-Nov-2012	3	Updated: <i>Features on page 1;</i> <i>Section 1.1: Block diagram and application circuit;</i> <i>Section 3.3: Electrical characteristics;</i> <i>Section 4.4.2: Clipping detection and diagnostics (CD-DIAG pin) on page 19;</i> Added <i>Section 3.4: Electrical characteristics curves.</i>
05-Sep-2013	4	Updated <i>Figure 17 & 18.</i>
18-Sep-2013	5	Updated Disclaimer.
05-Sep-2014	6	Updated <i>Table 1: Device summary on page 1.</i> Added <i>Figure 30: Flexiwatt25 (horizontal) mechanical data and package dimensions on page 24.</i>
27-Oct-2014	7	Updated <i>Table 1: Device summary on page 1.</i> Added <i>Figure 28: Flexiwatt27 (horizontal) mechanical data and package dimensions on page 22</i>

IMPORTANT NOTICE – PLEASE READ CAREFULLY

STMicroelectronics NV and its subsidiaries ("ST") reserve the right to make changes, corrections, enhancements, modifications, and improvements to ST products and/or to this document at any time without notice. Purchasers should obtain the latest relevant information on ST products before placing orders. ST products are sold pursuant to ST's terms and conditions of sale in place at the time of order acknowledgement.

Purchasers are solely responsible for the choice, selection, and use of ST products and ST assumes no liability for application assistance or the design of Purchasers' products.

No license, express or implied, to any intellectual property right is granted by ST herein.

Resale of ST products with provisions different from the information set forth herein shall void any warranty granted by ST for such product.

ST and the ST logo are trademarks of ST. All other product or service names are the property of their respective owners.

Information in this document supersedes and replaces information previously supplied in any prior versions of this document.

© 2014 STMicroelectronics – All rights reserved