

Features

- Glass Passivated Die Construction
- Diffused Junction
- Super-Fast Switching Times for High Efficiency
- High Current Capability and Low Forward Voltage Drop
- Surge Overload Rating to 125A Peak
- Low Reverse Leakage Current
- Plastic Material: UL Flammability Classification Rating 94V-0

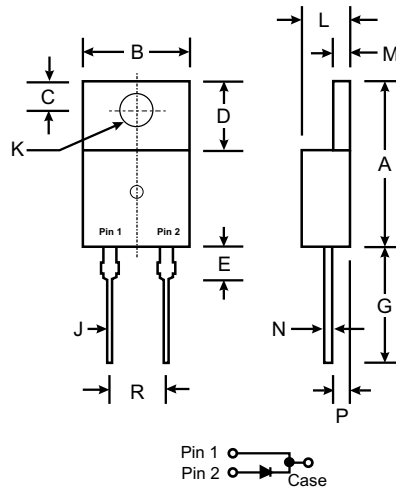

TO-220AC		
Dim	Min	Max
A	14.22	15.88
B	9.65	10.67
C	2.54	3.43
D	5.84	6.86
E	—	6.35
G	12.70	14.73
J	0.51	1.14
K	3.53 \varnothing	4.09 \varnothing
L	3.56	4.83
M	1.14	1.40
N	0.30	0.64
P	2.03	2.92
R	4.83	5.33
All Dimensions in mm		

Mechanical Data

- Case: Molded Plastic
- Terminals: Plated Leads Solderable per MIL-STD-202, Method 208
- Polarity: See Diagram
- Weight: 2.24 grams (approx.)
- Mounting Position: Any
- Marking: Type Number

Maximum Ratings and Electrical Characteristics @ T_A = 25°C unless otherwise specified

Single phase, half wave, 60Hz, resistive or inductive load.
For capacitive load, derate current by 20%.

Characteristic	Symbol	STPR 805DF	STPR 810DF	STPR 815DF	STPR 820DF	STPR 830DF	STPR 840DF	STPR 850DF	STPR 860DF	Unit
Peak Repetitive Reverse Voltage Working Peak Reverse Voltage DC Blocking Voltage	V _{RRM} V _{RWM} V _R	50	100	150	200	300	400	500	600	V
RMS Reverse Voltage	V _{R(RMS)}}	35	70	105	140	210	280	350	420	V
Average Rectified Output Current (Note 1) @ T _C = 100°C	I _O	8.0								A
Non-Repetitive Peak Forward Surge Current 8.3ms single half sine-wave superimposed on rated load (JEDEC Method)	I _{FSM}	125								A
Forward Voltage @ I _F = 8.0A	V _{FM}	0.95		1.3		1.5			V	
Peak Reverse Current @ T _C = 25°C at Rated DC Blocking Voltage @ T _C = 100°C	I _{RM}	5.0				500				μA
Reverse Recovery Time (Note 2)	t _{rr}	35			50				ns	
Typical Junction Capacitance (Note 3)	C _j	85						60		pF
Typical Thermal Resistance Junction to Case	R _{θJC}	6.3								°C/W
Operating and Storage Temperature Range	T _j , T _{STG}	-65 to +150								°C

- Notes:
1. Case mounted on heatsink.
 2. Measured with I_F = 0.5A, I_R = 1.0A, I_{rr} = 0.25A.
 3. Measured at 1.0MHz and Applied Reverse Voltage of 4.0V DC.

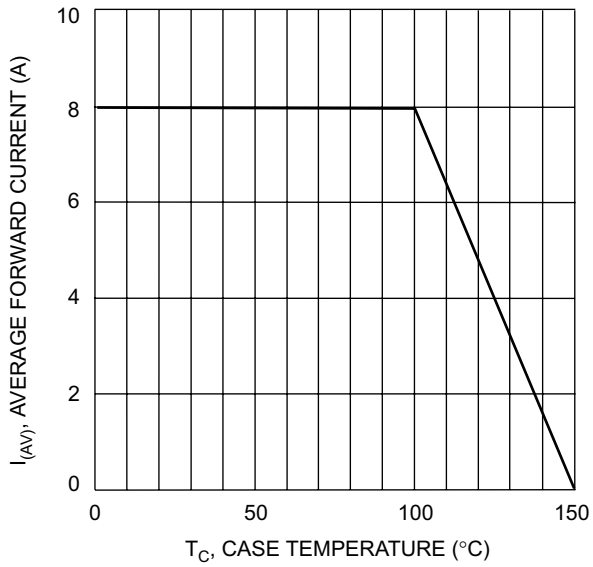

Fig. 1 Forward Current Derating Curve

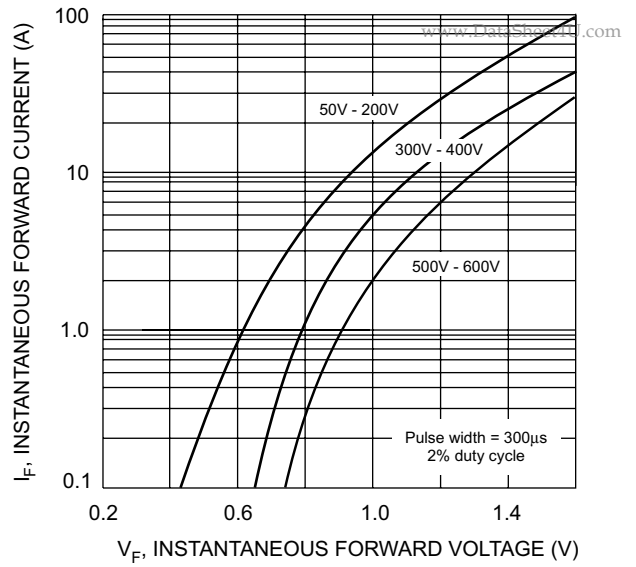

Fig. 2 Typical Forward Characteristics

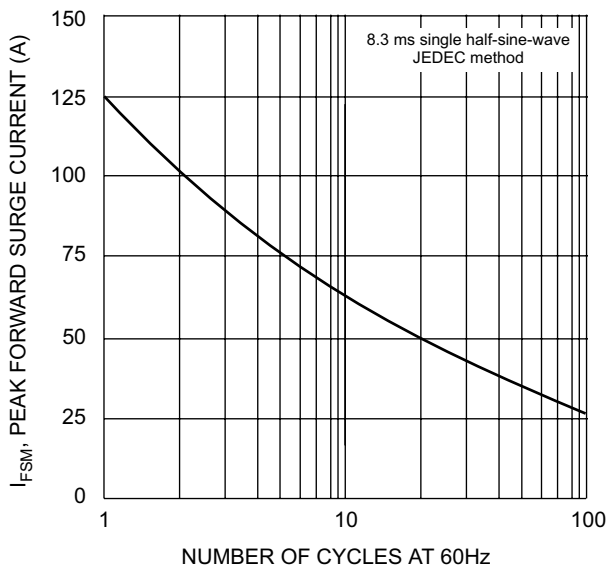

Fig. 3 Max Non-Repetitive Surge Current

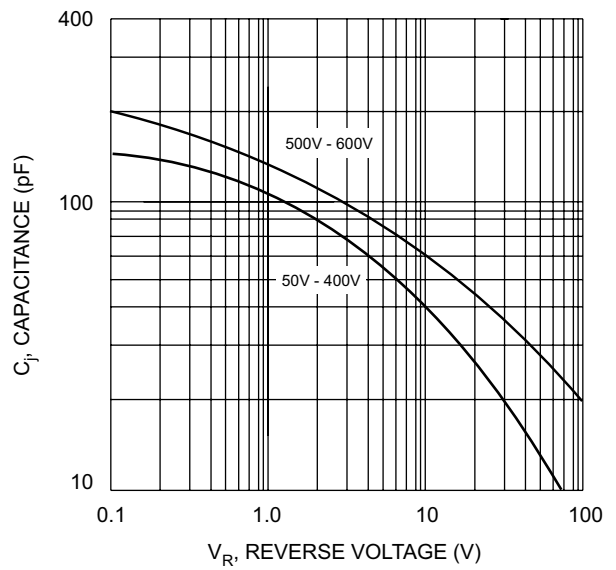

Fig. 4 Typical Junction Capacitance

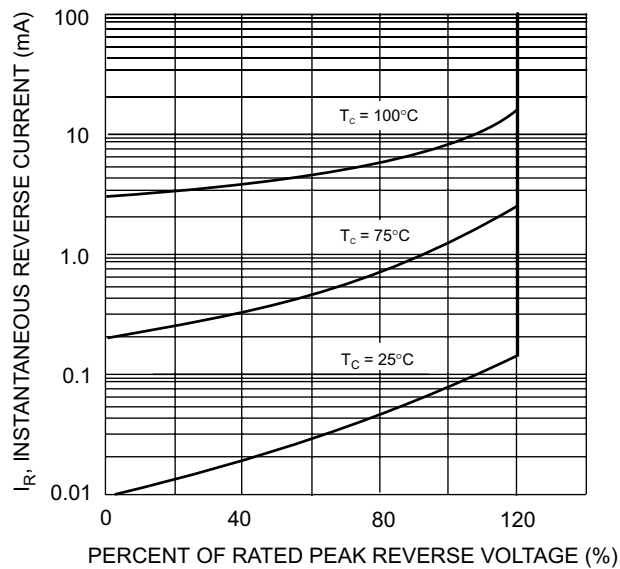

Fig. 5 Typical Reverse Characteristics