

STR-S6411 AND STR-S6411F

OFF-LINE SWITCHING REGULATORS - WITH POWER MOSFET OUTPUT

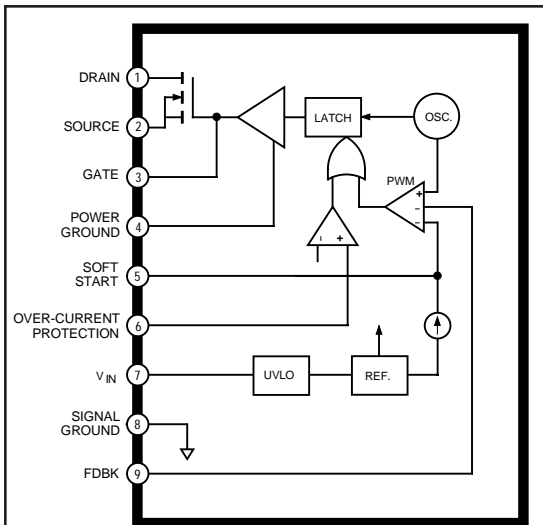

Dwg. PK-003

These devices are specifically designed to meet the requirements for increased integration and reliability in off-line flyback (STR-S6411) and forward (STR-S6411F) converters operating in a fixed-frequency PWM mode. Each device incorporates the primary control and drive circuits with an avalanche-rated high-voltage power MOSFET. Crucial system parameters such as switching frequency and maximum duty cycle are fixed during manufacture. The STR-S6411 and STR-S6411F differ only in their maximum duty cycle. Control circuit decoupling and layout are optimized within each device.

Cycle-by-cycle and average-current limiting, soft start, under-voltage lockout with hysteresis, and thermal shutdown protect the device during all normal and overload conditions. The performance and reliability of these devices, and their variable-frequency counterparts, has been proven in substantial volume production.

The requirements of high dielectric isolation and low transient thermal impedance and steady-state thermal resistance are satisfied in an over-molded, 9-pin single in-line power package.

ABSOLUTE MAXIMUM RATINGS

Supply Voltage, V_{IN}	35 V
Drain-Source Voltage, V_{DS}	800 V
Drain Current, I_D	
continuous	±5 A
single pulse, $t_w \leq 1$ ms	±20 A
Avalanche Energy, E_A	
single pulse	400 mJ
Gate-Source Voltage, V_{GS}	±20 V
Gate-Drive Current Range,	
I_G	-0.7 A to +1.5 A
Over-Current Protection Voltage Range,	
V_{OCP}	-0.3 V to +4.0 V
Insulation RMS Voltage,	
$V_{WM(RMS)}$	2000 V
Package Power Dissipation,	
P_D	See Graph
FET Channel Temperature, T_J	+150°C
Internal Frame Temperature, T_F ...	+125°C
Operating Temperature Range,	
T_A	-20°C to +125°C
Storage Temperature Range,	
T_{stg}	-30°C to +125°C

FEATURES

- PWM Flyback Conversion or Forward Conversion
- Output Power to 250 W
- Pulse-by-Pulse Current Limiting
- Fixed-Frequency 100 kHz PWM
- Avalanche-Rated Power MOSFET Switch
- Soft Start
- Internal Under-Voltage Lockout and Thermal Shutdown
- Low External Component Count
- Over-Molded SIP with Isolated Heat Spreader

Always order by complete part number:

STR-S6411 or **STR-S6411F**.

STR-S6411 AND STR-S6411F OFF-LINE SWITCHING REGULATORS

FUNCTIONAL BLOCK DIAGRAM

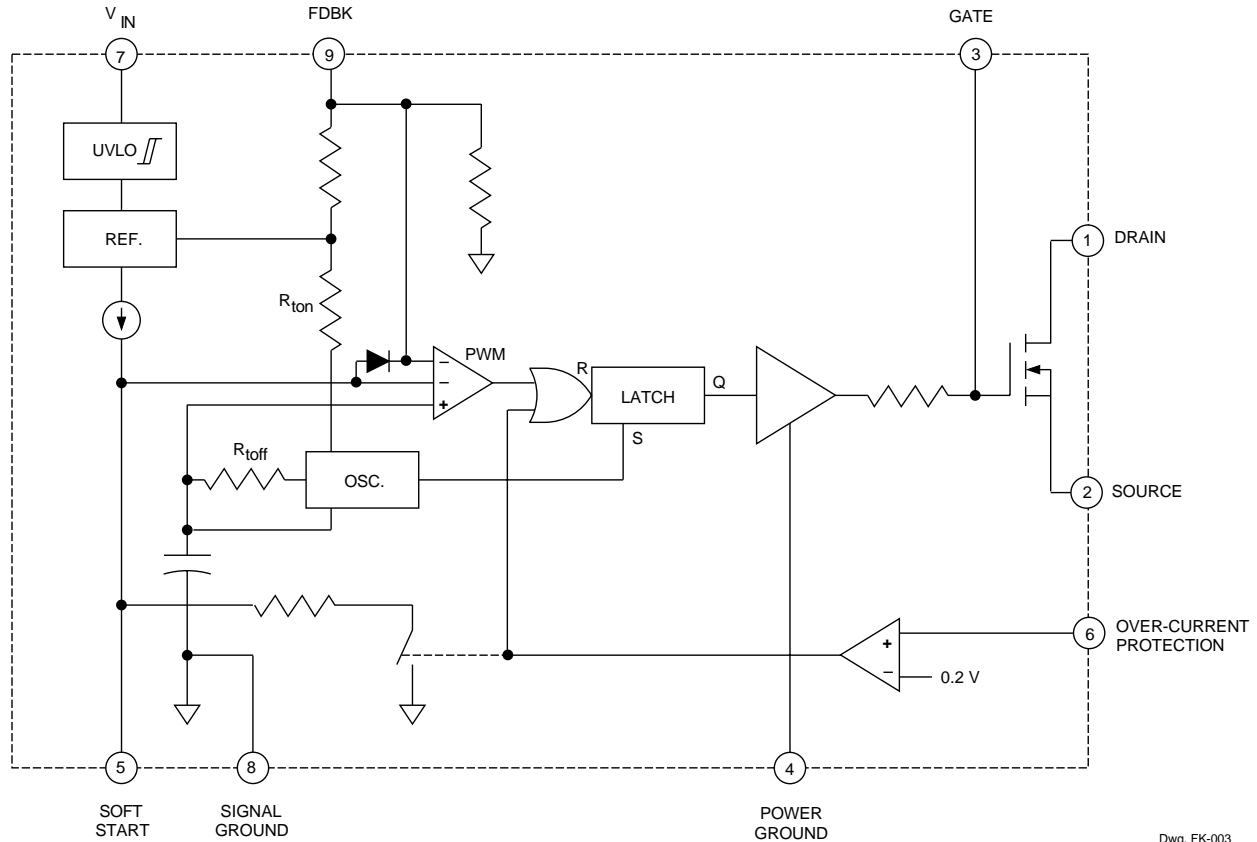

Dwg. FK-003

ALLOWABLE PACKAGE POWER DISSIPATION

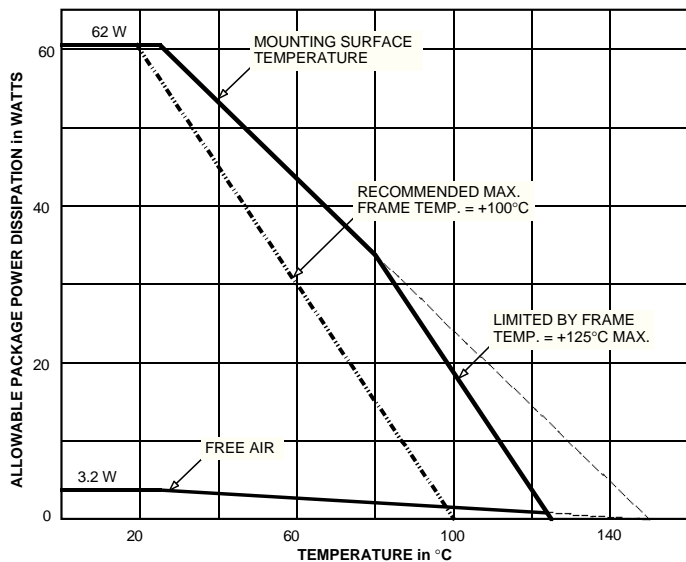

www.DataSheet4U.com

Dwg. GK-003

MAXIMUM SAFE OPERATING AREA

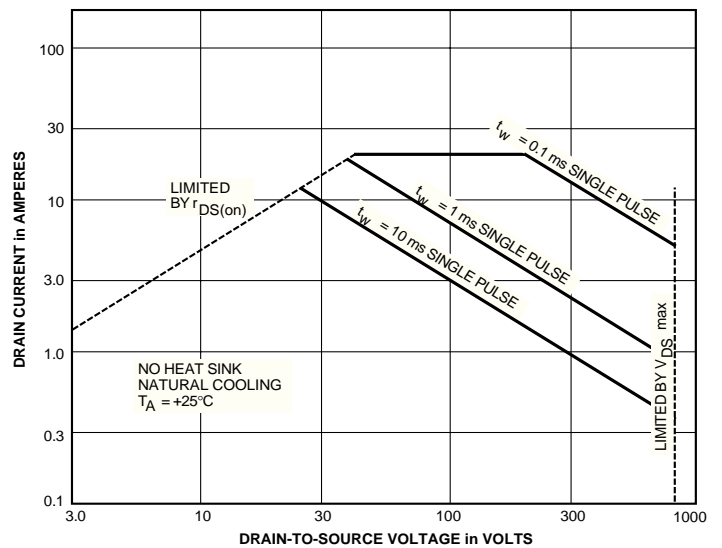

Dwg. GK-004-1



115 Northeast Cutoff, Box 15036
Worcester, Massachusetts 01615-0036 (508) 853-5000
Copyright © 1994 Allegro MicroSystems, Inc.



STR-S6411 AND STR-S6411F OFF-LINE SWITCHING REGULATORS

ALLOWABLE AVALANCHE ENERGY

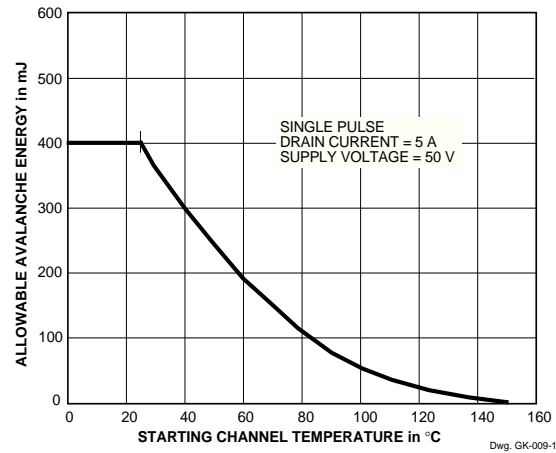

ELECTRICAL CHARACTERISTICS at $T_A = +25^\circ\text{C}$, $V_{IN} = 17\text{ V}$, voltage measurements are referenced to Signal Ground (pin 8) (unless otherwise noted).

Characteristic	Symbol	Test Conditions	Limits			Units
			Min.	Typ.	Max.	
On-State Voltage	V_{INT}	Turn-on, increasing V_{IN}	14.4	16	17.6	V
Under-Voltage Lockout	V_{INQ}	Turn-off, decreasing V_{IN}	8.4	9.4	10.4	V
FET Leakage Current	I_{DSS}	$V_{DS} = 800\text{ V}$	–	–	1.2	mA
FET ON Resistance	$r_{DS(on)}$	$V_{GS} = 10\text{ V}$, $I_D = 3\text{ A}$	–	1.8	2.2	Ω
Forward Transconductance	g_{fs}	$V_{GS} = 10\text{ V}$, $I_D = 3\text{ A}$	3.0	–	–	S
FET Input Capacitance	C_{iss}	$V_{DS}=10\text{ V}$, $V_{GS}=0\text{ V}$, $f=1\text{ MHz}$	–	1800	–	pF
Propagation Delay Time	t_{phl}	Turn-on, 10% V_{GS} to 10% V_{DS}	–	60	–	ns
	t_{plh}	Turn-off, 90% V_{GS} to 90% V_{DS}	–	140	–	ns
Oscillator Frequency	f_{osc}		93	100	107	kHz
Maximum ON Time	t_{on}	STR-S6411	5.1	5.7	6.5	μs
		STR-S6411F	3.8	4.5	5.2	μs
Over-Current Threshold	$V_{OCP(th)}$		160	200	240	mV
OCP Current	I_{OCP}		-250	-400	-550	μA
Feedback Current	I_{FDBK}		–	-1.8	–	mA
Soft Start Threshold Voltage	$V_{SS(th)}$		–	–	0.4	V
Soft Start Current	I_{SS}	$V_{SS} = 0\text{ V}$	–	-100	–	μA
Power Ground Current	I_{PG}	$t_w = 200\text{ ns}$	–	-1.0	-1.5	A
Supply Current	$I_{IN(ON)}$	Operating	–	23	–	mA
	$I_{IN(OFF)}$	Start up, $V_{IN} = 12\text{ V}$	–	–	500	μA
Insulation RMS Voltage	$V_{WM(RMS)}$	All terminals simultaneous reference metal plate against backside	2000	–	–	V
Thermal Resistance	$R_{\theta JM}$	FET channel to mounting surface	–	2.0	–	$^\circ\text{C/W}$

NOTES: Negative current is defined as coming out of (sourcing) the specified device terminal.

Typical Data is for design information only.

STR-S6411 AND STR-S6411F OFF-LINE SWITCHING REGULATORS

TYPICAL CHARACTERISTICS

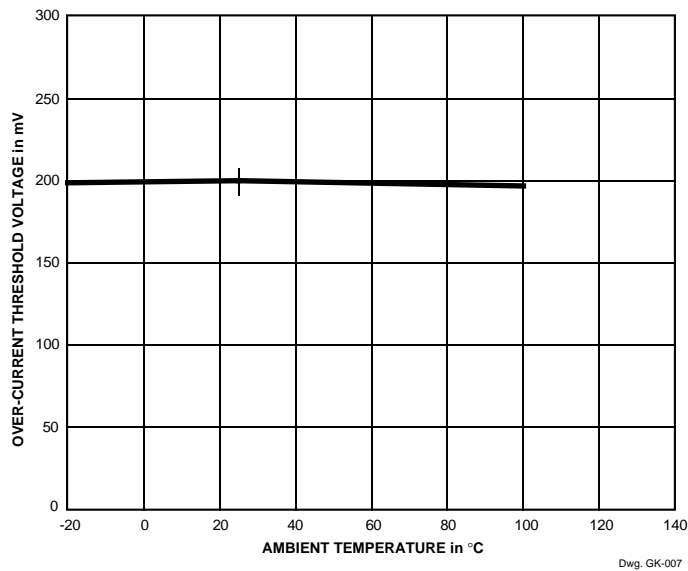
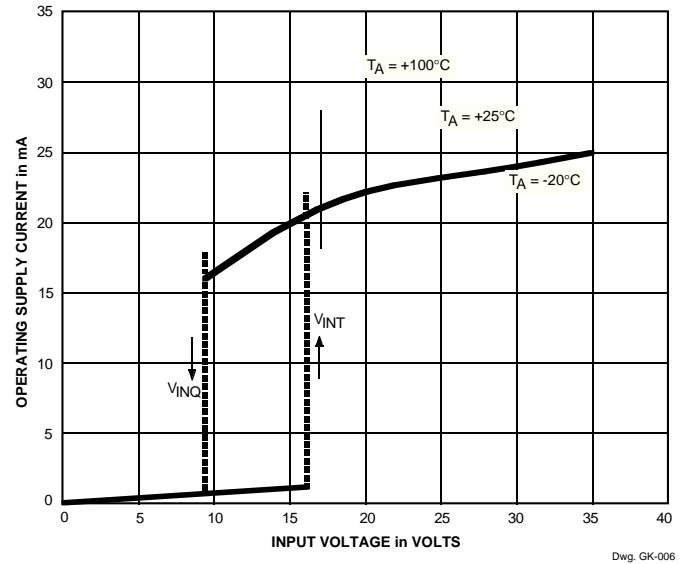
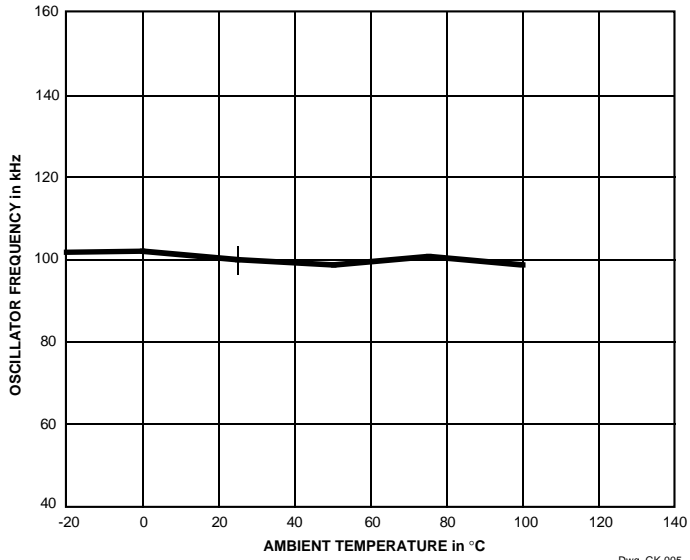

www.DataSheet4U.com

STR-S6411 AND STR-S6411F OFF-LINE SWITCHING REGULATORS

TYPICAL PWM FLYBACK CONVERSION USING STR-S6411

WARNING: lethal potentials are present. See text.

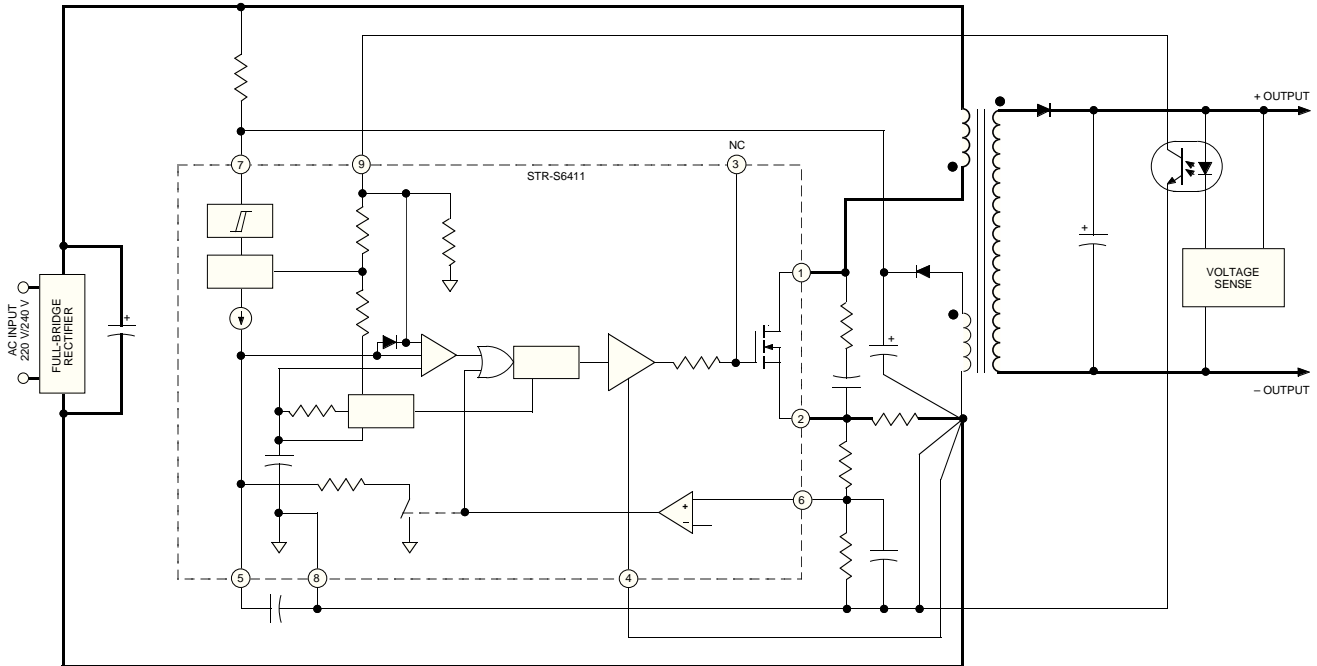

Dwg. EK-003-2

TYPICAL PWM FORWARD CONVERSION USING STR-S6411F

WARNING: lethal potentials are present. See text.

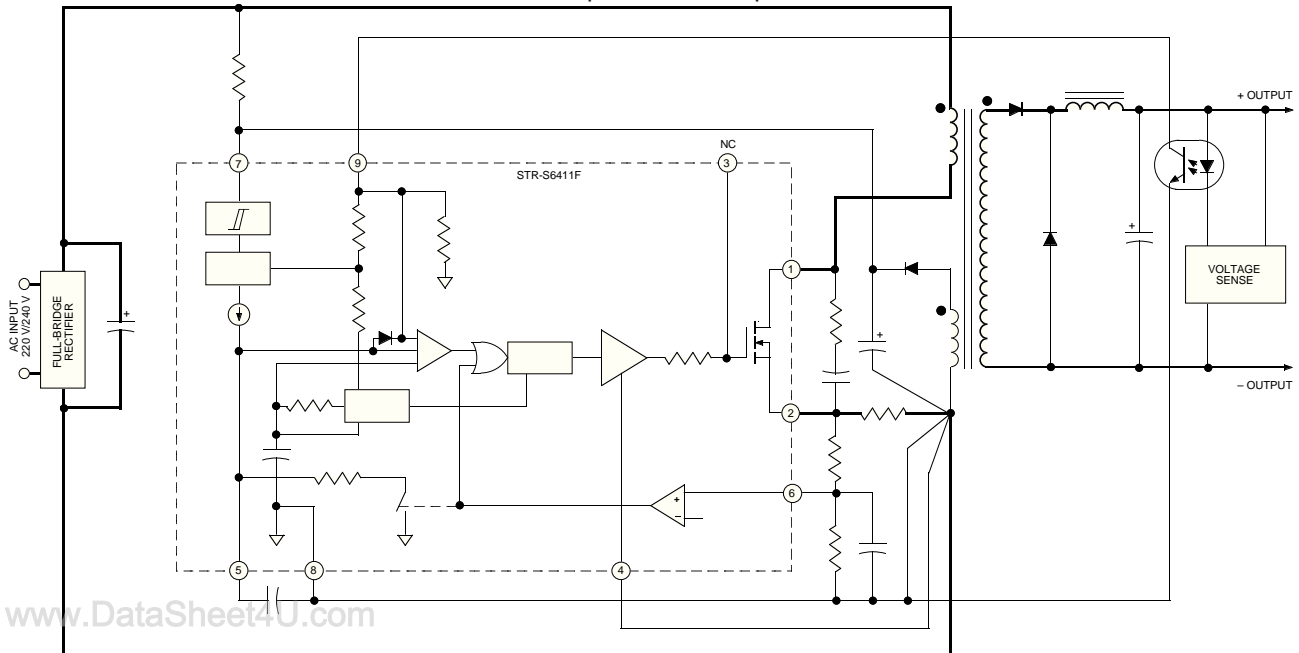

Dwg. EK-003-3

STR-S6411 AND STR-S6411F OFF-LINE SWITCHING REGULATORS

APPLICATIONS INFORMATION

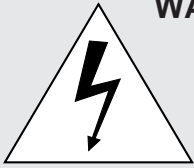

WARNING — These devices are designed to be operated at lethal voltages and energy levels. Circuit designs that embody these components must conform with applicable safety requirements. Precautions must be taken to prevent accidental contact with power-line potentials. Do not connect grounded test equipment.

The use of an isolation transformer is recommended during circuit development and breadboarding.

The power MOSFET outputs of these devices are similar to the International Rectifier type IRFP40. These devices feature an excellent combination of fast switching, ruggedized device design, low on-resistance, and cost effectiveness.

Recommended mounting hardware torque:

4.34 - 5.79 lbf•ft (6 – 8 kg•cm or 0.588 – 0.784 Nm).

Recommended metal-oxide-filled, alkyl-degenerated oil base, silicone grease:

Dow Corning 340, or equivalent

Dimensions in Inches (for reference only)

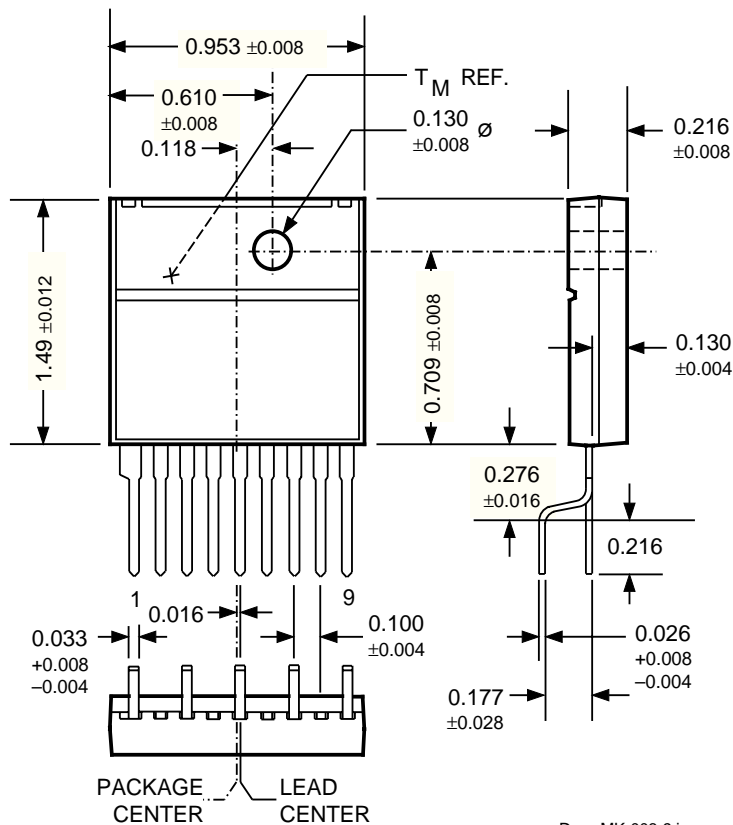

Dwg. MK-003-9 in

www.DataSheet4U.com

NOTE: Exact body and lead configuration at vendor's option within limits shown.

STR-S6411 AND STR-S6411F OFF-LINE SWITCHING REGULATORS

Dimensions in Millimeters (controlling dimensions)

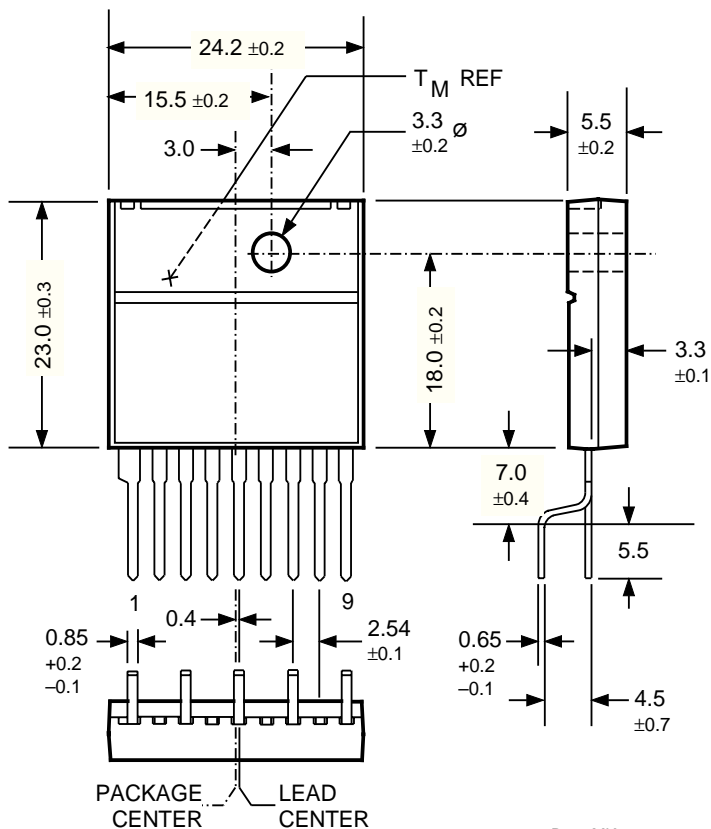

Dwg. MK-003-9 mm

NOTE: Exact body and lead configuration at vendor's option within limits shown.

The products described here are manufactured in Japan by Sanken Electric Co., Ltd. for sale by Allegro MicroSystems, Inc.

Sanken Electric Co., Ltd. and Allegro MicroSystems, Inc. reserve the right to make, from time to time, such departures from the detail specifications as may be required to permit improvements in the design of their products.

The information included herein is believed to be accurate and reliable. However, Sanken Electric Co., Ltd. and Allegro MicroSystems, Inc. assume no responsibility for its use; nor for any infringements of patents or other rights of third parties which may result from its use.

STR-S6411 AND STR-S6411F
OFF-LINE
SWITCHING REGULATORS

POWER CONVERSION/POWER MANAGEMENT
SELECTION GUIDES

SWITCHING REGULATOR PMCMs

Part Number*	Application	V _I	Max P _O		Power Switch	
3002M	5 V Switching Regulator and a 9 V Switching Regulator†	7.0-33 V	–	–	500 mA 400 mA	Bipolar Bipolar
3004M	5 V Switching Regulator and Dual 9 V Switching Regulator	7.0-33 V	–	–	500 mA 2 x 400 mA	Bipolar Bipolar
S5703	Quasi-Resonant Flyback Converter	110/120 V	140 W	500 V	6 A	Bipolar
S5707	Quasi-Resonant Flyback Converter	85-265 V 220/240V	90 W 140 W	850 V	6 A	Bipolar
S5708	Quasi-Resonant Flyback Converter	85-265 V 220/240 V	120 W 180 W	850 V	7.5 A	Bipolar
F6624	Quasi-Resonant Flyback Converter	100/120 V	130 W	450 V	0.92 Ω	MOSFET
F6626	Quasi-Resonant Flyback Converter	100/120 V	190 W	450 V	0.58 Ω	MOSFET
F6628	Quasi-Resonant Flyback Converter	100/120 V	290 W	450 V	0.35 Ω	MOSFET
F6652	Quasi-Resonant Flyback Converter	85-265 V	86 W	650 V	2.8 Ω	MOSFET
F6653	Quasi-Resonant Flyback Converter	85-265 V	120 W	650 V	1.95 Ω	MOSFET
F6654	Quasi-Resonant Flyback Converter	85-265 V	190 W	650 V	1.15 Ω	MOSFET
F6656	Quasi-Resonant Flyback Converter	85-265 V	300 W	650 V	0.71 Ω	MOSFET
F6672	Quasi-Resonant Flyback Converter	200/220 V	50 W	900 V	7.7 Ω	MOSFET
F6674	Quasi-Resonant Flyback Converter	85-265 V	76 W	900 V	4.49 Ω	MOSFET
F6676	Quasi-Resonant Flyback Converter	85-265 V	115 W	900 V	2.81 Ω	MOSFET
S6703	Quasi-Resonant Flyback Converter	110/120V	140 W	500 V	6 A	Bipolar
S6704	Quasi-Resonant Flyback Converter	110/120 V	100 W	500 V	5 A	Bipolar
S6707	Quasi-Resonant Flyback converter	85-265 V 220/240 V	90 W 140 W	850 V	6 A	Bipolar
S6708	Quasi-Resonant Flyback Converter	85-265 V 220/240 V	120 W 180 W	850 V	7.5 A	Bipolar
S6709	Quasi-Resonant Flyback Converter	85-265 V 220/240 V	160 W 220 W	850 V	10 A	Bipolar
8033S	3.3 V Switching Regulator	5.5-28 V	–	–	3 A	Bipolar
8050S	5.0 V Switching Regulator	7.0-40 V	–	–	3 A	Bipolar
8090S	9.0 V Switching Regulator	12-40V	–	–	3 A	Bipolar
8120S	12 V Switching Regulator	15-40 V	–	–	3 A	Bipolar
8150S	15 V Switching Regulator	18-40 V	–	–	3 A	Bipolar

* Complete part number includes additional characters to indicate operating temperature range and/or package style.

† Also includes linear regulator output for 15.7 V at 1.0 A.



115 Northeast Cutoff, Box 15036
 Worcester, Massachusetts 01616-0036

POWER CONVERSION/POWER MANAGEMENT
SELECTION GUIDES (CONTINUED)

