

SWITCH MODE POWER SUPPLY CONTROLLER

ADVANCE DATA

- FLYBACK CONVERTER POWER SUPPLY
- CURRENT MODE CONTROLLED SMPS
- LOW POWER CONSUMPTION
- PRIMARY AND SECONDARY REGULATION
- CONTROL OF CONDUCTION TIME AND OF SWITCHING FREQUENCY
- REVERSE CURRENT CONCEPT
- SOFTSTART
- ADJUSTABLE OVERCURRENT DETECTOR
- SECURITY FUNCTION FOR SHORT-CIRCUIT

DESCRIPTION

The STV4614C is an IC designed to drive the bipolar switching transistor in a Switch Mode Power Supply.

The STV4614C can be used in a flyback converter structure in a primary regulation or in secondary regulation with the reverse current concept.

This concept allows a secondary regulation without need of optocoupler or dedicated transformer to send a regulating signal from secondary to primary side. The regulating signal is sent through the main transformer during a dead time, after the energy have been transferred from primary to secondary side.

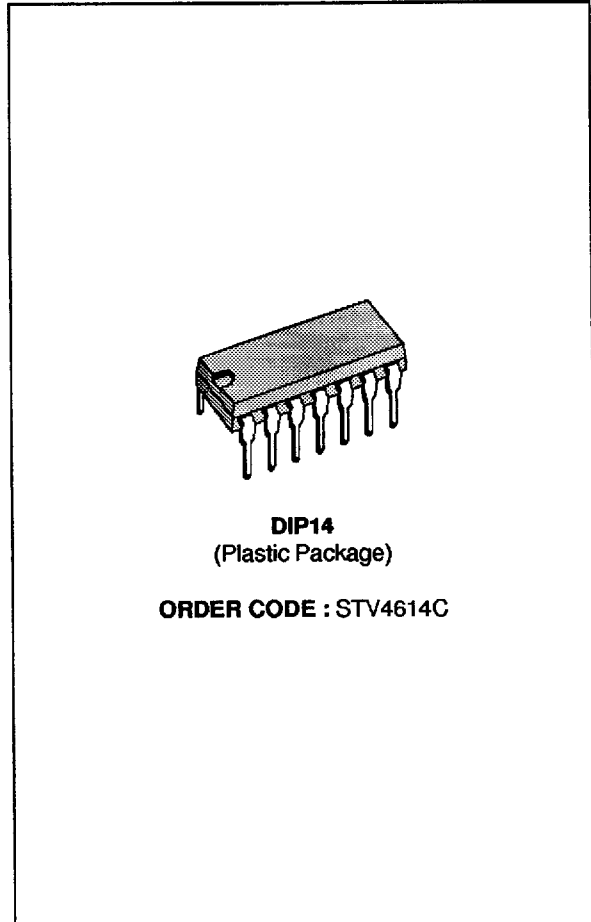

PIN CONNECTIONS

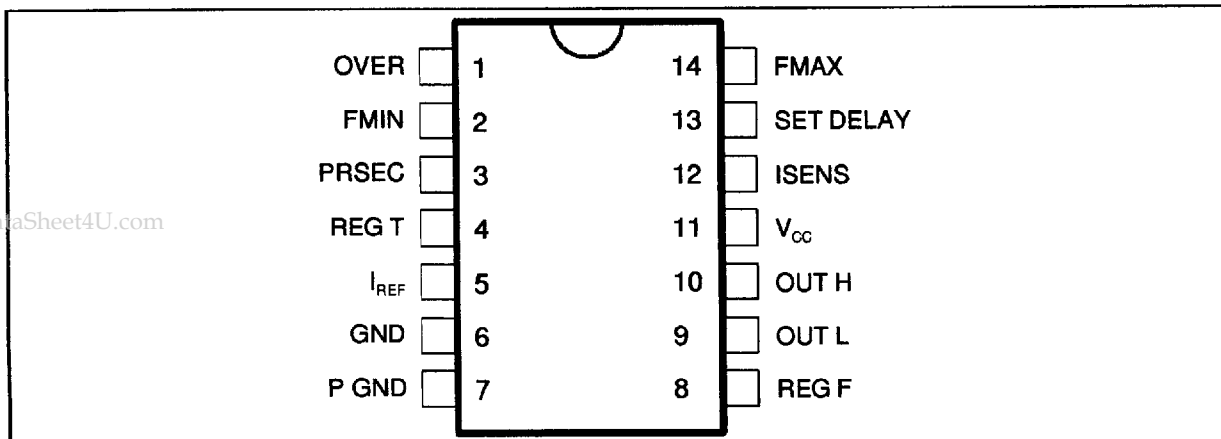

www.DataSheet4U.com

4614C-01.EPS

STV4614C

PIN DESCRIPTION

Pin N°	Symbol	Description
1	OVER	Threshold for OVERLOAD at Pin ISENS.
2	FMIN	An external resistor on this pin fixes the minimum switch frequency, reached for min load.
3	PRESEC	Input for the primary and secondary regulation information.
4	REG T	Output of the transconductance error amplifier which is internal by connected to the input of the PWM generator. The external RC network is responsible for the accuracy, dynamic and stability of the regulation loop.
5	IREF	External resistor generating a temperature independent internal current.
6	GND	Ground.
7	P GND	Power ground internally connected to the power elements.
8	REG F	Input of the frequency regulation. The information of the Pin REG T is transferred through a RC network to Pin REG F. This external RC network is responsible for the range and stability of the frequency regulation.
9	OUT L	The current at this pin has the task to collect quickly the charge carriers in the base region of the saturated switch transistor.
10	OUT H	The current at this pin is the base current of the switch transistor.
11	V _{CC}	Positive power supply.
12	ISENS	Detection of the collector current of the switch transistor to control the conduction time. To avoid damage from the IC and the application, this pin delivers a current of 200mA if the voltage becomes lower than -9.1V (security function).
13	SET DELAY	Time delay for the detection of the secondary regulation information.
14	FMAX	The threshold voltage at FMAX adjusts the output power at which the maximum frequency is reached.

4614C-01.TBL

BLOCK DIAGRAM

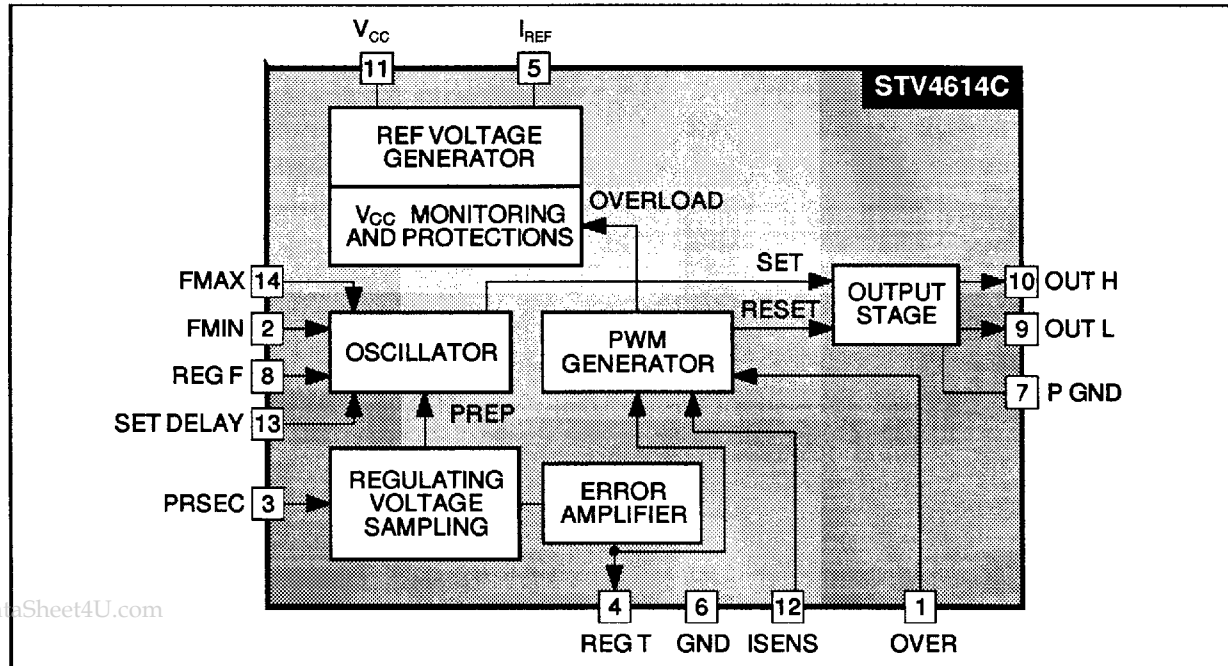

4614C-02.EPS

www.DataSheet4U.com

CIRCUIT DESCRIPTION

In free running flyback-converters, the STV4614C assumes the control of the bipolar switching transistor and all necessary regulations and monitoring functions.

It consists of seven blocks (see block diagram).

The DC Reference Generator

This block generates a reference voltage (Pin I_{REF}). Via an external resistor (15kΩ) a temperature independent current is generated.

The V_{CC} Monitoring and Protection Block

By monitoring the V_{CC} voltage, the IC determines the mode in which the circuit is working.

Five phases are monitored : start-up, initialisation, softstart, normal mode and switch off.

Also this block identifies dangerous operation conditions. E. g. if V_{CC} is too low, the IC switches off (V_{IREF} goes to zero).

The Sampling Block

This block detects the regulation information coming from a winding of the transformer and generates the sample voltage.

The IC can operate in primary or secondary regulation. By using the secondary regulation, the secondary information (V_{SEC}) has to be larger than the primary information (V_{PR}). Otherwise the SMPS is in primary regulation. This relation is fixed by external elements at Pin PRSEC.

The primary regulation information is sampled during the conduction time of the secondary diodes (secondary conduction time).

The secondary regulation information is included in the amplitude of the first ringing after the secondary conduction time. The amplitude of this ringing is processed by a circuit on the secondary side ("reverse current"). If a failure of the secondary regulation loop occurs, the IC takes over the primary regulation to limit the output voltages.

The sampling block identifies the end of the secondary conduction time. Then it generates a PREP signal for the oscillator block.

The PREP pulse is generated if following condition is valid :

$$T_x \times V_{SEC} \geq 2.10^{-7} \text{ (Volts.Second) (see Figure 1)}$$

Otherwise the PREP pulse is forced after a specified time.

The Error Amplifier

This block transforms the sample voltage into the regulation voltage (REG T, REG F). See Figures 5 and 6.

The REG T voltage determines the conduction time of the switching transistor. This REG T voltage is transmitted by an external RC network to the pin REG F, which is responsible for the switching frequency.

In case of overload or underload, the IC switches off. In normal mode, the REG T voltage is proportional to the output power.

The Oscillator

This block generates a SET signal which starts the conduction of the switching transistor. The voltages at REG F, FMAX and SET DELAY and the current generated by the resistor at FMIN determine the time T_R between the PREP pulse and the SET pulse (see normal mode).

The PWM Generator Block

This block detects the collector current of the switching transistor at pin ISENS and generates a RESET signal if this current exceeds the allowed maximum current which is proportional to the REG T voltage. This RESET starts the switch off of the switching transistor.

This block contains some safety functions : if the collector current rises too fast, OVERLOAD is activated. In case of fatal error (ISENS voltage < -9V) ISENS delivers a current which destroys an external fuse resistor to prevent further damage from the SMPS.

The Output Stage

This block drives the switching transistor. It has two separate outputs : OUT H for the conducting time and OUT L for an active switch off (collection of base charge carriers).

FUNCTIONAL DESCRIPTION

Startup Phase

Mains charges an external capacitor at Pin V_{CC} . No current is consumed by the IC.

Initialisation Phase (see Figure 2)

If V_{CC} exceeds V_{INITON} the IC starts the initialisation. When V_{CC} reaches V_{ON} , the IC switches on. The reference voltage at I_{REF} is then 3.5V. The current consumption exceeds the current which is delivered by the mains. This current must be delivered from the V_{CC} capacitor. As a result the V_{CC} voltage decreases. This initialisation ends when the V_{CC} voltage decreases below the V_{ENDIN} voltage. Note : during the initialisation phase no output pulses are generated.

Softstart

When the V_{CC} voltage is lower than V_{ENDIN} voltage, the IC delivers pulses to drive the switching transistor. The power transmission is increased slowly. The velocity of the softstart is fixed internally.

The stored energy in the V_{CC} capacitor supplies the IC during softstart. Afterwards the IC is supplied by a transformer winding.

Normal Mode Phase

If the output voltages of the SMPS have reached their nominal values, the IC enters the normal mode operation.

Timing diagram

A typical waveform of PRSEC signal is shown in Figure 1. The cycle time T consists of four parts :

- T_{ON} time (V_{PRSEC} low) : the switching transistor is on and the current flows into the transformer.
- T_P time (V_{PRSEC} high) : the switching transistor is off and the current flows out of the transformer through the secondary diodes.
- T_D time (V_{PRSEC} around zero) : the transformer is free oscillating. This time includes a fixed time delay and an adjustable delay (Pin SET DELAY). This T_D time defines the earliest start of a new cycle. This ensures an energy free transformer and a proper detection of the secondary regulation information.
- T_R time (still free oscillating of the transformer) : this time results of the frequency regulation. Its value is defined by the following formula :

$$T_R = 5 \cdot 10^{-4} \times R_{FMIN} \times (V_{FMAX} + 0.7V - V_{REGF})$$
 with T_R in μs , R_{FMIN} in Ω and V in Volt.
 This equation is only valid for $V_{REGF} > 0.9V$ and $T_R > 0$. Otherwise $T_R = 0$.

Figure 1 : V_{PRSEC} Voltage Waveform

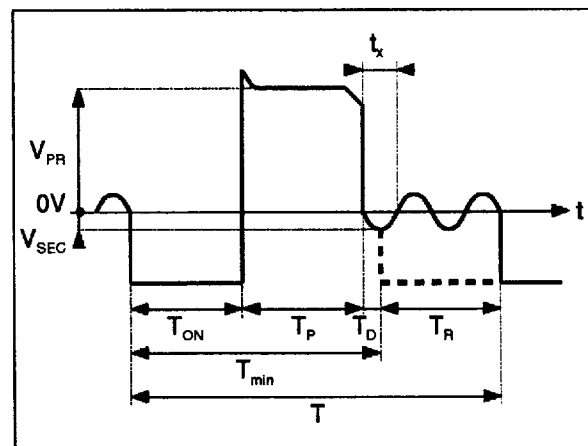

4614C-09/EP8

Frequency and T_{ON} Regulation

At low load the switching frequency and T_{ON} is proportional to the output power. If $REG T$ and $REG F$ voltage is equal to the voltage of $V_{FMAX} + 0.7V$, the switching frequency is maximum. The further increase of output power ($V_{REG T}$, $V_{REG F}$ larger than $V_{FMAX} + 0.7V$) is reached by only increasing the conduction time which reduces slightly the frequency. In this mode losses in snubber network and switching transistors are low.

The secondary information is manipulated by a circuit on the secondary side. This circuit compares the output voltage with a reference voltage and transmits a "reverse current" during the free oscillating time from the secondary to the primary side of the transformer. This "reverse current" manipulates the amplitude of the ringing, which can be sampled at the PRSEC input.

Switch Off (see Figure 3)

If the V_{CC} voltage falls under V_{OFF} or another OVERLOAD function is triggered the voltage reference (I_{REF}) and the external switch transistor are switched off. An internal current source is switched on, which discharge the external V_{CC} capacitor below V_{LOW} to ensure a new startup. Therefore the supply current delivered by the mains must be lower than this internal current (I_{LOWOFF}).

If V_{CC} voltage reaches V_{LOW} , the internal current is switched off (no current consumption) and a new startup begins.

This is a safety feature which ensures in case of failure, that the power parts cannot be overloaded, because they are off for a long time (during switch off and startup).

ABSOLUTE MAXIMUM RATINGS

Symbol	Parameter	Value	Unit
V _{CC}	Supply Voltage	20	V
T _j	Junction Temperature	125	°C
T _{stg}	Storage Temperature	-40, +150	°C
T _{oper}	Operating Temperature	0, +70	°C

4614C-02.TBL

NORMAL OPERATING CONDITIONS

Pin N°	Symbol	Min.	Typ.	Max.	Unit
1	OVER	0		3.65	V
2	FMIN	2.65		2.95	V
3	PRSEC	-4.5		4.5	V
4	REG T	0.7		4.25	V
8	REG F	0.7		4.25	V
9	OUT L	0		8	V
10	OUT H	-5		8	V
11	V _{CC}	6.3	9	17.5	V
12	ISENS	-11		0	V
13	SET DELAY	0.5		3	V
14	FMAX	0		3.65	V
4	I _{REGT}		±100		μA
3	T _{PRSEC} : Pulse Duration for Reading the Primary or Secondary Information.	500			ns
10	Minimal SET Reaction Time (V _{SET DELAY} = 0.5V)			900	ns

4614C-06.TBL

THERMAL DATA

Symbol	Parameter	Value	Unit
R _{th(j-a)}	Junction Ambient Thermal Resistance	90	°C/W

4614C-03.TBL

ELECTRICAL CHARACTERISTICS ($T_{amb} = 25^{\circ}C$)

Symbol	Parameter	Test Conditions	Min.	Typ.	Max.	Unit
PROTECTION						
VPISENS	Protection Current	If the voltage at Pin ISENS is VPISENS, a 100mA current flows out of Pin ISENS	-11	-10	-8	V
IISENS	Protection Current	Maximum current flowing out the Pin ISENS	200			mA
OVER	Voltage at Pin ISENS	IC switches off (OVERLOAD) because ISENS voltage reaches threshold, fixed by OVER voltage	-3.0		-0.5	V

DC CHARACTERISTICS

V _{CC} Characteristics in Switch On Phase (Soft Start) and in Normal Mode (Figure 2)						
I _{REF}	Reference Voltage	Bandgap is activated	3.35	3.5	3.65	V
V _{INIT/ON}	V _{CC} Voltage		15		17	V
I _{INIT/ON}	I _{CC} Current				700	μA
V _{ON}	V _{CC} Voltage	If V _{CC} exceeds V _{ON} the bandgap is activated	15.5	16.5	17.5	V
I _{ON}	Current Consumption	Startup mode : V _{CC} > V _{INIT} : bandgap on	13	21.5	28	mA
V _{ENDIN}	V _{CC} Voltage	End of initialization (normal mode) : V _{CC} < V _{ENDIN}	15		17	V
I _{ENDIN}	Current Consumption	End of initialisation : V _{CC} < V _{ENDIN}	4		10	mA
P	Power Consumption	Period time T = 7μs, T _{ON} = 3μs Base discharge time T _B = 1μs			0.6	W
V_{CC} Characteristics in Switch Off Phase (Figure 3) If V _{CC} becomes lower than V _{OFF} the reference voltage (I _{REF}) is switched off and an internal current source I _{LOWOFF} is switched on. If V _{CC} becomes lower than V _{LOW} , the internal current source I _{LOWOFF} is switched off. A new startup can begin.						
V _{OFF}	V _{CC} Voltage	V _{CC} < V _{OFF} : voltage reference is switched off	6.3	6.7	7.1	V
I _{LOWOFF}	Current Consumption	V _{LOW} < V _{CC} < V _{OFF}	6		11	mA
V _{LOW}	V _{CC} Voltage	V _{CC} < V _{LOW} : the whole IC is switched off	2.5	3	4	V
DV _{ONOF}	V _{CC} Range in Normal Mode	DV _{ONOF} = V _{ON} - V _{OFF} . Tested under application conditions.	8.8	9.5		V

Figure 2 : IC from OFF to ON and Normal Mode

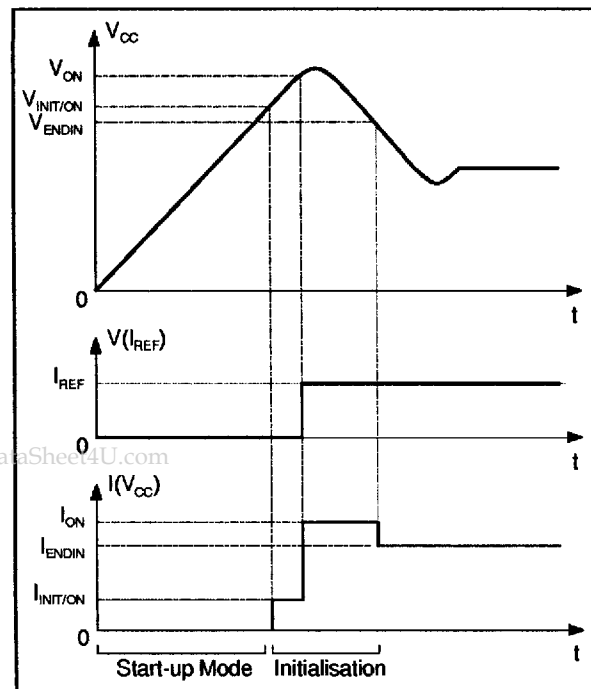
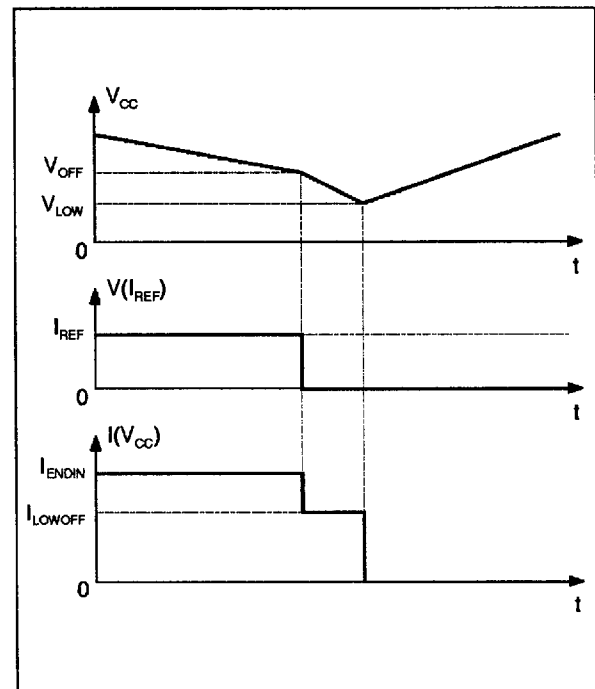

Figure 3 : IC from ON to OFF



ELECTRICAL CHARACTERISTICS (continued) ($T_{amb} = 25^{\circ}\text{C}$)

Symbol	Parameter	Test Conditions	Min.	Typ.	Max.	Unit
--------	-----------	-----------------	------	------	------	------

PERIODIC FUNCTIONS - OUTPUT CHARACTERISTICS (Figure 4)

($V_{CC} = 9\text{V}$, $V_{OVER} = 3\text{V}$, $V_{REGT} = V_{REGF} = 3\text{V}$, $V_{FMAX} = 1\text{V}$, $V_{SET\ DELAY} = 0.5\text{V}$, $I_{OUTH} = 200\text{mA}$, $I_{OUTL} = 200\text{mA}$, $R_{FMIN} = 18\text{k}\Omega$)

V_{DROPH}	Voltage Drop at OUT H	$I_{OUTH} = 200\text{mA}$		1.8	2.2	V
I_{OUTH}	Output H Current				+200	mA
V_{DROPL}	Voltage Drop at OUT L	$I_{OUTL} = -800\text{mA}$		1.5	2.3	V
I_{OUTL}	Output L Current		-800		+200	mA
R_{OUTH}	Rising Time of OUT H Signal				150	ns
F_{OUTH}	Falling Time of OUT H Signal				150	ns
R_{OUTL}	Rising Time of OUT L Signal				200	ns
F_{OUTL}	Falling Time of OUT L Signal				200	ns
T_{DHL}	Time Delay Between the Falling Times of OUT H and OUT L		90		150	ns
V_{zen}	Maximum Voltage on Pins OUT H and OUT L	$V_{CC} = 10\text{V to }13\text{V}$	6.9	7.4	8	V
T_{SET}	Forced SET Time		24	31	43	μs
T_{SETMAX}	Maximum SET Delay	$V_{SET\ DELAY} = 3\text{V}$		1.3		μs
F_{MINAB}	$\Delta(1/F_{min})$	For $R = 10\text{k}\Omega$ (Ra) and $R = 18\text{k}\Omega$ (Rc)		9		μs
F_{MINBC}	$\Delta(1/F_{min})$	For $R = 18\text{k}\Omega$ (Rb) and $R = 33\text{k}\Omega$ (Rc)		16		μs
ΔF_{MAX}	$\Delta(1/F_{max})$			14		μs
M_{INCT}	Minimal Conduction Time		350	450	600	ns
Control Characteristics for Primary Regulation (Figure 5)						
ΔV_{REG1}	ΔV_{REG}	At $V_{PR} = 0.5\text{V}$ and 2.5V	1.9	1.96	2.1	V
V_{REGPR1}	V_{REG} in Primary Regulation	At $V_{PR} = 3\text{V}$	3.9	4.1	4.3	V
ΔV_{REG2}	ΔV_{REG}	At $V_{PR} = 3.3\text{V}$ and 3.6V	1.1	1.35	1.6	V
V_{PROFF}	V_{PR} which Switches the IC Off		4.5			V
Control Characteristics for Secondary Regulation (Figure 6)						
ΔV_{RS1}	ΔV_{REG}	At $V_{SEC} = -1.2\text{V}$ and -2.5V	1.1	1.32	1.5	V
V_{RS28}	V_{REG}	At $V_{SEC} = -2.8\text{V}$	3.75	4	4.25	V
ΔV_{RS2}	ΔV_{REG}	At $V_{SEC} = -3.2\text{V}$ and -3.5V		1.25		V
V_{SECOFF}	V_{SEC} which Switches the IC Off				-4.5	V

Figure 4

Figure 5



4614C-06.EPS

Figure 6

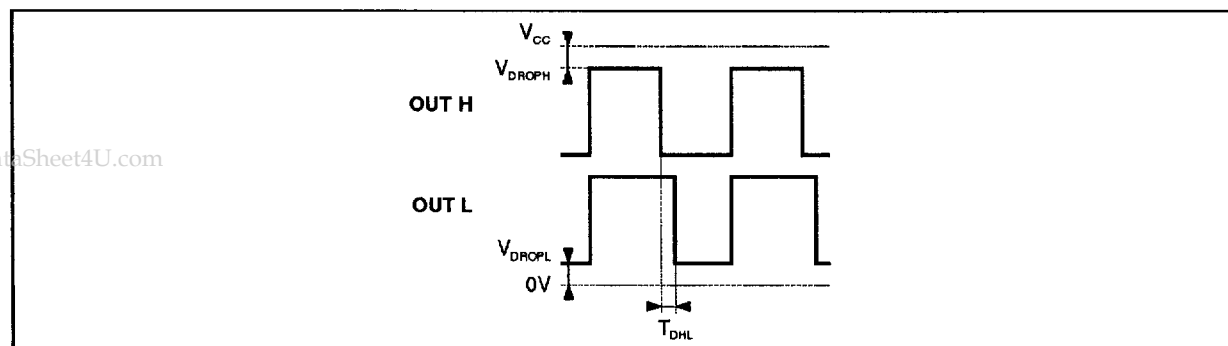
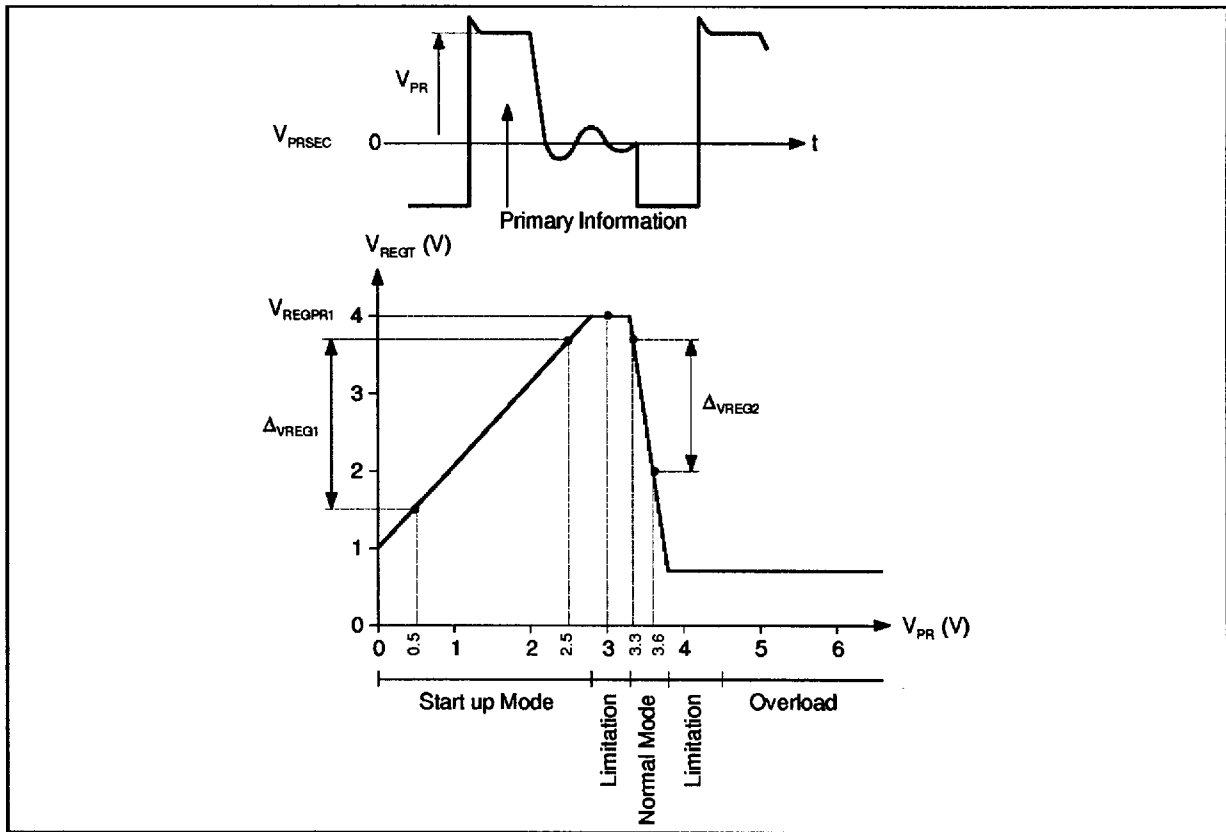
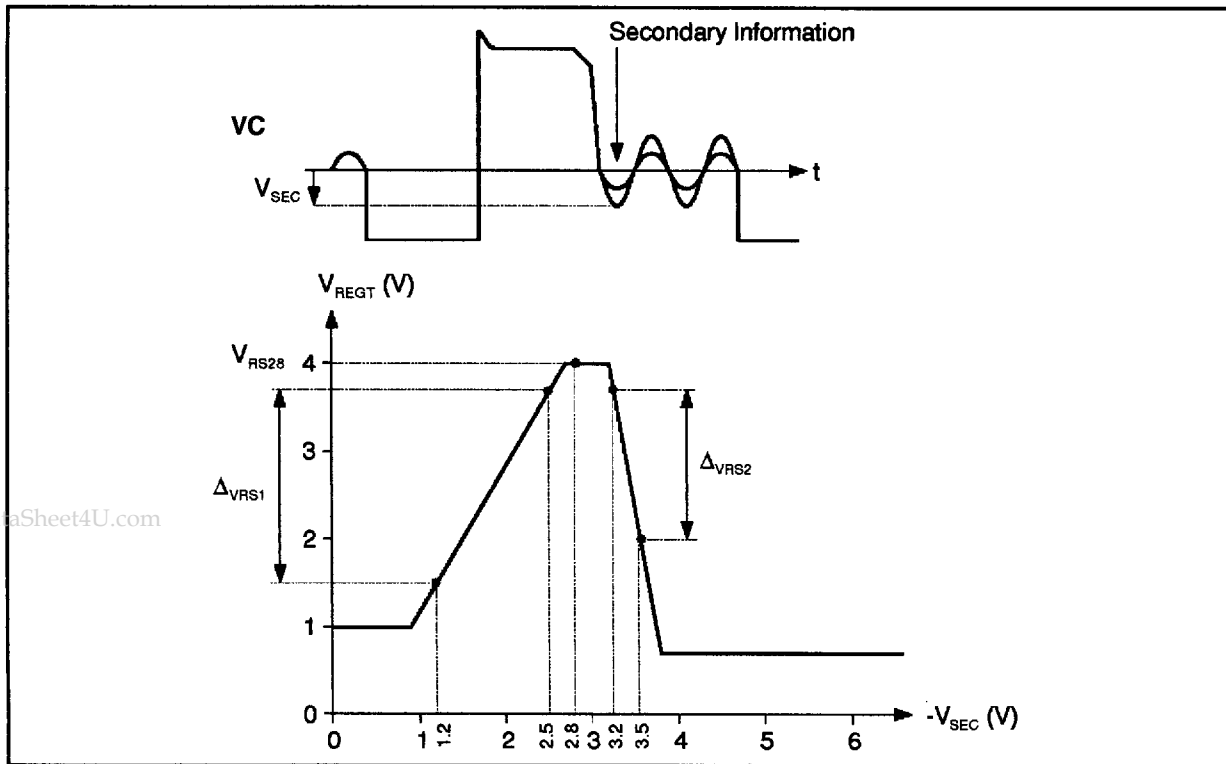

4614C-07.EPS

APPLICATION DIAGRAM

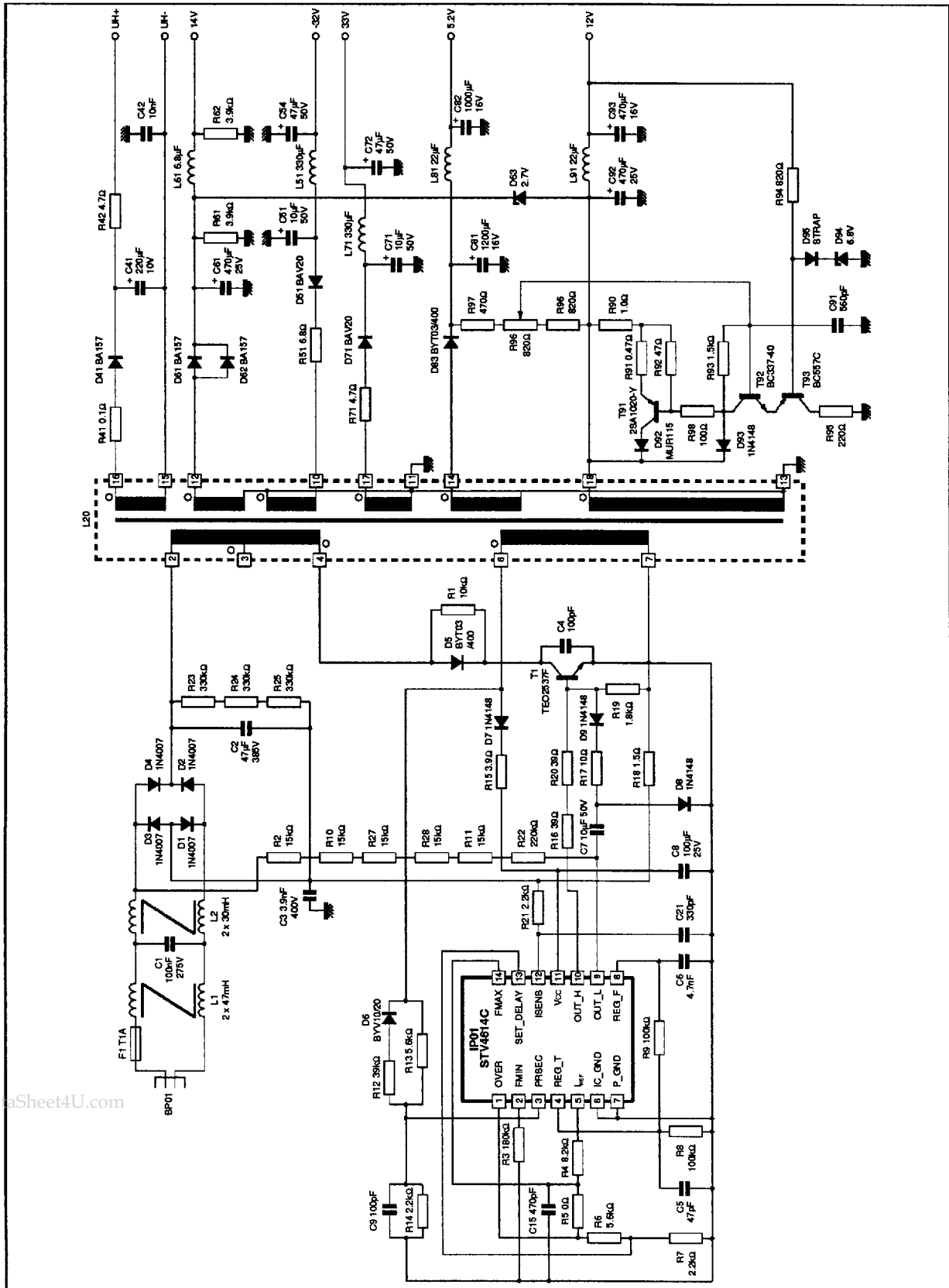

www.DataSheet4U.com

4614C-03.EPS

STV4614C

PACKAGE MECHANICAL DATA 14 PINS - PLASTIC PACKAGE

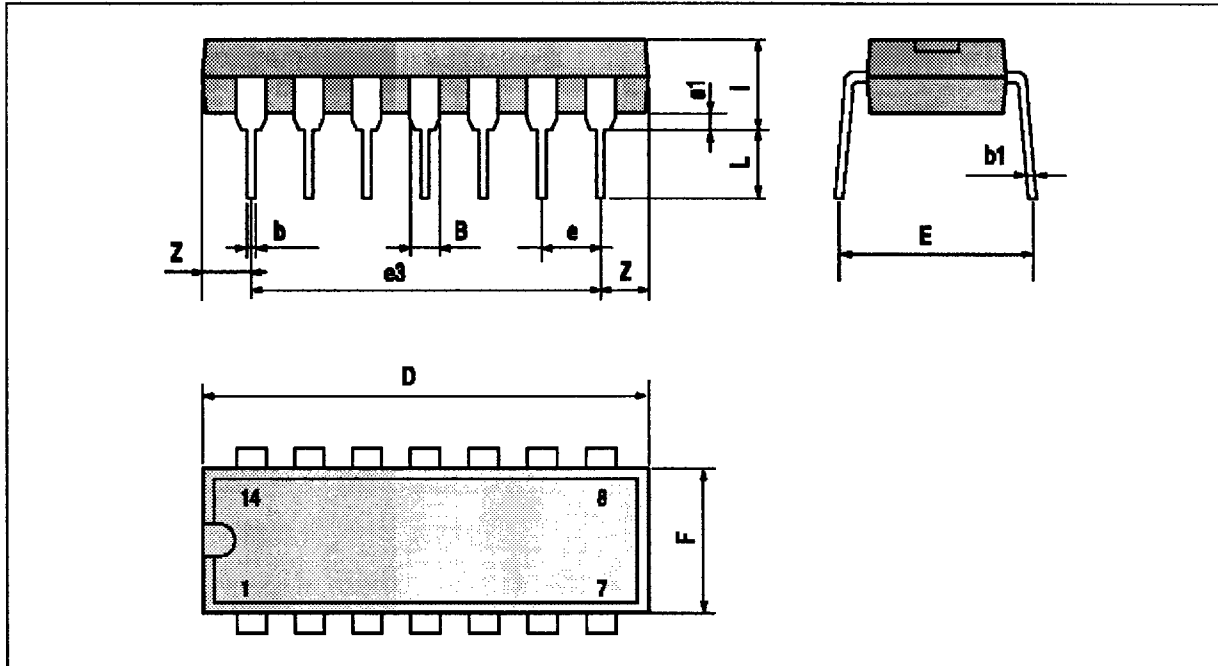

PM-DIP14.WMF

Dimensions	Millimeters			Inches		
	Min.	Typ.	Max.	Min.	Typ.	Max.
a_1	0.51			0.020		
B	1.39		1.65	0.055		0.065
b		0.5			0.020	
b_1		0.25			0.010	
D			20			0.787
E		8.5			0.335	
e		2.54			0.100	
e_3		15.24			0.600	
F			7.1			0.280
i			5.1			0.201
L		3.3			0.130	
Z	1.27		2.54	0.050		0.100

DIP14.TBL

Information furnished is believed to be accurate and reliable. However, SGS-THOMSON Microelectronics assumes no responsibility for the consequences of use of such information nor for any infringement of patents or other rights of third parties which may result from its use. No licence is granted by implication or otherwise under any patent or patent rights of SGS-THOMSON Microelectronics. Specifications mentioned in this publication are subject to change without notice. This publication supersedes and replaces all information previously supplied. SGS-THOMSON Microelectronics products are not authorized for use as critical components in life support devices or systems without express written approval of SGS-THOMSON Microelectronics.

www.DataSheet4U.com

© 1995 SGS-THOMSON Microelectronics - All Rights Reserved

Purchase of μ C Components of SGS-THOMSON Microelectronics, conveys a license under the Philips μ C Patent. Rights to use these components in a μ C system, is granted provided that the system conforms to the μ C Standard Specifications as defined by Philips.

SGS-THOMSON Microelectronics GROUP OF COMPANIES

Australia - Brazil - China - France - Germany - Hong Kong - Italy - Japan - Korea - Malaysia - Malta - Morocco
The Netherlands - Singapore - Spain - Sweden - Switzerland - Taiwan - Thailand - United Kingdom - U.S.A.