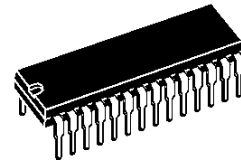

**MONOCHIP TELETEXT DECODER  
 WITH 8 INTEGRATED PAGES**

- COMPLETE TELETEXT DECODER INCLUDING AN 8 PAGE MEMORY ON A SINGLE CHIP
- UPWARD SOFTWARE COMPATIBLE WITH PREVIOUS SGS-THOMSON'S MULTICHIP SOLUTIONS (SAA5231, SDA5243, STV5345)
- SINGLE +5V SUPPLY VOLTAGE
- SINGLE 13.875MHz CRYSTAL
- REDUCED SET OF EXTERNAL COMPONENTS, NO EXTERNAL ADJUSTMENT
- OPTIMIZED NUMBER OF DIGITAL SIGNALS REDUCING EMC RADIATION
- HIGH DENSITY CMOS TECHNOLOGY
- DIGITAL DATA SLICER AND DISPLAY CLOCK PHASE LOCK LOOP
- 28 PIN DIP & SO PACKAGE

**DIP28**

(Plastic Package)

**ORDER CODE :**

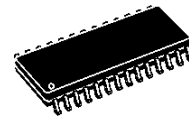
 STV5346 West European  
 STV5346/H East European  
 STV5346/T Turkish & European

**SO28**

(Plastic Package)

**ORDER CODE :**

 STV5346D West European  
 STV5346D/H East European  
 STV5346D/T Turkish & European

**DESCRIPTION**

The STV5346 decoder is a computer-controlled teletext device including an 8 page internal memory. Data slicing and capturing extracts the teletext information embedded in the composite video signal. Control is accomplished via a two wire serial I<sup>2</sup>C bus ®. Internal ROM provides a character set suitable to display text using up to seven national languages. Different ROM versions will support several national character sets. Hardware and software features allow selectable master/slave synchronization configurations. The STV5346 also supports facilities for reception and display of current level protocol data.

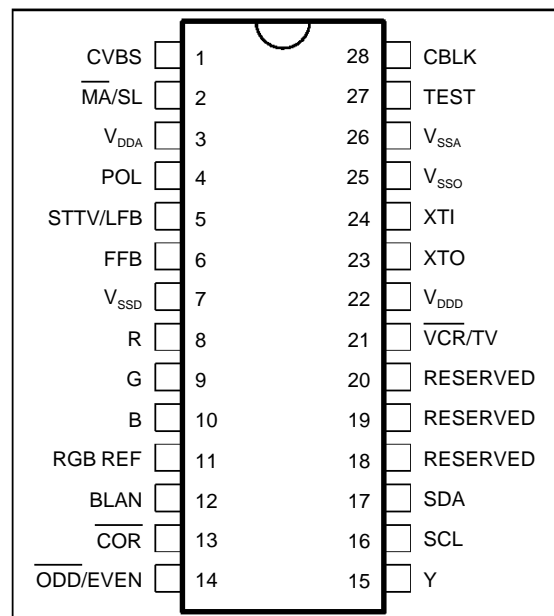
**PIN CONNECTIONS**

5346-01.EPS

# STV5346 - STV5346/H - STV5346/T

## PIN DESCRIPTION

Pin N°	Symbol	Function	Description
1	CVBS	Input	Composite Video Signal Input through Coupling Capacitor
2	MA/SL	Input	Master/Slave Selection Mode
3	V <sub>DDA</sub>	Analog Supply	+5V
4	POL	Input	STTV / LFB / FFB Polarity Selection
5	STTV/LFB	Output / Input	Composite Sync Output, Line Flyback Input
6	FFB	Input	Field Flyback Input
7	V <sub>SSD</sub>	Ground	Digital Ground
8	R	Output	Video Red Signal
9	G	Output	Video Green Signal
10	B	Output	Video Blue Signal
11	RGBREF	Supply	DC Voltage to Define RGB High Level
12	BLAN	Output	Fast Blanking Output TTL Level
13	COR	Output	Open Drain Contrast Reduction Output
14	ODD/EVEN	Output	25Hz Output Field Synchronized for Non-interlaced Display
15	Y	Output	Open Drain Foreground Information Output
16	SCL	Input	Serial Clock Input
17	SDA	Input/ Output	Serial Data Input/Output
18	RESERVED	Test Input/ Output	To be Connected to V <sub>SSD</sub> through a resistor
19	RESERVED	Test Input/ Output	To be Connected to V <sub>SSD</sub> through a resistor
20	RESERVED	Test Input/ Output	To be Connected to V <sub>SSD</sub> through a resistor
21	VCR/TV	Input	PLL Time Constant Selection
22	V <sub>DDD</sub>	Digital Supply	+5V
23	XTO	Crystal Output	Oscillator Output 13.875MHz
24	XTI	Crystal Input	Oscillator Input 13.875MHz
25	V <sub>SSO</sub>	Ground	Oscillator Ground
26	V <sub>SSA</sub>	Ground	Analog Ground
27	TEST	Test	Grounded to V <sub>SSA</sub>
28	CBLK	Input / Output	To connect Black Level Storage Capacitor

5346-01.TBL

## BLOCK DIAGRAM

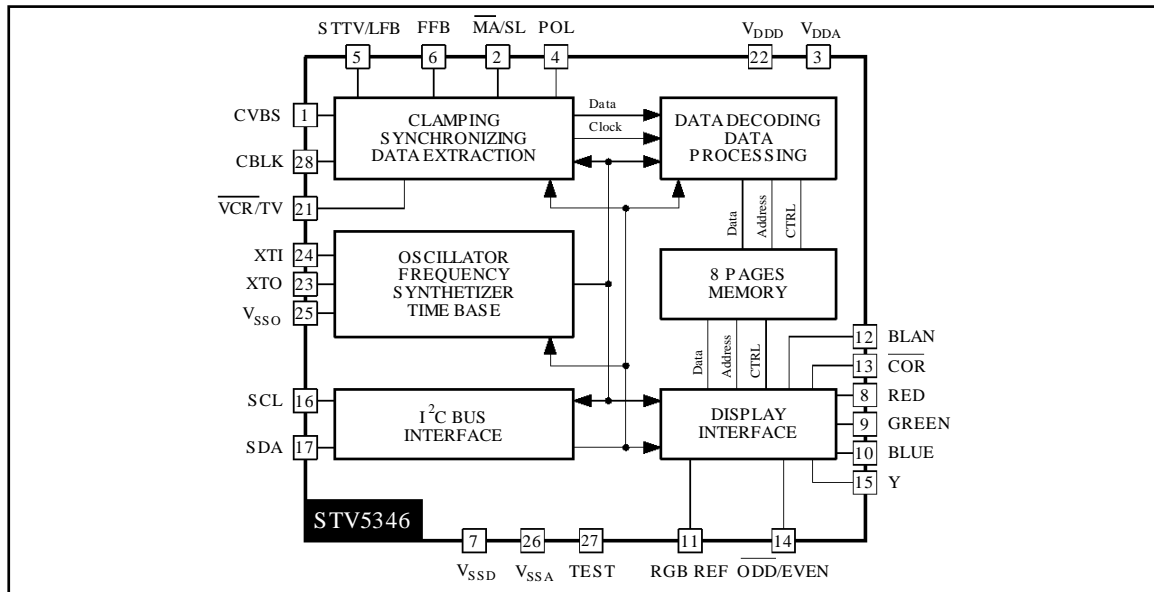

5346-02.EPS

## ABSOLUTE MAXIMUM RATINGS

Symbol	Parameter	Value	Unit
V <sub>DD</sub>	Positive Supply Voltage on V <sub>DDD</sub> and V <sub>DDA</sub>	- 0.3, 6.0	V
V <sub>I</sub>	Input Voltage (any input)	- 0.3, V <sub>DD</sub> + 0.5	V
V <sub>O</sub>	Output Voltage (any output)	- 0.3, V <sub>DD</sub> + 0.5	V
ΔV <sub>DD</sub>	Difference between V <sub>DDD</sub> , V <sub>DDA</sub>	0.25	V
T <sub>oper</sub>	Operating Ambient Temperature	0, + 70	°C
T <sub>stg</sub>	Storage Temperature	- 40, + 150	°C

5346-02.TBL

ELECTRICAL CHARACTERISTICS (V<sub>DD</sub> = 5V, V<sub>SS</sub> = 0V, T<sub>A</sub> = 25°C)

Symbol	Parameter	Min.	Typ.	Max.	Unit
--------	-----------	------	------	------	------

## SUPPLIES

V <sub>DD</sub>	Supply Voltage	4.75	5	5.25	V
I <sub>DDD</sub>	V <sub>DDD</sub> Pin Supply Current		30		mA
I <sub>DDA</sub>	V <sub>DDA</sub> Pin Supply Current		5		mA

## INPUTS

CBLK					
I <sub>BLKO</sub>	Source Current (V <sub>CBLK</sub> = 2V, V <sub>CVBS</sub> = 0V)		80		μA
I <sub>BLKI</sub>	Sink Current (V <sub>CBLK</sub> = 2V, V <sub>CVBS</sub> = 1V)		- 10		μA
CVBS					
CVBSI	Video Input Amplitude (peak to peak)		1		V
CVBSC	Input Capacitance			10	pF
t <sub>SYNC</sub>	Delay from CVBS to TCS Output from STTV Pin		200		ns
V <sub>CLAMP</sub>	Clamping Level at Synchro Pulse		0		mV
I <sub>CLPH</sub>	High Level Clamp Current (CVBS = V <sub>CLAMP</sub> + 1V)		5		μA
I <sub>CLPL</sub>	Low Level Clamp Current (CVBS = V <sub>CLAMP</sub> - 0.3V)		- 400		μA
MA/SL, POL, LFB, FFB, VCR/TV					
V <sub>IL</sub>	Input Voltage Low Level	- 0.3		+ 0.8	V
V <sub>IH</sub>	Input Voltage High Level	2		V <sub>DD</sub>	V
I <sub>IL</sub>	Input Leakage Current (V <sub>I</sub> = 0 to V <sub>DD</sub> )	- 10		+ 10	μA
C <sub>I</sub>	Input Capacitance			10	pF
SCL, SDA					
V <sub>IL</sub>	Input Voltage Low Level	- 0.3		+ 1.5	V
V <sub>IH</sub>	Input Voltage High Level	3		V <sub>DD</sub>	V
I <sub>IL</sub>	Input Leakage Current (V <sub>I</sub> = 0 to V <sub>DD</sub> )	- 10		+ 10	μA
f <sub>SCL</sub>	Clock Frequency (SCL)			100	kHz
t <sub>R</sub> , t <sub>F</sub>	Input Rise and Fall Time (10 to 90%)			2	μs
C <sub>I</sub>	Input Capacitance			10	pF
RGB REF					
V <sub>I</sub>	Input Voltage	- 0.3		V <sub>DD</sub>	V
I <sub>I</sub>	Input Current			50	mA

5346-03.TBL

## STV5346 - STV5346/H - STV5346/T

### ELECTRICAL CHARACTERISTICS - $V_{DD} = 5V$ , $V_{SS} = 0V$ , $T_A = 25^\circ C$ (continued)

Symbol	Parameter	Min.	Typ.	Max.	Unit
--------	-----------	------	------	------	------

#### OUTPUTS

RGB					
$V_{OL}$	Output Low Voltage ( $I_{OL} = 2mA$ )			0.4	V
$V_{OH}$	Output High Voltage ( $I_{OH} = -2mA$ , RGB REF = $V_{DD}/2$ )	RGB REF - 0.5		RGB REF	V
$C_L$	Load Capacitance			50	pF
$t_R, t_F$	Rise and Fall Time (10 to 90%)			20	ns
BLAN					
$V_{OL}$	Output Low Voltage ( $I_{OL} = 2mA$ )	0		0.4	V
$V_{OH}$	Output High Voltage ( $I_{OH} = -0.2mA$ )	$V_{DD} - 0.5$			V
$C_L$	Load Capacitance			50	pF
$t_R, t_F$	Rise and Fall Time (10 to 90%)			20	ns
ODD/EVEN, STTV					
$V_{OL}$	Output Low Voltage ( $I_{OL} = 2mA$ )	0		0.5	V
$V_{OH}$	Output High Voltage ( $I_{OH} = -0.2mA$ )	$V_{DD} - 0.8$		$V_{DD}$	V
$C_L$	Load Capacitance			50	pF
$t_R, t_F$	Rise and Fall Time (10 to 90%)			20	ns
COR AND Y (with Pull up to $V_{DDD}$ )					
$V_{OL}$	Output Low Voltage ( $I_{OL} = 2mA$ )	0		0.5	V
$C_L$	Load Capacitance			25	pF
$t_F$	Fall Time ( $R_L = 1.2k\Omega$ , $V_{DDD} = 0.5V$ to $1.5V$ )			50	ns
$I_{OLL}$	Output Leakage Current	-10		+10	$\mu A$
SDA					
$V_{OL}$	Output Low Voltage ( $I_{OL} = 3mA$ )	0		0.5	V
$t_F$	Fall Time (3.0 to 1.0V)			200	ns
$C_L$	Load Capacitance			400	pF

#### CRYSTAL OSCILLATOR

XTI, XTO					
$f_{XTAL}$	Crystal Frequency		13.875		MHz
$R_{BIAS}$	Internal Bias Resistance	0.4	1	3	$M\Omega$
$C_i$	Input Capacitance			7	pF

#### TIMING

SERIAL BUS (referred to $V_{IH} = 3V$ , $V_{IL} = 1.5V$ )					
$t_{LOW}$ $t_{HIGH}$	Clock : ● Low Period ● High Period	4 4			$\mu s$
$t_{SU, DAT}$	Data Set-up Time	250			ns
$t_{HD, DAT}$	Data Hold Time	170			ns
$t_{SU, STO}$	Stop Set-up Time from Clock High	4			$\mu s$
$t_{BUF}$	Start Set-up Time following a Stop	4			$\mu s$
$t_{HD, STA}$	Start Hold Time	4			$\mu s$
$t_{SU, STA}$	Start Set-up Time following Clock Low to High Transition	4			$\mu s$

5346-04.TBL

Figure 1 : Display Output Timing

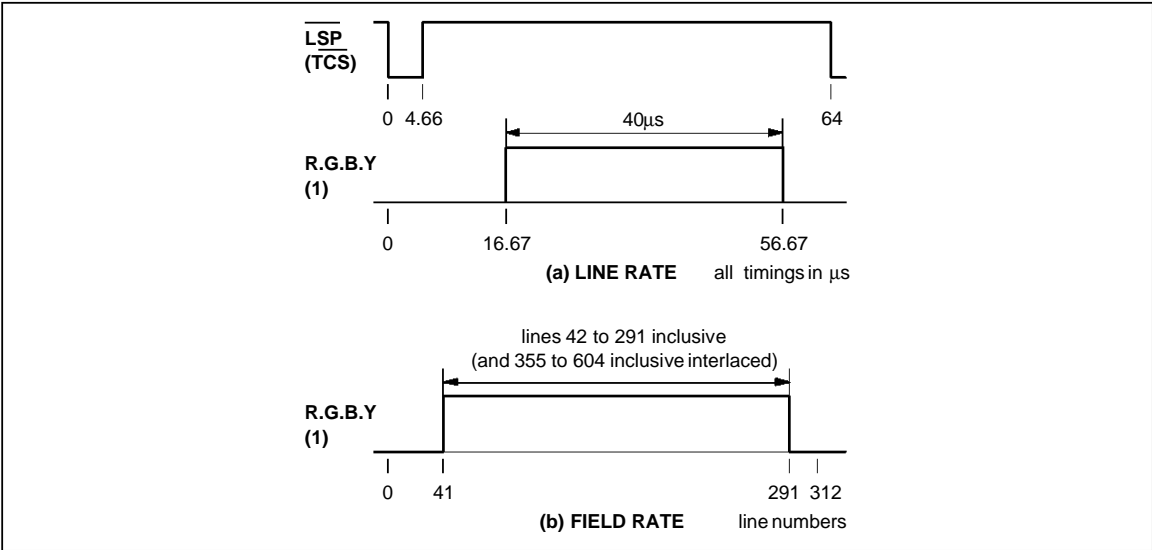

5346-03.EPS

Figure 2 : Serial Bus Timing

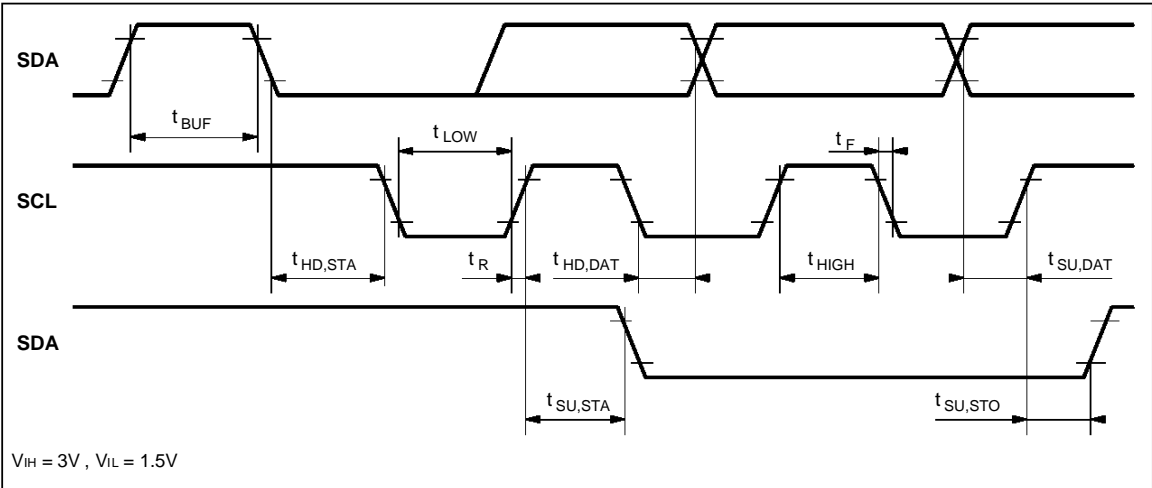

5346-04.EPS

Figure 3 : Master Synchronization Mode - Hardware Configuration

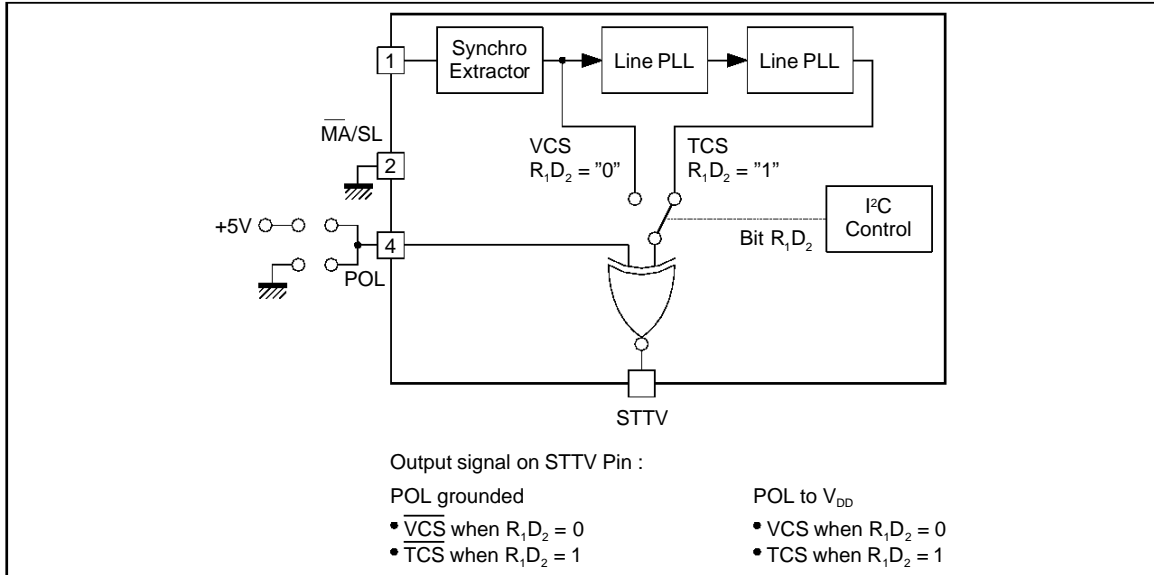

5346-05.EPS

Figure 4 : Master Synchronization Mode - Delivered Composite Synchronization Signal

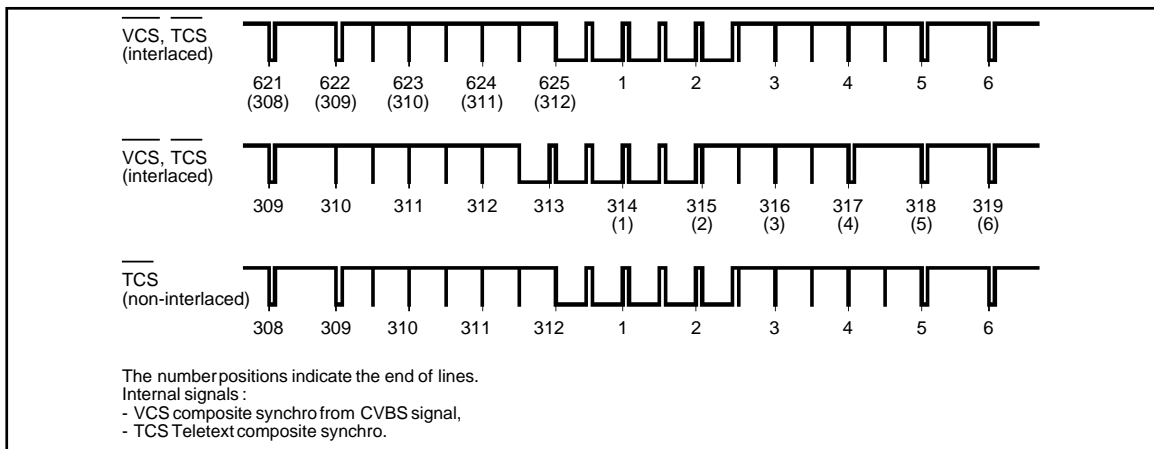

5346-06.EPS

Figure 5 : Slave Synchronization Mode

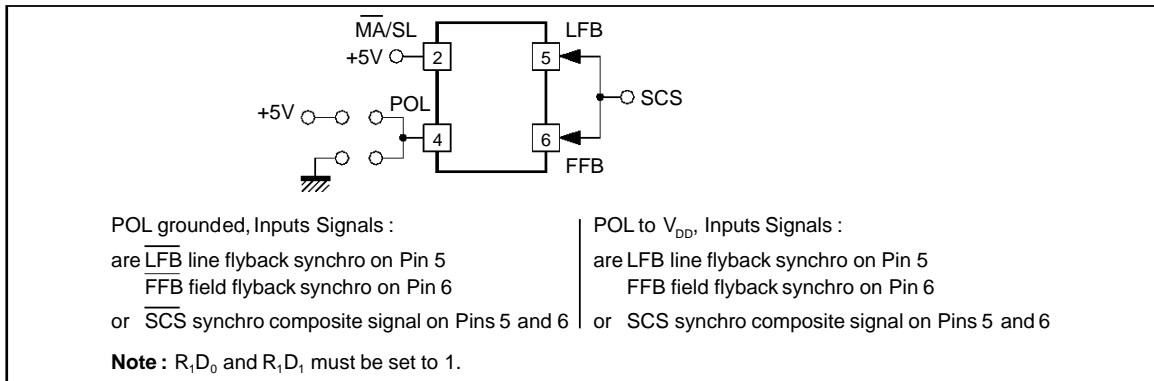

5346-07.EPS

APPLICATION DIAGRAM

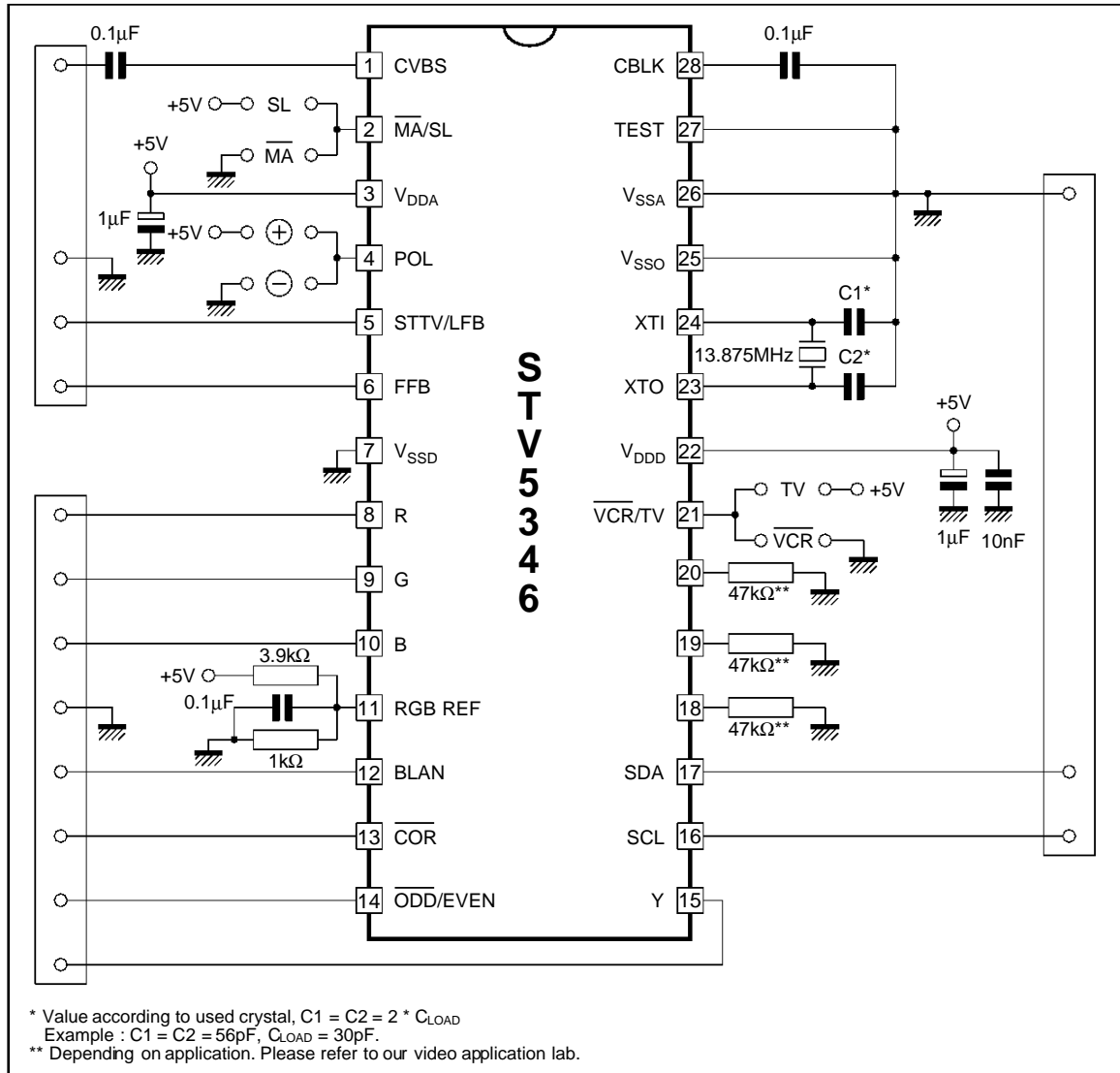

Remark : all the power supply inputs must be switched on at the same time (connected to the same source).

**FUNCTIONAL DESCRIPTION**

**I - Displayable Page Memory Map**

The organization of a page-memory is shown in Figure 6.

The display area consists of 25 rows of 40 characters per row.

The organization is as follows :

- Row zero contains the page header :
  - The first seven characters (0 - 6) are used for messages regarding the operational status.
  - The eighth character is an alphanumeric control character either "white" or "green" defining the "search" status of the page. When it is "white" the operational state is normal and the header appears white ; when it is "green" the opera-

tional state corresponds to the "search mode" and the header appears green.

- The following twenty-four characters give the header of the requested page when the system is in search mode.
  - The last eight characters display the time of day.
- Row number twenty-four is used by the microprocessor for the display of information, or used to display X/24 colored key data according to R0D7 bit.
  - Row twenty-five comprises ten bytes of control data concerning the received page (see Table 1) and fourteen free bytes which can be used by the microprocessor.

**Figure 6 : Page Memory Organization**

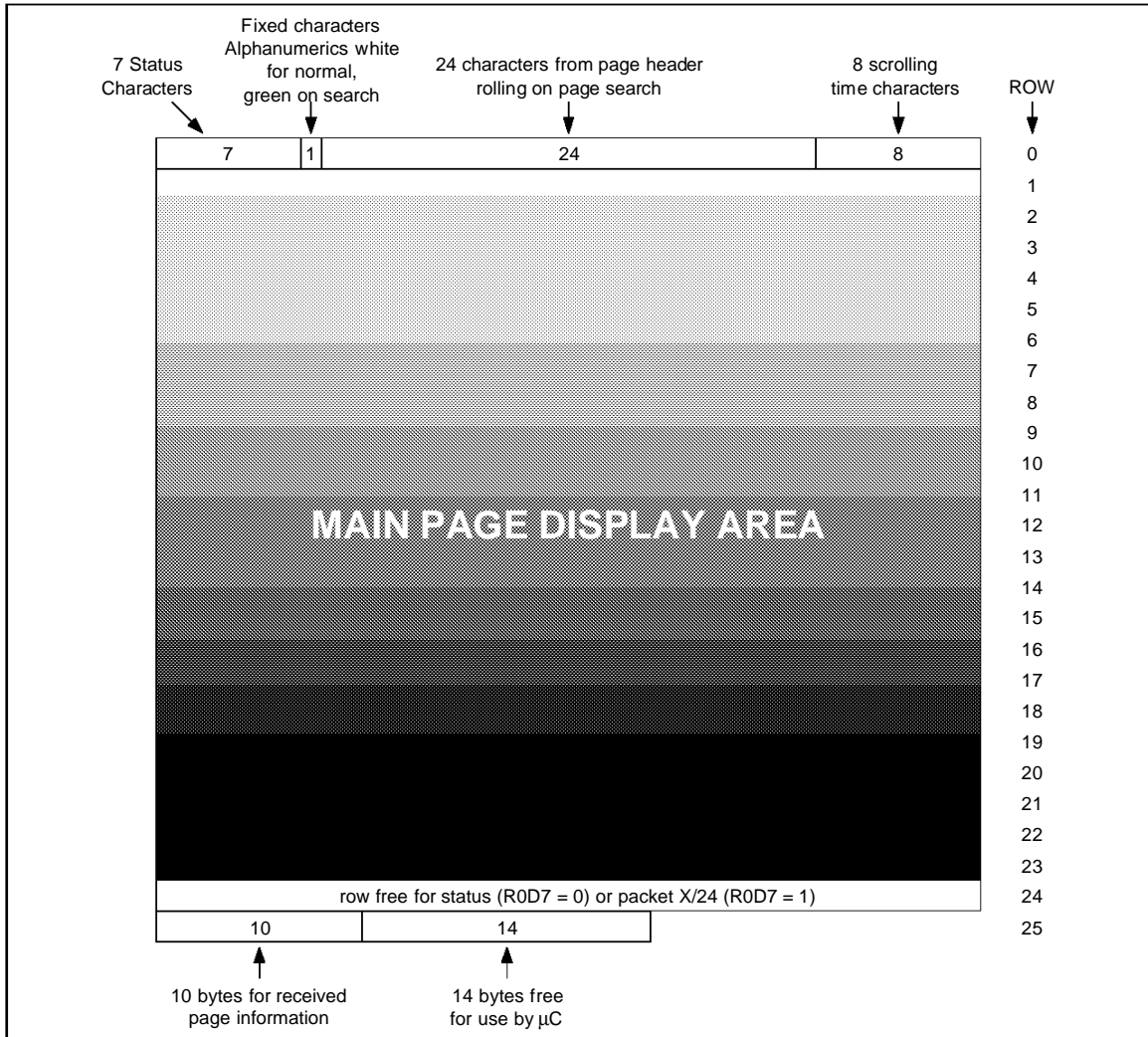



**FUNCTIONAL DESCRIPTION** (continued)  
**II - Ghost Row Memory Map**

Row Address of Stored Data	Designation Code	Row (Packet) Number	Function	
0	0 0 0 0	X / 26	Enhanced display facilities	
1	0 0 0 1			
2	0 0 1 0			
3	0 0 1 1			
4	0 1 0 0			
5	0 1 0 1			
6	0 1 1 0			
7	0 1 1 1			
8	1 0 0 0			
9	1 0 0 1			
10	1 0 1 0			
11	1 0 1 1			
12	1 1 0 0			
13	1 1 0 1			
14	1 1 1 0			
15	0 0 1 0	X / 28	Conditional access	
16	0 0 0 0	X / 27	Editorial	Linked pages
17	0 0 0 1		Composition	
18	0 1 0 0			
19	0 1 0 1			
20		X / 24	Page extension stored here if R0D7 = 0	
21		X / 25	Page extension	
22	0 0 0 0	X / 28	Color definition	
23	X X X X	8 / 30 *	* Broadcasting service data packet	
24	0 0 0 1	X/28	Character set designation	
25	Not used			

Page related data stored in chapter corresponding to level 1 data,  
i.e. For 0 goes in 4  
" 1 " " 5  
" 2 " " 6  
" 3 " " 7

5346-05.TBL

\* Packet 8/30 storage : 8/30/0,1 : chapter 4, row23  
8/30/2,3 : chapter 5, row23  
8/30/4 to 15 : chapter 6, row23

**Table 1 : Row 25 Received Page Control Data Format**

D0	PU0	PT0	MU0	MT0	HU0	HT0	C7	C11	MAG0	0
D1	PU1	PT1	MU1	MT1	HU1	HT1	C8	C12	MAG1	0
D2	PU2	PT2	MU2	MT2	HU2	C5	C9	C13	MAG2	0
D3	PU3	PT3	MU3	C4	HU3	C6	C10	C14	0	0
D4	HAM	HAM	HAM	HAM	HAM	HAM	HAM	HAM	FOUND	0
D5	0	0	0	0	0	0	0	0	0	PBLF
D6	0	0	0	0	0	0	0	0	0	0
D7	0	0	0	0	0	0	0	0	0	0
COLUMN	0	1	2	3	4	5	6	7	8	9

Page number : - MAG = magazine, PU = page units, PT = page tens.  
Page sub-code : - MU = minutes units, MT = minutes tens, HU = hours units, HT = hours tens.  
PBLF = page being looked for, FOUND = low for page found, HAM = hamming error in byte, C4-14 = control bits.

5346-06.TBL

**FUNCTIONAL DESCRIPTION** (continued)

**III - I<sup>2</sup>C Bus Register Map** (see Table 2)

Registers R0 to R10 are write only whilst R11A is a read/write and R11B is a read only register respect to the microprocessor.

The automatic succession on a byte basis is indicated by the arrows in Table 2.

In the normal operating mode TB should be set to logic level 0.

After power-up the contents of the registers are as

follows : all bits in registers R0 to R11A are cleared to zero with the exception of bits D0 and D1 in registers R5 and R6 which are set to logical one.

After power-up all the memory bytes are preset to hexadecimal value 20H (space) with the exception of the byte corresponding to row 0 of column 7 of chapter 0 which is set to the value corresponding to "alpha white" hexadecimal value 07H.

**Table 2 : Register specification**

D7	D6	D5	D4	D3	D2	D1	D0	
X24 POSITION	FREE RUNNING PLL	(1)	DISABLE ROLLING HEADER	(1)	EVEN OFF	(1)	SEL 11B	R0 Mode 0
(1)	7 + P/ 8 BIT	ACQ. ON/OFF	GHOST ROW ENABLE	DEW/ FULL FIELD	TCS ON	T1	T0	R1 Mode 1
(1)	BANK SELECT A2	ACQ. CCT A1	ACQ. CCT A0	TB	START COLUMN SC2	START COLUMN SC1	START COLUMN SC0	R2 Page request address
(1)	(1)	(1)	PRD4	PRD3	PRD2	PRD1	PRD0	R3 Page request data
(1)	(1)	(1)	(1)	(1)	A2	A1	A0	R4 Display chapter
BKGND OUT	BKGND IN	COR OUT	COR IN	TEXT OUT	TEXT IN	PON OUT	PON IN	R5 Display control (normal)
BKGND OUT	BKGND IN	COR OUT	COR IN	TEXT OUT	TEXT IN	PON OUT	PON IN	R6 Display control (newsflash / subtitle)
STATUS ROW BTM/TOP	CURSOR ON/OFF	CONCEAL/ REVEAL	TOP/ BOTTOM	SINGLE/ DOUBLE HEIGHT	BOX ON 24	BOX ON 1-23	BOX ON 0	R7 Display mode
(1)	(1)	(1)	(1)	CLEAR MEM.	A2	A1	A0	R8 Active chapter
(1)	(1)	(1)	R4	R3	R2	R1	R0	R9 Active row
(1)	(1)	C5	C4	C3	C2	C1	C0	R10 Active column
D7 (R/W)	D6 (R/W)	D5 (R/W)	D4 (R/W)	D3 (R/W)	D2 (R/W)	D1 (R/W)	D0 (R/W)	R11A Active data
60Hz	0	0	0	0	0	0	V <sub>CS</sub> QUAL	R11B Status

(1) Reserved register bits : must be set to 0

5346-07.TBL

FUNCTIONAL DESCRIPTION (continued)

III - I<sup>2</sup>C Bus Register Map (continued)

III.1 - Register Functions

Register	Function	Bit(s)	Description
R0 Address 00H	R11 addressing and pin functions control	SEL 11B (D0)	Selection of register 11B (D0 = 1) or 11A (D0 = 0)
		EVEN OFF (D2)	Control of $\overline{\text{ODD}}$ /EVEN pin : EVEN signal output (D2 = 0) or grounded (D2 = 1)
		DISABLE ROLLING HEADER	D4 = 1, Disable rolling header D4 = 0, Normal operation
		FREE RUNNING PLL (D6)	D6 = 0, PLL locks on line frequency D6 = 1, to force free running mode
		X/24 POSITION (D7)	D7 = 0, packet X/24 stored to chapter 4 to 7/row 20 D7 = 1, packet X/24 stored to chapter 0 to 3/row 24
R1 Address 01H	Operating mode controls	T1 (D1)    T0 (D0) 0            0 0            1 1            0 1            1	Character display line control : 312/313 line MIX - mode with interlace 312/313 line TEXT - mode without interlace 312/312 line Terminal mode without interlace External synchronization. SCS mode (scan field synchro)
		TCS ON (D2)	Master Mode ( $\overline{\text{MA/SL}}$ Pin 2 = 0) case POL Pin 4 = 0 D2 = 0, Pin 5 = $\overline{\text{VCS}}$ D2 = 1, Pin 5 = TCS Slave Mode ( $\overline{\text{MA/SL}}$ Pin 2 = $V_{\text{DD}}$ ) No effect
		$\overline{\text{DEW}}$ / FULLFIELD (D3)	Selection of field flyback mode or full channel mode (D3 = 1) for recovering of Teletext data.
		GHOST ROW ENABLE (D4)	Selection of ghost row mode (D4 = 1)
		$\overline{\text{ACQUISITION}}$ ON / OFF (D5)	Control of acquisition operation (D5 = 0 enables acquisition)
		7 bits + parity or 8 bits without parity (D6)	Selection of received data format either 7 bits with parity (D6 = 0) or 8 bits without parity (D6 = 1).
		R2 Address 02H	Addressing information for a page request
TB (D3)	Test bit equal to "0" in the normal working mode.		
A0, A1 (D4, D5)	Address a group of four consecutive pages currently used for data acquisition.		
A2 (D6)	Address of one of the two groups of four pages for acquisition in normal mode.		
R3 Address 03H	Data relative to the requested page (see Table 3)	PRD0 - PRD4 (D0 - D4)	Written data in the page request RAM, starting with the columns addressed by SC0, SC1, SC2.
R4 Address 04H	Selection of one of eight pages to display	A0, A1, A2 (D0, D1, D2)	These 3 bits correspond to the logical states of the 3 address lines (A10, A11, A12) during memory read cycles.
R5 Address 05H	Display control for normal operation	PON (D0, D1)	Picture on (IN: D0, OUT: D1)
		TEXT (D2, D3)	Text on (IN: D2, OUT: D3)
		$\overline{\text{COR}}$ (D4, D5)	Contrast reduction on (IN: D4, OUT: D5)
		BKGND (D6, D7)	Background color on (IN: D6, OUT: D7)
		IN / OUT	Enable inside/outside the box
R6 Address 06H	Display control for news-flash subtitle generation	See R5	See R5

5346-08.TBL

**FUNCTIONAL DESCRIPTION** (continued)

**III - I<sup>2</sup>C Bus Register Map** (continued)

**III.1 - Register Functions** (continued)

Register	Function	Bit(s)	Description
R7 Address 07H	Display mode	BOX ON 0, 1-23,24 (D0, D1, D2)	The "boxing" function is enabled on row 0,1-23 and 24 by D0, D1 and D2 set to one.
		$\overline{\text{TOP}}$ / BOTTOM Single / Double Height (D4/D3)	X0 = Normal 01 = double height Rows 0 to 11 11 = double height Rows 12 to 23
		$\overline{\text{Conceal}}$ / Reveal (D5)	Conceal Reveal Function
		Cursor ON/ $\overline{\text{OFF}}$ (D6)	Cursor position given by row/column value of R9/R10
		$\overline{\text{STATUS ROW}}$ BTM / TOP (D7)	The row 24 is displayed before the "Main text Area" (lines 0-23) or after (D7 = 0).
R8 to R11A Address 08H to 0BH*	Active chapter address (R8), active row address (R9), active column address (R10). Data contained in R11A read (written) from (to) memory by microprocessor via I <sup>2</sup> C.		
R11B Address 0BH*	Status	VCS QUAL (D0)	Good VCS quality signal detected (D0 = 1) or disturbance (D0 = 0)
		60Hz (D7)	VCS received with 60Hz frequency (D7 = 1) or 50Hz (D7 = 0). Valid only when if good V <sub>CS</sub> (D0 = 1)

\* Reading of R11A or R11B is determined by register 0, bit D0. Nevertheless, write operation is always performed on R11A register.

**Table 3 : Register R3**

START COLUMN	PRD4	PRD3	PRD2	PRD1	PRD0
0	Do care magazine	$\overline{\text{HOLD}}$	MAG2	MAG1	MAG0
1	Do care page tens	PT3	PT2	PT1	PT0
2	Do care page units	PU3	PU2	PU1	PU0
3	Do care hours tens	X	X	HT1	HT0
4	Do care hours units	HU3	HU2	HU1	HU0
5	Do care minutes tens	X	MT2	MT1	MT0
6	Do care minutes units	MU3	MU2	MU1	MU0

The abbreviations have the same significance as in Table 1 with the exception of the "DO CARE" entries. It is only when this bit is "1" that the corresponding digit is taken into consideration on page request. For example, a page defined as "normal" or one defined as "timed" may be selected.

If " $\overline{\text{HOLD}}$ " is low the page is held. The addressing of successive bytes via the I<sup>2</sup>C is automatic.

**IV - Character Sets**

The complete character set with 8-bit decoding is given in Tables 4, 5 and 6.

Characters in columns 0 and 1 are normally displayed as blanks. Black dots represent the character shape whereas white dots represent the background.

Each character can be identified by a pair of corre-

sponding row and column integers : for example the character "3" may be indicated by 3/3.

A rectangle may be represented as follows :

The characters 8/6, 8/7, 9/5, 9/7 are used as special characters, always in conjunction with 8/5.

The 13 national characters are placed in columns with bit 8 = 0.

FUNCTIONAL DESCRIPTION (continued)

Table 4 : STV5346 Complete Character Set (with 8 bit codes) - West European Languages

b <sub>7</sub> b <sub>6</sub> b <sub>5</sub> b <sub>4</sub> b <sub>3</sub> b <sub>2</sub> b <sub>1</sub> b <sub>0</sub>	column	0	1	2	3	4	5	6	7	8	9	12	13	14	15
0 0 0 0	0	alphanumerics black	graphics black			S	P	°							
0 0 0 1	1	alphanumerics red	graphics red	!	1	A	Q	a	q	—	—	—	—	i	i
0 0 1 0	2	alphanumerics green	graphics green	”	2	B	R	b	r	#	#	#	#	ü	ü
0 0 1 1	3	alphanumerics yellow	graphics yellow	#	3	C	S	c	s	\$	\$	\$	\$	ÿ	ÿ
0 1 0 0	4	alphanumerics blue	graphics blue	%	4	D	T	d	t	%	%	%	%	z	z
0 1 0 1	5	alphanumerics magenta	graphics magenta	&	5	E	U	e	u	&	&	&	&	z	z
0 1 1 0	6	alphanumerics cyan	graphics cyan	'	6	F	V	f	v	'	'	'	'	z	z
0 1 1 1	7	alphanumerics white	graphics white	(	7	G	W	g	w	(	(	(	(	z	z
1 0 0 0	8	flash	conceal display	)	8	H	X	h	x	)	)	)	)	z	z
1 0 0 1	9	steady	continuous graphics	*	9	I	Y	i	y	*	*	*	*	z	z
1 0 1 0	10	end box	separated graphics	+	10	J	Z	j	z	+	+	+	+	z	z
1 0 1 1	11	start box	ESC	,	11	K	a	k	a	,	,	,	,	z	z
1 1 0 0	12	normal height	black background	-	12	L	o	l	o	-	-	-	-	z	z
1 1 0 1	13	double height	new background	.	13	M	ü	m	ü	.	.	.	.	z	z
1 1 1 0	14	SO	hold graphics	/	14	N	o	n	o	/	/	/	/	z	z
1 1 1 1	15	SI	release graphics	/	15	O		o		/	/	/	/	z	z

Case using C12 C13 C14 = 001 (German Set)

\* These control characters are reserved for compatibility with other data codes.  
 \*\* These control characters are presumed before each row begins

5346-10.EPS

FUNCTIONAL DESCRIPTION (continued)

Table 5 : STV5346/H Complete Character Set (with 8 bit codes) - East European Languages

B	T	S	b <sub>7</sub>	b <sub>6</sub>	b <sub>5</sub>	b <sub>4</sub>	b <sub>3</sub>	b <sub>2</sub>	b <sub>1</sub>	column	1	2	3	3a	4	5	6	6a	7	7a	8	9	12	13	14	15	
0	0	0	0	0	0	0	0	0	0	0	graphics black																
0	0	0	0	0	0	0	0	0	0	1	alphanumerics black	!	"	#	€	%	&	'	(	)	*	+	,	-	.	/	
0	0	0	0	0	0	0	0	0	0	1	alphanumerics red																
0	0	0	0	0	0	0	0	0	0	2	alphanumerics green																
0	0	0	0	0	0	0	0	0	0	3	alphanumerics yellow																
0	0	0	0	0	0	0	0	0	0	4	alphanumerics blue																
0	0	0	0	0	0	0	0	0	0	5	alphanumerics magenta																
0	0	0	0	0	0	0	0	0	0	6	alphanumerics cyan																
0	0	1	1	1	1	1	1	1	1	7	alphanumerics white																
1	0	0	0	0	0	0	0	0	0	8	flash																
1	0	0	0	1	0	0	0	0	0	9	steady																
1	0	0	0	0	0	0	0	0	0	10	end box																
1	0	1	1	1	1	1	1	1	1	11	start box																
1	1	0	0	0	0	0	0	0	0	12	normal height																
1	1	0	0	1	0	1	0	1	0	13	double height																
1	1	1	0	1	0	1	0	1	0	14	SO																
1	1	1	1	1	1	1	1	1	1	15	SI																

Case using C12 C13 C14 = 001 (Rumanian Set)

\* These control characters are reserved for compatibility with other data codes.  
 \*\* These control characters are presumed before each row begins

5346-11.EPS

FUNCTIONAL DESCRIPTION (continued)

Table 6 : STV5346/T Complete Character Set (with 8 bit codes) - Turkish European Languages

Bit	b <sub>7</sub>	b <sub>6</sub>	b <sub>5</sub>	b <sub>4</sub>	b <sub>3</sub>	b <sub>2</sub>	b <sub>1</sub>	0	1	2	2a	3	3a	4	5	6	6a	7	7a	8	9	12	13	14	15
B	↑	↑	↑	↑	↑	↑	↑	↑	↑	↑	↑	↑	↑	↑	↑	↑	↑	↑	↑	↑	↑	↑	↑	↑	↑
I	↑	↑	↑	↑	↑	↑	↑	↑	↑	↑	↑	↑	↑	↑	↑	↑	↑	↑	↑	↑	↑	↑	↑	↑	↑
T	↑	↑	↑	↑	↑	↑	↑	↑	↑	↑	↑	↑	↑	↑	↑	↑	↑	↑	↑	↑	↑	↑	↑	↑	↑
S	↑	↑	↑	↑	↑	↑	↑	↑	↑	↑	↑	↑	↑	↑	↑	↑	↑	↑	↑	↑	↑	↑	↑	↑	↑
b <sub>4</sub>	↑	↑	↑	↑	↑	↑	↑	↑	↑	↑	↑	↑	↑	↑	↑	↑	↑	↑	↑	↑	↑	↑	↑	↑	↑
b <sub>3</sub>	↑	↑	↑	↑	↑	↑	↑	↑	↑	↑	↑	↑	↑	↑	↑	↑	↑	↑	↑	↑	↑	↑	↑	↑	↑
b <sub>2</sub>	↑	↑	↑	↑	↑	↑	↑	↑	↑	↑	↑	↑	↑	↑	↑	↑	↑	↑	↑	↑	↑	↑	↑	↑	↑
b <sub>1</sub>	↑	↑	↑	↑	↑	↑	↑	↑	↑	↑	↑	↑	↑	↑	↑	↑	↑	↑	↑	↑	↑	↑	↑	↑	↑
column	0	0	0	0	0	0	0	0	0	0	0	0	0	0	0	0	0	0	0	0	0	0	0	0	0
0	0	0	0	0	0	0	0	0	0	0	0	0	0	0	0	0	0	0	0	0	0	0	0	0	0
1	0	0	0	0	0	0	0	0	0	0	0	0	0	0	0	0	0	0	0	0	0	0	0	0	0
2	0	0	0	0	0	0	0	0	0	0	0	0	0	0	0	0	0	0	0	0	0	0	0	0	0
3	0	0	0	0	0	0	0	0	0	0	0	0	0	0	0	0	0	0	0	0	0	0	0	0	0
4	0	0	0	0	0	0	0	0	0	0	0	0	0	0	0	0	0	0	0	0	0	0	0	0	0
5	0	0	0	0	0	0	0	0	0	0	0	0	0	0	0	0	0	0	0	0	0	0	0	0	0
6	0	0	0	0	0	0	0	0	0	0	0	0	0	0	0	0	0	0	0	0	0	0	0	0	0
7	0	0	0	0	0	0	0	0	0	0	0	0	0	0	0	0	0	0	0	0	0	0	0	0	0
8	1	0	0	0	0	0	0	0	0	0	0	0	0	0	0	0	0	0	0	0	0	0	0	0	0
9	1	0	0	0	0	0	0	0	0	0	0	0	0	0	0	0	0	0	0	0	0	0	0	0	0
10	1	0	0	0	0	0	0	0	0	0	0	0	0	0	0	0	0	0	0	0	0	0	0	0	0
11	1	0	0	0	0	0	0	0	0	0	0	0	0	0	0	0	0	0	0	0	0	0	0	0	0
12	1	1	0	0	0	0	0	0	0	0	0	0	0	0	0	0	0	0	0	0	0	0	0	0	0
13	1	1	0	0	0	0	0	0	0	0	0	0	0	0	0	0	0	0	0	0	0	0	0	0	0
14	1	1	0	0	0	0	0	0	0	0	0	0	0	0	0	0	0	0	0	0	0	0	0	0	0
15	1	1	0	0	0	0	0	0	0	0	0	0	0	0	0	0	0	0	0	0	0	0	0	0	0
15	1	1	1	1	1	1	1	1	1	1	1	1	1	1	1	1	1	1	1	1	1	1	1	1	1

Case using C12 C13 C14 = 001 (German Set)

\* \* These control characters are reserved for compatibility with other data codes.  
 \*\* These control characters are presumed before each row begins

5346-12.EPS

**FUNCTIONAL DESCRIPTION** (continued)

The basic set of the 96 characters is shown in Table 7. The location of the 13 national characters

are shown in Table 7 whilst full national character sets are depicted in Tables 8, 9 and 10.

**Table 7 : Basic Character Set.**

2/0		3/0		4/0	National Character	5/0		6/0	National Character	7/0	
2/1		3/1		4/1		5/1		6/1		7/1	
2/2		3/2		4/2		5/2		6/2		7/2	
2/3	National Character	3/3		4/3		5/3		6/3		7/3	
2/4	National Character	3/4		4/4		5/4		6/4		7/4	
2/5		3/5		4/5		5/5		6/5		7/5	
2/6		3/6		4/6		5/6		6/6		7/6	
2/7		3/7		4/7		5/7		6/7		7/7	
2/8		3/8		4/8		5/8		6/8		7/8	
2/9		3/9		4/9		5/9		6/9		7/9	
2/10		3/10		4/10		5/10		6/10		7/10	
2/11		3/11		4/11		5/11	National Character	6/11		7/11	National Character
2/12		3/12		4/12		5/12	National Character	6/12		7/12	National Character
2/13		3/13		4/13		5/13	National Character	6/13		7/13	National Character
2/14		3/14		4/14		5/14	National Character	6/14		7/14	National Character
2/15		3/15		4/15		5/15	National Character	6/15		7/15	



FUNCTIONAL DESCRIPTION (continued)

Table 8 : STV5346 Character Set - West European Languages

LANGUAGE	PHCB (1)			CHARACTER POSITION (COLUMN/ROW)												
	C12	C13	C14	2/3	2/4	4/0	5/11	5/12	5/13	5/14	5/15	6/0	7/11	7/12	7/13	7/14
ENGLISH	0	0	0													
GERMAN	0	0	1													
SWEDISH	0	1	0													
ITALIAN	0	1	1													
FRENCH	1	0	0													
SPANISH	1	0	1													

Note 1 : Where PHCB are the Page Header Control bits. Other Combinations default to English. Only the above characters change with the PHCB. All others characters in the basic set are shown in Table 7.

5346-14.EPS

FUNCTIONAL DESCRIPTION (continued)

Table 9 : STV5346/H Character Set - East European Languages

LANGUAGE	PHCB (1)			CHARACTER POSITION (COLUMN/ROW)													
	C12	C13	C14	2/3	2/4	4/0	5/11	5/12	5/13	5/14	5/15	6/0	7/11	7/12	7/13	7/14	
POLISH	0	0	0	▯	▯	▯	▯	▯	▯	▯	▯	▯	▯	▯	▯	▯	
GERMAN	0	0	1	▯	▯	▯	▯	▯	▯	▯	▯	▯	▯	▯	▯	▯	
SWEDISH	0	1	0	▯	▯	▯	▯	▯	▯	▯	▯	▯	▯	▯	▯	▯	
SERBO-CROAT	1	0	1	▯	▯	▯	▯	▯	▯	▯	▯	▯	▯	▯	▯	▯	
CZECHOSLOVAK	1	1	0	▯	▯	▯	▯	▯	▯	▯	▯	▯	▯	▯	▯	▯	
RUMANIAN	1	1	1	▯	▯	▯	▯	▯	▯	▯	▯	▯	▯	▯	▯	▯	

5346-15.EPS

Note 1 : Where PHCB are the Page Header Control bits. Other Combinations default to German. Only the above characters change with the PHCB. All others characters in the basic set are shown in Table 7.

Table 10 : STV5346/T Character Set - Turkish European Languages

LANGUAGE	PHCB (1)			CHARACTER POSITION (COLUMN/ROW)													
	C12	C13	C14	2/3	2/4	4/0	5/11	5/12	5/13	5/14	5/15	6/0	7/11	7/12	7/13	7/14	
ENGLISH	0	0	0	▯	▯	▯	▯	▯	▯	▯	▯	▯	▯	▯	▯	▯	
GERMAN	0	0	1	▯	▯	▯	▯	▯	▯	▯	▯	▯	▯	▯	▯	▯	
TURKISH	1	1	0	▯	▯	▯	▯	▯	▯	▯	▯	▯	▯	▯	▯	▯	
ITALIAN	0	1	1	▯	▯	▯	▯	▯	▯	▯	▯	▯	▯	▯	▯	▯	
FRENCH	1	0	0	▯	▯	▯	▯	▯	▯	▯	▯	▯	▯	▯	▯	▯	
SPANISH	1	0	1	▯	▯	▯	▯	▯	▯	▯	▯	▯	▯	▯	▯	▯	

5346-16.EPS

Note 1 : Where PHCB are the Page Header Control bits. Other Combinations default to Turkish. Only the above characters change with the PHCB. All others characters in the basic set are shown in Table 7.

FUNCTIONAL DESCRIPTION (continued)

Figure 7 : Character Format

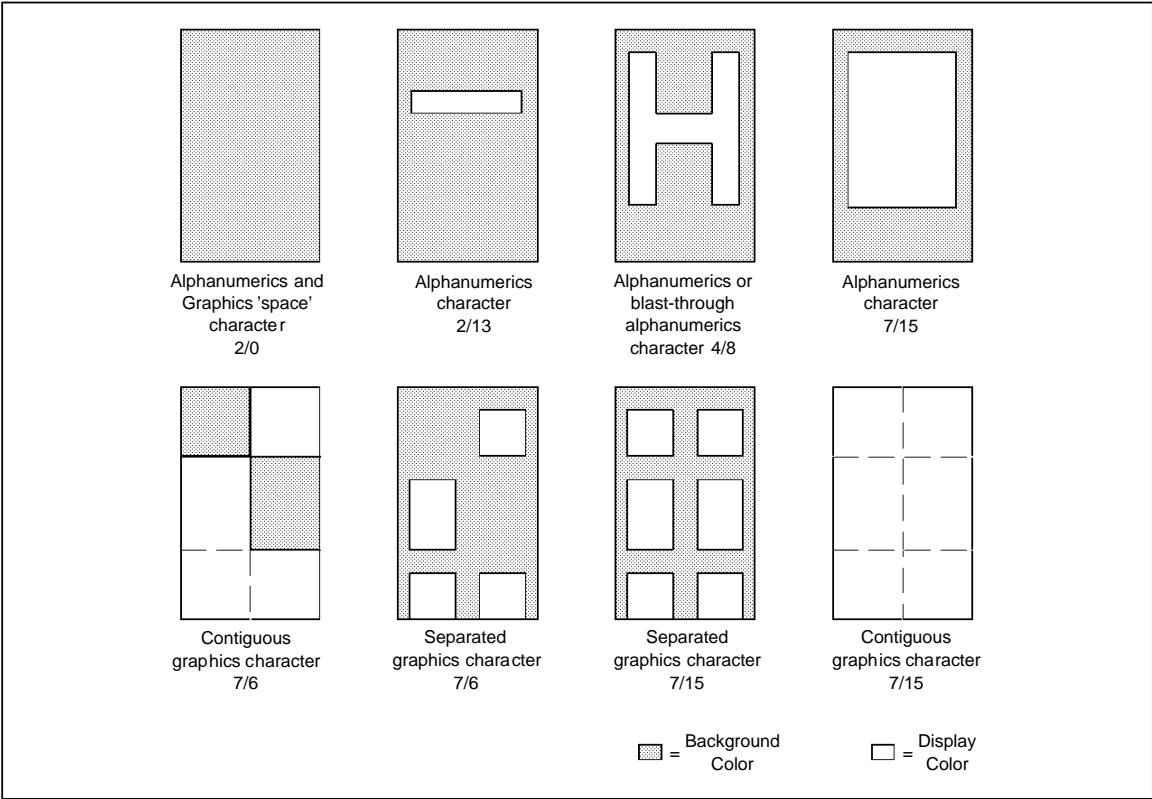

5346-17.EPS

**STV5346 - STV5346/H - STV5346/T**

**PACKAGE MECHANICAL DATA**  
28 PINS - PLASTIC DIP

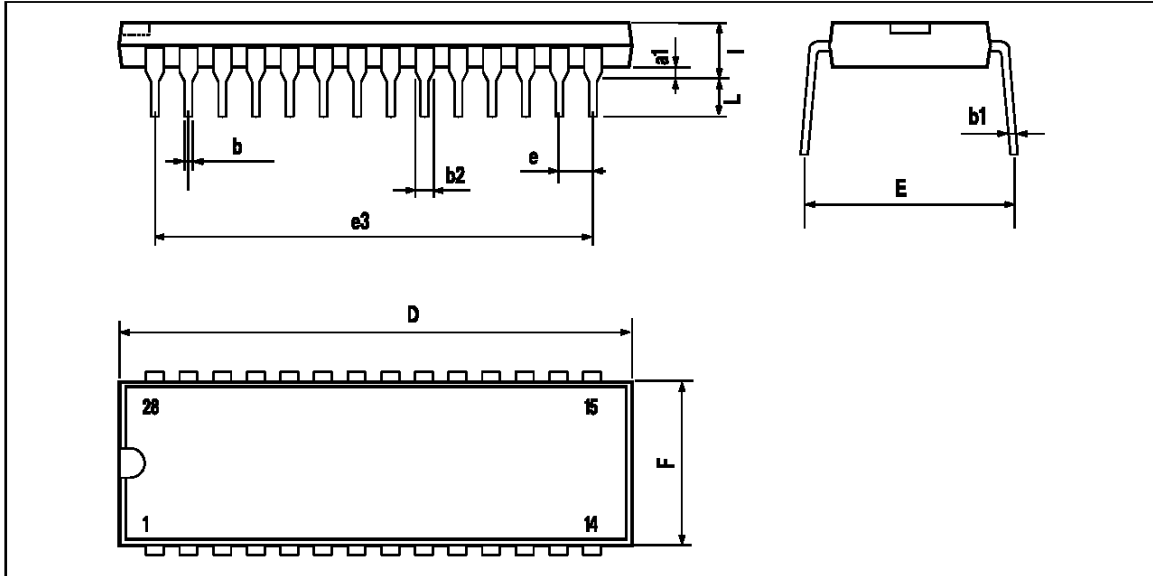

PM-DIP28EPS

Dimensions	Millimeters			Inches		
	Min.	Typ.	Max.	Min.	Typ.	Max.
a1		0.63			0.025	
b		0.45			0.018	
b1	0.23		0.31	0.009		0.012
b2		1.27			0.050	
D			37.4			1.470
E	15.2		16.68	0.598		0.657
e		2.54			0.100	
e3		33.02			1.300	
F			14.1			0.555
l		4.445			0.175	
L		3.3			0.130	

DIP28.TBL

**PACKAGE MECHANICAL DATA**  
28 PINS - PLASTIC MICROPACKAGE (SO)

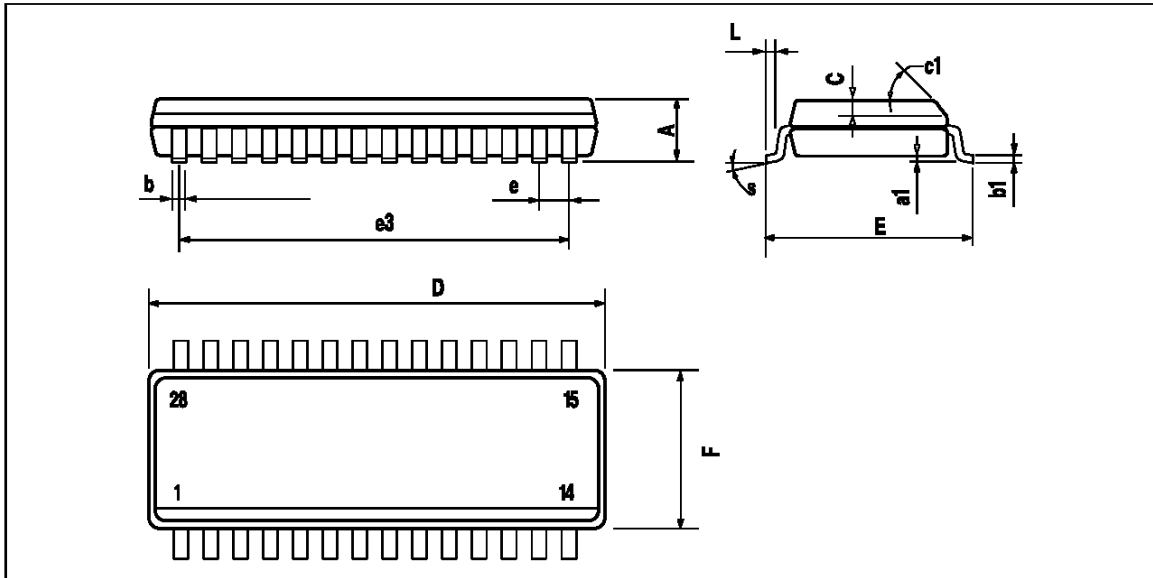

PM-SO28.EPS

Dimensions	Millimeters			Inches		
	Min.	Typ.	Max.	Min.	Typ.	Max.
A			2.65			0.104
a1	0.1		0.3	0.004		0.012
b	0.35		0.49	0.014		0.019
b1	0.23		0.32	0.009		0.013
C		0.5			0.020	
c1	45° (typ.)					
D	17.7		18.1	0.697		0.713
E	10		10.65	0.394		0.419
e		1.27			0.050	
e3		16.51			0.65	
F	7.4		7.6	0.291		0.299
L	0.4		1.27	0.016		0.050
S	8° (max.)					

SO28.TBL

Information furnished is believed to be accurate and reliable. However, SGS-THOMSON Microelectronics assumes no responsibility for the consequences of use of such information nor for any infringement of patents or other rights of third parties which may result from its use. No licence is granted by implication or otherwise under any patent or patent rights of SGS-THOMSON Microelectronics. Specifications mentioned in this publication are subject to change without notice. This publication supersedes and replaces all information previously supplied. SGS-THOMSON Microelectronics products are not authorized for use as critical components in life support devices or systems without express written approval of SGS-THOMSON Microelectronics.

© 1995 SGS-THOMSON Microelectronics - All Rights Reserved

Purchase of  $\mu$ C Components of SGS-THOMSON Microelectronics, conveys a license under the Philips  $\mu$ C Patent. Rights to use these components in a  $\mu$ C system, is granted provided that the system conforms to the  $\mu$ C Standard Specifications as defined by Philips.

SGS-THOMSON Microelectronics GROUP OF COMPANIES

Australia - Brazil - China - France - Germany - Hong Kong - Italy - Japan - Korea - Malaysia - Malta - Morocco  
The Netherlands - Singapore - Spain - Sweden - Switzerland - Taiwan - Thailand - United Kingdom - U.S.A.