



# STV8162 - STV8162D

## +5 V, +5 V and +8 V Triple-Voltage Regulator with Disable and Reset Functions

DATASHEET

### Key Features

- Input Voltage range between 7 V and 18 V
- Output Currents up to 600 mA
- Fixed Precision Output 1 voltage of 5 V  $\pm$  2%
- Fixed Precision Output 2 voltage of 5 V  $\pm$  2%
- Fixed Precision Output 3 voltage of 8 V  $\pm$  2%
- Output 1 with Reset facility
- Outputs 2 and 3 can be disabled by digital input
- Short Circuit Protection on each output
- Thermal Protection
- Low Dropout Voltages

### DESCRIPTION

The STV8162 and STV8162D are monolithic triple positive voltage regulators designed to provide three fixed precision output voltages of 5 V, 5 V and 8 V for currents up to 0.6 A.

An internal reset circuit generates a reset pulse when the voltage of Output 1 drops below the regulated voltage value.

Outputs 2 and 3 can be disabled by a digital input.

Short-circuit and thermal protections are included in all versions.

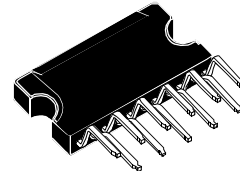

**Clipwatt 11**  
Order Code: STV8162

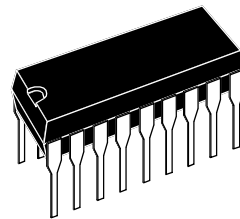

**Power DIP 18 (9 + 9)**  
Order Code: STV8162D

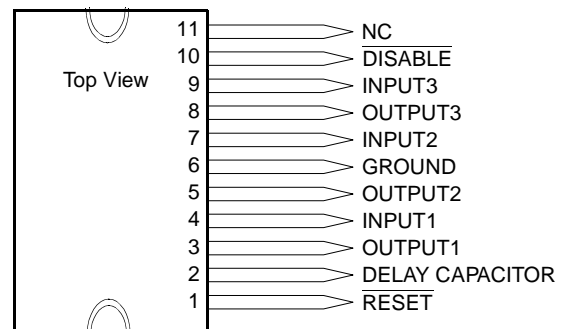
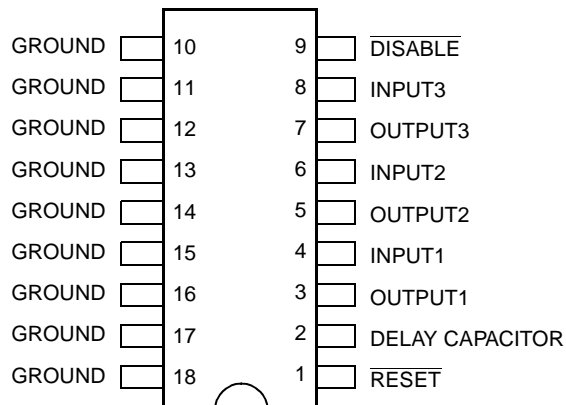

# 1 GENERAL INFORMATION

Figure 1: STV8162 Block Diagram

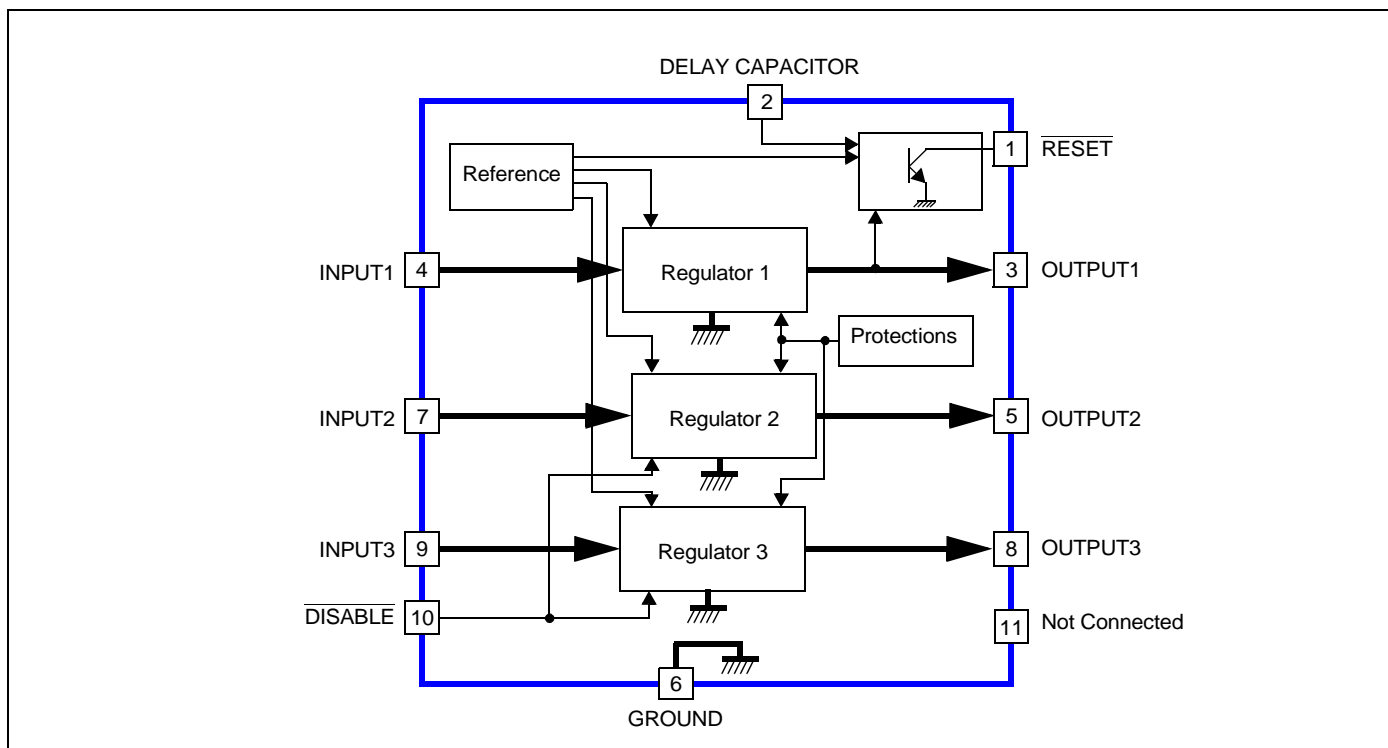

DataSheet4U.com

Figure 2: STV8162D Block Diagram

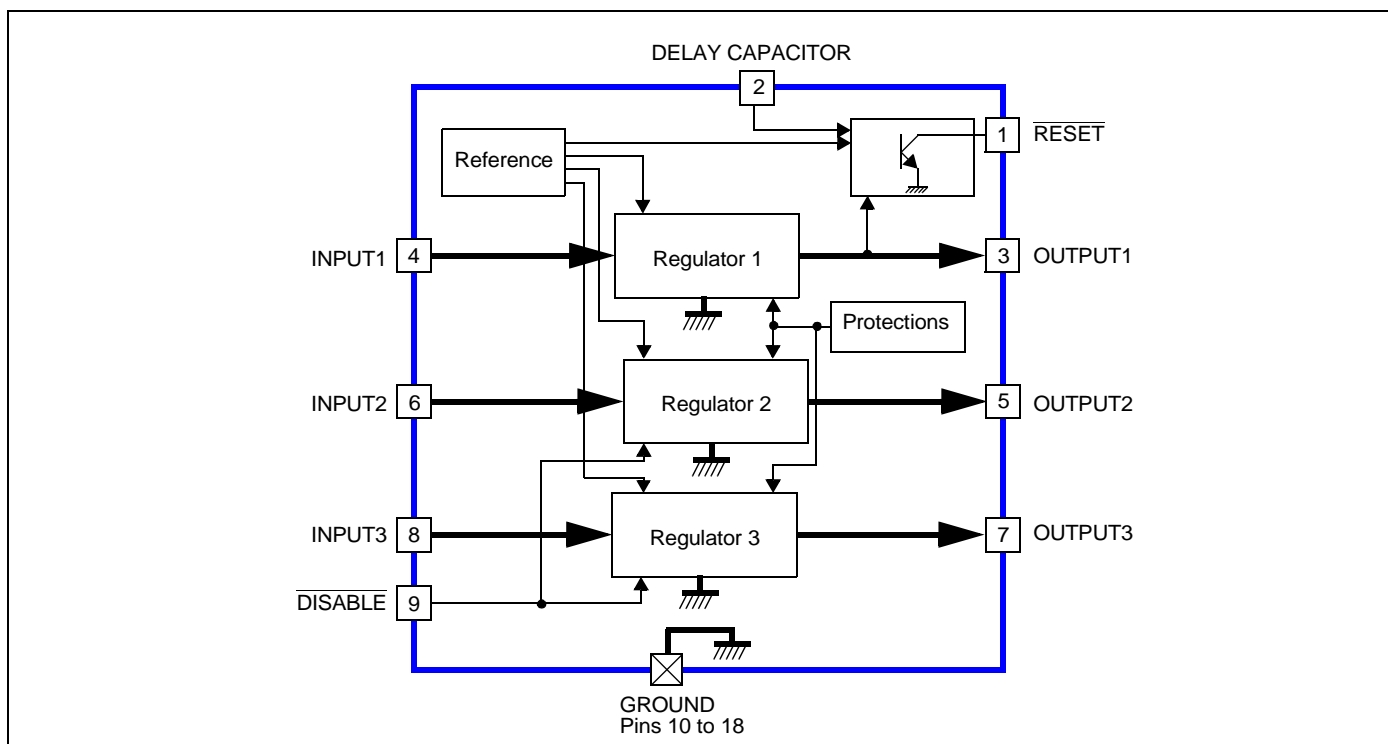

## 2 Electrical Characteristics

### 2.1 Absolute Maximum Ratings

Symbol	Parameter	Value	Unit
$V_{IN}$	DC Input Voltage at pins INPUT1, INPUT2 and INPUT3	20	V
$V_{DIS}$	Disable Input Voltage at pin $\overline{DISABLE}$	20	V
$V_{RST}$	Output Voltage at pin $\overline{RESET}$	20	V
$I_{OUTPUT}$	Output Currents	Internally Limited	
$P_t$	Power Dissipation	Internally Limited	
$T_{STG}$	Storage Temperature	-65 to +150	°C
$T_J$	Junction Temperature	0 to +150	°C

### 2.2 Thermal Data

Symbol	Parameter	Value	Unit
$R_{thJC}$	Junction-to-Case Thermal Resistance	STV8162 3 STV8162D 15	°C/W
$R_{thJA}$	Junction-to-Ambient Thermal Resistance <sup>1</sup>	STV8162 ≥10 STV8162D 56	°C/W
$T_J$	Maximum Recommended Junction Temperature	140	°C
$T_{OPER}$	Operating Free Air Temperature Range	0 to +70	°C

1. Mounted on board. For more information, refer to [Section 5](#).

### 2.3 Electrical Characteristics

$T_{AMB} = 25^\circ\text{C}$ ,  $V_{IN1} = 7\text{V}$ ,  $V_{IN2} = 7\text{V}$  and  $V_{IN3} = 10\text{V}$ , unless otherwise specified.

Symbol	Parameter	Test Conditions	Min.	Typ.	Max.	Unit
$V_{OUT1}$	Output Voltage	$I_{OUT1} = 10\text{mA}$	4.90	5.00	5.10	V
$V_{OUT2}$	Output Voltage	$I_{OUT2} = 10\text{mA}$	4.90	5.00	5.10	V
$V_{OUT3}$	Output Voltage	$I_{OUT3} = 10\text{mA}$	7.84	8.00	8.16	V
$V_{OUT1}$	Output Voltage	$7\text{V} < V_{IN1} < 12\text{V}$ $5\text{mA} < I_{OUT1} < 600\text{mA}$	4.80		5.20	V
$V_{OUT2}$	Output Voltage	$7\text{V} < V_{IN2} < 12\text{V}$ $5\text{mA} < I_{OUT2} < 600\text{mA}$	4.80		5.20	V
$V_{OUT3}$	Output Voltage	$10\text{V} < V_{IN3} < 15\text{V}$ $5\text{mA} < I_{OUT3} < 600\text{mA}$	7.68		8.32	V

Symbol	Parameter	Test Conditions	Min.	Typ.	Max.	Unit
V <sub>IO1</sub>	Dropout Voltage	I <sub>OUT1</sub> = 0.6 A		1	1.4	V
V <sub>IO2</sub>	Dropout Voltage	I <sub>OUT2</sub> = 0.6 A		1	1.4	V
V <sub>IO3</sub>	Dropout Voltage	I <sub>OUT3</sub> = 0.6 A		1	1.4	V
V <sub>OUT1LI</sub>	Line Regulation	7 V < V <sub>IN1</sub> < 12 V, I <sub>OUT1</sub> = 200 mA			50	mV
V <sub>OUT2LI</sub>	Line Regulation	7 V < V <sub>IN2</sub> < 12 V, I <sub>OUT2</sub> = 200 mA			50	mV
V <sub>OUT3LI</sub>	Line Regulation	10 V < V <sub>IN3</sub> < 15 V, I <sub>OUT3</sub> = 200 mA			80	mV
V <sub>OUT1LO</sub>	Load Regulation	5 mA < I <sub>OUT1</sub> < 600 mA			100	mV
V <sub>OUT2LO</sub>	Load Regulation	5 mA < I <sub>OUT2</sub> < 600 mA			100	mV
V <sub>OUT3LO</sub>	Load Regulation	5 mA < I <sub>OUT3</sub> < 600 mA			160	mV
I <sub>Q</sub>	Quiescent Current	I <sub>OUT1</sub> = 10 mA Outputs 2 and 3 disabled		2.2	3.0	mA
V <sub>O1RST</sub>	Reset Threshold Voltage	K = V <sub>OUT1</sub>	K-0.4	K-0.25	K-0.10	V
V <sub>RTH</sub>	Reset Threshold Hysteresis	See circuit description.	30	75	120	mV
t <sub>RD</sub>	Reset Pulse Delay	C <sub>e</sub> = 100 nF See circuit description.		25		ms
V <sub>RL</sub>	Saturation Voltage in Reset Condition	I <sub>RESET</sub> = 5 mA			0.4	V
I <sub>RH</sub>	Leakage Current in Normal Condition, at RESET pin	V <sub>RESET</sub> = 10 V			10	μA
K <sub>OUT1</sub> K <sub>OUT2</sub> K <sub>OUT3</sub>	Output Voltage Thermal Drift	T <sub>J</sub> = 0 to 125°C $K_{OUT} = \frac{\Delta V_{OUT} \cdot 10^6}{\Delta T \cdot V_{OUT}}$		100		ppm/°C
I <sub>OUT1SC</sub>	Short Circuit Output Current	V <sub>IN1</sub> = 7 V	0.8	1.3	1.8	A
I <sub>OUT2SC</sub>	Short Circuit Output Current	V <sub>IN1</sub> = 7 V	0.8	1.3	1.8	A
I <sub>OUT3SC</sub>	Short Circuit Output Current	V <sub>IN3</sub> = 10 V	0.8	1.3	1.8	A
V <sub>DISH</sub>	Voltage High Level at $\overline{\text{DISABLE}}$ pin (Outputs 2 and 3 active)		2			V
V <sub>DISL</sub>	Voltage Low Level at $\overline{\text{DISABLE}}$ pin (Outputs 2 and 3 disabled)				0.8	V
I <sub>DIS</sub>	Bias Current at $\overline{\text{DISABLE}}$ pin	0 V < V <sub>DISABLE</sub> < 7 V	-100		2	μA
T <sub>JSD</sub>	Junction Temperature for Thermal Shutdown			150		°C
T <sub>SDH</sub>	Thermal Shutdown Temperature Hysteresis			15		°C

### 3 Circuit Description

The STV8162 and STV8162D are triple-voltage regulators with Reset and Disable functions.

The three regulation parts are supplied from a single voltage reference circuit trimmed by zener zapping during EWS testing. Since the supply voltage of this voltage reference is connected to pin INPUT1 ( $V_{IN1}$ ), the second and third regulators will not work if pin INPUT1 is not supplied.

The output stages are designed using a Darlington configuration with a typical dropout voltage of 1.0 V.

**IMPORTANT:** *In all applications, all three inputs must be polarized. If Outputs 2 or 3 are not used, the corresponding inputs must be connected to Input 1.*

The Disable circuit will switch off pins OUTPUT2 and OUTPUT3 if a voltage less than 0.8 V is applied to pin DISABLE.

The Reset circuit checks the voltage at pin OUTPUT1. If this voltage drops below  $V_{OUT1}-0.25$  V (4.75 V Typ.), the "a" comparator (Figure 3) rapidly discharges the external capacitor ( $C_e$ ) and the reset output immediately switches to low. When the voltage at pin OUTPUT1 exceeds  $V_{OUT1}-0.175$  V (4.825 V Typ.), the  $V_{C_e}$  voltage increases linearly to the reference voltage ( $V_{REF} = 2.5$  V) corresponding to a Reset Pulse Delay ( $t_{RD}$ ) as shown in Figure 4.

$$t_{RD} = \frac{C_e \times 2.5V}{10\mu A}$$

Afterwards, the reset output returns to high. To avoid glitches in the reset output, the second comparator "b" has a large hysteresis (1.9 V).

## 4 Application Diagrams

Figure 3: Reset Diagram

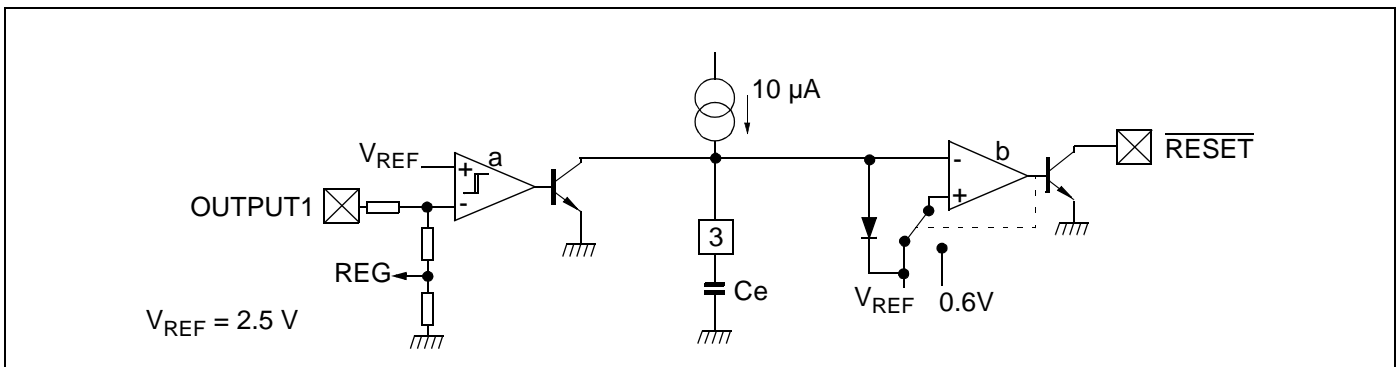

Figure 4: Internal Reset Voltage

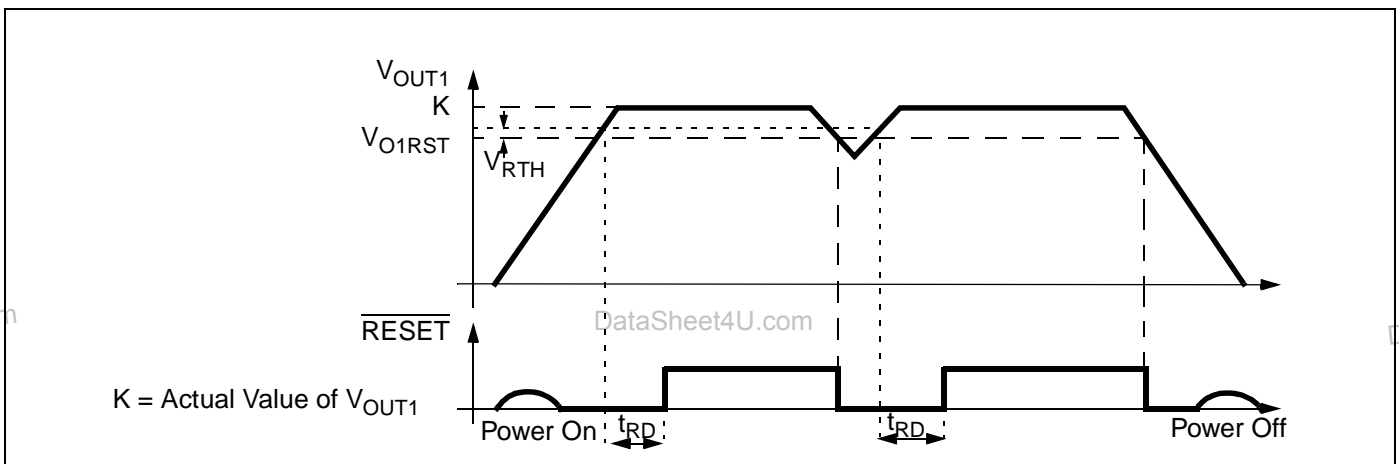

Figure 5: STV8162 Typical Application

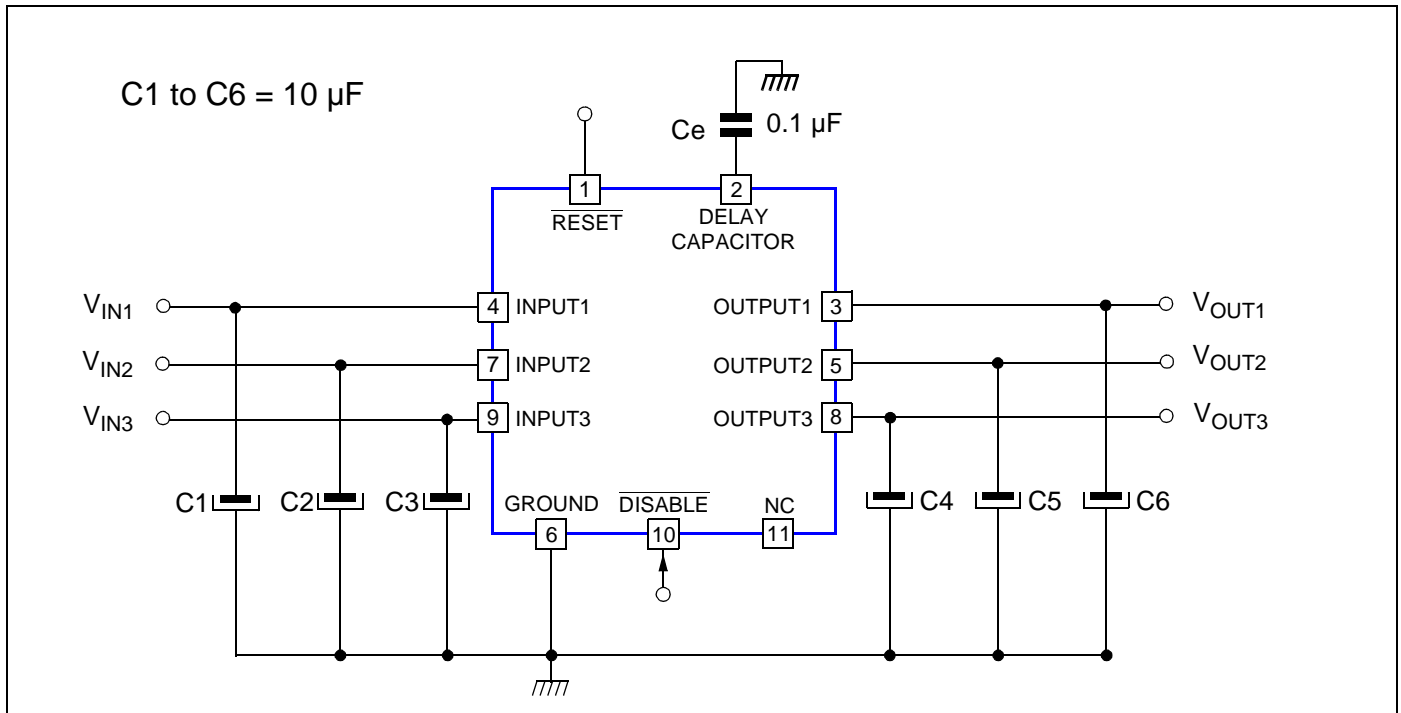
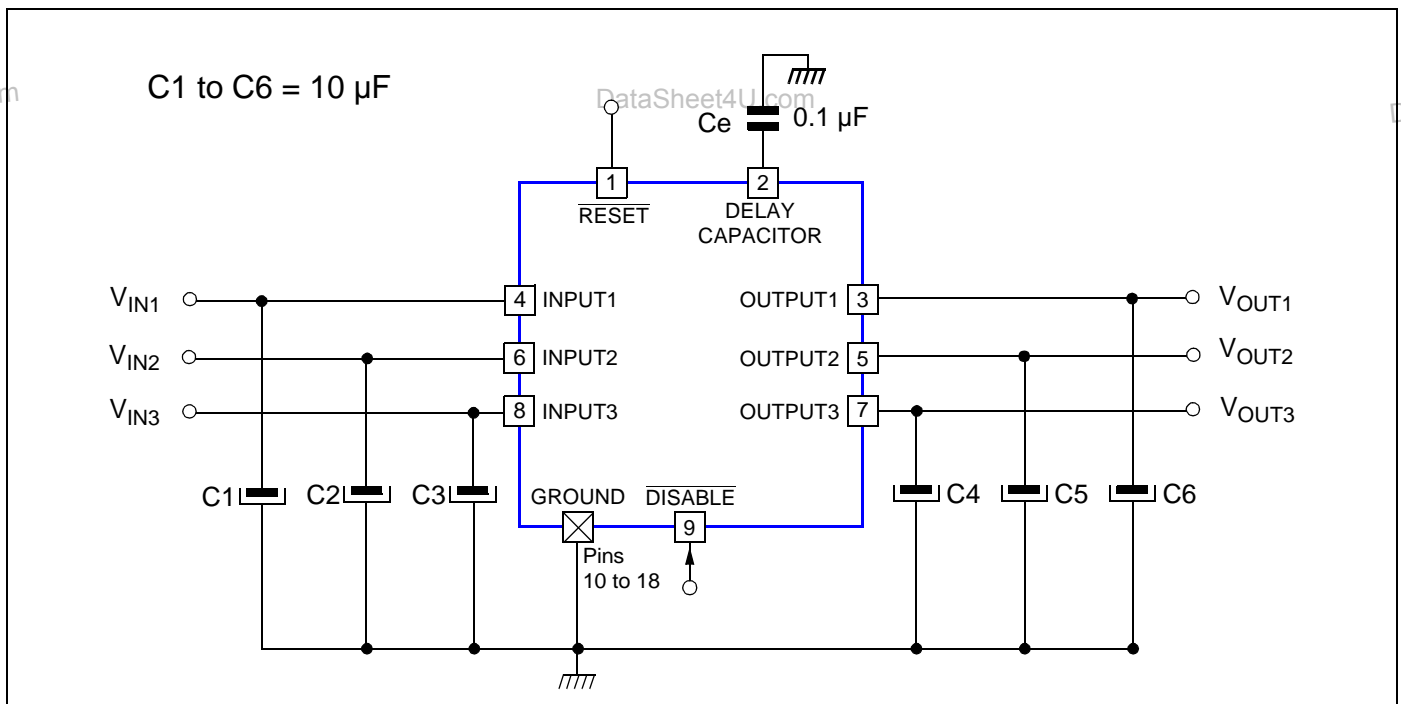

Figure 6: STV8162D Typical Application



## 5 Power Dissipation and Layout Indications

The power is mainly dissipated by the three device buffers. It can be calculated by the equation:

$$P = (V_{IN1} - V_{OUT1}) \times I_{OUT1} + (V_{IN2} - V_{OUT2}) \times I_{OUT2} + (V_{IN3} - V_{OUT3}) \times I_{OUT3}$$

The following table lists the different  $R_{thJA}$  values of these packages with or without a heat sink and the corresponding maximum power dissipation assuming:

- Maximum Ambient Temperature = 70° C
- Maximum Junction Temperature = 140° C

Device	Heat Sink	$R_{thJA}$ in °C/W	$P_{MAX}$ in W
STV8162	No	50	1.4
	Yes	15	4.6
STV8162D	No	56 to 40	1.25 to 1.75
	Yes	32	2.2

Figure 7: Thermal Resistance (Junction-to-Ambient) of DIP18 Package without Heat Sink

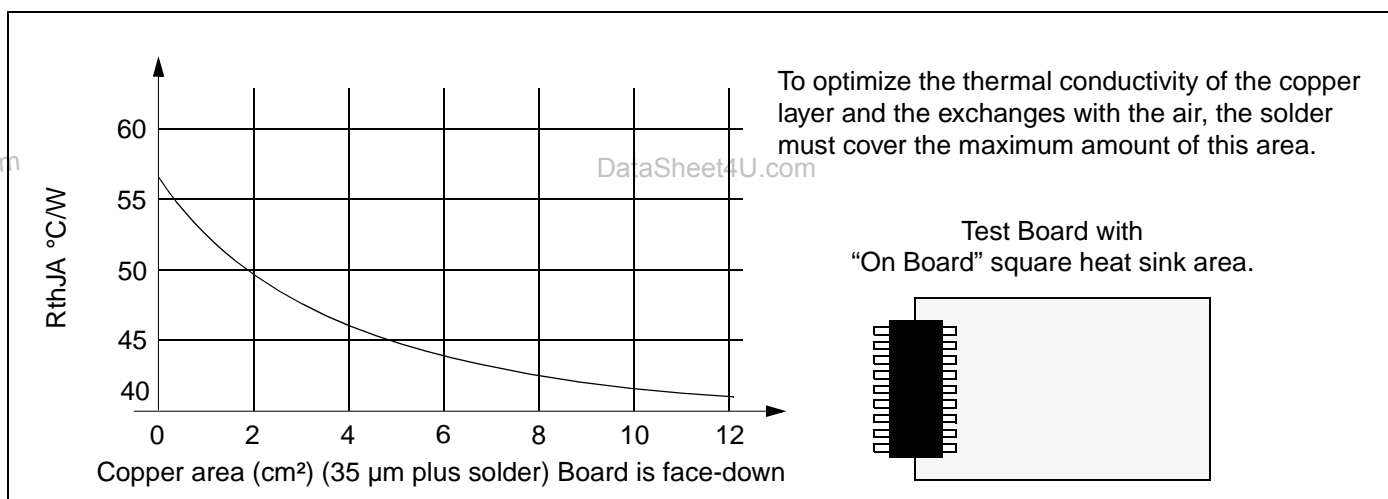
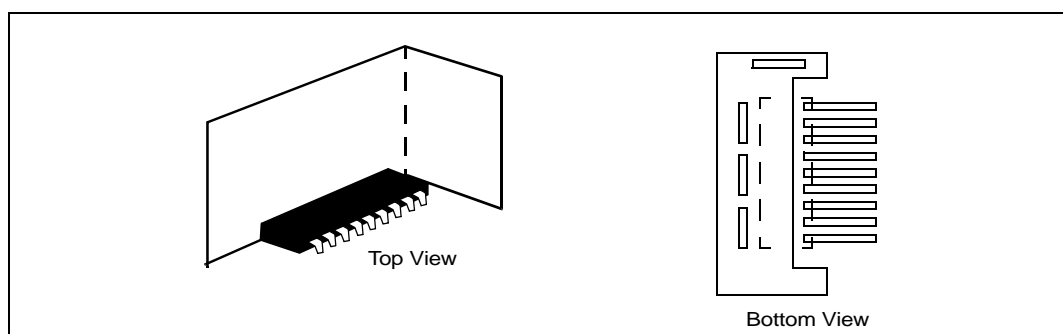

Figure 8: Metal plate mounted near the STV8162D for heat sinking





## 6 Package Mechanical Data

Figure 9: 11-pin Plastic Clipwatt Package

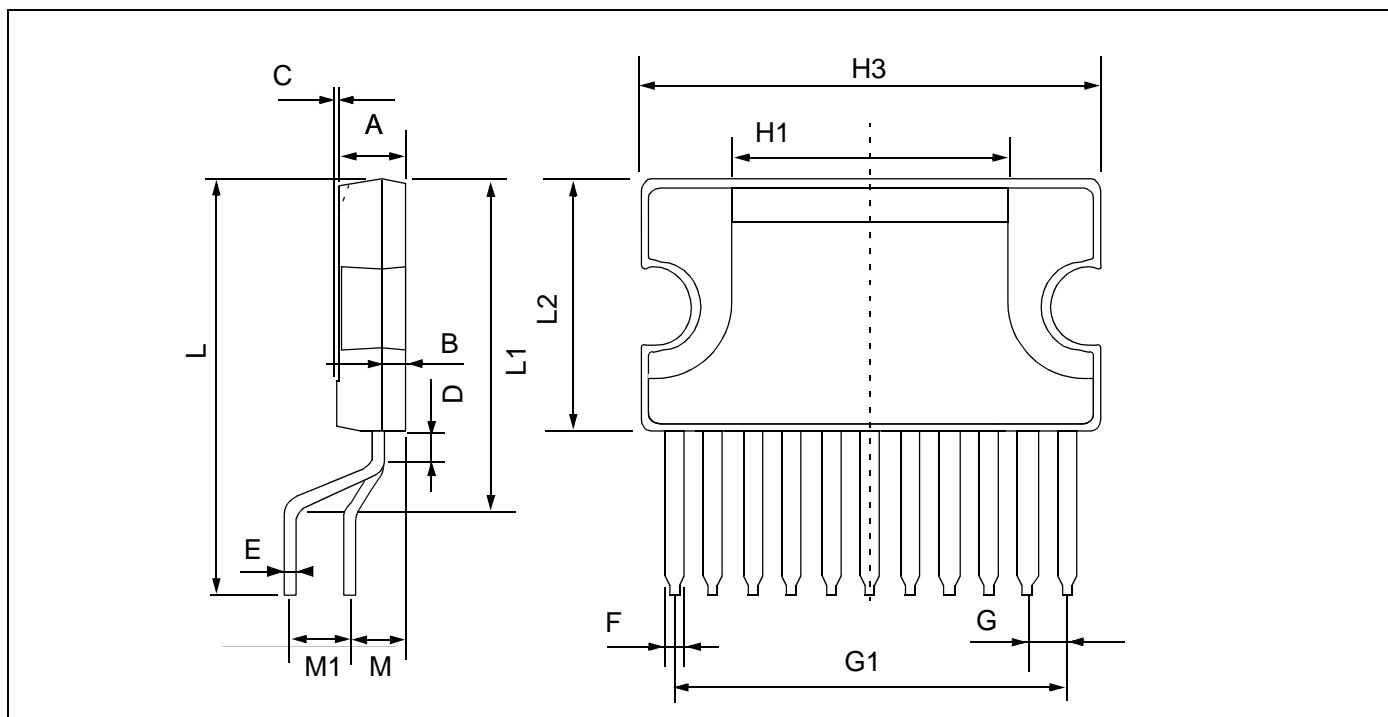

Dim.	mm			Inches		
	Min.	Typ.	Max.	Min.	Typ.	Max.
A			3.20			0.126
B			1.05			0.041
C		0.15			0.006	
D		1.50			0.059	
E	0.49	0.55		0.019	0.002	
F	0.80		0.91	0.031		0.036
G	1.57	1.70	1.83	0.062	0.067	0.072
H1		12.00			0.480	
H2		18.60			0.732	
H3	19.85			0.781		
L		17.90			0.700	
L1		14.45			0.569	
L2	10.70	11.00	11.20	0.421	0.433	0.441
L3		5.50			0.217	
M		2.54			0.100	
M1		2.54			0.100	
	<b>Number of Pins</b>					
N	11					

Figure 10: 18-pin Plastic Dual In-line Power Package

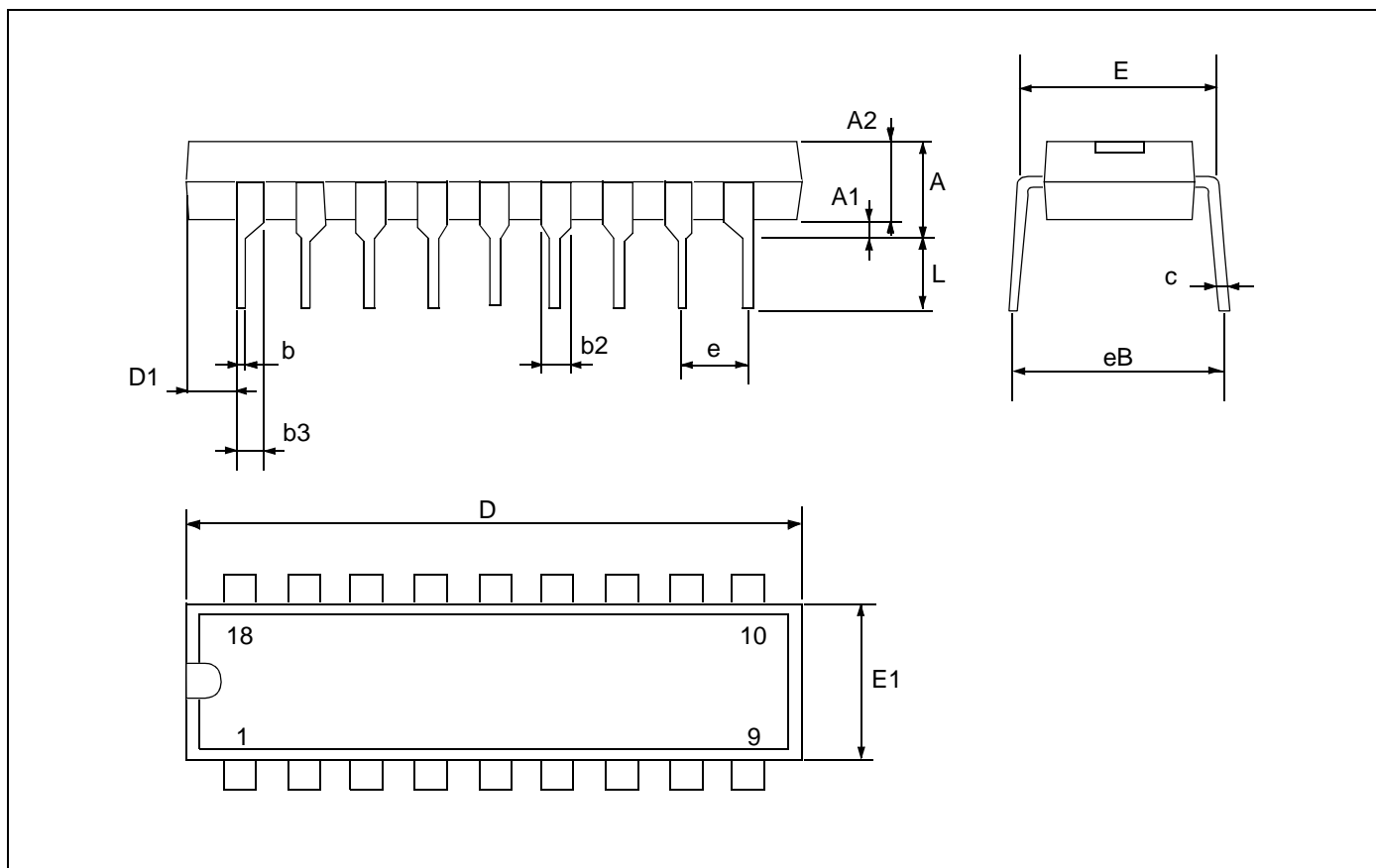

et4U.com

DataSheet4U.com

DataShee

Dim.	mm			Inches		
	Min.	Typ.	Max.	Min.	Typ.	Max.
A			5.33			0.210
A1	0.38			0.015		
A2	2.92	3.30	4.95	0.115	0.130	0.195
b	0.36	0.46	0.56	0.014	0.018	0.022
b2	1.14	1.52	1.78	0.045	0.060	0.070
b3	0.76	0.99	1.14	0.030	0.039	0.045
c	0.20	0.25	0.36	0.008	0.010	0.014
D	22.35	22.86	23.37	0.880	0.900	0.920
D1	0.13			0.005		
e		2.54			0.100	
eB			10.92			0.430
E	7.62	7.87	8.26	0.300	0.310	0.325
E1	6.10	6.35	7.11	0.240	0.250	0.280
L	2.92	3.30	3.81	0.115	0.130	0.150

## 7 Revision History

Table 1: Summary of Modifications

Version	Date	Main Changes
0.2	January 2000	First Edition
0.3	November 2002	Addition of PDIP18 package.

**NOTES:**

et4U.com

DataSheet4U.com

Information furnished is believed to be accurate and reliable. However, STMicroelectronics assumes no responsibility for the consequences of use of such information nor for any infringement of patents or other rights of third parties which may result from its use. No license is granted by implication or otherwise under any patent or patent rights of STMicroelectronics. Specifications mentioned in this publication are subject to change without notice. This publication supersedes and replaces all information previously supplied. STMicroelectronics products are not authorized for use as critical components in life support devices or systems without express written approval of STMicroelectronics.

The ST logo is a registered trademark of STMicroelectronics

All other names are the property of their respective owners

© 2004 STMicroelectronics - All rights reserved

STMicroelectronics GROUP OF COMPANIES

Australia - Belgium - Brazil - Canada - China - Czech Republic - Finland - France - Germany - Hong Kong - India - Israel - Italy  
- Japan - Malaysia - Malta - Morocco - Singapore - Spain - Sweden - Switzerland - United Kingdom - United States

[www.st.com](http://www.st.com)

DataSheet4U.com