

120A, 100V N-CHANNEL MOSFET

DESCRIPTION

SVG105R4NT(S)(KL) is an N-channel enhancement mode power MOS field effect transistor which is produced using Silan's LVMOS technology. The improved process and cell structure have been especially tailored to minimize on-state resistance, provide superior switching performance.

This device is widely used in power management for UPS and Inverter Systems.

FEATURES

- ◆ 120A, 100V, $R_{DS(on)(typ.)} = 5.0m\Omega @ V_{GS}=10V$
- ◆ Low gate charge
- ◆ Low C_{rss}
- ◆ Fast switching
- ◆ Extreme dv/dt rated
- ◆ 100% avalanche tested
- ◆ Pb-free lead plating
- ◆ RoHS compliant

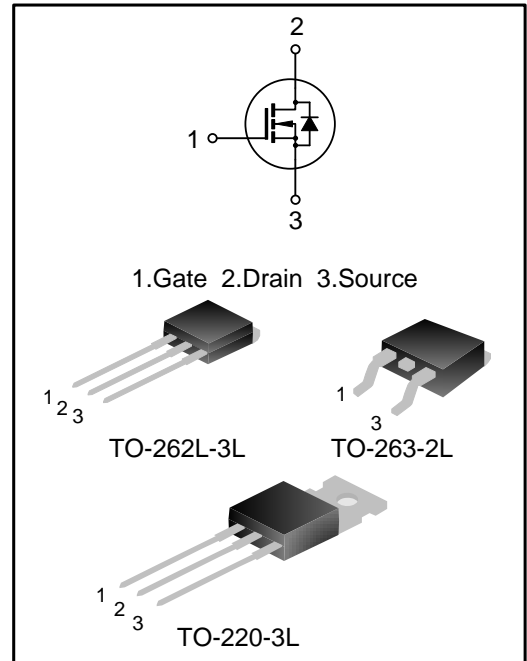

KEY PERFORMANCE PARAMETERS

Characteristics	Ratings	Unit
V_{DS}	100	V
$V_{GS(th)}$	2.0~4.0	V
$R_{DS(on),max}$	5.4	$m\Omega$
I_D	120	A
$Q_{g,typ}$	64	nC

ORDERING INFORMATION

Part No.	Package	Marking	Hazardous Substance Control	Packing Type
SVG105R4NT	TO-220-3L	105R4NT	Pb free	Tube
SVG105R4NS	TO-263-2L	105R4NS	Halogen free	Tube
SVG105R4NSTR	TO-263-2L	105R4NS	Halogen free	Tape&Reel
SVG105R4NKL	TO-262L-3L	105R4NKL	Pb free	Tube

ABSOLUTE MAXIMUM RATINGS (UNLESS OTHERWISE NOTED, T_J=25°C)

Characteristics	Symbol	Test conditions	Ratings			Unit
			Min.	Typ.	Max.	
Drain-source Voltage	V _{DS}	--	100	--	--	V
Gate-source Voltage	V _{GS}	--	-20	--	20	V
Drain Current	I _D	T _C =25°C	--	--	120	A
		T _C =100°C	--	--	90	A
Drain Current Pulsed (Note 1)	I _{DM}	T _C =25°C	--	--	480	A
Power Dissipation (Note 2)	P _D	T _C =25°C	--	--	160	W
Single Pulsed Avalanche Energy	E _{AS}	L=0.5mH, V _{DD} =50V, R _G =25Ω, starting temperature T _J =25°C	--	--	400	mJ
Single Pulsed Avalanche Current	I _{AS}	--	--	--	40	A
Operation Junction Temperature Range	T _J	--	-55	--	150	°C
Storage Temperature Range	T _{stg}	--	-55	--	150	°C

THERMAL CHARACTERISTICS

Table 1. Thermal characteristics of TO-220-3L/TO-262-3L (SVG105R4NT/KL)

Characteristics	Symbol	Test conditions	Ratings			Unit
			Min.	Typ.	Max.	
Thermal Resistance, Junction-case, Bottom	R _{θJC}	--	--	--	0.78	°C/W
Thermal Resistance, Junction-ambient	R _{θJA}	--	--	--	62.5	°C/W
Soldering Temperature (in line)	T _{sold}	15 ⁺² ₀ sec, 1 time	--	--	260	°C

Table 2. Thermal characteristics of TO-263-2L (SVG105R4NS)

Characteristics	Symbol	Test conditions	Ratings			Unit
			Min.	Typ.	Max.	
Thermal Resistance, Junction-case, Bottom	R _{θJC}	--	--	--	0.78	°C/W
Thermal Resistance, Junction-ambient	R _{θJA}	--	--	--	62.5	°C/W
Soldering Temperature (SMD)	T _{sold}	Reflow soldering: 10±1sec, 3times Wave soldering: 10 ⁺² ₀ sec, 1time	--	--	260	°C

ELECTRICAL CHARACTERISTICS (UNLESS OTHERWISE NOTED, $T_J=25^\circ\text{C}$)

Static characteristics

Characteristics	Symbol	Test conditions	Ratings			Unit
			Min.	Typ.	Max.	
Drain-source Breakdown Voltage	BV_{DSS}	$V_{GS}=0V, I_D=250\mu A$	100	--	--	V
Drain-source Leakage Current	I_{DSS}	$V_{DS}=100V, V_{GS}=0V, T_J=25^\circ\text{C}$	--	--	1.0	μA
Gate-source Leakage Current	I_{GSS}	$V_{GS}=\pm 20V, V_{DS}=0V$	--	--	± 100	nA
Gate Threshold Voltage	$V_{GS(th)}$	$V_{GS}=V_{DS}, I_D=250\mu A$	2.0	--	4.0	V
Static Drain-source On State Resistance	$R_{DS(on)}$	$V_{GS}=10V, I_D=50A$	--	5.0	5.4	$m\Omega$
Gate Resistance	R_g	$f=1\text{MHz}$	--	3.0	--	Ω

Dynamic characteristics

Characteristics	Symbol	Test conditions	Ratings			Unit
			Min.	Typ.	Max.	
Input Capacitance	C_{iss}	$f=1\text{MHz}, V_{GS}=0V, V_{DS}=40V$	--	3815	--	pF
Output Capacitance	C_{oss}		--	652	--	
Reverse Transfer Capacitance	C_{rss}		--	26	--	
Turn-on Delay Time	$t_{d(on)}$	$V_{DD}=40V, V_{GS}=10V, R_G=24\Omega, I_D=13.3A$ (Notes 3,4)	--	49	--	ns
Turn-on Rise Time	t_r		--	76	--	
Turn-off Delay Time	$t_{d(off)}$		--	157	--	
Turn-off Fall Time	t_f		--	87	--	
Total Gate Charge	Q_g	$V_{DD}=40V, V_{GS}=10V, I_D=50A$ (Notes 3,4)	--	64	--	nC
Gate-source Charge	Q_{gs}		--	23	--	
Gate-drain Charge	Q_{gd}		--	17	--	
Gate-plateau Voltage	$V_{plateau}$		--	5.7	--	

Reverse diode characteristics

Characteristics	Symbol	Test conditions	Ratings			Unit
			Min.	Typ.	Max.	
Continuous Diode Forward Current	I_S	$T_C=25^\circ\text{C}$, integral reverse P-N junction diode in the MOSFET	--	--	120	A
Diode Pulse Current	$I_{S,pulse}$		--	--	480	
Diode Forward Voltage	V_{SD}	$I_S=50A, V_{GS}=0V$	--	--	1.4	V
Reverse Recovery Time	T_{rr}	$I_S=20A, V_{GS}=0V, dI_F/dt=100A/\mu s$ (Note 3)	--	66	--	ns
Reverse Recovery Charge	Q_{rr}		--	0.15	--	μC

Notes:

- Pulse time $5\mu s$;
- The dissipation power will change with temperature, derating above 25°C : $1.3W/^\circ\text{C}$;
- Pulse Test: Pulse width $\leq 300\mu s$, Duty cycle $\leq 2\%$;
- Essentially independent of operating temperature.

TYPICAL CHARACTERISTICS

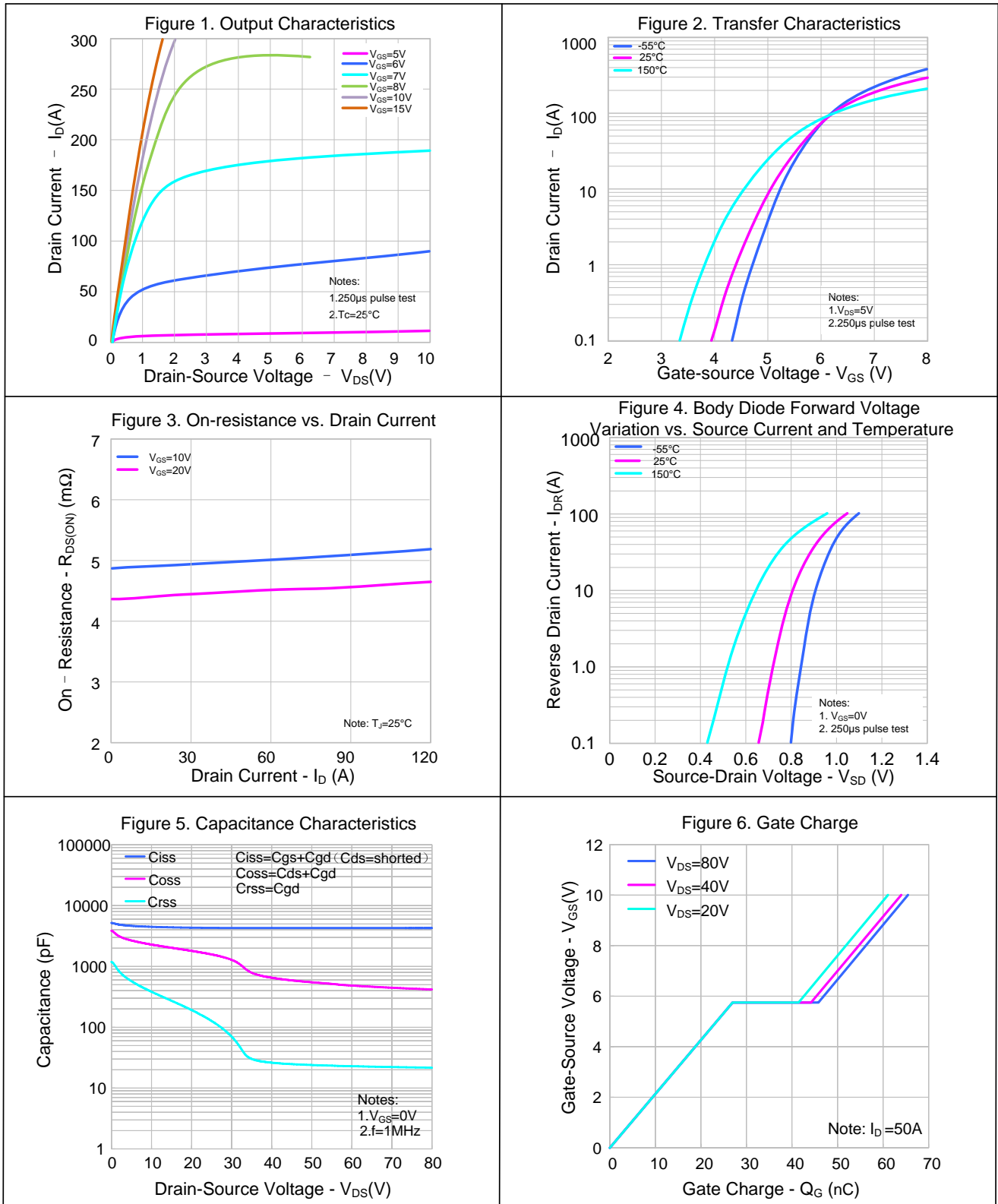

TYPICAL CHARACTERISTICS (CONTINUED)

Figure 7. Breakdown Voltage Variation vs. Temperature

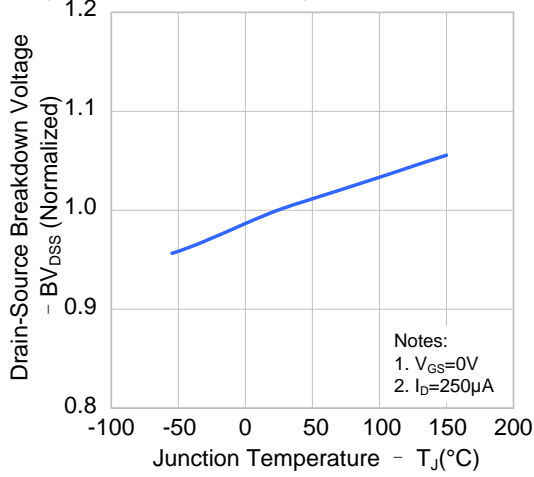

Figure 8. On-resistance Variation vs. Temperature

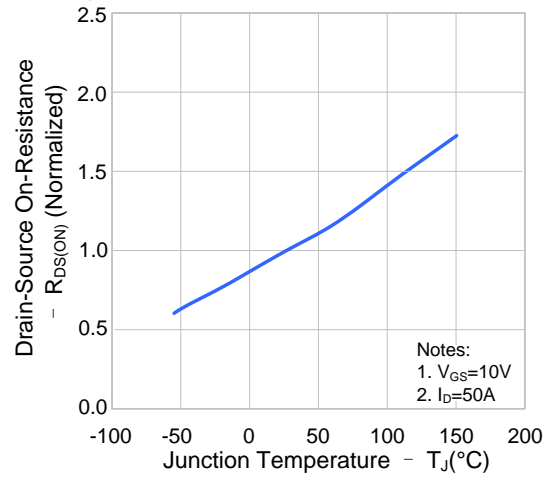
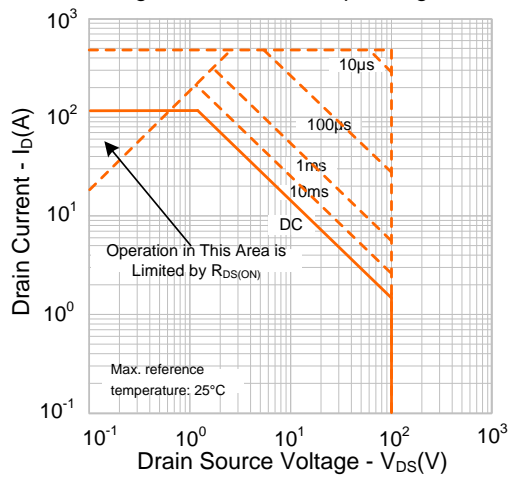
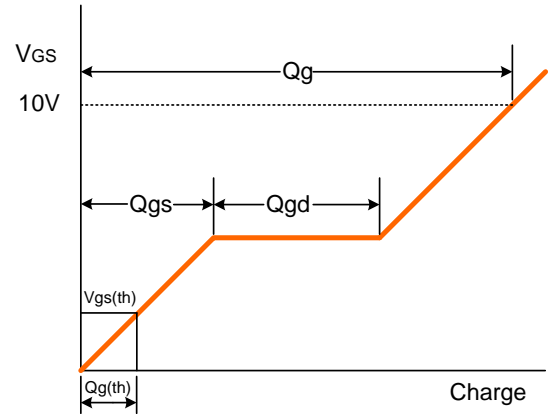
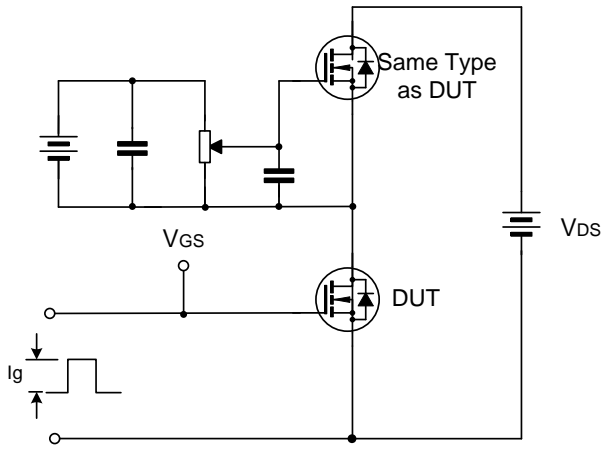

Figure 9. Max. Safe Operating Area



TYPICAL TEST CIRCUIT

Gate Charge Test Circuit & Waveform



Resistive Switching Test Circuit & Waveform

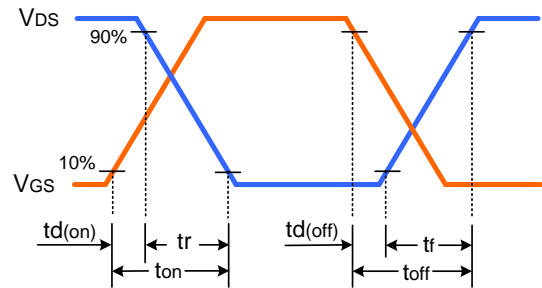
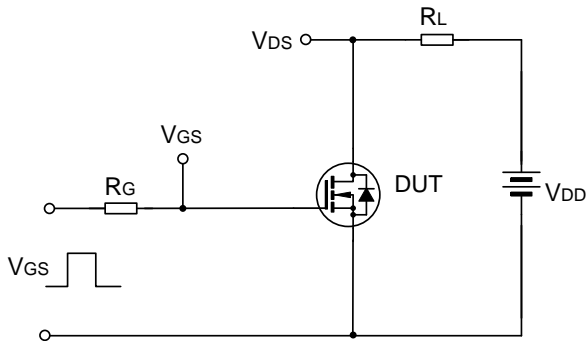

Unclamped Inductive Switching Test Circuit & Waveform

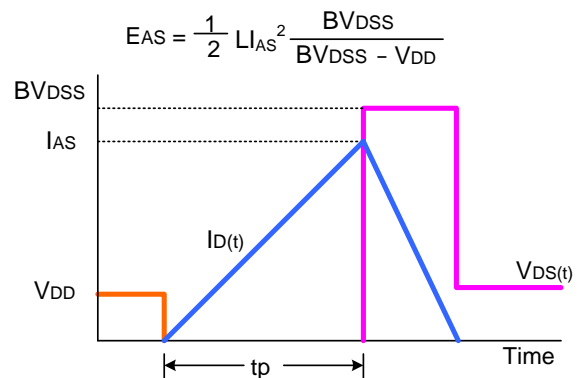
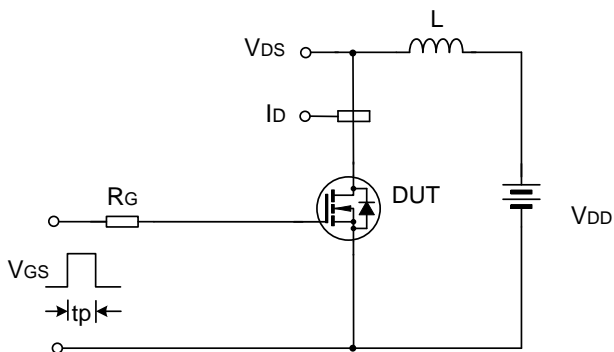

PACKAGE OUTLINE

TO-220-3L

UNIT: mm

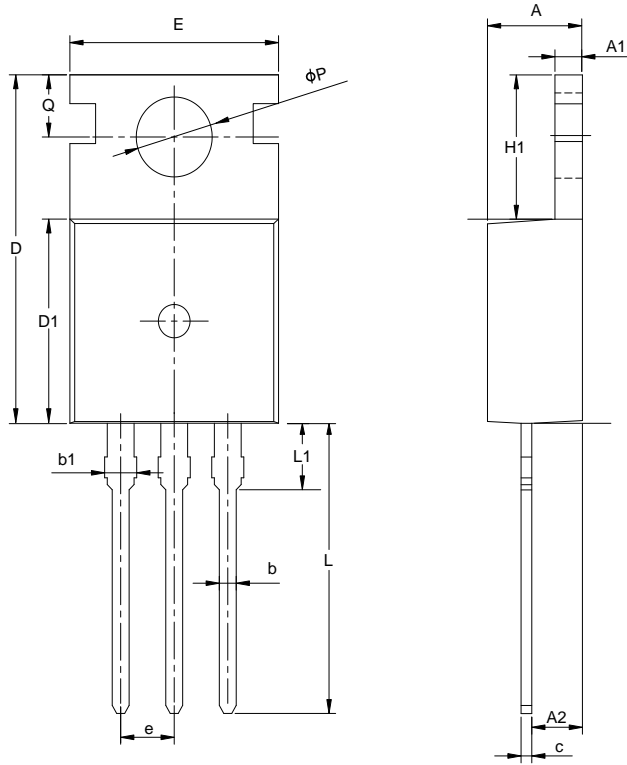

SYMBOL	MILLIMETER		
	MIN	NOM	MAX
A	4.30	4.50	4.70
A1	1.00	1.30	1.50
A2	1.80	2.40	2.80
b	0.60	0.80	1.00
b1	1.00	—	1.60
c	0.30	—	0.70
D	15.10	15.70	16.10
D1	8.10	9.20	10.00
E	9.60	9.90	10.40
e	2.54BSC		
H1	6.10	6.50	7.00
L	12.60	13.08	13.60
L1	—	—	3.95
ϕP	3.40	3.70	3.90
Q	2.60	—	3.20

TO-263-2L

UNIT: mm

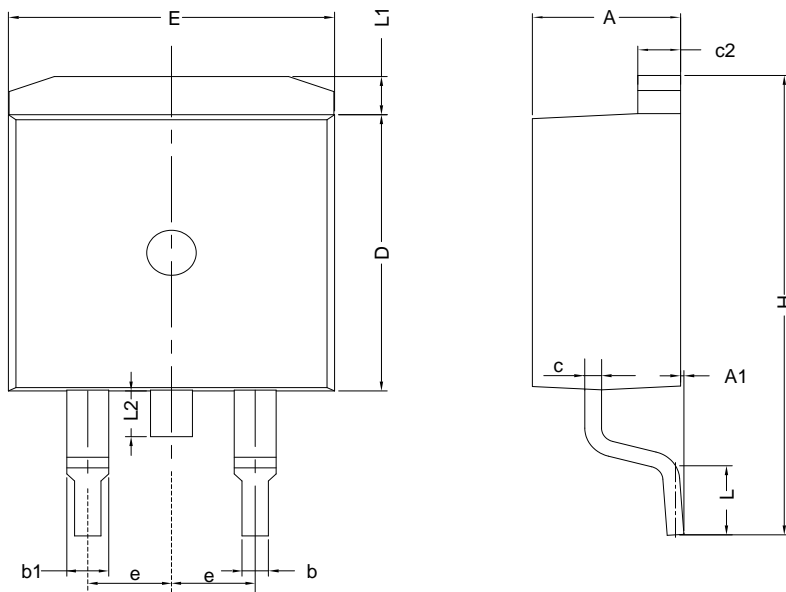

SYMBOL	MILLIMETER		
	MIN	NOM	MAX
A	4.30	4.57	4.72
A1	0	0.10	0.25
b	0.71	0.81	0.91
b1	1.17	—	1.50
c	0.30	—	0.60
c2	1.17	1.27	1.37
D	8.50	—	9.35
E	9.80	—	10.45
e	2.54BSC		
H	14.70	—	15.75
L	2.00	2.30	2.74
L1	1.12	1.27	1.42
L2	—	—	1.75

PACKAGE OUTLINE(CONTINUED)

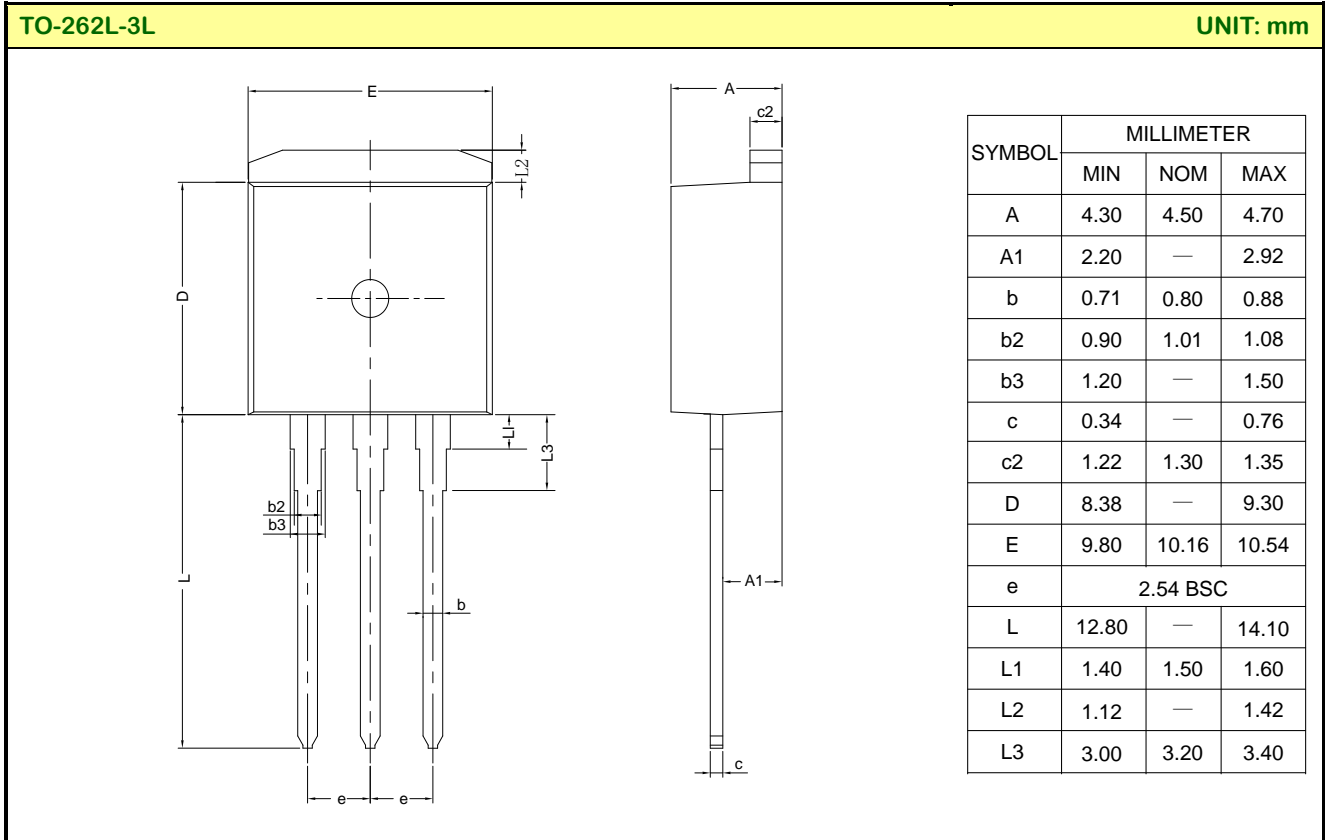

Important notice:

1. The instructions are subject to change without notice!
2. Customers should obtain the latest relevant information before placing orders and should verify that such information is complete and current. Please read the instructions carefully before using our products, including the circuit operation precautions.
3. Our products are consumer electronic products or the other civil electronic products.
4. When using our products, please do not exceed the maximum rating of the products, otherwise the reliability of the whole machine will be affected. There is a certain possibility of failure or malfunction of any semiconductor product under specific conditions. The buyer is responsible for complying with safety standards and taking safety measures when using our products for system design, sample and whole machine manufacturing, so as to avoid potential failure risk that may cause personal injury or property loss.
5. It is strongly recommended to identify the trademark when buying our products. Please contact us if there is any question.
6. Product promotion is endless, our company will wholeheartedly provide customers with better products!
7. Website: <http://www.silan.com.cn>

Part No.: **SVG105R4NT(S)(KL)** Document Type: **Datasheet**
Copyright: **HANGZHOU SILAN MICROELECTRONICS CO.,LTD** Website: **<http://www.silan.com.cn>**

Rev.: **1.2**

Revision History:

1. Add package of TO-262L-3L
 2. Update package outline of TO-263-2L
-

Rev.: **1.1**

Revision History:

1. Add TO-263-2L
-

Rev.: **1.0**

Revision History:

1. First release
-