



Power Your Critical Mission Today

SVRME28 Series

SPACE QUALIFIED HYBRID EMI FILTERS



SVRME Series EMI Filter

Models Available

Input: 28 V nominal

10 A output

Qualified to MIL-PRF-38534 Class H and Class K

Design for TOR Compliance

1.0 DESCRIPTION

The SVRME is specifically designed for use with the SVR series DC-DC converters in the harsh radiation environment of space applications. The SVRME design is fully passive, giving a strong resistance to radiation degradation. Performance is guaranteed through extensive circuit worst-case analysis and designed in accordance with Aerospace TOR requirements.

The SVRME Series of EMI filters is suited for use in low Earth orbit (LEO), medium Earth orbit (MEO), geostationary orbit (GEO), deep space, and launch vehicle programs.

1.1 FEATURES

- Up to 10 A maximum current
- High reliability
- Wide input voltage range: 0 to 37.5 V
- High input transient voltage: 50 V for 1 second
- 40 dB minimum attenuation at 500 kHz
- Continuous operation over full military temperature range of -55 °C to +125 °C with no power derating
- One module filters the emissions of multiple SVR Series DC-DC converters

1.2 SPACE LEVEL CHARACTERIZATIONS

- Fully passive design is immune to degradation from radiation
- Worst-case analysis, stress, radiation, reliability reports available

1.3 MANUFACTURING AND COMPLIANCE

- Qualified to MIL-PRF-38534 Class H and Class K, DLA Drawing # [13009](#)
- Available compliant to MIL-HDBK-1547 and Aerospace TOR component level element evaluation
- MIL-PRF-38534 element evaluated components
- MIL-STD-461C/D/E/F requirements for conducted emissions
- Manufactured in a MIL-PRF-38534 Class H and Class K facility
- MIL-STD-883
- ISO-9001

1.4 PACKAGING

- Low-profile: 3.005" x 1.505" x 0.400"
- Max weight: 91 g
- Industry standard pinout
- Precision seam-welded hermetic metal case

1.5 SIMILAR PRODUCTS AND ACCESSORIES

- [DVME](#) 15 A EMI filter for military/avionics applications
- Custom versions available
- [SVR Series](#) DC-DC converters

Products and reports described in this datasheet are subject to all export license restrictions and regulations which may include but are not limited to ITAR (International Traffic in Arms Regulations) and the Export Administration and Foreign Assets Control Regulations. Further restrictions may apply. Contact VPT sales for details.

2.0 DIAGRAMS

2.1 BLOCK DIAGRAM

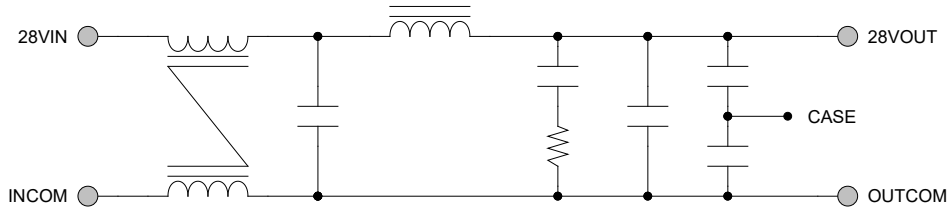

2.2 CONNECTION DIAGRAM

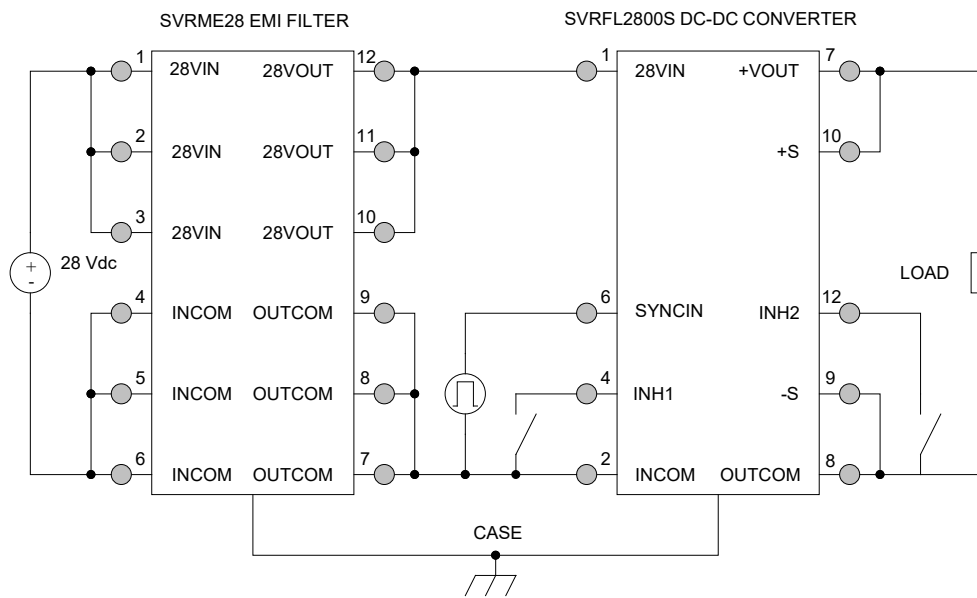

3.0 SPECIFICATIONS

3.1 ABSOLUTE MAXIMUM RATING

Absolute Maximum Ratings

Input Voltage (Continuous):	-0.5 V to 37.5 V	Operating Temperature (Full Load):	-55 °C to +125 °C
Input Voltage (Transient, 1 second):	-0.5 V to 50 V	Storage Temperature:	-65 °C to +150 °C
		Lead Solder Temperature (10 seconds):	300 °C

3.2 PERFORMANCE SPECIFICATIONS

Tcase = -55 °C to +125 °C, Vin = +28 V ± 5%, Full Load, Unless Otherwise Specified

Parameter	Conditions ²	SVRME28			Units
		Min	Typ	Max	
INPUT					
Voltage	Continuous	0	28	37.5	V
	Transient ¹ , 1 sec	-	-	50	V
OUTPUT STATIC					
Voltage ¹		Vout = Vin – (Iin x RDC)			V
Current		0	-	10.0	A
GENERAL					
DC Resistance		-	-	90	mΩ
Power Dissipation ¹		-	-	9.0	W
Noise Rejection	f = 500 kHz	40	-	-	dB
Capacitance	Any pin to case	60	-	100	nF
Isolation	Any pin to case, 500 VDC	100	-	-	MΩ
Weight	Standard package option	-	-	91	g
MTBF (MIL-HDBK-217F)	SF, Class K @ Tcase= 55 °C	-	58.4	-	MHr

1. Verified by qualification testing
2. End-of-Life performance includes aging and radiation degradation and is within standard limits except where noted
3. Correction factor of 0.12 added to ceramic capacitors

4.0 MECHANICAL OUTLINES AND PINOUT

Standard Package Option:

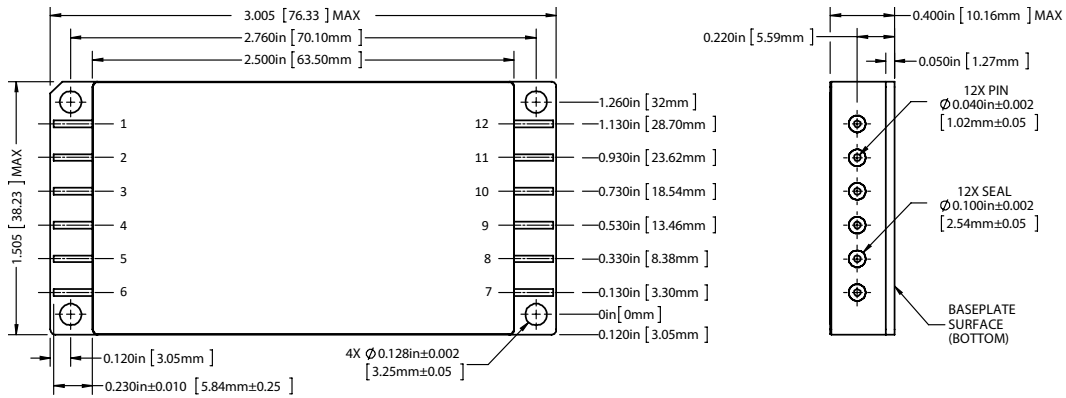

1. Tolerances are +0.005" unless otherwise stated
2. Case temperature is measured on the center of the baseplate surface
3. Mounting holes are not threaded. Recommended fastener is 4-40
4. Materials: Case (Steel, gold over nickel plated); Cover (Kovar, nickel plated); Pin (Copper-cored alloy 52, gold over nickel plated); Pin Seals (Glass)

Pin	Function	Pin	Function	Pin	Function	Pin	Function
1	28VIN	4	INCOM	7	OUTCOM	10	28VOUT
2	28VIN	5	INCOM	8	OUTCOM	11	28VOUT
3	28VIN	6	INCOM	9	OUTCOM	12	28VOUT

4.0 MECHANICAL OUTLINES AND PINOUT (CONTINUED)

Optional Side-Flanged Package:

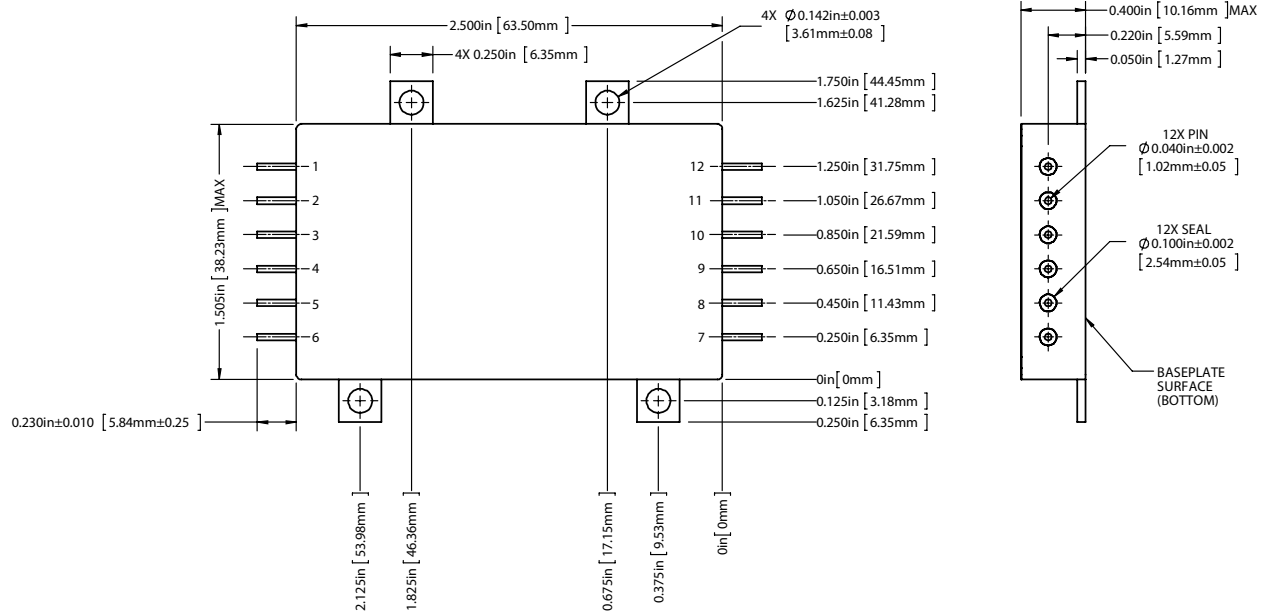

1. Tolerances are +0.005" unless otherwise stated
2. Case temperature is measured on the center of the baseplate surface
3. Mounting holes are not threaded. Recommended fastener is 4-40
4. Materials: Case (Steel, gold over nickel plated); Cover (Kovar, nickel plated); Pin (Copper-cored alloy 52, gold over nickel plated); Pin Seals (Glass)

Pin	Function	Pin	Function	Pin	Function	Pin	Function
1	28VIN	4	INCOM	7	OUTCOM	10	28VOUT
2	28VIN	5	INCOM	8	OUTCOM	11	28VOUT
3	28VIN	6	INCOM	9	OUTCOM	12	28VOUT

5.0 ENVIRONMENTAL SCREENING

100% tested per MIL-STD-883 as referenced to MIL-PRF-38534.

Contact sales for more information concerning additional environmental screening and testing options. VPT Inc. reserves the right to ship higher screened or SMD products to meet orders for lower screening levels at our sole discretion unless specifically forbidden by customer contract.

Test	MIL-STD-883 Test Method, Condition	/H+ (Class H + PIND)	/K (Class K)	/EM (Engineering Model) Non-QML ^{1,6}
Internal Visual	TM2010, TM2017, TM2032 (MIL-STD-750, TM2072, TM2073)	•	•	•
Temperature Cycling	TM1010, Condition C	•	•	
Constant Acceleration	TM2001, 3000g, Y1 Direction	•	•	
PIND ³	TM2020, Condition A	• ²	•	
Pre Burn-In Electrical	100% at 25 °C		•	
Burn-In	TM1015, 320 hrs., 125 °C		•	
	TM1015, 160 hrs., 125 °C	•		
	24 hrs., 125 °C			•
Final Electrical	MIL-PRF-38534, Group A ⁴	•	•	
	100% at 25 °C			•
Hermeticity (Seal)	TM1014, Fine Leak, Condition A2 or B1	•	•	
	TM1014, Gross Leak, Condition C or B2	•	•	
	Dip (1x10 ⁻³)			•
Radiography ⁵	TM2012		•	
External Visual	TM2009	•	•	•

1. Non-QML products may not meet all requirements of MIL-PRF-38534
2. Not required per MIL-PRF-38534. Test performed for additional product quality assurance
3. PIND test Certificate of Compliance included in product shipment

4. 100% R&R testing with all test data included in product shipment
5. Radiographic test Certificate of Compliance and film(s) or data CD included in product shipment
6. Engineering models utilize only the screening specified and are not considered compliant for flight use

6.0 STANDARD MICROCIRCUIT DRAWING (SMD) NUMBERS

DLA Drawing Number	SVRME Series Similar Part Number
13009-01HXC	SVRME28/H+
13009-01HXA	SVRME28/H+-E
13009-01HYC	SVRME28F/H+
13009-01HYA	SVRME28F/H+-E
13009-01KXC	SVRME28/K
13009-01KXA	SVRME28/K-E
13009-01KYC	SVRME28F/K
13009-01KYA	SVRME28F/K-E

Do not use the SVRME28 Series similar part number for SMD product acquisition. It is listed for reference only. For exact specifications for the SMD product, refer to the SMD drawing. SMDs can be downloaded from the DLA Land and Maritime (Previously known as DSCC) website at <http://www.dsccl.dla.mil/programs/smcr/>. The SMD number listed above represents the Federal Stock Class, Device Type, Device Class Designator, Case Outline, Lead Finish and RHA Designator (where applicable). Please reference the SMD for other screening levels, lead finishes, and radiation levels. All SMD products are marked with a “Q” on the cover as specified by the QML certification mark requirement of MIL-PRF-38534.

7.0 ORDERING INFORMATION

SVRME	28	F	/K	-	XXX
1	2	3	4		5

(1) Product Series	(2) Nominal Input Voltage	(3) Package Option	(4) Screening Code ^{1,2,3}	(5) Additional Screening Code
SVRME	28 28 Volts	(None) Standard F Side-Flanged	/EM Engineering Model /H+ Class H + PIND /K Class K	Contact Sales

- 1 Contact the VPT Sales Department for availability of Class H (/H) or Class K (/K) qualified products
- 2 VPT Inc. reserves the right to ship higher screened or SMD products to meet lower screened orders at our sole discretion unless specifically forbidden by customer contract.
- 3 Engineering models utilize only the standard screening specified and are not considered compliant for flight use. These models are intended for low volume engineering characterization. The customer must place the following statement on each line item of their purchase order(s) for /EM units when ordering engineering models:

“(Customer Name) acknowledges that the /EM unit listed in this line item is not permitted for flight use and will be used for engineering characterization only.”

Please contact your sales representative or the VPT Inc. Sales Department for more information concerning additional environmental screening and testing, different input voltage, output voltage, power requirements, source inspection, and/or special element evaluation for space or other higher quality applications.

8.0 CONTACT INFORMATION

To request a quotation or place orders please contact your sales representative or the VPT, Inc. Sales Department at:

Phone: (425) 353-3010
Fax: (425) 353-4030
E-mail: vptsales@vptpower.com

All information contained in this datasheet is believed to be accurate, however, no responsibility is assumed for possible errors or omissions. The products or specifications contained herein are subject to change without notice.

9.0 ADDITIONAL INFORMATION

Visit the VPT website for additional technical resources, including:

[Product Catalogs](#)



[Technical Video Labs](#)



[Application Notes and White Papers](#)

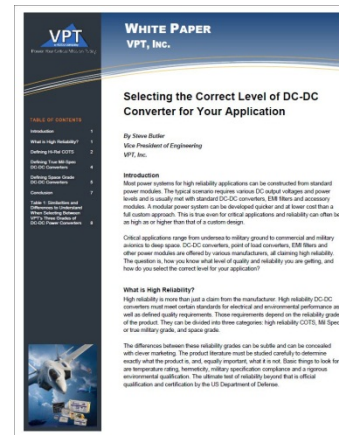

Additional Products For [Avionics/Military](#), [Hi-Rel COTS](#), and [Space Applications](#)

