

45A, 30V N-CHANNEL MOSFET

DESCRIPTION

The SVT03100NL3 is an N-channel enhancement mode power MOS field effect transistor which is produced using Silan's LVMOS technology. The improved process and cell structure have been especially tailored to minimize on-state resistance, provide superior switching performance.

This device is widely used in the fields of uninterruptible power supplies and power management of inverter systems.

FEATURES

- ◆ 45A, 30V, $R_{DS(on)(typ.)}=8.5m\Omega@V_{GS}=10V$
- ◆ Low gate charge
- ◆ Low Crss
- ◆ Fast switching
- ◆ Improved dv/dt capability

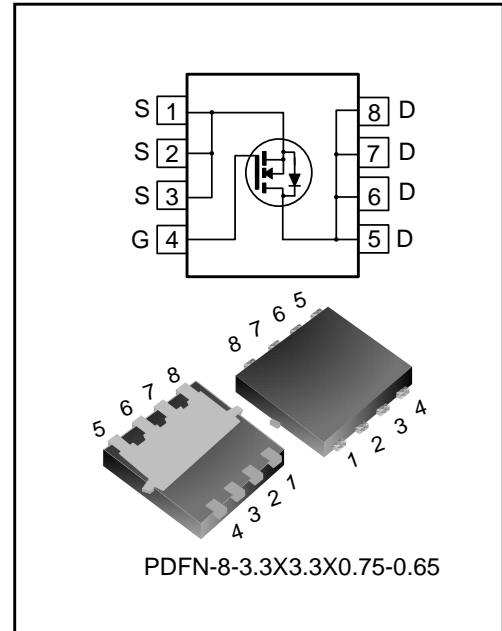

ORDERING INFORMATION

Part No.	Package	Marking	Hazardous Substance Control	Packing Type
SVT03100NL3TR	PDFN-8-3.3x3.3x0.75-0.65	0310	Halogen free	Tape&Reel

ABSOLUTE MAXIMUM RATINGS (UNLESS OTHERWISE NOTED, T_A=25°C)

Characteristics		Symbol	Ratings	Unit
Drain-Source Voltage		V _{DS}	30	V
Gate-Source Voltage		V _{GS}	±20	V
Drain Current	T _C =25°C	I _D	45	A
	T _C =100°C		29	
Drain Current Pulsed		I _{DM}	180	A
Power Dissipation (T _C =25°C) -Derate above 25°C		P _D	32	W
			0.26	W/°C
Single Pulsed Avalanche Energy (Note 1)		E _{AS}	85	mJ
Operation Junction Temperature Range		T _J	-55~+150	°C
Storage Temperature Range		T _{stg}	-55~+150	°C

THERMAL CHARACTERISTICS

Characteristics	Symbol	Ratings	Unit
Thermal Resistance, Junction-to-Case	R _{θJC}	3.9	°C/W
Thermal Resistance, Junction-to-Ambient	R _{θJA}	45	°C/W

ELECTRICAL CHARACTERISTICS (UNLESS OTHERWISE NOTED, T_J=25°C)

Characteristics	Symbol	Test conditions	Min.	Typ.	Max.	Unit
Drain-Source Breakdown Voltage	BV _{DSS}	V _{GS} =0V, I _D =250μA	30	--	--	V
Drain-Source Leakage Current	I _{DSS}	V _{DS} =30V, V _{GS} =0V	--	--	1.0	μA
Gate-Source Leakage Current	I _{GSS}	V _{GS} =±20V, V _{DS} =0V	--	--	±100	nA
Gate Threshold Voltage	V _{GS(th)}	V _{GS} =V _{DS} , I _D =250μA	1.0	--	3.0	V
Static Drain- Source On State Resistance	R _{DS(on)}	V _{GS} =10V, I _D =15A	--	8.5	10	mΩ
		V _{GS} =4.5V, I _D =15A	--	12	15	mΩ
Gate Resistance	R _G	f=1MHz	--	5.2	--	Ω
Input Capacitance	C _{iss}	f=1MHz, V _{GS} =0V, V _{DS} =30V	--	1208	--	pF
Output Capacitance	C _{oss}		--	145	--	
Reverse Transfer Capacitance	C _{rss}		--	117	--	
Turn-on Delay Time	t _{d(on)}	V _{DD} =20V, V _{GS} =10V, R _G =6Ω, I _D =15A (Notes 2,3)	--	4.7	--	ns
Turn-on Rise Time	t _r		--	34	--	
Turn-off Delay Time	t _{d(off)}		--	40	--	
Turn-off Fall Time	t _f		--	16	--	
Total Gate Charge	Q _g	V _{DD} =24V, V _{GS} =10V, I _D =15A (Notes 2,3)	--	26	--	nC
Gate-Source Charge	Q _{gs}		--	5.0	--	
Gate-Drain Charge	Q _{gd}		--	5.5	--	

SOURCE-DRAIN DIODE RATINGS AND CHARACTERISTICS

Characteristics	Symbol	Test conditions	Min.	Typ.	Max.	Unit
Continuous Source Current	I_S	Integral Reverse P-N Junction	--	--	45	A
Pulsed Source Current	I_{SM}	Diode in the MOSFET	--	--	180	
Diode Forward Voltage	V_{SD}	$I_S=15A, V_{GS}=0V$	--	--	1.4	V
Reverse Recovery Time	T_{rr}	$I_S=15A, V_{GS}=0V,$	--	13	--	ns
Reverse Recovery Charge	Q_{rr}	$dI/dt=100A/\mu s$ (Note 2)	--	0.005	--	μC

Notes:

1. $L=0.5mH, V_{DD}=15V, V_G=10V, R_G=25\Omega$, starting $T_J=25^\circ C$;
2. Pulse Test: Pulse width $\leq 300\mu s$, Duty cycle $\leq 2\%$;
3. Essentially independent of operating temperature.

TYPICAL CHARACTERISTICS

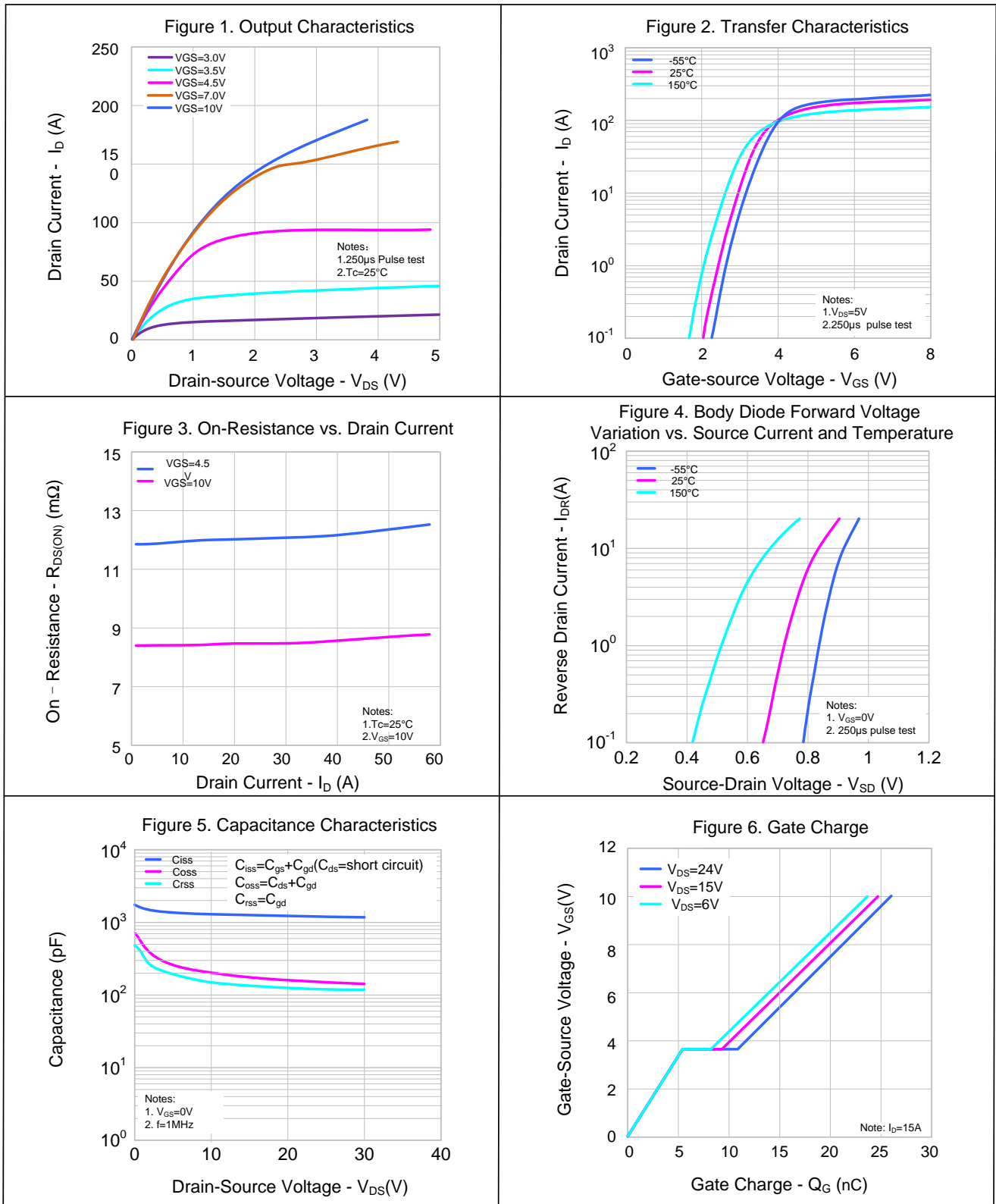

TYPICAL CHARACTERISTICS (CONTINUED)

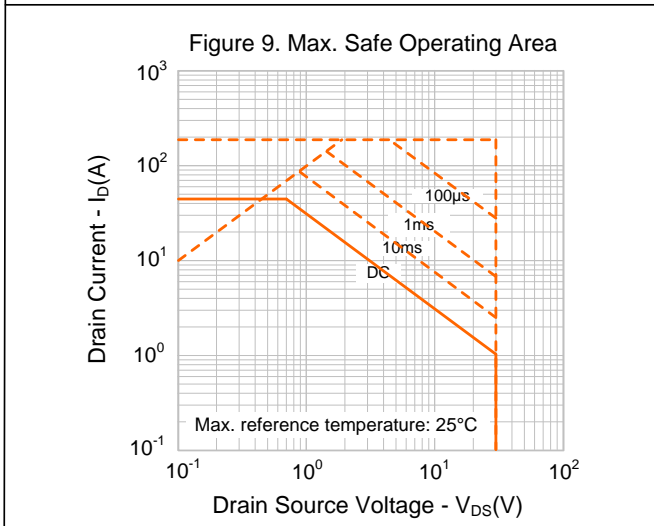
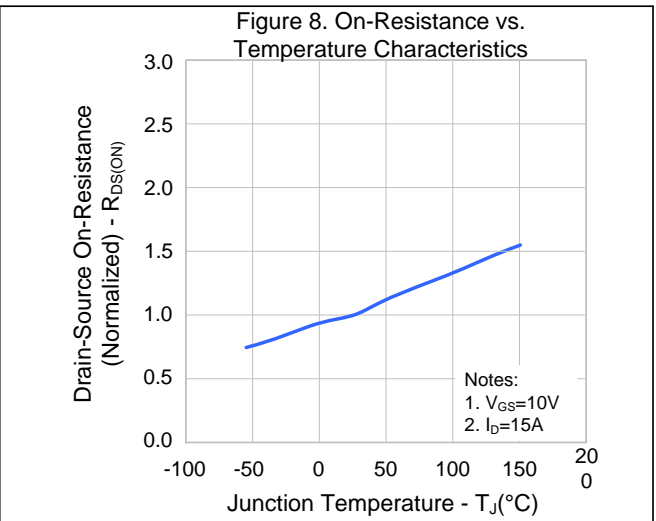
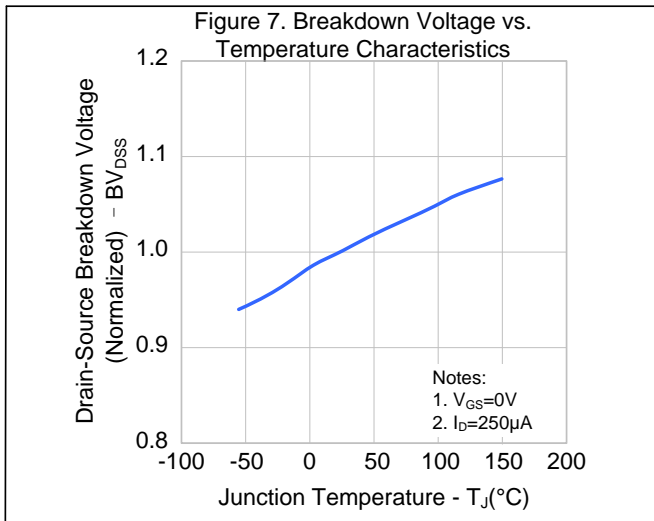

TYPICAL TEST CIRCUIT

Gate Charge Test Circuit & Waveform

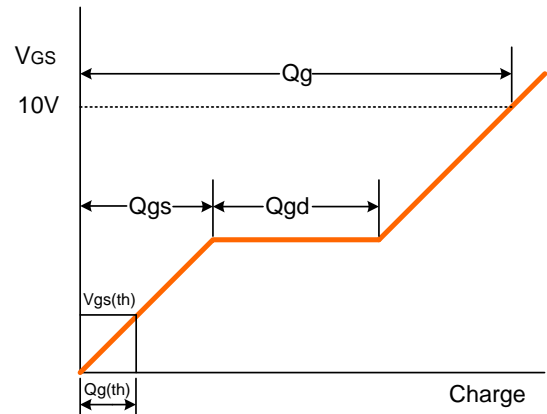
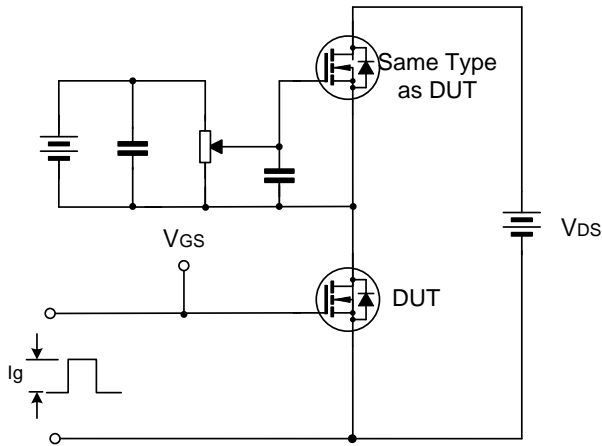

Resistive Switching Test Circuit & Waveform

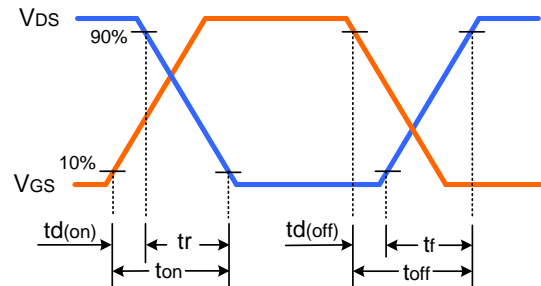
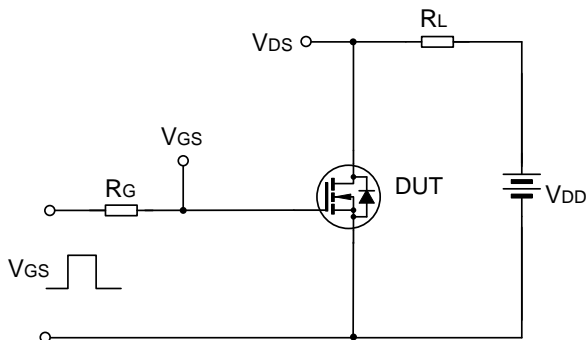

Unclamped Inductive Switching Test Circuit & Waveform

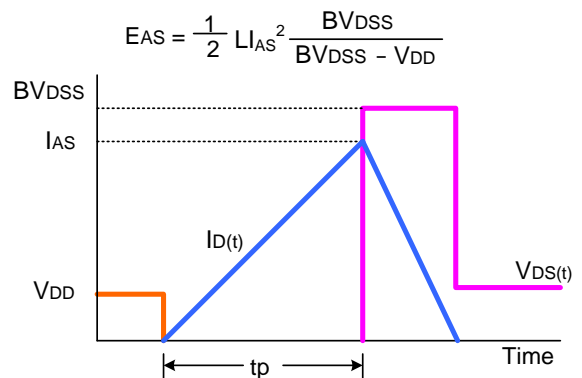
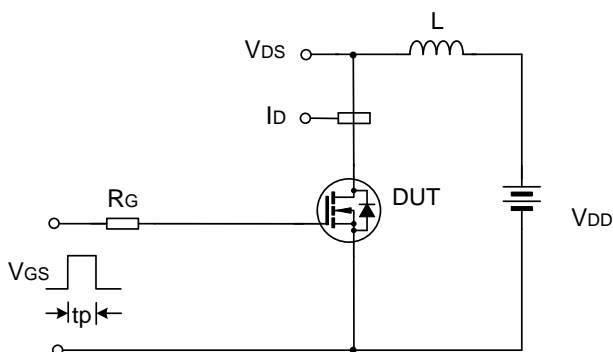

PACKAGE OUTLINE

PDFN-8-3.3x3.3x0.75-0.65

UNIT: mm

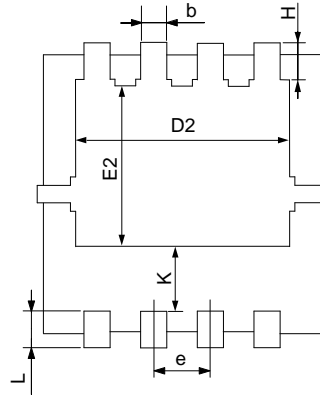
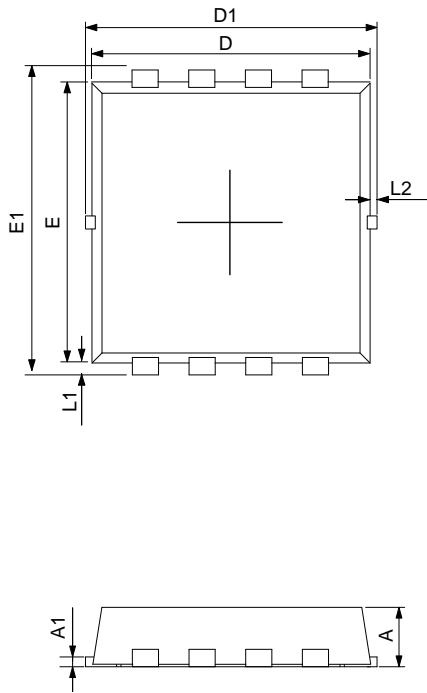

SYMBOL	MILLIMETER		
	MIN	NOM	MAX
A	0.70	0.80	0.90
A1	0.14	0.15	0.20
b	0.25	0.30	0.35
D	3.05	3.15	3.25
D1	3.10	3.30	3.50
D2	2.35	2.45	2.55
E	2.90	3.00	3.10
E1	3.10	3.30	3.50
E2	1.64	1.74	1.84
e	0.55	0.65	0.75
H	0.32	0.42	0.52
K	0.59	0.69	0.79
L	0.25	0.40	0.55
L1	0.10	0.15	0.20
L2	—	—	0.15

Important notice :

1. The instructions are subject to change without notice!
2. Customers should obtain the latest relevant information before placing orders and should verify that such information is complete and current. Please read the instructions carefully before using our products, including the circuit operation precautions.
3. Our products are consumer electronic products or the other civil electronic products.
4. When using our products, please do not exceed the maximum rating of the products, otherwise the reliability of the whole machine will be affected. There is a certain possibility of failure or malfunction of any semiconductor product under specific conditions. The buyer is responsible for complying with safety standards and taking safety measures when using our products for system design, sample and whole machine manufacturing, so as to avoid potential failure risk that may cause personal injury or property loss.
5. It is strongly recommended to identify the trademark when buying our products. Please contact us if there is any question.
6. Product promotion is endless, our company will wholeheartedly provide customers with better products!
7. Website: <http://www.silan.com.cn>

Part No.: SVT03100NL3 Document Type: Datasheet
Copyright: HANGZHOU SILAN MICROELECTRONICS CO.,LTD Website: <http://www.silan.com.cn>

Rev.: 1.2

Revision History:

1. Increase the $R_{DS(on)}$ when $V_{GS}=4.5V$
 2. Delete the nomenclature
 3. Update curve template and important notice
-

Rev.: 1.1

Revision History:

1. Update Electrical schematic
 2. Update important notice
-

Rev.: 1.0

Revision History:

1. First release
-
-