

SW05-0311

Features

- Integral TTL Driver
- Low DC Power Consumption
- Surface Mount Package
- Low Cost/High Performance
- 50 Ohm Nominal Impedance

Description

M/A-COM's SW05-0311 is a GaAs FET SPST absorptive switch with integral silicon ASIC driver. Packaged in a 16-lead ceramic surface mount package, this device offers excellent performance and repeatability from DC to 3 GHz while maintaining low power consumption. The SW05-0311 is ideally suited for use where fast speed, low power consumption and broadband applications are required.

CR-9

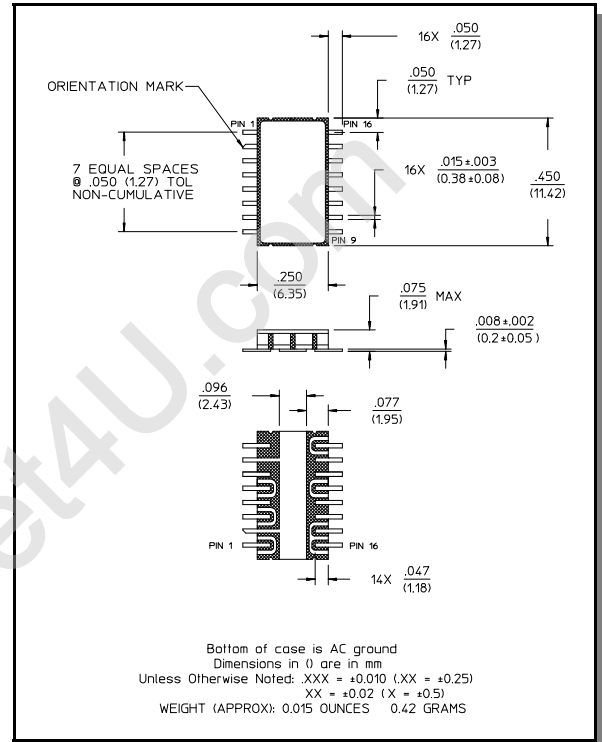

Electrical Specifications^{1,2} T_A = +25°C

Parameter	Test Conditions	Frequency	Units	Min	Typ	Max
Insertion Loss	—	DC - 3000 MHz	dB	—	1.0	1.3
		DC - 2000 MHz	dB	—	0.8	1.2
		DC - 1000 MHz	dB	—	0.7	1.0
		DC - 500 MHz	dB	—	0.6	0.8
VSWR	—	DC - 3000 MHz	Ratio	—	1.4:1	1.5:1
		DC - 2000 MHz	Ratio	—	1.3:1	1.4:1
		DC - 1000 MHz	Ratio	—	1.2:1	1.3:1
		DC - 500 MHz	Ratio	—	1.1:1	1.2:1
Isolation	—	DC - 3000 MHz	dB	25	29	—
		DC - 2000 MHz	dB	35	40	—
		DC - 1000 MHz	dB	35	60	—
		DC - 500 MHz	dB	65	70	—
Trise, Tfall	10% to 90%	—	ns	—	50	—
Ton, Toff	D1.3V CTL to 90% / 10%	—	ns	—	150	—
Transients	In-Band	—	mV	—	50	—
1 dB Compression	Input Power	0.05 GHz	dBm	—	+21	—
		0.5 GHz to 3 GHz	dBm	—	+27	—
IP2	Two-Tone Input Power up to +5 dBm	0.05 GHz	dBm	—	+62	—
		0.5 GHz to 3 GHz	dBm	—	+68	—
IP3	Two-Tone Input Power up to +5 dBm	0.05 GHz	dBm	—	+40	—
		0.5 GHz to 3 GHz	dBm	—	+46	—
Vin Low	0V to 0.8V	—	µA	—	—	1
Vin High	2.0V to 5.0V	—	µA	—	—	1

1. All specifications apply when operated with bias voltages of +5V for V_{cc} and -5V for V_{ee}.
 2. When DC blocks are used, a 10K ohm return to GND is required on the RFC port.

Electrical Specifications: $T_A = +25^\circ\text{C}$

Parameter	Test Conditions	Frequency	Units	Min	Typ	Max
Vcc	+5.0V \pm 10%	—	mA	—	—	1
Vee	-5.0V to -8.0V	—	mA	—	—	1

Pin Configuration

Pin No.	Function	Pin No.	Function
1	Vee	9	GND
2	GND	10	GND
3	GND	11	GND
4	GND	12	RF2
5	RF1	13	GND
6	GND	14	GND
7	GND	15	Vcc
8	GND	16	C1

Pin Configuration (Top View)

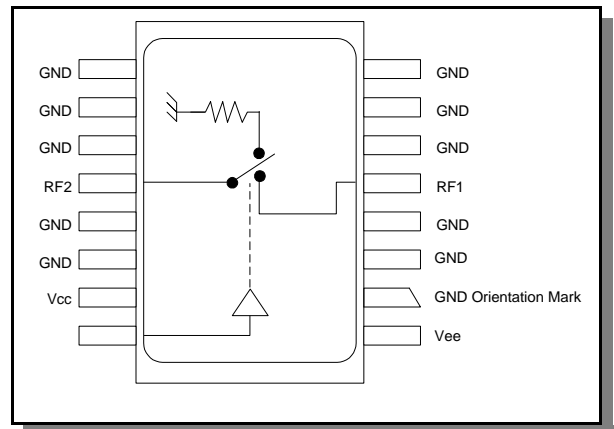

Absolute Maximum Ratings ³

Parameter	Absolute Maximum
Max Input Power 50 MHz 500 - 2000 MHz	+27 dBm +34 dBm
Supply Voltages Vcc Vee	+5.5V -8.5V
Control Voltage ⁴	-0.5V, to Vcc +0.5V
Operating Temperature	-40°C to +125°C
Storage Temperature	-65°C to +150°C

- 3. Operation of this device above any one of these parameters may cause permanent damage.
- 4. Standard CMOS TTL interface, latch-up will occur if logic signal is applied prior to power supply.

Truth Table

Control Input	Condition of Switch
C1	RF1 to RF2
LO	ON
HI	OFF

Specifications subject to change without notice.

- North America: Tel. (800) 366-2266
- Asia/Pacific: Tel.+81-44-844-8296, Fax +81-44-844-8298
- Europe: Tel. +44 (1344) 869 595, Fax+44 (1344) 300 020

Visit www.macom.com for additional data sheets and product information.

Typical Performance Curves

Insertion Loss vs. Frequency

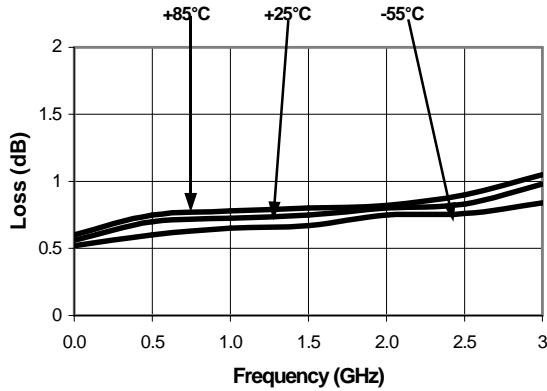

Isolation vs. Frequency

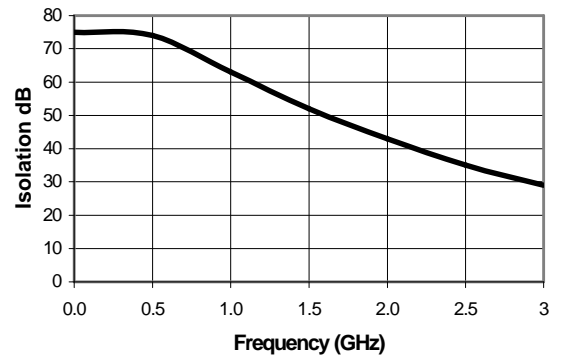

VSWR vs. Frequency

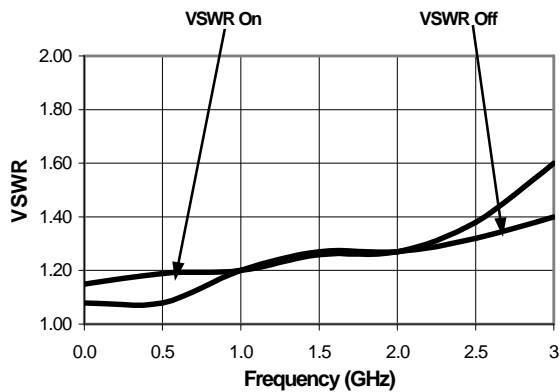

Ordering Information

Part Number	Package
SW05-0311	CR-9

Specifications subject to change without notice.

- North America: Tel. (800) 366-2266
- Asia/Pacific: Tel.+81-44-844-8296, Fax +81-44-844-8298
- Europe: Tel. +44 (1344) 869 595, Fax+44 (1344) 300 020

Visit www.macom.com for additional data sheets and product information.