

Service Manual

PIONEER
The Art of Entertainment

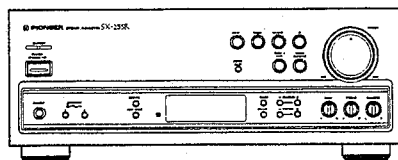

STEREO RECEIVER

SX-255R

SX-205

THIS MANUAL IS APPLICABLE TO THE FOLLOWING MODEL(S) AND TYPE(S).

Type	Model		Power Requirement	The voltage can be converted by the following method.
	SX-255R	SX-205		
KUXJ	○	○	AC120V	————
KCXJ	○	—	AC120V	————
SDXJ	—	○	AC110V/120-127V/230V/240V	With the voltage selector
YPWXJ	○	—	AC240V	————

CONTENTS

1. SAFETY INFORMATION.....	2	6. PCB PARTS LIST.....	23
2. CHECKING FOR PCB PATTERN OF MOTHER ASSY.....	3	7. ADJUSTMENTS	26
3. EXPLODED VIEWS, PACKING AND PARTS LIST.....	4	8. IC INFORMATION	28
4. BLOCK DIAGRAM.....	7	9. FL INFORMATION	30
5. SCHEMATIC AND PCB CONNECTION DIAGRAMS.....	8	10. FOR SX-255R/KCXJ, YPWXJ, SX-205/KUXJ AND SDXJ	31
		11. SPECIFICATIONS	34
		12. PANEL FACILITIES	35

PIONEER ELECTRONIC CORPORATION 4-1, Meguro 1-Chome, Meguro-ku, Tokyo 153, Japan

PIONEER ELECTRONICS SERVICE INC. P.O. Box 1760, Long Beach, CA 90801-1760, U.S.A.

PIONEER ELECTRONIC [EUROPE] N.V. Haven 1087 Keetberglaan 1, 9120 Melsele, Belgium

PIONEER ELECTRONICS ASIACENTRE PTE. LTD. 501 Orchard Road, #10-00 Lane Crawford Place, Singapore 0923

© **PIONEER ELECTRONIC CORPORATION** 1996

O-DFG JAN. 1996 Printed in Japan

SX-255R, SX-205

1. SAFETY INFORMATION

This service manual is intended for qualified service technicians; it is not meant for the casual do-it-yourselfer. Qualified technicians have the necessary test equipment and tools, and have been trained to properly and safely repair complex products such as those covered by this manual. Improperly performed repairs can adversely affect the safety and reliability of the product and may void the warranty. If you are not qualified to perform the repair of this product properly and safely, you should not risk trying to do so and refer the repair to a qualified service technician.



WARNING

Lead in solder used in this product is listed by the California Health and Welfare agency as a known reproductive toxicant which may cause birth defects or other reproductive harm (California Health & Safety Code, Section 25249.5).

When servicing or handling circuit boards and other components which contain lead in solder, avoid unprotected skin contact with the solder. Also, when soldering do not inhale any smoke or fumes produced.



NOTICE

(FOR CANADIAN MODEL ONLY)

Fuse symbols  (fast operating fuse) and/or  (slow operating fuse) on PCB indicate that replacement parts must be of identical designation.

REMARQUE

(POUR MODÈLE CANADIEN SEULEMENT)

Les symboles de fusible  (fusible de type rapide) et/ou  (fusible de type lent) sur CCI indiquent que les pièces de remplacement doivent avoir la même désignation.

(FOR USA MODEL ONLY)

1. SAFETY PRECAUTIONS

The following check should be performed for the continued protection of the customer and service technician.

LEAKAGE CURRENT CHECK

Measure leakage current to a known earth ground (water pipe, conduit, etc.) by connecting a leakage current tester such as Simpson Model 229-2 or equivalent between the earth ground and all exposed metal parts of the appliance (input/output terminals, screwheads, metal overlays, control shaft, etc.). Plug the AC line cord of the appliance directly into a 120V AC 60 Hz outlet and turn the AC power switch on. Any current measured must not exceed 0.5 mA.

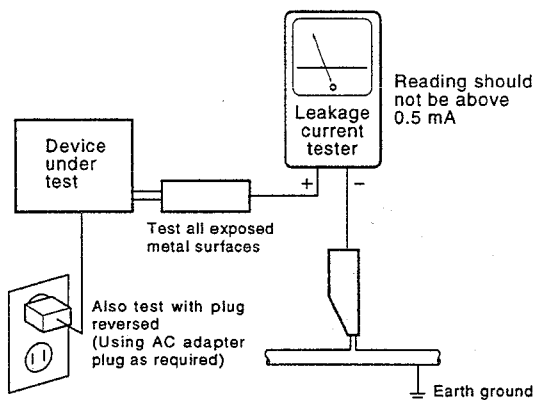

AC Leakage Test

ANY MEASUREMENTS NOT WITHIN THE LIMITS OUTLINED ABOVE ARE INDICATIVE OF A POTENTIAL SHOCK HAZARD AND MUST BE CORRECTED BEFORE RETURNING THE APPLIANCE TO THE CUSTOMER.

2. PRODUCT SAFETY NOTICE

Many electrical and mechanical parts in the appliance have special safety related characteristics. These are often not evident from visual inspection nor the protection afforded by them necessarily can be obtained by using replacement components rated for voltage, wattage, etc. Replacement parts which have these special safety characteristics are identified in this Service Manual.

Electrical components having such features are identified by marking with a  on the schematics and on the parts list in this Service Manual.

The use of a substitute replacement component which does not have the same safety characteristics as the PIONEER recommended replacement one, shown in the parts list in this Service Manual, may create shock, fire, or other hazards.

Product Safety is continuously under review and new instructions are issued from time to time. For the latest information, always consult the current PIONEER Service Manual. A subscription to, or additional copies of, PIONEER Service Manual may be obtained at a nominal charge from PIONEER.

2. CHECKING FOR PCB PATTERN OF MOTHER ASSY

1. Remove lower set screw ① at the center of the Chassis and Rear Panel.
2. Cut binder ② and remove.
3. Remove the three screws ③ fastening the MOTHER Assy, and the two screws ④ fastening the Radiator.
4. Grip the Radiator and Rear Panel, and lift up about 3 cm. Then, lift up the MOTHER Assy as shown in Fig. 2 so that it can be checked.

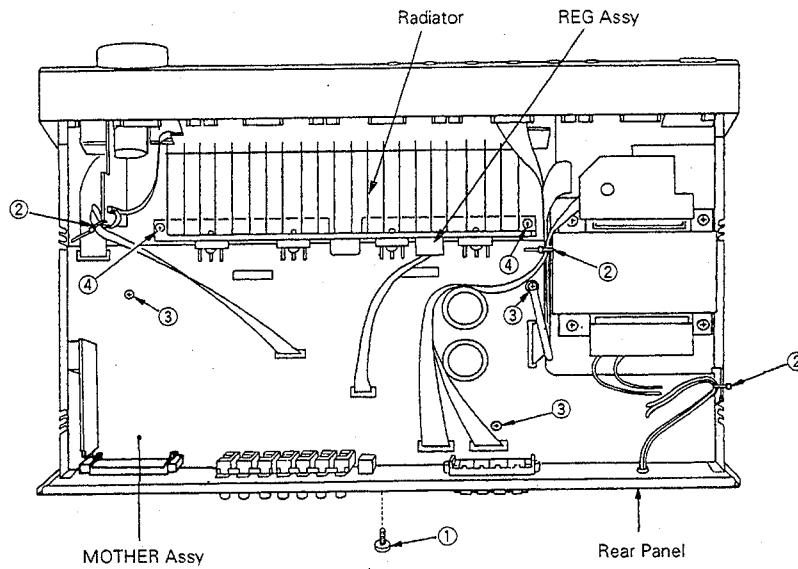

Fig. 1

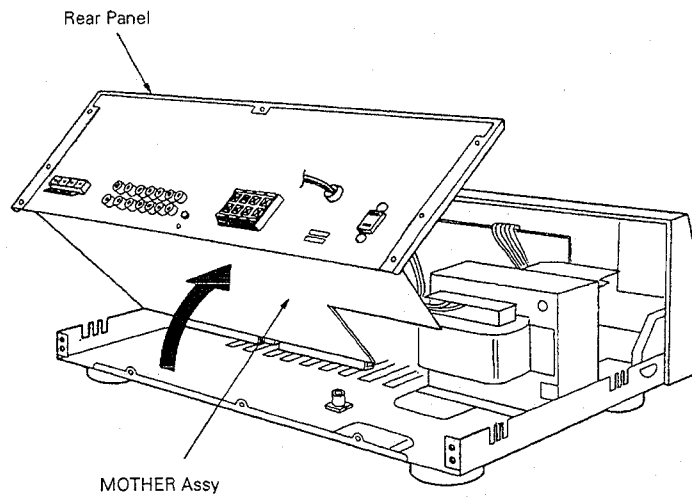

Fig. 2

SX-255R, SX-205

3. EXPLODED VIEWS, PACKING AND PARTS LIST

NOTES :

- Parts marked by "NSP" are generally unavailable because they are not in our Master Spare Parts List.
- The \triangle mark found on some component parts indicates the importance of the safety factor of the part. Therefore, when replacing, be sure to use parts of identical designation.
- Parts marked by "⊙" are not always kept in stock. Their delivery time may be longer than usual or they may be unavailable.

Parts List of Exterior and Packing (For SX-255R/KUXJ)

Mark	No.	Description	Parts No.	Mark	No.	Description	Parts No.
	1	FL Panel	AAK7239	NSP	46	PRIMARY Assy	AWZ8369
	2	Front Panel	AMB7331	NSP	47	BARRIER Assy	AWZ8371
\triangle	3	Transistor (Q1)	2SC5200		48	Screw (3×14)	ABA1194
\triangle	4	Transistor (Q2)	2SC5200		49	Screw	ABA7009
\triangle	5	Transistor (Q3)	2SA1943		50	Screw (3×8)	ABA7019
\triangle	6	Transistor (Q4)	2SA1943		51	Screw	BBZ30P200FMC
\triangle	7	Power Transformer (T1)	ATS7114		52	Screw	BBZ30P080FZK
\triangle	8	AC Power Cord	PDG1015		53	Screw	BCZ30P080FZK
\triangle	9	Fuse (6.3A, FU1)	REK1085		54	Screw	BPZ26P080FMC
	10			55	
\triangle	11	Fuse (1A, FU3)	REK1075		56	
\triangle	12	Fuse (1A, FU4)	REK1075		57	Remote Control Unit (CU-SX108)	AXD7085
NSP	13	Chassis	ANA1228	NSP	58	Battery (R6P, AA)	VEM-013
	14	Rear Panel	ANC7339		59	Loop Antenna	ATB7004
NSP	15	Radiator	ANH1458		60	FM Antenna	ADH1017
	16	Foot	AEC1505		61	Battery Cover	AZA7123
NSP	17	Binder	ZCA-BK1		62	
	18	PCB Support	AEC1581		63	Operating Instructions (English)	ARB7064
	19	Mica Sheet	AEE1014	NSP	64	Warranty Card	ARY1051
	20	Strain Relief	CM-22C		65	Sub Pad	AHA7051
NSP	21	Binder	RNE1277		66	Pad Side (A)	AHA7121
	22	PCB Mold	AMR2533		67	Pad Side (B)	AHA7122
	23			68	Packing Case	AHD7265
	24			69	Packing Sheet	AHG7026
	25	LED Lens	AAK2553				
	26					
	27	Name Plate	PAM1608				
	28	Round Knob S	AAB7083				
	29	Round Knob L	AAB7082				
	30	Push Button	AAD7282				
	31	Power Button	AAD2531				
	32	Hinge Button A	AAD7279				
	33	Hinge Button B	AAD7280				
	34	Function Button	AAD7281				
	35					
	36	Panel Holder	ANG7087				
	37	Bonnet Case	ANE7109				
	38	MOTHER Assy	AWZ8086				
	39	FL AND UCOM Assy	AWZ8090				
	40	SP SW. AND HP. Assy	AWZ8096				
	41	TRANS Assy	AWZ8097				
	42	REG Assy	AWZ8389				
	43	VOL. Assy	AWZ8092				
	44	POWER SW. Assy	AWZ8094				
	45	FM/AM TUNER FE MODULE	AXQ1002				

● Exterior

NOTE : Screws adjacent to ▼ mark on the product are used for disassembly.

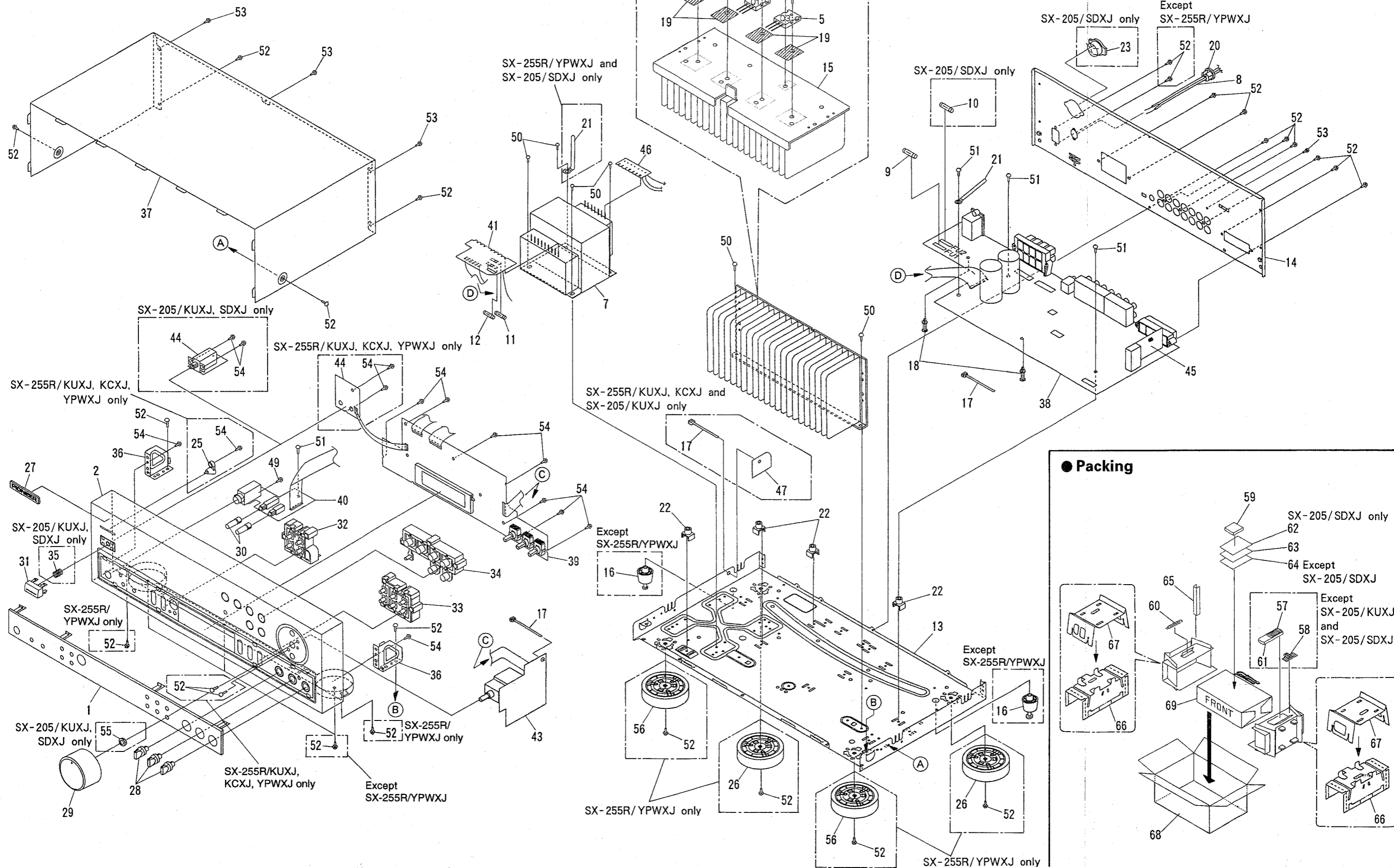

● Packing

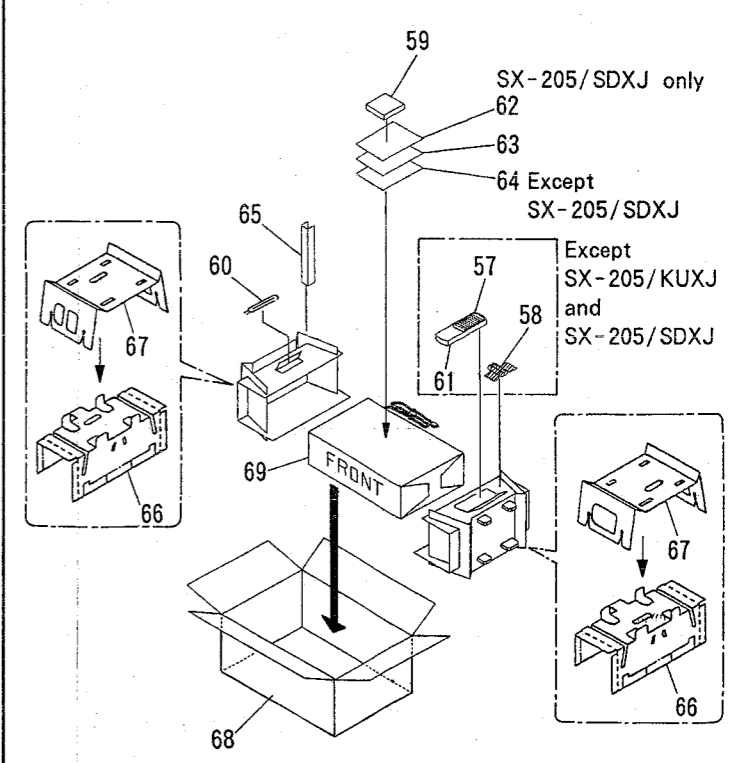

SX-255R, SX-205

4. BLOCK DIAGRAM

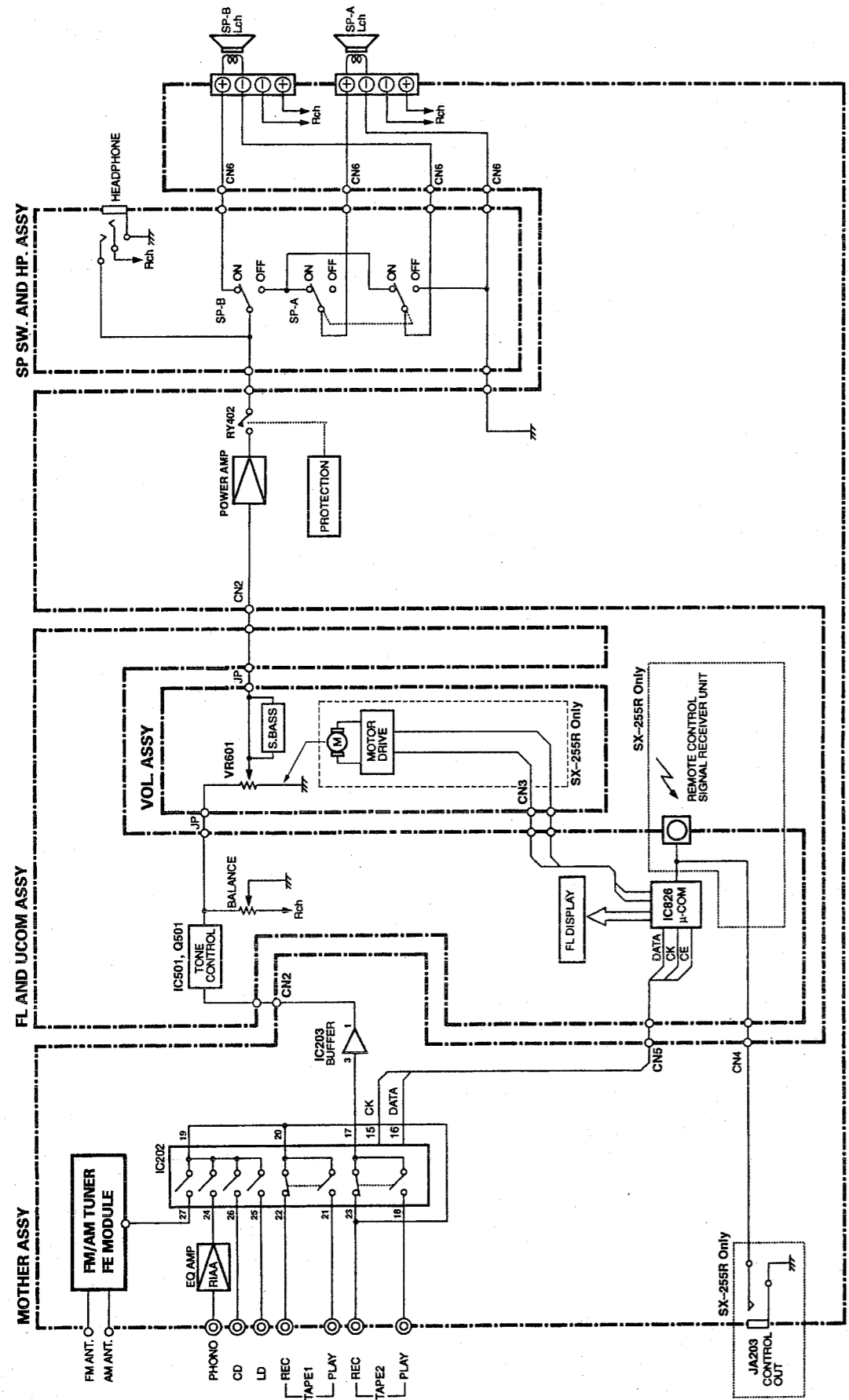

5. SCHEMATIC AND PCB CONNECTION DIAGRAMS
5.1 OVERALL SCHEMATIC DIAGRAM

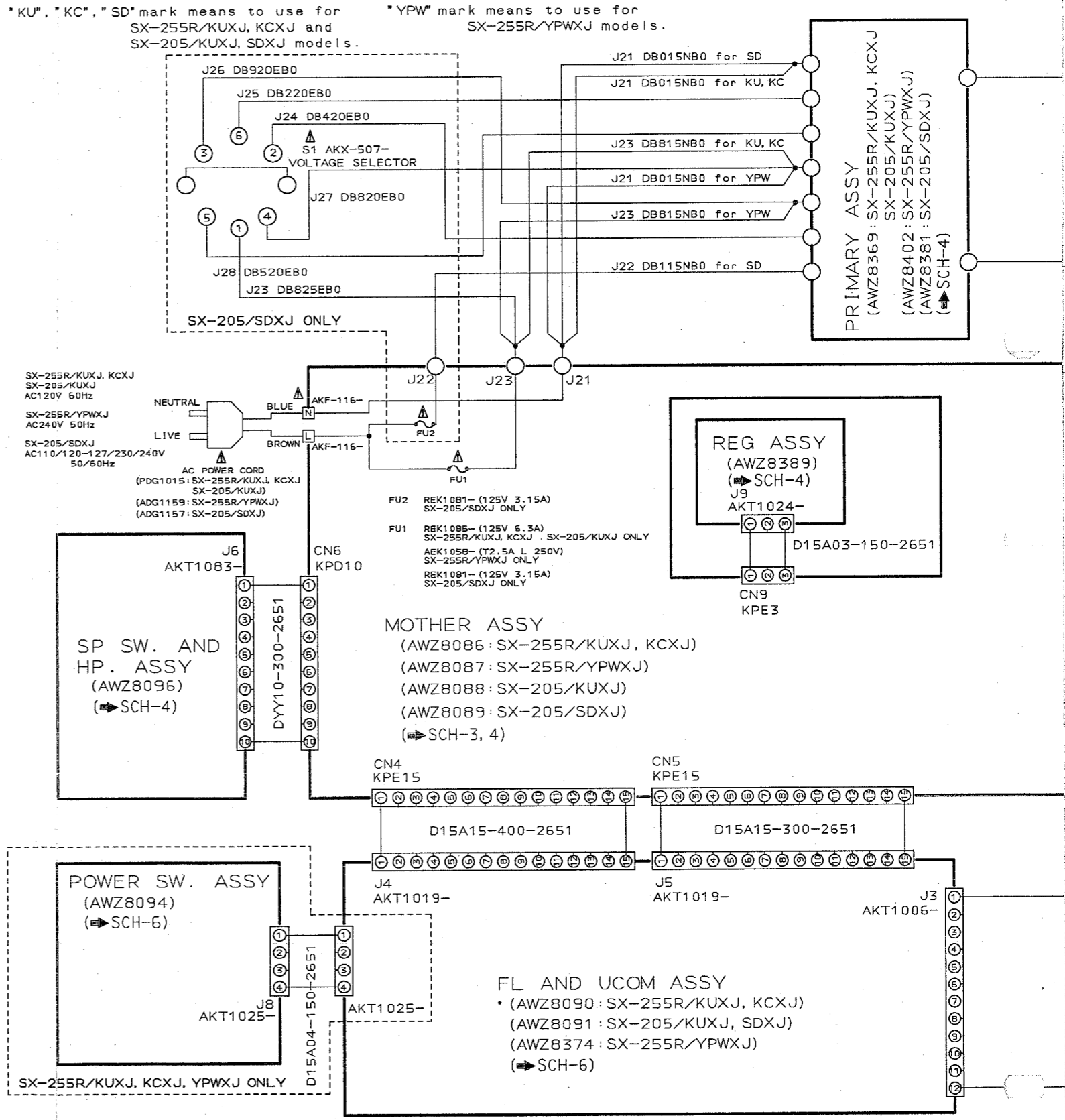

SCH-1 OVERALL SCHEMATIC DIAGRAM

SX-255R, SX-205

● NOTE FOR FUSE REPLACEMENT

CAUTION - FOR CONTINUED PROTECTION AGAINST RISK OF FIRE, REPLACE ONLY WITH SAME TYPE AND RATINGS ONLY.

SCH-1

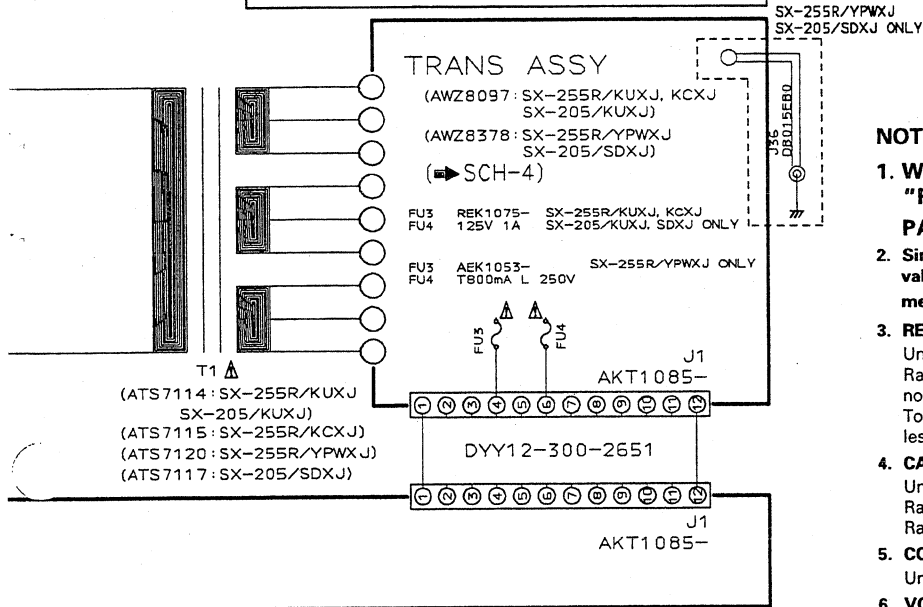

NOTE FOR SCHEMATIC DIAGRAMS (TYPE 1A)

1. When ordering service parts, be sure to refer to "PARTS LIST of EXPLODED VIEWS" or "PCB PARTS LIST".

2. Since these are basic circuits, some parts of them or the values of some components may be changed for improvement.

3. RESISTORS:
 Unit: k:Ω, M:MΩ, or Ω unless otherwise noted.
 Rated power: 1/4W, 1/6W, 1/8W, 1/10W unless otherwise noted.
 Tolerance: (F): ±1%, (G): ±2%, (K): ±10%, (M): ±20% or ±5% unless otherwise noted.

4. CAPACITORS:
 Unit: p:pF or μF unless otherwise noted.
 Ratings: capacitor (μF) / voltage (V) unless otherwise noted.
 Rated voltage: 50V except for electrolytic capacitors.

5. COILS:
 Unit: m:mH or μH unless otherwise noted.

6. VOLTAGE AND CURRENT:
 : SIGNAL voltage at rated output.
 or :
 DC voltage (V) at no input signal unless otherwise noted.
 Value in () is DC voltage at rated power.
 mA or mA :
 DC current at no input signal unless otherwise noted.

7. OTHERS:
 ● ⊙ or ● ⊙ : Adjusting point.
 ● ◀ : Measurement point.
 ● The Δ mark found on some components parts indicates the importance of the safety factor of the parts. Therefore, when replacing, be sure to use parts of identical designation.

8. SCH-□ ON THE SCHEMATIC DIAGRAM:
 ● SCH-□ indicates the drawing number of the schematic diagram. (SCH stands for schematic diagram.)

9. SWITCHES (Underline indicates switch position):
 Voltage Selector (SX-205/SDXJ only)
 AC110V/120-127V/230V/240V

MOTHER Assy
 S401 9k/10k (SX-205/SDXJ only)

FL AND UCOM ASSY
 S826 STATION UP
 S827 STATION DOWN
 S828 CLASS
 S829 MPX MODE
 S830 FREQUENCY UP
 S831 FREQUENCY DOWN
 S832 BAND
 S833 PHONO
 S834 TAPE 2
 S835 TAPE 1/VCR
 S836 S. BASS
 S837 MEMORY
 S838 CD
 S839 LD/DVD
 S840 TUNER

POWER SW. Assy
 S876 POWER STANDBY/ON (for SX-255R)
 S401 POWER (for SX-205)

SP SW. AND HP. Assy
 S701 SPEAKER A ON/OFF
 S702 SPEAKER B ON/OFF

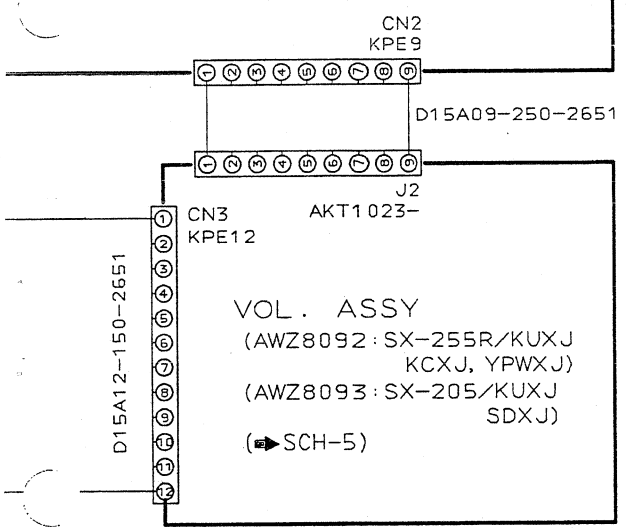
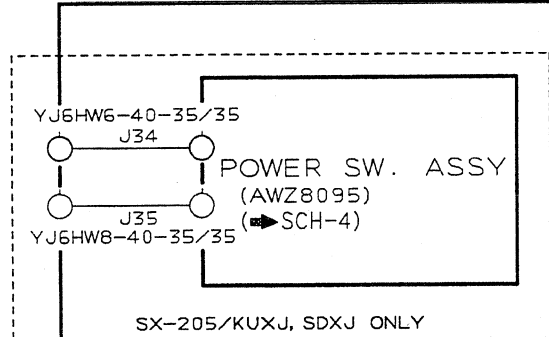

SCH-1

SX-255R, SX-205

5.2 MOTHER ASSY, FM/AM TUNER FE MODULE, SP SW. AND HP. ASSY, TRANS ASSY, REG ASSY AND POWER SW. ASSY (for SX-205)

● FM/AM TUNER FE MODULE

NOTE: VOLTAGE AND CURRENT

\square mV : Signal voltage at FM 1kHz, 100% MOD.

\square or \leftarrow V: DC voltage (V) at no input signal unless otherwise noted.

Value in () is DC voltage at rated power.

\leftarrow mA or \leftarrow mA: DC current at no input signal unless otherwise noted.

\leftarrow mA or \leftarrow mA: DC current at no input signal unless otherwise noted.

SIGNAL ROUTE

\leftarrow (FM) : FM SIGNAL ROUTE

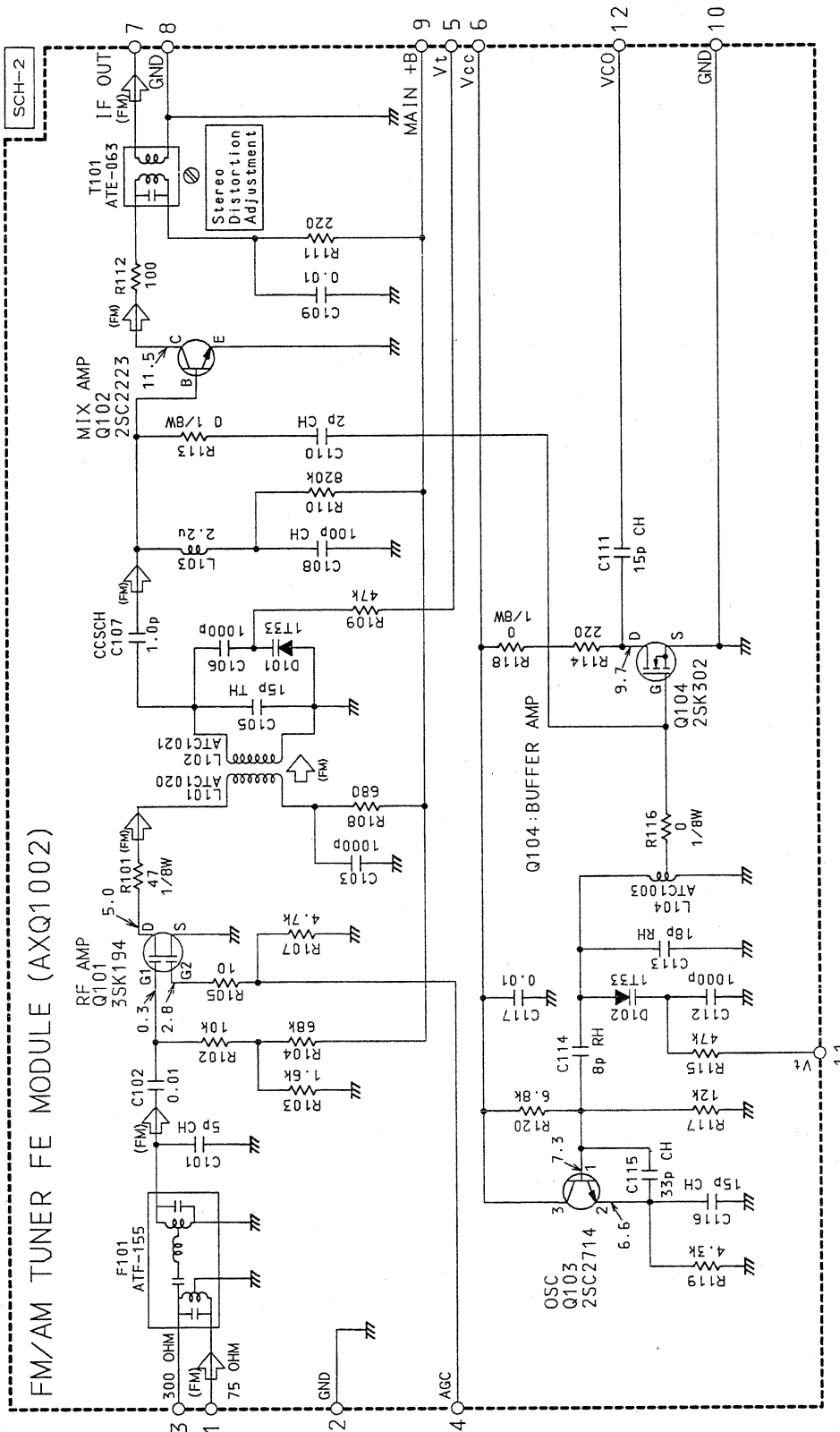

Noted

1. Resistors

Indicated in ohm 1/10W, +5% tolerance unless otherwise noted K:K ohm.

2. Capacitors

Indicated in uF, 50V unless otherwise noted P:PF.

SCH-2

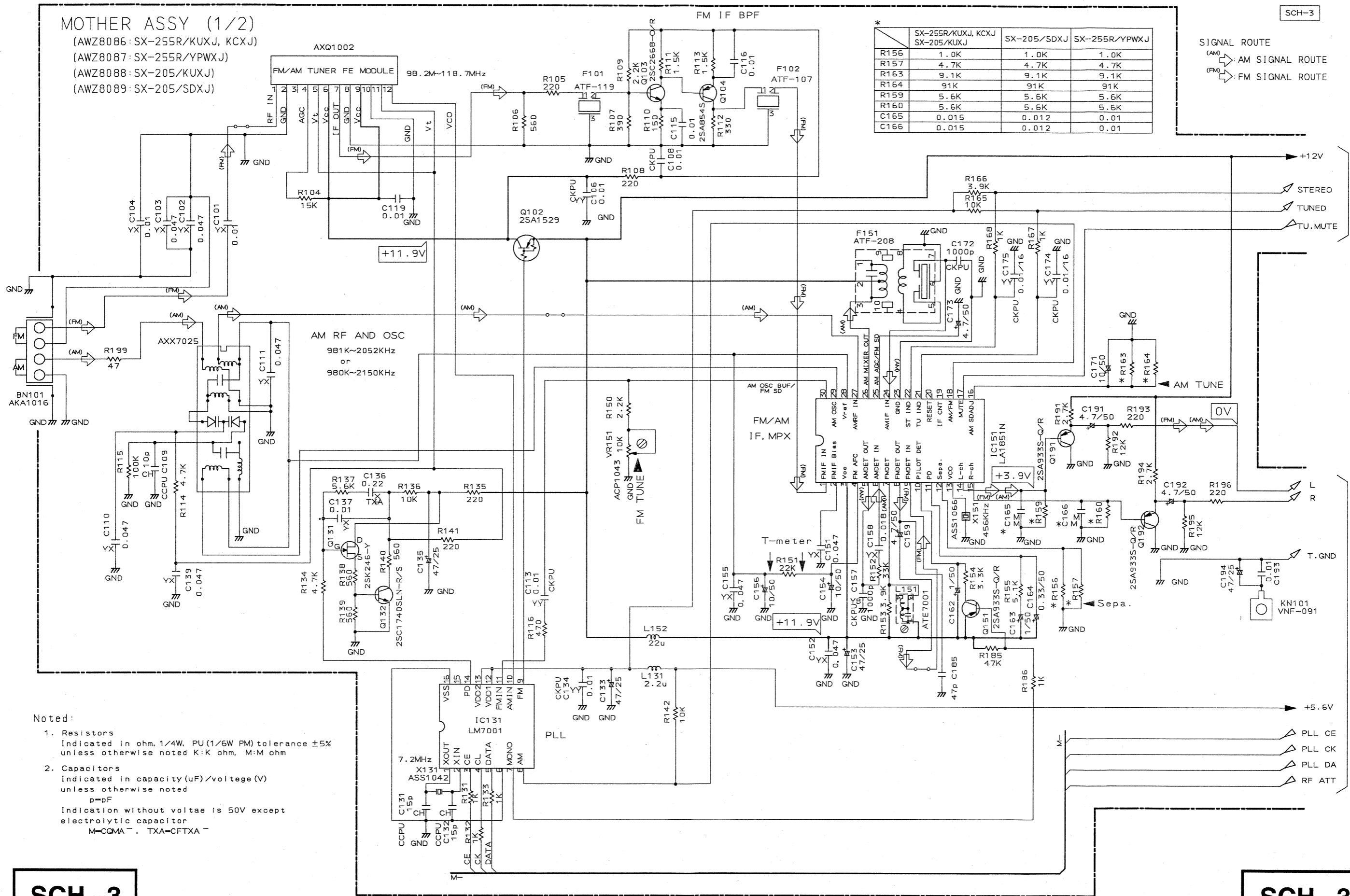

SCH-3

MOTHER ASSY (1/2)

SCH-3

MOTHER ASSY (1/2)

To MOTHER assy (2/2)
 (SCH-4)

To MOTHER assy (2/2)
 (SCH-4)

SX-255R, SX-205

● MOTHER Assy (2/2), SP SW. AND HP. Assy, TRANS Assy, REG Assy and POWER SW. Assy (for SX-205)

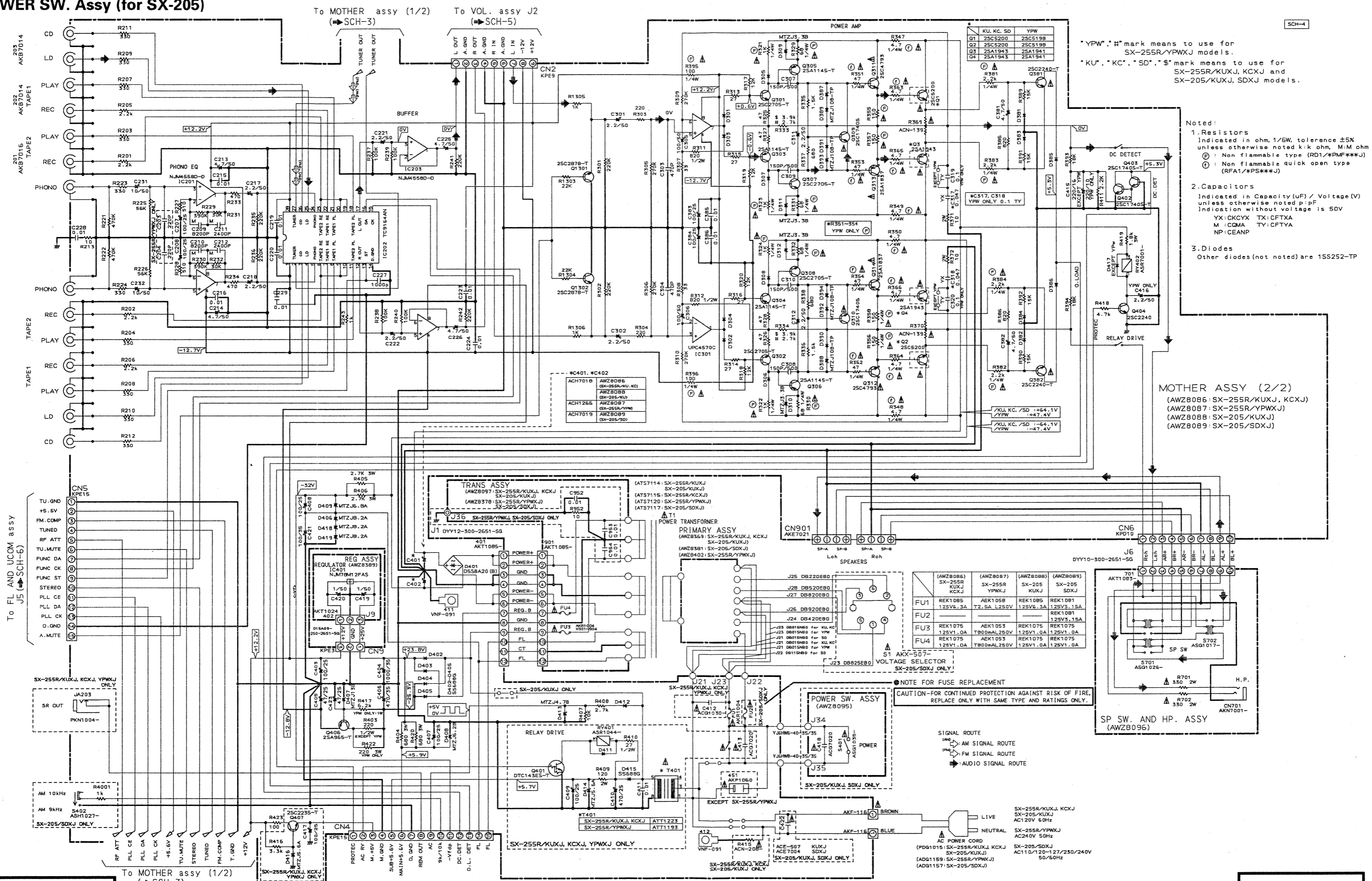

*YPW, # mark means to use for SX-255R/YPWJ models.
 *KU, *KC, *SD, *S mark means to use for SX-255R/KUXJ, KCXJ and SX-205/KUXJ, SDXJ models.

- Noted:
- Resistors
 Indicated in ohm, 1/6W, tolerance $\pm 5\%$ unless otherwise noted k: k ohm, M: M ohm
 (P): Non flammable type (RD1/*PMF***)
 (Q): Non flammable quick open type (RFA1/*PS***)
 - Capacitors
 Indicated in Capacity (μF) / Voltage (V) unless otherwise noted p: pF
 Indication without voltage is 50V
 YX: CKCYX TX: CFTXA
 M: CQMX TV: CFTYA
 NP: CEANP
 - Diodes
 Other diodes (not noted) are 1SS252-TP

MOTHER ASSY (2/2)
 (AWZ8086: SX-255R/KUXJ, KCXJ)
 (AWZ8087: SX-255R/YPWJ)
 (AWZ8088: SX-205/KUXJ)
 (AWZ8089: SX-205/SDXJ)

	(AWZ8086) SX-255R KUXJ, KCXJ	(AWZ8087) SX-255R YPWJ	(AWZ8088) SX-205 KUXJ	(AWZ8089) SX-205 SDXJ
FU1	REK1085 125V5.3A	AEK105B T2.SA L250V	REK1085 125V5.3A	REK1081 125V3.15A
FU2	REK1075 125V1.0A	AEK1053 T800MAL250V	REK1075 125V1.0A	REK1075 125V1.0A
FU3	REK1075 125V1.0A	AEK1053 T800MAL250V	REK1075 125V1.0A	REK1075 125V1.0A
FU4	REK1075 125V1.0A	AEK1053 T800MAL250V	REK1075 125V1.0A	REK1075 125V1.0A

NOTE FOR FUSE REPLACEMENT
 CAUTION-FOR CONTINUED PROTECTION AGAINST RISK OF FIRE,
 REPLACE ONLY WITH SAME TYPE AND RATINGS ONLY.

SIGNAL ROUTE
 AM SIGNAL ROUTE
 FM SIGNAL ROUTE
 AUDIO SIGNAL ROUTE

AC POWER CORD
 (PDG1015: SX-255R/KUXJ, KCXJ
 SX-205/KUXJ)
 (ADG1159: SX-255R/YPWJ)
 (ADG1157: SX-205/SDXJ)

SCH-4

MOTHER ASSY (2/2), REG ASSY,
 SP SW. AND HP. ASSY,
 POWER SW. ASSY (for SX-205)

MOTHER ASSY (2/2), REG ASSY,
 SP SW. AND HP. ASSY,
 POWER SW. ASSY (for SX-205)

SCH-4

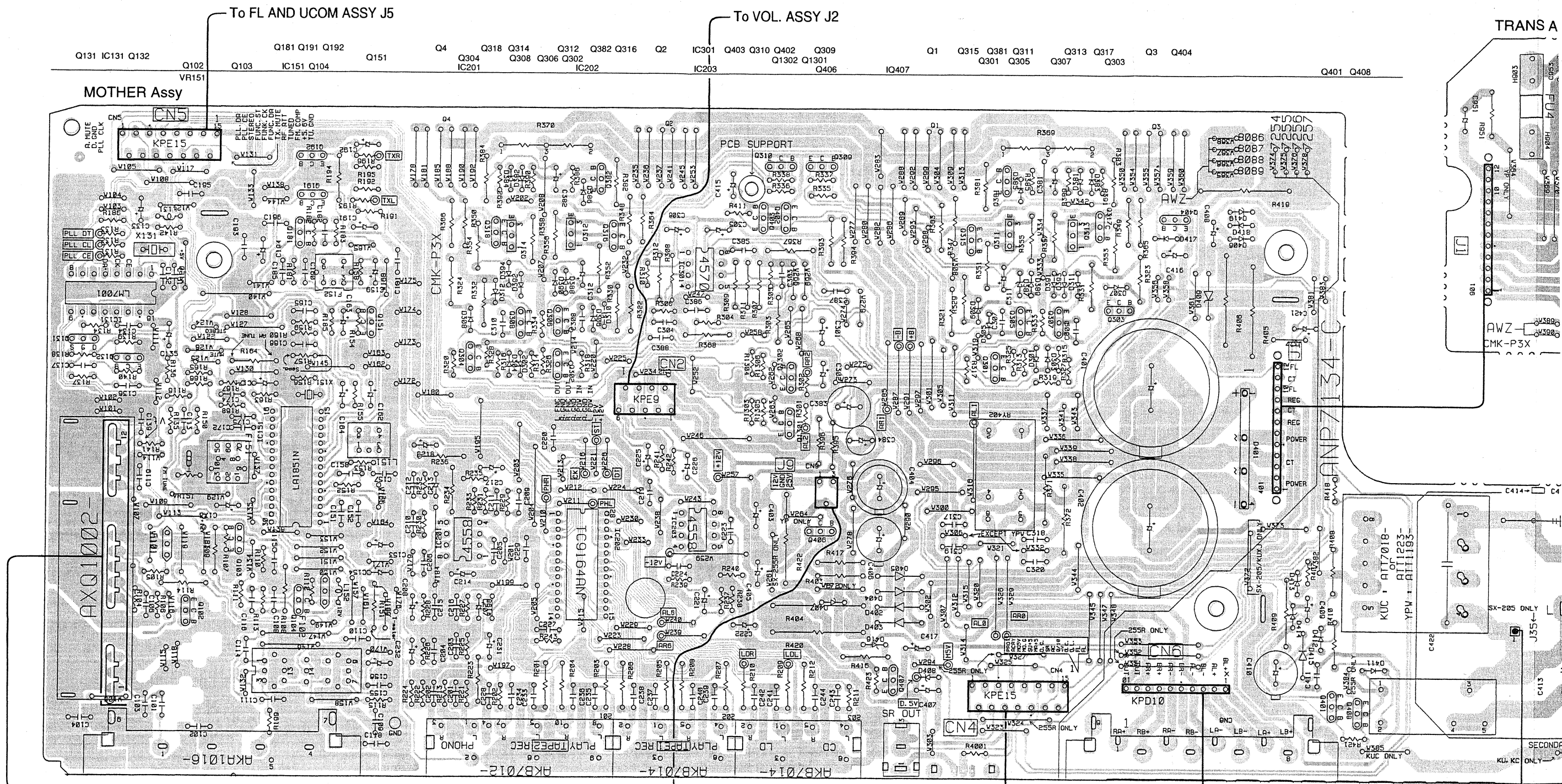

The parts mounted on this PCB include all necessary parts for several destinations. For further information for respective destinations, be sure to check with the schematic diagram.

• This diagram is viewed from the mounted parts side.

FM/AM TUNER FE MODULE

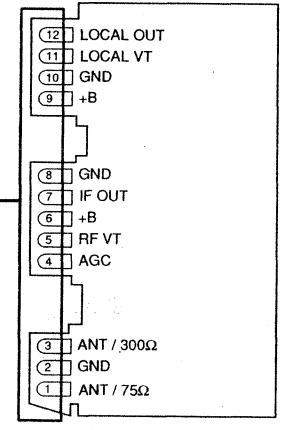

REG Assy

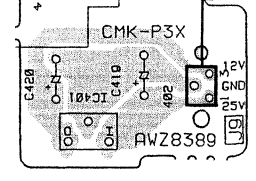

To FL AND UCOM ASSY J4

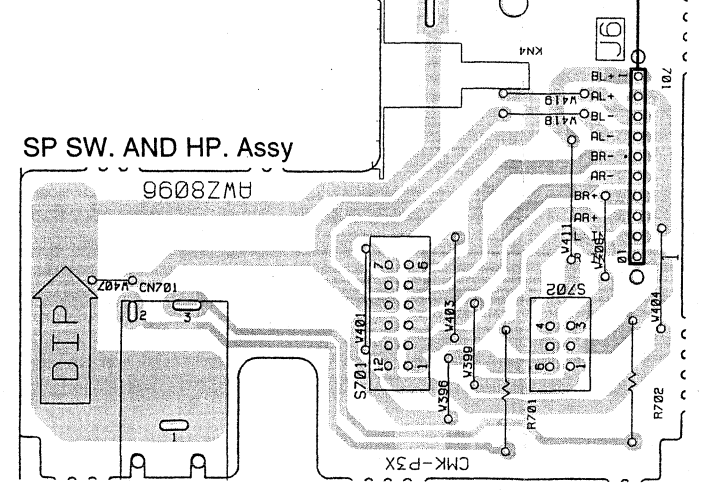

TRANS A

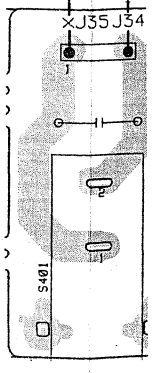
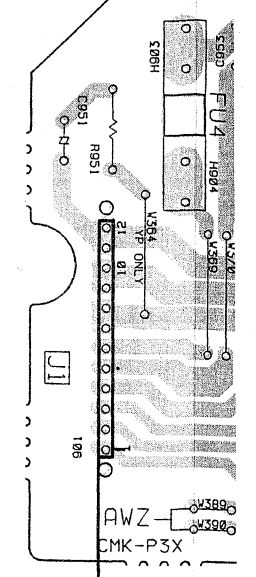

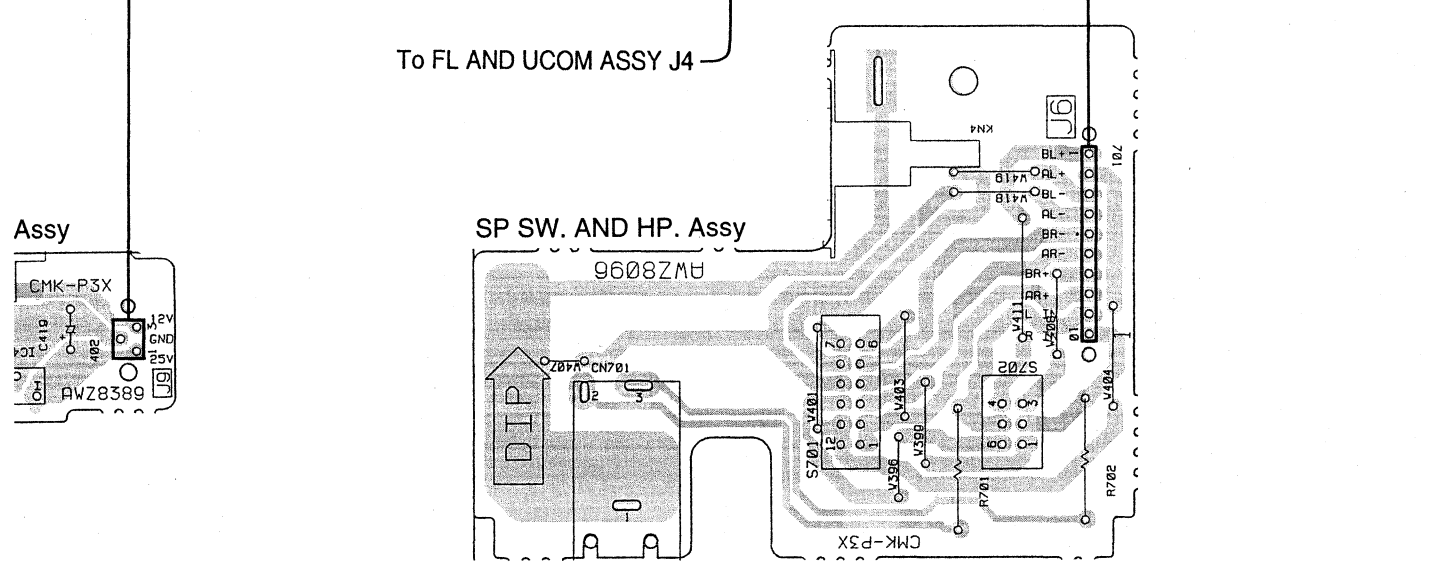
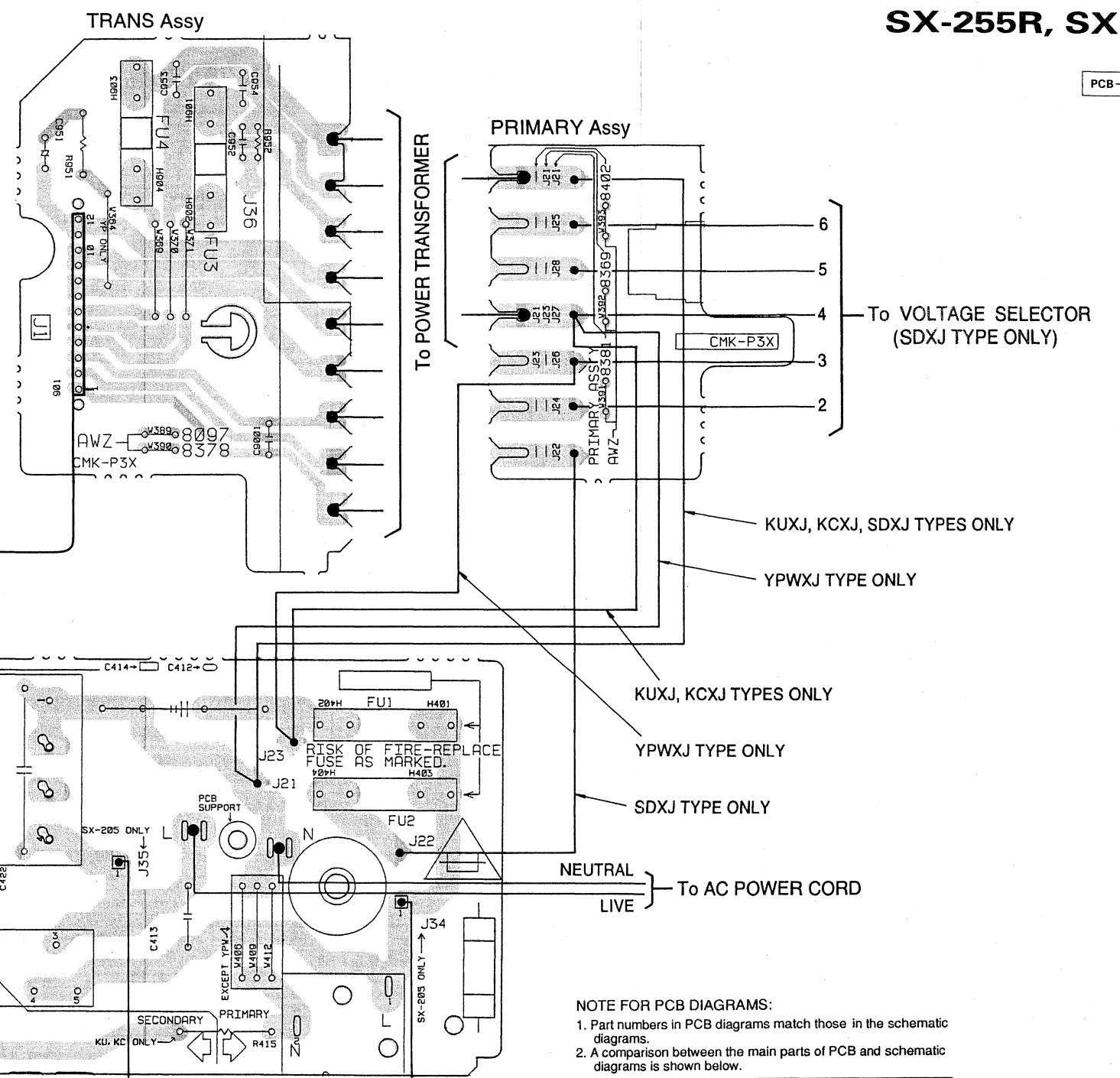
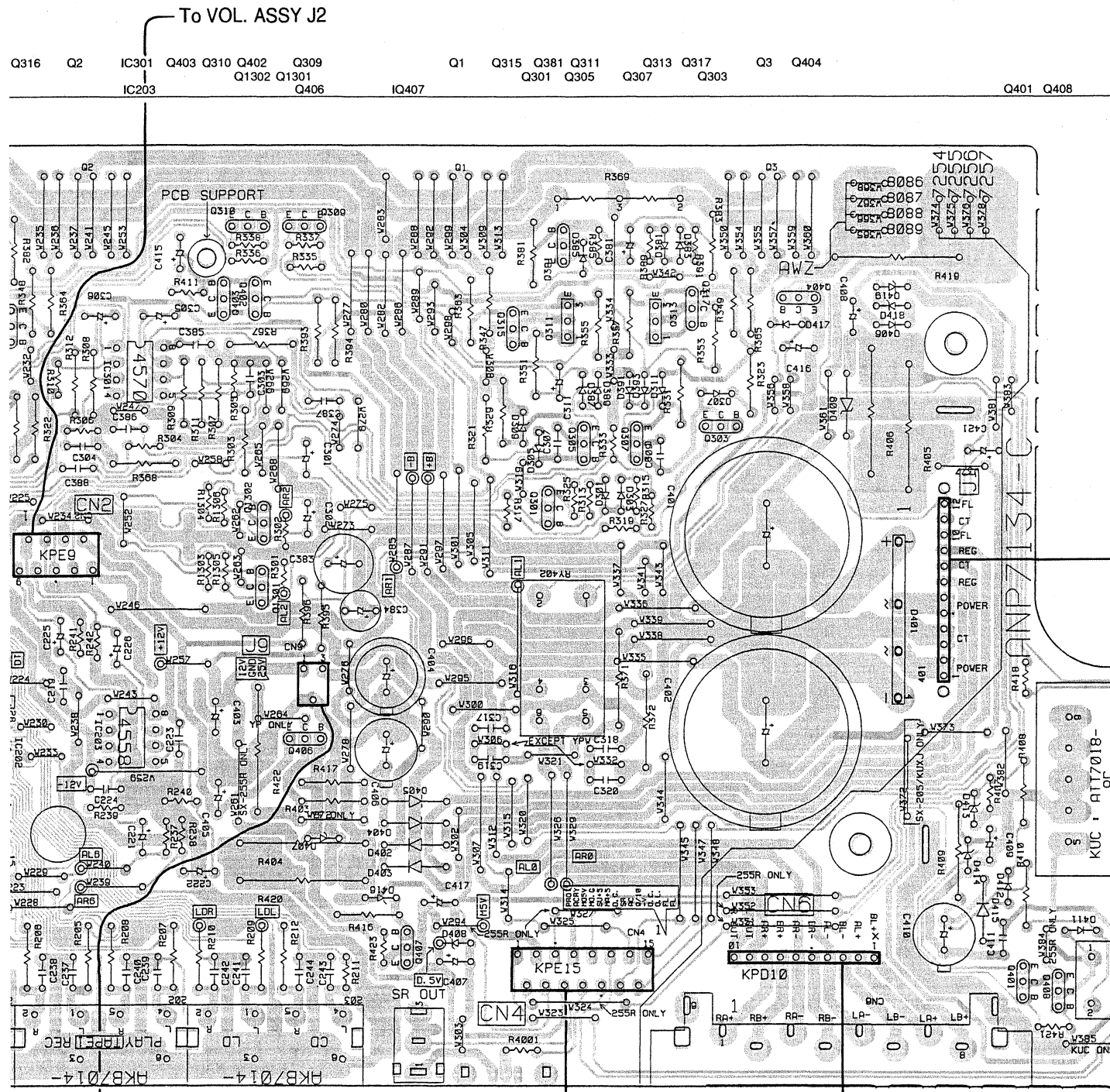

NOTE FOR PCB DIAGRAMS:
 1. Part numbers in PCB diagrams match those in the schematic diagrams.
 2. A comparison between the main parts of PCB and schematic diagrams is shown below.

Symbol in PCB Diagrams	Symbol in Schematic Diagrams	Part Name
		Transistor
		Transistor with resistor
		Field effect transistor
		Resistor array
		3-terminal regulator

SX-255R, SX-205

5.3 VOL. ASSY, FL AND UCOM ASSY AND POWER SW. ASSY (for SX-255R)

● VOL. Assy

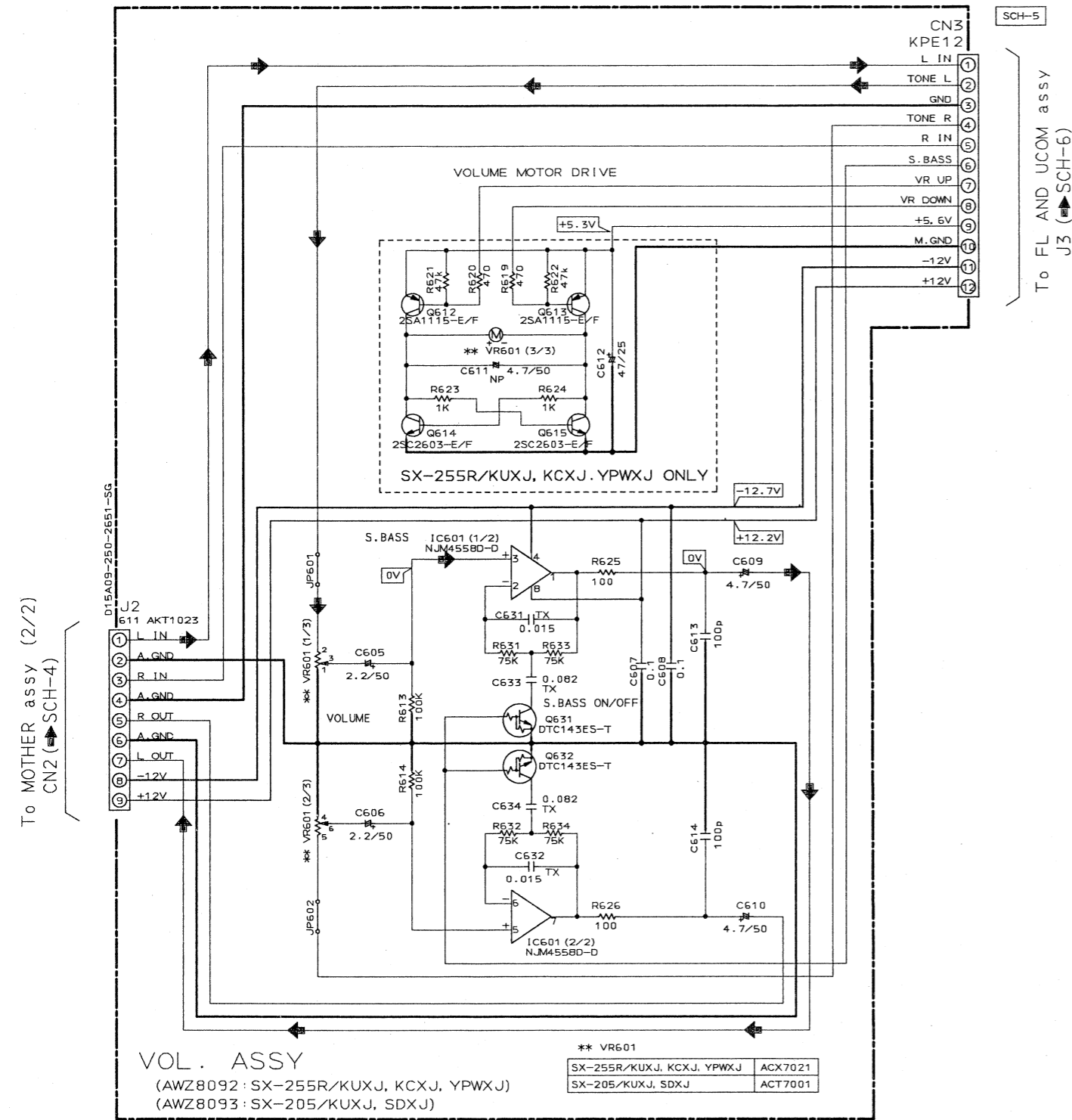

To MOTHER assy (2/2)
CN2 (SCH-4)

SCH-5
To FL AND UCOM assy
J3 (SCH-6)

POWER SW. Assy (for SX-255R)

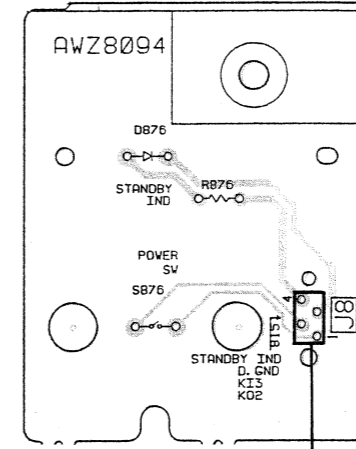

● This diagram is viewed from the mounted parts side.

The parts mounted on this PCB include all necessary parts for several destinations. For further information for respective destinations, be sure to check with the schematic diagram.

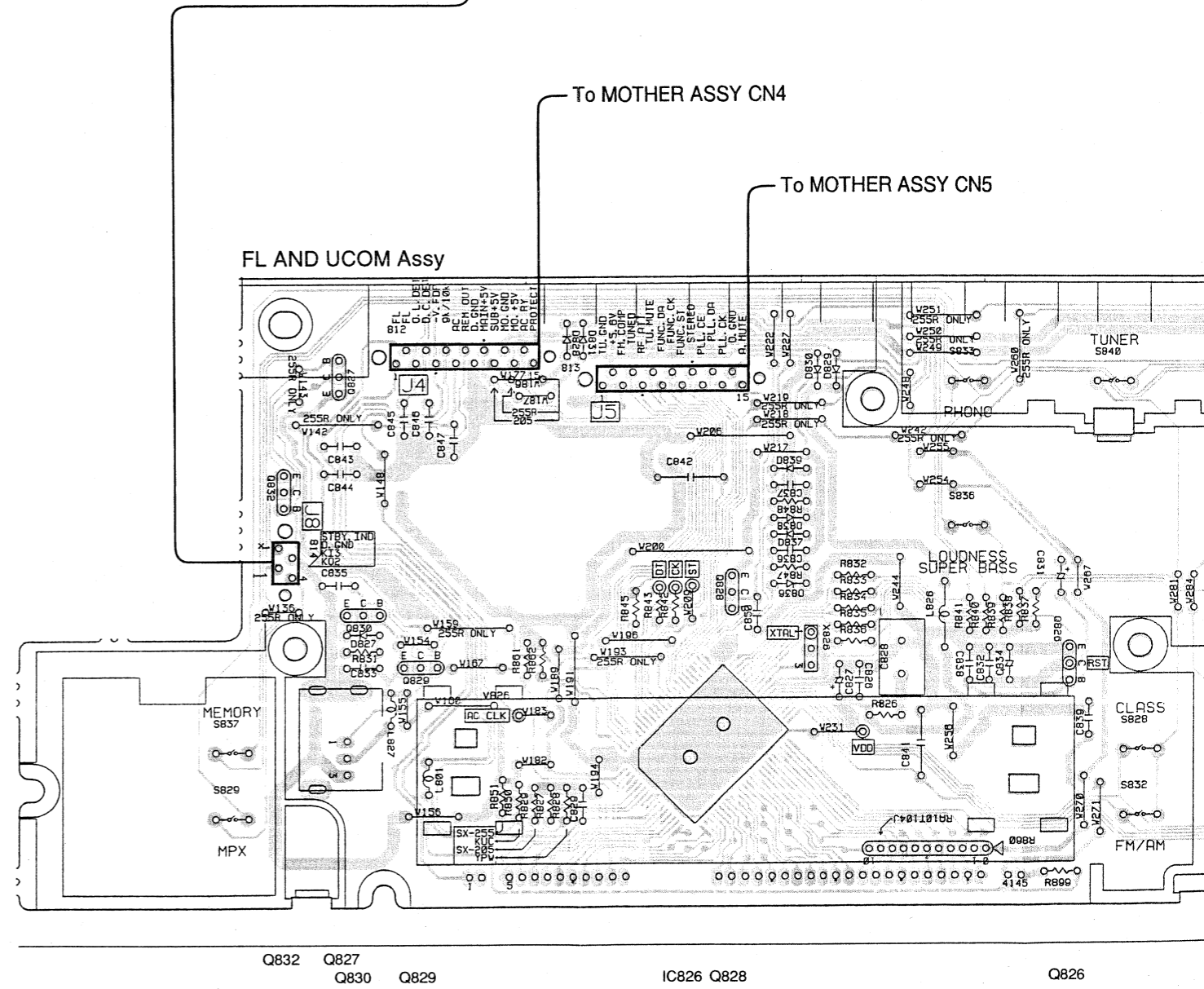

Noted:
 1. Resistors
 Indicated in ohm, 1/5W, tolerance $\pm 5\%$ unless otherwise noted k:k ohm, M:M ohm
 2. Capacitors
 Indicated in Capacity(μ F) / Voltage(V) unless otherwise noted p:pF
 Indication without voltage is 50V
 M:COMA
 NP:CEANP
 TX:CPTXA

SIGNAL ROUTE
 → AUDIO SIGNAL ROUTE

SCH-5

VOL. ASSY

SCH-5

To FL AND UCOM assy
J3 (SCH-6)

POWER SW. Assy (for SX-255R)

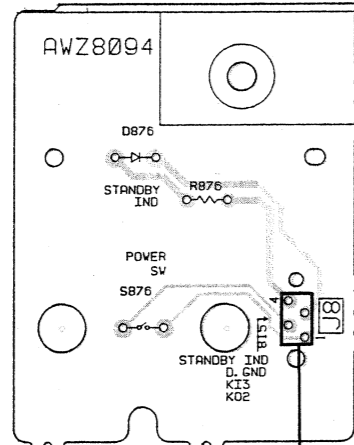

• This diagram is viewed from the mounted parts side.

The parts mounted on this PCB include all necessary parts for several destinations. For further information for respective destinations, be sure to check with the schematic diagram.

FL AND UCOM Assy

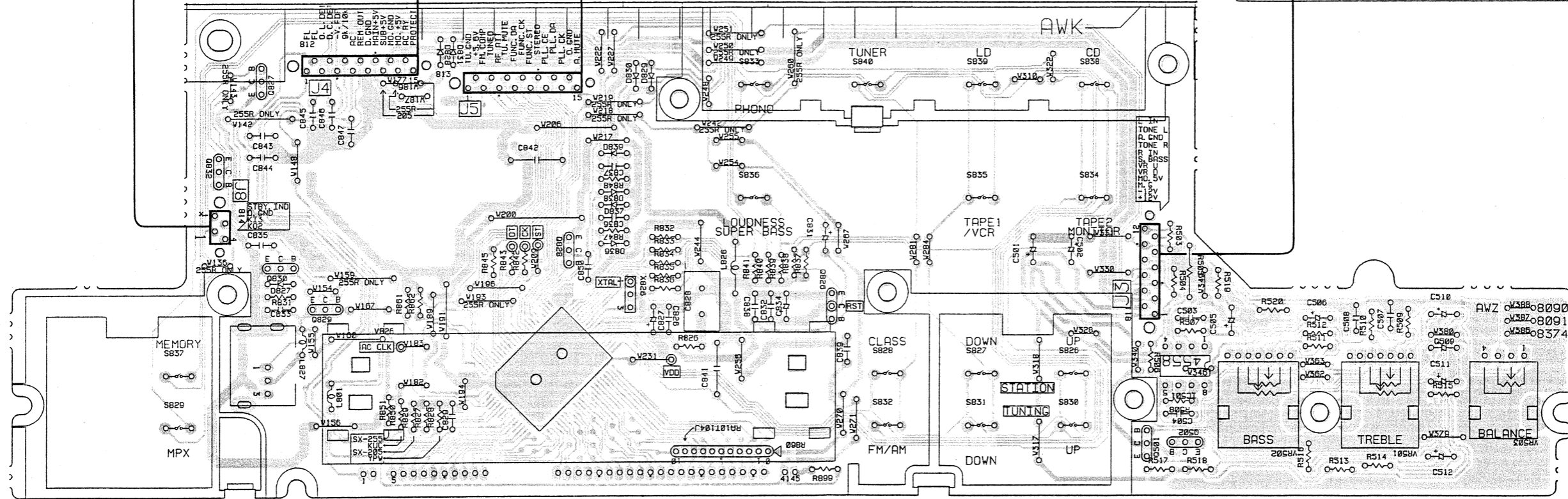

Q832 Q827
Q830 Q829

IC826 Q828

Q826

Q501 IC501 Q502

VR502

VR501

VR503

Q613 Q612 Q614 Q615
Q632 Q631
IC601
VR601

VOL. Assy

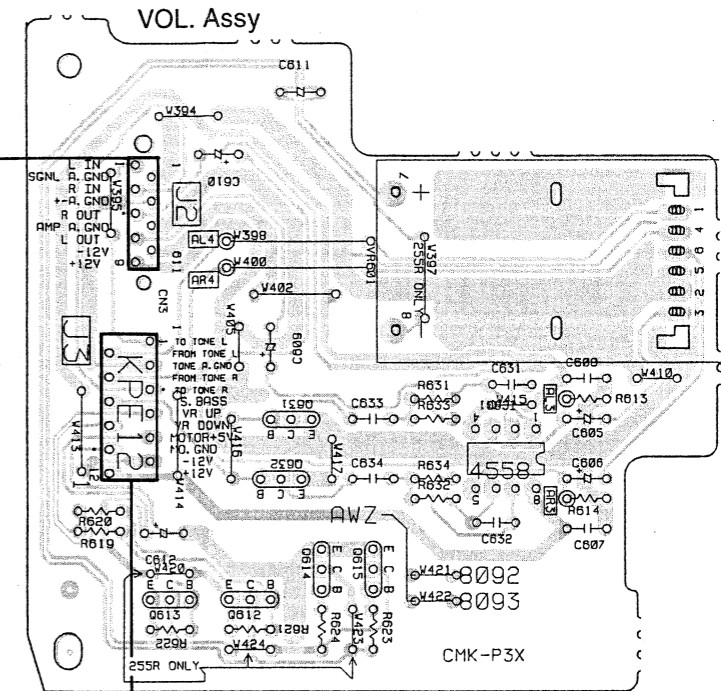

To MOTHER ASSY CN2

To MOTHER ASSY CN4

To MOTHER ASSY CN5

AWZ 08090
08091
08374

Noted:

1. Resistors

Indicated in ohm, 1/6W, tolerance ±5% unless otherwise noted k:k ohm, M:M ohm

2. Capacitors

Indicated in Capacity (uF) / Voltage (V) unless otherwise noted p:pF indication without voltage is 50V
 YY:CKPYY TX:CFYA
 NP:CEAMP TY:CFYA

3. Diodes

Other diodes (not noted) are 1SS252-TP

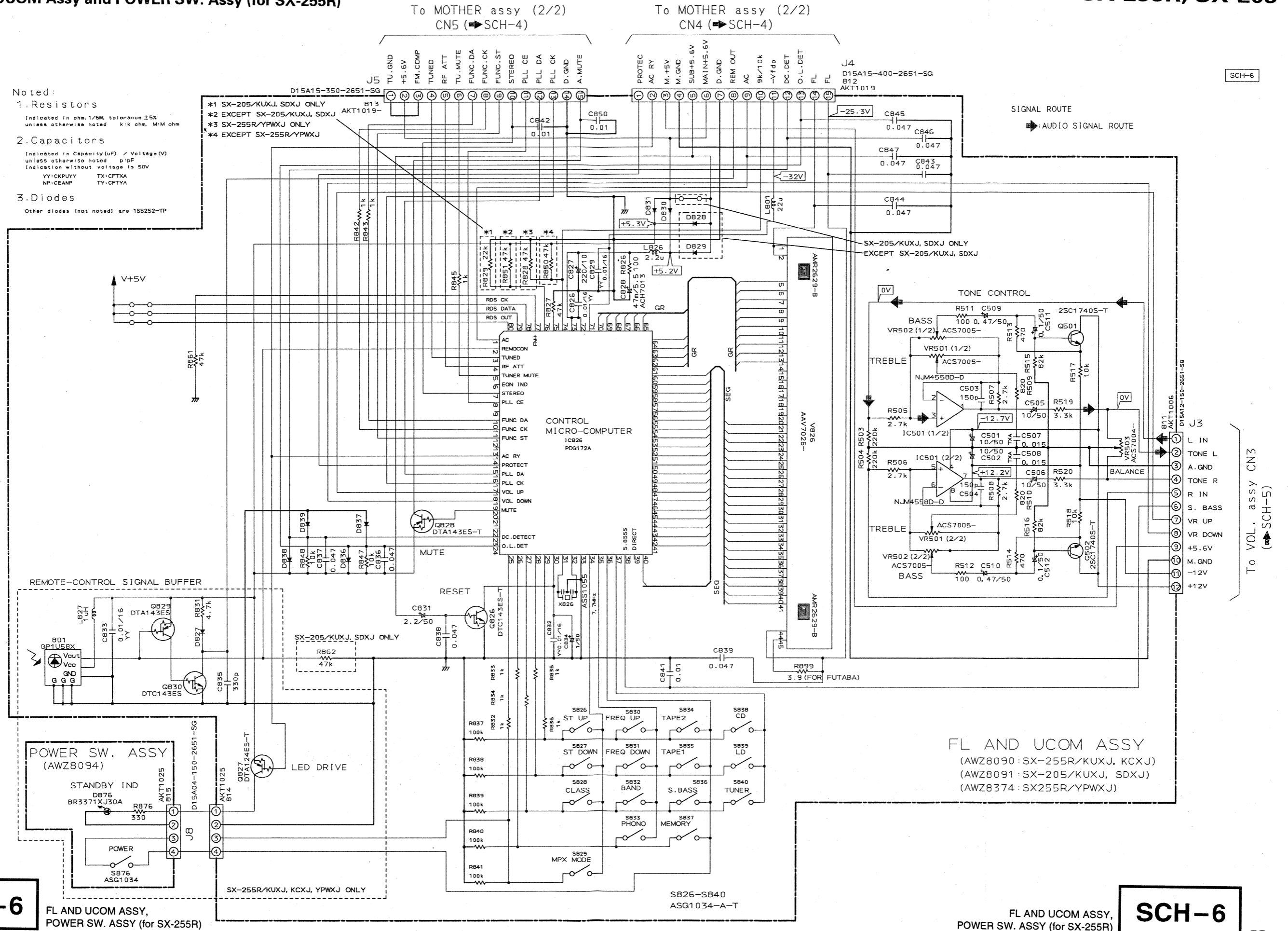

SCH-6

FL AND UCOM ASSY,
POWER SW. ASSY (for SX-255R)

FL AND UCOM ASSY
(AWZ8090: SX-255R/KUXJ, KCXJ)
(AWZ8091: SX-205/KUXJ, SDXJ)
(AWZ8374: SX255R/YPWXJ)

SCH-6

FL AND UCOM ASSY,
POWER SW. ASSY (for SX-255R)

SX-255R, SX-205

Mark No.	Description	Parts No.
COILS AND FILTERS		
L801	AXIAL INDUCTOR	LAU220J
L826	AXIAL INDUCTOR	LAU2R2J
L827	AXIAL INDUCTOR	LAU010J
CAPACITORS		
C501, C502	ELECT. CAPACITOR	CEAS100M50
C503, C504	CERAMIC CAPACITOR	CKPUYB151K50
C505, C506	ELECT. CAPACITOR	CEAS100M50
C507, C508	AUDIO FILM CAPACITOR	CFTXA153J50
C509, C510	ELECT. CAPACITOR	CEASR47M50
C511, C512	ELECT. CAPACITOR	CEAS0R1M50
C826	CERAMIC CAPACITOR	CKPUYY103M16
C827	ELECT. CAPACITOR	CEAS221M10
C828	CAPACITOR (47mF/DC5.5V)	ACH7013
C829	CERAMIC CAPACITOR	CKPUYY103M16
C831	ELECT. CAPACITOR	CEAS2R2M50
C832, C833	CERAMIC CAPACITOR	CKPUYY103M16
C834	ELECT. CAPACITOR	CEAS010M50
C835	CERAMIC CAPACITOR	CKCYB331K50
C836-C838	CERAMIC CAPACITOR	CGCYX473M16
C839	CERAMIC CAPACITOR	CKPUYF473Z50
C841, C842	CERAMIC CAPACITOR	CKPUYY103M16
C843, C844	CERAMIC CAPACITOR	CKCYF103Z50
C845-C847	CERAMIC CAPACITOR	CGCYX473M16
C850	CERAMIC CAPACITOR	CKPUYY103M16
RESISTORS		
VR501, VR502	VARIABLE RESISTOR	ACS7005
VR503	VARIABLE(500k Ω)	ACS7004
	Other Resistors	RD1/4PU□□□J
OTHERS		
	REMOTE RECEIVER UNIT	GP1U58X
V826	FL TUBE	AAV7026
X826	CERAMIC RESONATOR (7.7MHz)	ASS1055
VOL. ASSY		
SEMICONDUCTORS		
IC601	OP-AMP IC	NJM4558D-D
Q612, Q613	TRANSISTOR	2SA1115
Q614, Q615	TRANSISTOR	2SC2603
Q631, Q632	TRANSISTOR	DTC143ES
CAPACITORS		
C605, C606	ELECT. CAPACITOR	CEAS2R2M50
C607, C608	CERAMIC CAPACITOR	CGCYX104M16
C609, C610	ELECT. CAPACITOR	CEAS4R7M50
C611	ELECT. CAPACITOR	CEANP4R7M50
C612	ELECT. CAPACITOR	CEAS470M25
C631, C632	AUDIO FILM CAPACITOR	CFTXA153J50
C633, C634	AUDIO FILM CAPACITOR	CFTXA823J50
RESISTORS		
VR601	VARIABLE RESISTOR (100k-A5 \times 2 Ω)	ACX7021
	Other Resistors	RD1/4PU□□□J
OTHERS		
CN3	CABLE HOLDER CONNECTOR (12P)	AKT1023 KPE12

Mark No.	Description	Parts No.
POWER SW. ASSY		
SEMICONDUCTOR		
D876	RED LED	BR3371XJ30A
SWITCH		
S876	SWITCH	ASG1034
RESISTOR		
R876	CARBON FILM RESISTOR	RD1/4PU331J
SP SW. AND HP. ASSY		
SWITCHES		
S701	PUSH SWITCH	ASG1026
S702	PUSH SWITCH	ASG1017
RESISTORS		
R701, R702	METAL OXIDE RESISTOR	RS2LMF331J
OTHERS		
CN701	JACK	AKN7001
TRANS ASSY		
OTHERS		
	CABLE HOLDER (12P)	AKT1085
REG ASSY		
SEMICONDUCTOR		
IC401	REGULATOR IC	NJM78M12FA
CAPACITORS		
C419, C420	ELECT. CAPACITOR	CEAS010M50

PRIMARY ASSY

PRIMARY Assy has no service part.

BARRIER ASSY

BARRIER Assy has no service part.

SX-255R, SX-205

7. ADJUSTMENTS

ADJUSTMENT OF FM TUNER SECTION

- Set the FM/AM selector to FM BAND.
- Connect the wiring as shown in Fig. 1-1.

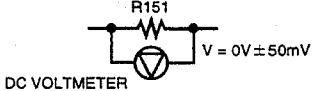
Step No.	Adjustment Title	FM SG (1kHz, ± 75 kHz dev.)		Reception Frequency Display	Adjustment Location	Specifications
		Frequency (MHz)	Level (dB μ V)			
1	Center Adjustment	98	60	98.0 MHz	L151	Adjust so that the DC voltage of R151's both ends becomes $0V \pm 50mV$. 
2	Front End Sencitivity Check	98	Less than 10	98.0 MHz	—	Less than 10 dB μ V
3	Stereo Distortion Check	89	60	89.0 MHz	T101	Less than 2%. Check that it becomes within the standard by turning the IFT T101 in the FM/AM TUNER MODULE less than $\pm 90^\circ$ in case out of standard.
4	Stereo Separation Check	89	60	89.0 MHz	—	Less than 23 dB. In case out of standard, cut the R157.
5	TUNED IND. Lighting Level	98	18 (± 3 dB)	98.0 MHz	VR151	18 dB μ V ± 3 dB. Adjust so that the indicator of TUNED IND. starts to light up.

Note: Make indicator adjustments in order of AM \rightarrow FM.

ADJUSTMENT OF AM (MW) TUNER SECTION

- Set the FM/AM selector to AM (MW) BAND.
- Connect the wiring as shown in Fig. 1-1.

Step No.	Adjustment Title	AM SG (400Hz, 30% Mod.)		Reception Frequency Display	Adjustment Location	Specifications
		Frequency (kHz)	Level (dB μ V/m)			
1	TUNED IND. Lighting Level Check	999 ^{*1}	Less than 65	999kHz ^{*1}	—	Less than 65dB μ V/m. In case out of standard, cut the R164.

*1 : For the area using 10 kHz step, frequencies should be 1000 kHz.

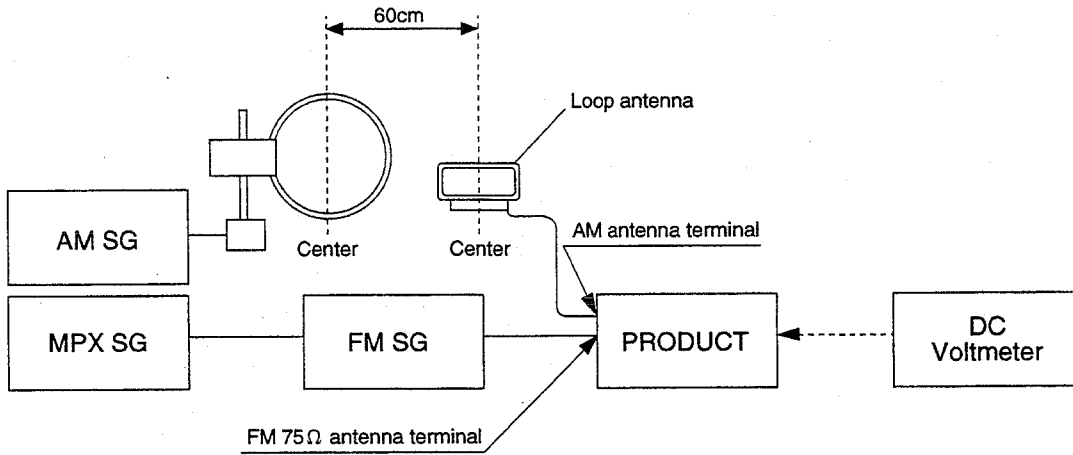
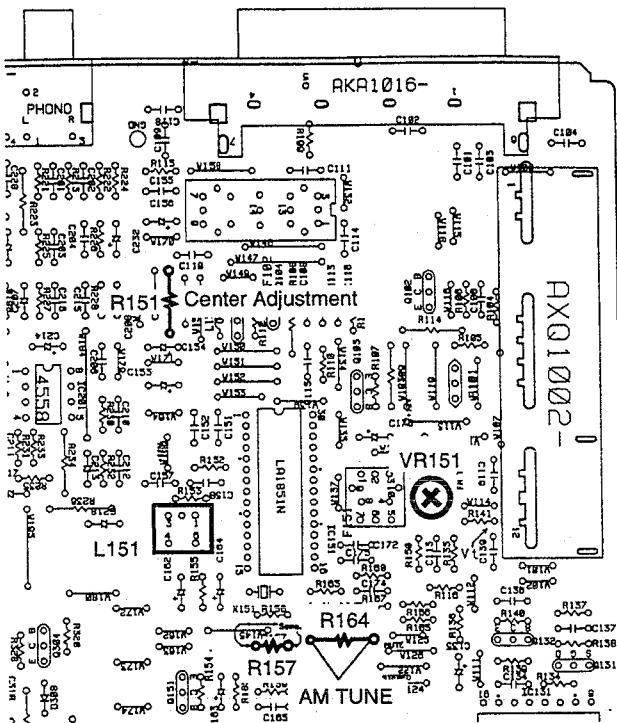

Fig. 1-1 FM and AM Adjustment Wiring Diagram

MOTHER Assy



FM/AM TUNER FE MODULE

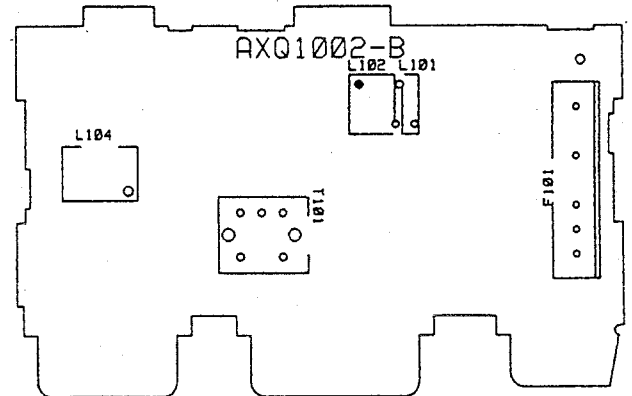

Fig. 1-2 Adjustment Points

SX-255R, SX-205

8. IC INFORMATION

- The information shown in the list is basic information and may not correspond exactly to that shown in the schematic diagrams.

■ PDG172A (IC826: FL AND UCOM ASSY)

● Receiver Control Micro-computer

● Block Diagram

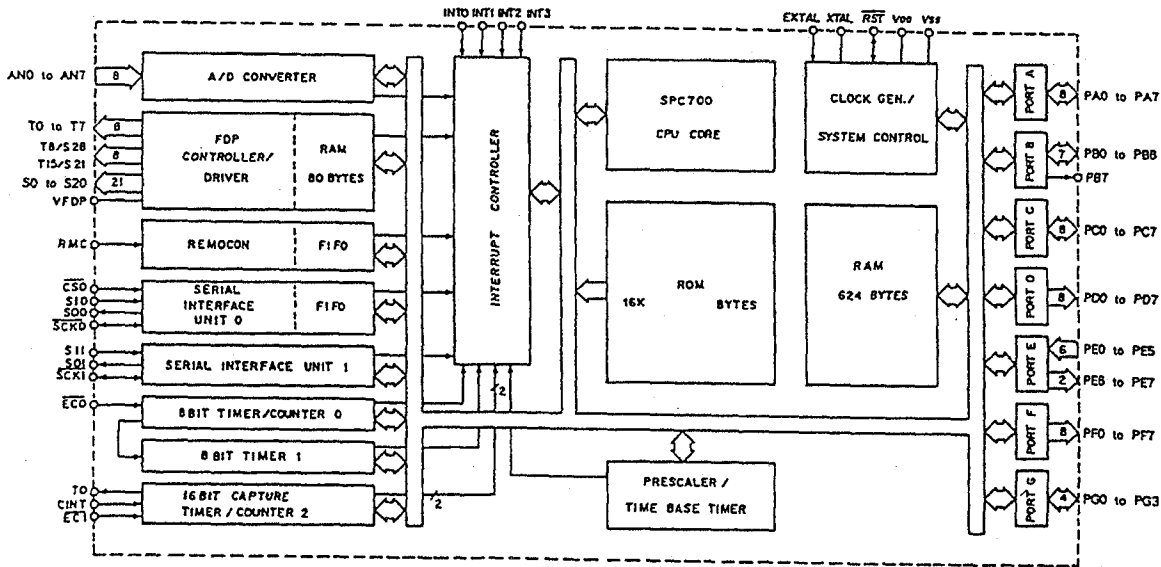

● Pin Assignment (Top view)

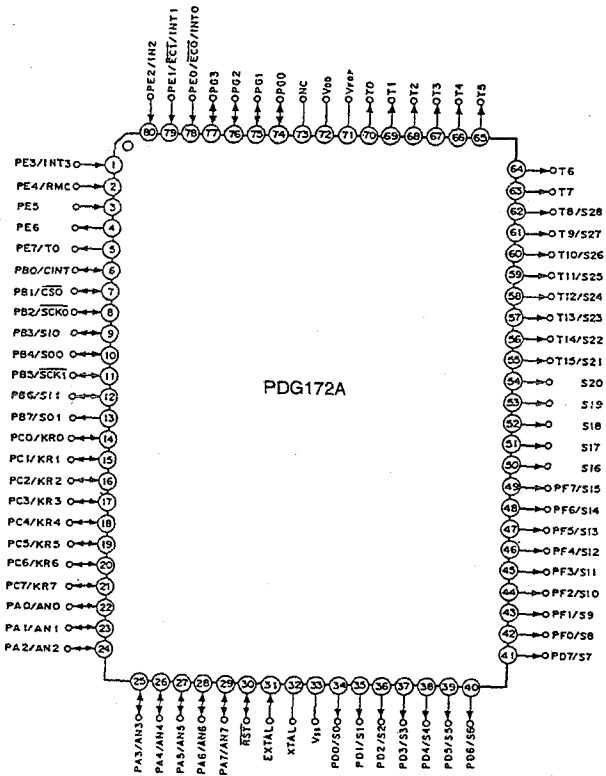

● Pin Function

No.	Pin Name	I/O	Description
1	PE3/INT3	I	External interrupt request input terminal
2	PE4/RMC	I	Remote control reception circuit input terminal
3	PE5	I	
4	PE6	O	
5	PE7/T0	O	16 bit timer/counter rectangular wave output terminal
6	PB0/CINT	I/O	External capture input terminal to the 16-bit timer/counter
7	PB1/CS0	I/O	Serial interface (CH 0) chip select input terminal
8	PB2/SCK0	I/O	Serial clock (CH 0) I/O terminal
9	PB3/SI0	I	Serial data (CH 0) input terminal
10	PB4/SO0	O	Serial data (CH 0) output terminal
11	PB5/SCK1	I/O	Serial clock (CH 1) I/O terminal
12	PB6/SI1	I	Serial data (CH 1) input terminal
13	PB7/SO1	O	Serial data (CH 1) output terminal

SX-255R, SX-205

No.	Pin Name	I/O	Description
14 21	PC0/KR0 PC7/KR7	I	Key return input terminal for key scan by FDP segment signal
22 29	PA0/AN0 PA7/AN7	I	A/D converter analog input terminal
30	RST	I/O	"L" level active system reset terminal. The RST terminals are I/O terminals, and at the time of power supply start-up, the built-in power ON reset function operates and executes "L" level output. (Mask option)
31	EXTAL	I	System clock oscillation crystal connection terminal. For external clock supply, execute input to the EXTAL terminal and supply input of a reverse-phase clock signal to the XTAL terminal.
32	XTAL	O	
33	V _{ss}	—	GND terminal
34 41	PD0/S0 PD7/S7	O	FDP segment signal output terminal
42 49	PF0/S8 PF7/S15		
50 54	S16 S20		
55 62	T15/S21 T8/S28	O	Combined output terminal for FDP timing signal and segment signal
63 70	T7 T0	O	FDP timing signal output terminal
71	VFDP	—	FDP voltage supply signal when internal resistance has been specified by the mask option.
72	VDD	—	Positive power supply terminal
73	NC	—	NC terminal Connect this terminal to VDD for normal operation.
74 77	PG0 PG3	I/O	

No.	Pin Name	I/O	Description
78	PE0/INT0/ $\overline{EC0}$	I	External interrupt request input terminal Timer/counter external event input terminal
79	PE1/INT1/ $\overline{EC1}$		
80	PE2/INT2	I	External interrupt request input terminal

SX-255R, SX-205

9. FL INFORMATION

■ AAV7026 (V826: FL AND UCOM ASSY)

● FL Tube

● Grid Assignment

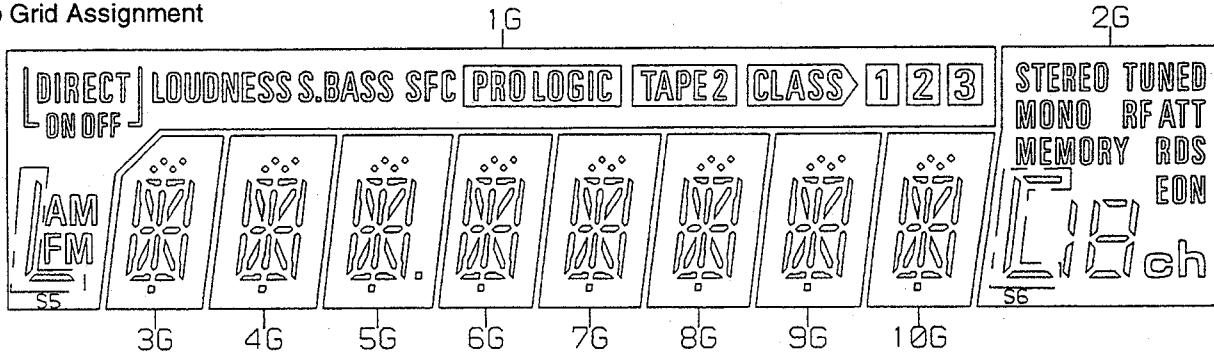

● Anode Connection

	1G	2G	3G, 4G, 6G~10G	5G
S1	SS	SS	a1	a1
S2	FM	2b, 2c	a2	a2
S3	AM	1a	h	h
S4	DIRECT	1b	j	j
S5	ON	1c	k	k
S6	OFF	1d	b	b
S7	PROLOGIC	1e	f	f
S8	SFC	1f	m	m
S9	LOUDNESS	1g	g	g
S10	S.BASS	ch	c	c
S11	TAPE 2	STEREO	e	e
S12	CLASS	TUNED	r	r
S13	1	MONO	p	p
S14	2	RFATT	n	n
S15	3	MEMORY	d1	d1
S16	-	RDS	d2	d2
S17	-	EON	DP	DP
S18	-	-	S1, S3	S1, S3
S19	-	-	S4	S4
S20	-	-	S2	S2
S21	-	-	-	DP1

● Pin Assignment

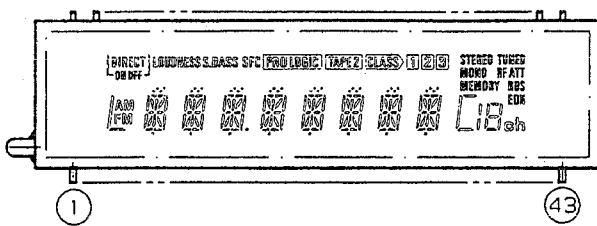

● Pin Connection

PIN NO.	1	2	3	4	5	6	7	8	9	10	11	12	13	14	15	16	17	18	19	20	21	22	23	24	25	26	27	28	29	30	31	32	33	34	35	36	37	38	39	40	41	42	43			
CONNECTION	F	F	N	1	2	3	4	5	6	7	8	9	0	N	N	N	N	N	N	2	1	1	1	1	1	1	1	1	P	P	P	P	P	P	P	P	P	P	P	P	1	1	2	N	N	F
	1	1	P	G	G	G	G	G	G	G	G	G	X	X	X	X	X	1	6	7	5	3	2	4	1	0	9	8	7	6	5	3	4	2	1	8	9	0	P	X	2					

NOTE 1) F1, F2 --- Filament
 2) NP ----- No pin
 3) NX ----- No extend pin
 4) DL ----- Datum Line
 5) 1G~10G --- Grid

10. FOR SX-255R/KCXJ, YPWXJ, SX-205/KUXJ AND SDXJ

NOTES :

- Parts marked by "NSP" are generally unavailable because they are not in our Master Spare Parts List.
- The Δ mark found on some component parts indicates the importance of the safety factor of the part. Therefore, when replacing, be sure to use parts of identical designation.
- Parts marked by "⊙" are not always kept in stock. Their delivery time may be longer than usual or they may be unavailable.
- When ordering resistors, first convert resistance values into code form as shown in the following examples.

Ex. 1 When there are 2 effective digits (any digit apart from 0), such as 560 ohm and 47k ohm (tolerance is shown by J = 5%, and K = 10%).

560 Ω \rightarrow 56 \times 10¹ = 561 RD1/4PU **5 6 1** J
 47k Ω \rightarrow 47 \times 10³ = 473 RD1/4PU **4 7 3** J
 0.5 Ω \rightarrow 0R5 RN2H **0 R 5** K
 1 Ω \rightarrow 1R0 RSIP **1 R 0** K

Ex. 2 When there are 3 effective digits (such as in high precision metal film resistors).

5.62k Ω \rightarrow 562 \times 10¹ = 5621 RN1/4PC **5 6 2 1** F

CONTRAST OF MISCELLANEOUS PARTS

SX-255R/KCXJ, YPWXJ, SX-205/KUXJ, SDXJ and SX-255R/KUXJ have the same construction except for the following:

Mark	No.	Symbol & Description	Part No.					Remarks
			SX-255R/ KUXJ	SX-255R/ KCXJ	SX-255R/ YPWXJ	SX-205/ KUXJ	SX-205/ SDXJ	
NSP		COMPLEX Assy	AWK7254	AWK7254	AWK7255	AWK7256	AWK7257	
	38	MOTHER Assy	AWZ8086	AWZ8086	AWZ8087	AWZ8088	AWZ8089	
	39	FL AND UCOSM Assy	AWZ8090	AWZ8090	AWZ8374	AWZ8091	AWZ8091	
	43	VOL. Assy	AWZ8092	AWZ8092	AWZ8092	AWZ8093	AWZ8093	
	44	POWER SW. Assy	AWZ8094	AWZ8094	AWZ8094	AWZ8095	AWZ8095	
	41	TRANS Assy	AWZ8097	AWZ8097	AWZ8378	AWZ8097	AWZ8378	
NSP	46	PRIMARY Assy	AWZ8369	AWZ8369	AWZ8402	AWZ8369	AWZ8381	*1
NSP	47	BARRIER Assy	AWZ8371	AWZ8371	Not Used	AWZ8371	Not Used	
Δ	5, 6	Q3, Q4 Transistor	2SA1943	2SA1943	2SA1941	2SA1943	2SA1943	
Δ	3, 4	Q1, Q2 Transistor	2SC5200	2SC5200	2SC5198	2SC5200	2SC5200	
Δ	7	T1 Power Transformer (AC120V)	ATS7114	ATS7115	Not Used	ATS7114	Not Used	
Δ	7	T1 Power Transformer (AC240V)	Not Used	Not Used	ATS7120	Not Used	Not Used	
Δ	7	T1 Power Transformer (AC110V/120-127V/230V/240V)	Not Used	Not Used	Not Used	Not Used	ATS7117	
Δ	11, 12	FU3, FU4 Fuse (1A)	REK1075	REK1075	Not Used	REK1075	REK1075	
Δ	11, 12	FU3, FU4 Fuse (T800mA)	Not Used	Not Used	AEK1053	Not Used	Not Used	
Δ	9	FU1 Fuse (6.3A)	REK1085	REK1085	Not Used	REK1085	Not Used	
Δ	9	FU1 Fuse (T2.5A)	Not Used	Not Used	AEK1058	Not Used	Not Used	
Δ	9, 10	FU1, FU2 Fuse (3.15A)	Not Used	Not Used	Not Used	Not Used	REK1081	
Δ	23	Voltage Selector	Not Used	Not Used	Not Used	Not Used	AKX-507	
Δ	8	AC Power Cord	PDG1015	PDG1015	ADG1159	PDG1015	ADG1157	
	2	Front Panel	AMB7331	AMB7331	AMB7339	AMB7333	AMB7333	
	14	Rear Panel	ANC7339	ANC7386	ANC7342	ANC7340	ANC7344	
	16	Foot	AEC1505	AEC1505	Not Used	AEC1505	AEC1505	
	26	Insulator Assy	Not Used	Not Used	DXA1490	Not Used	Not Used	
	56	Insulator	Not Used	Not Used	PNW1912	Not Used	Not Used	
	20	Strain Relief	CM-22C	CM-22C	CM-22B	CM-22C	CM-22B	
	25	LED Lens	AAK2553	AAK2553	AAK2553	Not Used	Not Used	
	1	FL Panel	AAK7239	AAK7239	AAK7239	AAK7241	AAK7241	
	55	Nut	Not Used	Not Used	Not Used	NK90FUC	NK90FUC	
	35	Spring	Not Used	Not Used	Not Used	ABH7111	ABH7111	

SX-255R, SX-205

Mark	No.	Symbol & Description	Part No.					Remarks
			SX-255R/ KUXJ	SX-255R/ KCXJ	SX-255R/ YPWXJ	SX-205/ KUXJ	SX-205/ SDXJ	
NSP	68	Packing Case	AHD7265	AHD7265	AHD7269	AHD7267	AHD7271	
	57	Remote Control Unit (CU-SX108)	AXD7085	AXD7085	AXD7085	Not Used	Not Used	
	61	Battery Cover	AZA7123	AZA7123	AZA7123	Not Used	Not Used	
	58	Battery (R6P, AA)	VEM-013	VEM-013	VEM-013	Not Used	Not Used	
	63	Operating Instructions (English)	ARB7064	ARB7064	ARB7067	ARB7064	ARB7064	
NSP		Operating Instructions (French)	Not Used	ARC7102	Not Used	Not Used	Not Used	
		Operating Instructions (Spanish/Chinese)	Not Used	Not Used	Not Used	Not Used	ARC7103	
	64	Warranty Card	ARY1051	ARY1075	PRY1003	ARY1051	Not Used	
	62	Caution 220V Label	Not Used	Not Used	Not Used	Not Used	ARR1003	

Notes *1: AWZ8369 and AWZ8402 has no service part. For AWZ8381, refer to " ■ PCB PARTS LIST".

No.: The numbers are location number(s) on the " 3. EXPLODED VIEWS, PACKING AND PARTS LIST", respectively.

FL AND UCOM Assy

AWZ8374, AWZ8091 and AWZ8090 have the same construction except for the following:

Mark	Symbol & Description	Part No.			Remarks
		AWZ8090	AWZ8374	AWZ8091	
	Q827	DTA124ES	DTA124ES	Not Used	
	Q829	DTA143ES	DTA143ES	Not Used	
	Q830	DTC143ES	DTC143ES	Not Used	
	D827-D829	1SS252	1SS252	Not Used	
	L827	LAU010J	LAU010J	Not Used	
	C833	CKPUYY103M16	CKPUYY103M16	Not Used	
	C835	CKCYB331K50	CKCYB331K50	Not Used	
	R828	Not Used	RD1/4PU473J	Not Used	
	R829	Not Used	Not Used	RD1/4PU223J	
	R831	RD1/4PU472J	RD1/4PU472J	Not Used	
	R850	RD1/4PU473J	Not Used	RD1/4PU473J	*2
	R851	RD1/4PU473J	RD1/4PU473J	Not Used	
	R862	Not Used	Not Used	RD1/4PU473J	
	Remote Receiver Unit	GPIU58X	GPIU58X	Not Used	

Note *2: Refer to " 5. SCHEMATIC AND PCB CONNECTION DIAGRAMS".

VOL. Assy

AWZ8093 and AWZ8092 have the same construction except for the following:

Mark	Symbol & Description	Part No.		Remarks
		AWZ8092	AWZ8093	
	Q612, Q613	2SA1115	Not Used	
	Q614, Q615	2SC2603	Not Used	
	C611	CEANP4R7M50	Not Used	
	C612	CEAS470M25	Not Used	
	VR601	ACX7021	ACT7001	
	R619, R620	RD1/4PU471J	Not Used	
	R621, R622	RD1/4PU473J	Not Used	
	R623, R624	RD1/4PU102J	Not Used	

MOTHER Assy

AWZ8087, AWZ8088, AWZ8089 and AWZ8086 have the same construction except for the following:

Mark	Symbol & Description	Part No.				Remarks
		AWZ8086	AWZ8087	AWZ8088	AWZ8089	
△	Q401	DTC143ES	DTC143ES	Not Used	Not Used	
	Q407	2SC2235	2SC2235	Not Used	Not Used	
	D411	1SS252	1SS252	Not Used	Not Used	
	D414, D416	MTZJ5.6A	MTZJ5.6A	Not Used	Not Used	
	D415	S5688G	M5688G	Not Used	Not Used	
	D417	1SS252	Not Used	1SS252	1SS252	
	S402 (9kHz/10kHz)	Not Used	Not Used	Not Used	ASH1027	*2
	RY401	ASR1044	ASR1044	Not Used	Not Used	
	T401	ATT1223	ATT1193	Not Used	Not Used	
	C165, C166	CFTXA153J50	CFTXA103J50	CFTXA153J50	CFTXA123J50	
	C203, C204	Not Used	CCCSL221J50	Not Used	Not Used	*2
	C317, C318	CFTXA473J50	CFTYA104J50	CFTXA473J50	CFTXA473J50	
	C319, C320	Not Used	CFTYA104J50	Not Used	Not Used	*2
	C401, C402	ACH7018 (8200 μ F/DC71V)	ACH1265 (8200 μ F/DC50V)	ACH7018 (8200 μ F/DC71V)	ACH7018 (8200 μ F/DC80V)	
	C409, C417	CEAS101M25	CEAS101M25	Not Used	Not Used	
C410	CEAS471M25	CEAS471M25	Not Used	Not Used		
C411	CKCYF103Z50	CKCYF103Z50	Not Used	Not Used		
C412 (0.022 μ F/AC400V)	ACG1030	ACG1030	Not Used	Not Used		
C413 (0.01 μ F/AC250V)	ACG7020	ACG7020	Not Used	Not Used		
C415	CEAS221M16	CEAS221M10	CEAS221M16	CEAS221M16		
C416	Not Used	CEAS2R2M50	Not Used	Not Used	*2	
C422 (0.1 μ F/AC250V)	Not Used	Not Used	ACE-507	ACE7004	*2	
C423	CEAS470M25	Not Used	CEAS470M25	Not Used		
R333, R334	RD1/4PU392J	RD1/4PU272J	RD1/4PU392J	RD1/4PU392J		
R351-R354	RFA1/4PS470J	RD1/4PMF470J	RFA1/4PS470J	RFA1/4PS470J		
R403	RD1/2PM221J	Not Used	RD1/2PM221J	RD1/2PM221J		
R409	RS2LMF121J	RS2LMF121J	Not Used	Not Used		
R410	RD1/2PM270J	RD1/2PM270J	Not Used	Not Used		
R415 (2.2MΩ, 1/2W)	ACN-208	Not Used	ACN-208	Not Used		
R416	RD1/4PU332J	RD1/4PU332J	Not Used	Not Used		
R422	Not Used	RS3LMF221J	Not Used	Not Used	*2	
R4001	Not Used	Not Used	Not Used	RD1/4PU102J	*2	
△	1P AC Outlet	AKP1060	Not Used	AKP1060		
	JA203	PKN1004	PKN1004	Not Used	Not Used	

Note *2: Refer to " 5. SCHEMATIC AND PCB CONNECTION DIAGRAMS".

POWER SW. Assy

AWZ8095 and AWZ8094 have the same construction except for the following:

Mark	Symbol & Description	Part No.		Remarks
		AWZ8094	AWZ8095	
D876		BR3371XJ30A	Not Used	
S401		Not Used	ASG1035	*2
S876		ASG1034	Not Used	
C418 (0.01 μ F/AC250V)		Not Used	ACG7020	*2
R876		RD1/4PU331J	Not Used	

Note *2: Refer to " 5. SCHEMATIC AND PCB CONNECTION DIAGRAMS".

SX-255R, SX-205

TRANS Assy

AWZ8378 and AWZ8097 have the same construction except for the following:

Mark	Symbol & Description	Part No.		Remarks
		AWZ8097	AWZ8378	
	C952-C954	Not Used	CKCYF103Z50	*2
	R952	Not Used	RD1/4PU100J	*2
	J36	Not Used	DB015EB0	*2

Note *2: Refer to "5. SCHEMATIC AND PCB CONNECTION DIAGRAMS".

PCB PARTS LIST

Mark No.	Description	Parts No.
----------	-------------	-----------

PRIMARY ASSY (AWZ8381 for SX-205/SDXJ)

OTHERS

J24	LEAD WIRE UNIT	DB420EB0
J25	LEAD WIRE UNIT	DB220EB0
J26	LEAD WIRE UNIT	DB920EB0
J27	LEAD WIRE UNIT	DB820EB0
J28	LEAD WIRE UNIT	DB520EB0

11. SPECIFICATIONS

Amplifier Section

Continuous Average Power Output is 100 watts* per channel, min., at 8 ohms from 40 Hertz to 20,000 Hertz with no more than 0.9% total harmonic distortion.**

[Multi-voltage model only]

Continuous Power Output (DIN)	
1 kHz, T.H.D. 1%, 8 Ω	115 W+115 W
Dynamic Power (2 Ω/4 Ω/8 Ω)	260 W/ 220 W/ 150 W
Input (Sensitivity/Impedance)	200 mV/47 kΩ
Output (Level/Impedance)	
TAPE 2 REC, TAPE 1/VCR REC	200mV/2.2 kΩ
Frequency Response	10 Hz to 100 kHz ± 3 dB
BASS	100 Hz, ± 10 dB
TREBLE	10 kHz, ± 10 dB
SUPER BASS	80 Hz, +8 dB
Signal-to-Noise Ratio (IHF, shortcircuited, A network)	
PHONO MM	72 dB
CD, TAPE 1/VCR, TAPE 2, LD/DVD	96 dB

FM Tuner Section

Frequency range	87.5 MHz to 108 MHz
Usable Sensitivity	11.2 dBf, IHF (1.0 μV/ 75 Ω)
50 dB Quieting Sensitivity	
MONO	16.8 dBf (1.9 μV/ 75 Ω)
STEREO	38.6 dBf (23.3 μV/ 75 Ω)
Signal-to-Noise Ratio	
MONO	76 dB (at 85 dBf)
STEREO	72 dB (at 85 dBf)
Distortion	
MONO	0.5% (1 kHz)
STEREO	0.5% (1 kHz)
Alternate Channel Selectivity	60dB (400 kHz)
Stereo Separation	40dB (1 kHz)
Frequency Response	30 Hz to 15 kHz (± 1 dB)
Antenna Input	75 unbalanced

AM Tuner Section

Frequency range	
When 10 kHz step	530 kHz to 1,700 kHz
When 9 kHz step	531 kHz to 1,602 kHz
Sensitivity	
IHF, Loop antenna	350 μV/m
Selectivity	25 dB
Signal-to-Noise Ratio	50 dB
Antenna	AM Loop Antenna

Miscellaneous

Power Requirements	
U.S. and Canadian models	AC 120 Volts, 60 Hz
Multi-voltage model	AC 110V/120V - 127V /220V/240V (switchable), 50/60 Hz
Power Consumption	
U.S. and Canadian models	190 W (UL), 330 VA (CSA)
Multi-voltage model	520 W
AC Outlet	SWITCHED x 1 : 100W MAX
Dimensions	420 (W) x 140 (H) x 298 (D) mm
	16-9/16 (W) x 5-8/16 (H) x 11-12/16 (D) in
Weight (without package)	
U.S. and Canadian models	6.6 kg (14 lb 9 oz)
Multi-voltage model	6.8 kg

Furnished Parts

FM Antenna	1
AM Loop Antenna	1
Operating Instructions [SX-255R]	1
Remote control unit	1
Dry cell batteries (size "AA" (R6P))	2

* Measured pursuant to the Federal Trade Commission's Trade Regulation rule on Power Output Claims for Amplifiers.

** Measured By Audio Spectrum Analyzer.

NOTE:

Specifications and design subject to possible modification without notice due to improvements.

12. PANEL FACILITIES

• The illustration shows SX-255R/SX-205 multi-voltage model.

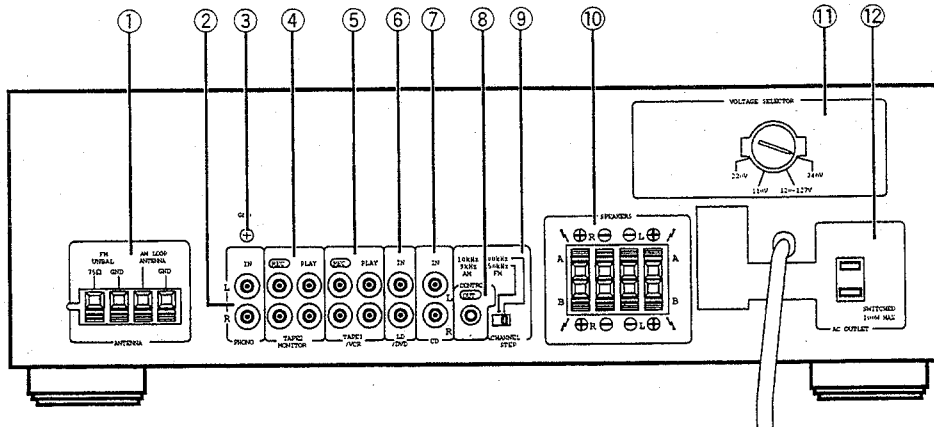

① FM/AM ANTENNA terminals

Use these antenna terminals for receiving FM and AM broadcasts.

② PHONO jacks

Connect to the output cables from a turntable.

③ GND terminal

Connect to the ground lead of a turntable.
Use a screwdriver to connect with the ground terminal.

④ TAPE 2 MONITOR jacks

Connect these jacks to a cassette deck.

⑤ TAPE 1/VCR jacks

Connect these jacks to a cassette deck or video cassette recorder.

⑥ LD/DVD jacks

Connect to the output jacks of an LD player, DVD player or another unit.

⑦ CD jacks

Connect to the output jacks of a compact disc player.

⑧ CONTROL OUT jacks (SX-255R only)

Connect this jack to other Pioneer components bearing the  mark when using the remote control of this unit to control the other components.

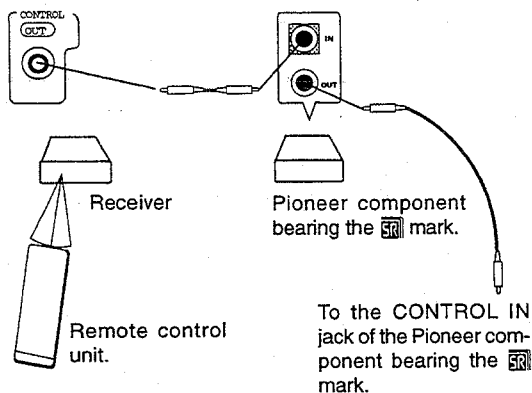

To the CONTROL IN jack of the Pioneer component bearing the  mark.

⑨ CHANNEL STEP switch (multi-voltage model only)

⑩ SPEAKERS terminals

A : Connect to a first set of speakers.
B : Connect to a second set of speakers.

NOTE:

No sound will be heard through the speakers when both A and B buttons are depressed if only one set of speakers has been connected to either A or B SPEAKERS terminals.

⑪ VOLTAGE SELECTOR (multi-voltage model only)

⑫ AC OUTLET

AC OUTLET

[U.S. and Canadian models] SWITCHED 100 W (0.8 A) MAX

Power supplied through this outlet is turned on and off by the receiver's POWER switch. Electrical power consumption of the connected equipment should not exceed 100 W (0.8 A MAX). The equipment should be disconnected by removing the mains plug from the wall socket when not in regular use, e.g. when on vacation.

[Multi-voltage model] SWITCHED 100 W MAX

Power supplied through this outlet is turned on and off by the receiver's POWER switch. Electrical power consumption of the connected equipment should not exceed 100 W. The equipment should be disconnected by removing the mains plug from the wall socket when not in regular use, e.g. when on vacation.

CAUTION

DO NOT CONNECT MONITOR OR TV SET.

NOTE:

Do not connect appliances with high power consumption such as heaters, irons, or television sets to the AC OUTLET, in order to avoid overheating or fire risk. This can cause the receiver to malfunction.

SX-255R, SX-205

• The illustration shows the SX-255R.

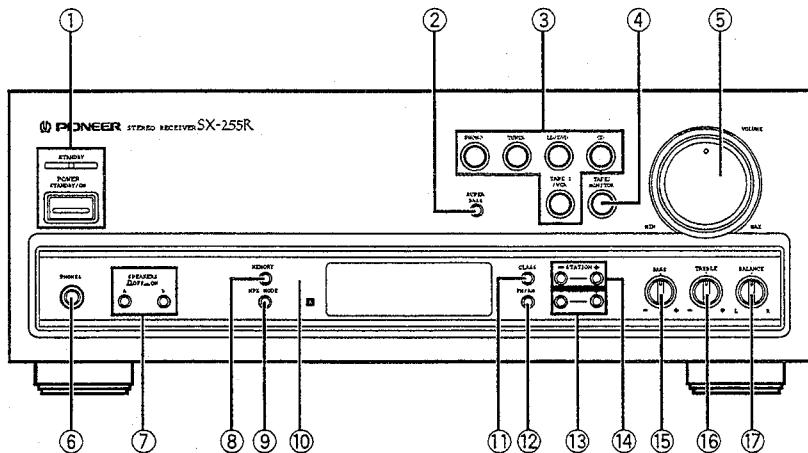

① POWER STANDBY/ON switch/STANDBY indicator (SX-255R)

This is the switch for electric power.

ON: When set to the ON position, power is supplied and the unit becomes operational.

STANDBY: When set to the STANDBY position, the main power flow is cut and the unit is no longer fully operational. A minute flow of power feeds the unit to maintain operation readiness. The STANDBY indicator is illuminated during standby mode.

• The accessory remote control unit can also be used to operate STANDBY/ON.

NOTE:

When the power is initially turned ON, muting will be applied to prevent sound from being output for approx. 5 seconds.

① POWER switch/POWER indicator (SX-205)

When this switch is pressed, power is supplied to the unit and the indicator lights up.

Press the switch again to turn power OFF.

[Timer ON/OFF possible]

When the unit is switched ON, ON/OFF control can be performed by means of the optional timer.

NOTE:

When the power is initially turned ON, muting will be applied to prevent sound from being output for approx. 5 seconds.

② SUPER BASS button

When this button is pressed, the bass sound will be emphasized.

③ Function buttons

Use to select playback source.

[PHONO]

Press when listening to record playback on a turntable.

[TUNER]

Press when listening to AM or FM broadcasts with a tuner.

[LD/DVD]

Press when listening to programs from a component connected to the LD/DVD jacks.

[CD]

Press when listening to compact disc playback with a CD player.

[TAPE 1/VCRR]

Press when listening to tape playback on cassette deck 1 or on a video cassette recorder.

④ TAPE 2 MONITOR button

Press when listening to tape playback and monitor the recording sound with the cassette deck 2.

⑤ VOLUME control

Use to adjust volume level.

⑥ PHONES jack

Connect the plug on your headphones to this jack. To listen to a program through the headphones, set both SPEAKERS A and B switches to the OFF position.

⑦ SPEAKERS (OFF, ON) buttons

These are used to select the speaker through which you wish to listen.

A: When the speakers connected to the A terminals are in use.

B: When the speakers connected to the B terminals are in use.

• Turn both A and B speakers to the OFF position when only the headphones are in use.

NOTE:

No sound will be heard through the speakers when both A and B buttons are pressed if only one set of speakers has been connected to either A or B SPEAKERS terminals.

⑧ MEMORY button

When the unit is in the frequency display mode, pressing this button will result in the memorization of the current broadcast band, reception frequency, CLASS and FM MPX mode.

⑨ MPX MODE selector button

Use to select the auto stereo mode or monaural mode when listening to FM broadcasts. The monaural mode has been selected when the MONO indicator is lighted.

Auto stereo mode:

Normally leave in this mode for reception. When a stereo FM broadcast is received, it will be automatically reproduced in stereo sound.

Monaural mode:

When receiving distant stations or stations with weak broadcast signals, the input signal may be weak, thus resulting in increased noise during FM stereo broadcasts. In this event, setting the receiver to the monaural mode will reduce the noise. In this case, however, FM stereo broadcasts will be reproduced in monaural sound.

NOTE:

This button has no effect on reception of AM broadcasts.

⑩ Remote sensor window (SX-255R)

⑪ CLASS button

Use to switch between preset memory classes 1 to 3. In each class, one station can be memorized in each of the 1 to 10 stations, enabling a total of 30 stations to be memorized.

⑫ FM/AM selector button

This button is used to select either AM or FM reception.

⑬ TUNING buttons (-,+)

+: The FM or AM band is scanned in the direction of increasing frequency.

-: The opposite operation to that of the + button takes place.

⑭ STATION buttons (-,+)

+: Stations change in order in the upward direction.

-: Stations change in order in the downward direction.

⑮ BASS tone control

Use to adjust low-frequency tone. The center position is the flat (normal) position. When turned to the right, low-frequency tones are emphasized.

⑯ TREBLE tone control

Use to adjust high-frequency tone. The center position is the flat (normal) position. When turned to the right, high-frequency tones are emphasized.

⑰ BALANCE control

Should normally be left in the center position. Adjust balance if the sound is louder from one of the speakers. If the right side is louder, turn toward the L position and if the left side is louder, turn toward the R position.

DISPLAY section

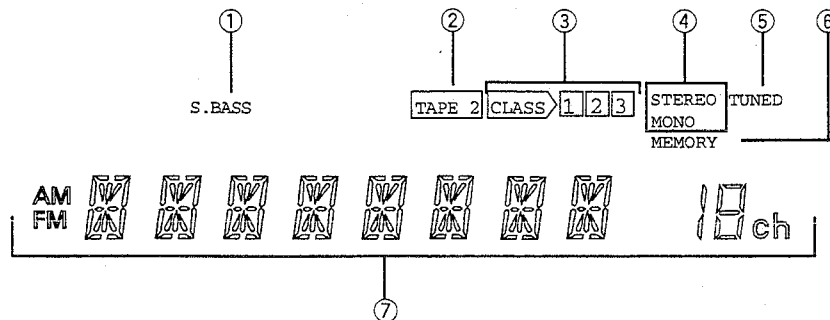

① S.BASS indicator

Lights up when the SUPER BASS button is pressed.

② TAPE 2 monitor indicator

Lights up when the function buttons is set to TAPE 2 MONITOR on.

③ CLASS 1 2 3 indicator

Indicates the class selected by the CLASS button. The current CLASS is displayed.

④ STEREO/MONO indicator

MONO: Lights up when the FM MONO mode is selected with the MPX MODE button.

STEREO: Lights up when a stereo FM broadcast is being received.

⑤ TUNED indicator

Lights up when a station is tuned.

⑥ MEMORY indicator

⑦ Character indicator