

LH3 Torque & Multi-turn Position Sensor



SX-4472

Features:

- 5° sensor with torque, multi-turn position output, and flex circuit harness
- Ideally suited for demanding electric power steering systems

Electrical

Torque Signal Linearity	±3%
Torque Hysteresis	0.5% maximum
Torque Signal Microgradient	±30% of theoretical slope over 0.4° interval
Torque Sensed Angle	±5°
Position Signal Linearity (P1, P2)	±1.5%
Position Signal Microgradient (P1, P2)	±30% of theoretical slope over 2° interval
Multi-turn Position Accuracy (P3)	±3%
Multi-turn Position Sensed Angle	±720°
Total Resistance	438 Ω ±30%

Mechanical

Torque Mechanical Travel	±11.4°
Position Mechanical Travel	Continuous
Turning Torque (rotor to rotor)	0.03 NM maximum
Turning Torque (position rotor to housing)	0.06 NM maximum
Weight	grams maximum

Environmental

Operating Temperature Range	-40°C to +85°C
Shock	14 ms half-sine at 300 m/s ²
Vibration	10 to 55 Hz with 1 mm P-P constant displacement, 120 hours each of 3 planes
Torque Rotational Life	1 million cycles
Position Rotational Life	1 million cycles
Storage Temperature Range	-40°C to +105°C



General Note
TT Electronics reserves the right to make changes in product specification without notice or liability. All information is subject to TT Electronics' own data and is considered accurate at time of going to print.

TT Electronics | BI Technologies
Circulo de la Amistad #102 PIMSA IV Mexicali B.C. Mexico C.P 21210
Ph: + 1 (714) 447-2345
www.ttelectronics.com/bi-technologies

Output Charts

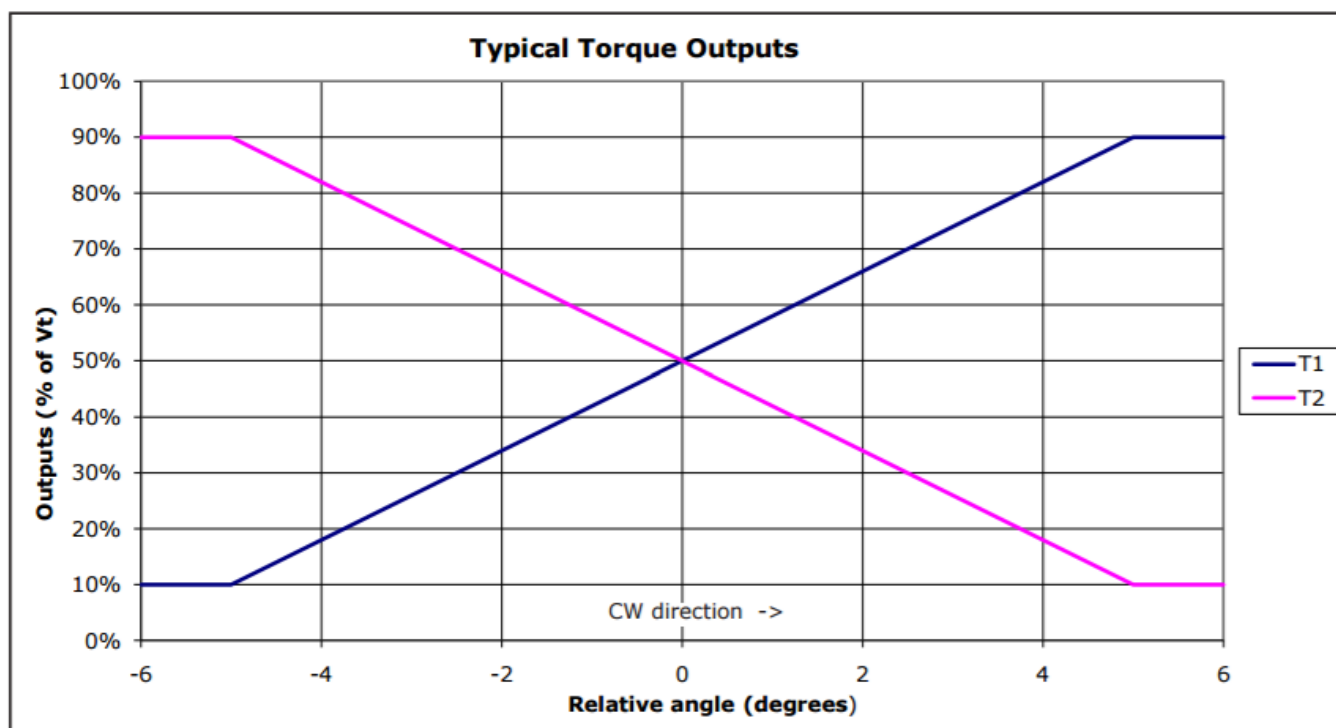
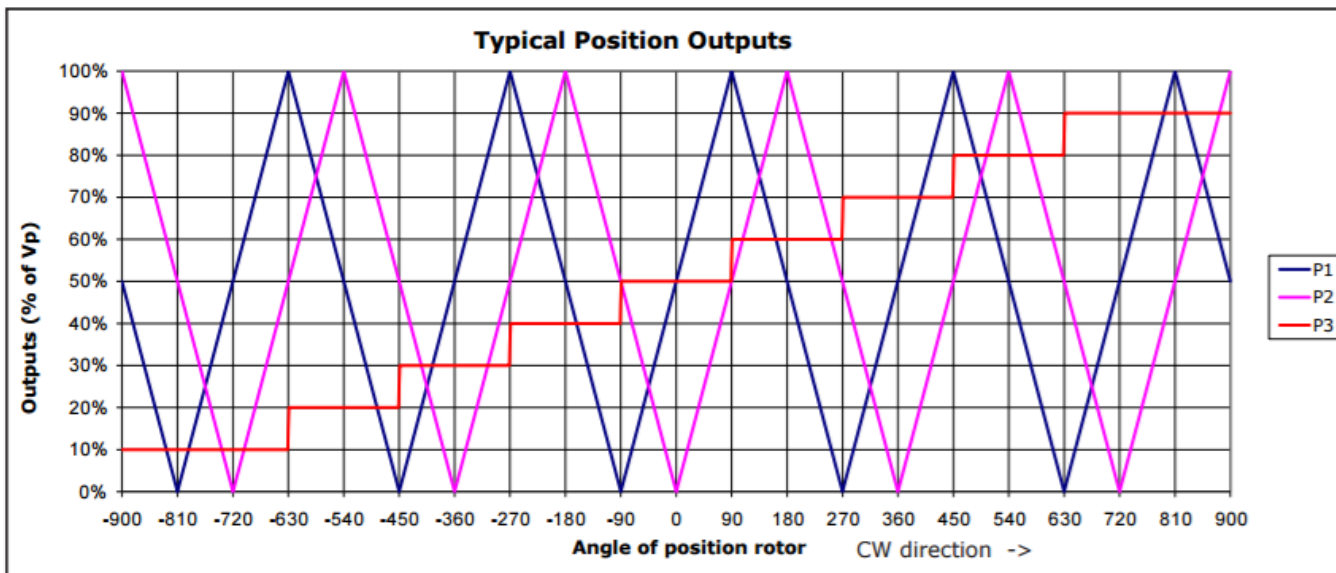

LH3 Torque & Multi-turn Position Sensor



Outline Drawing

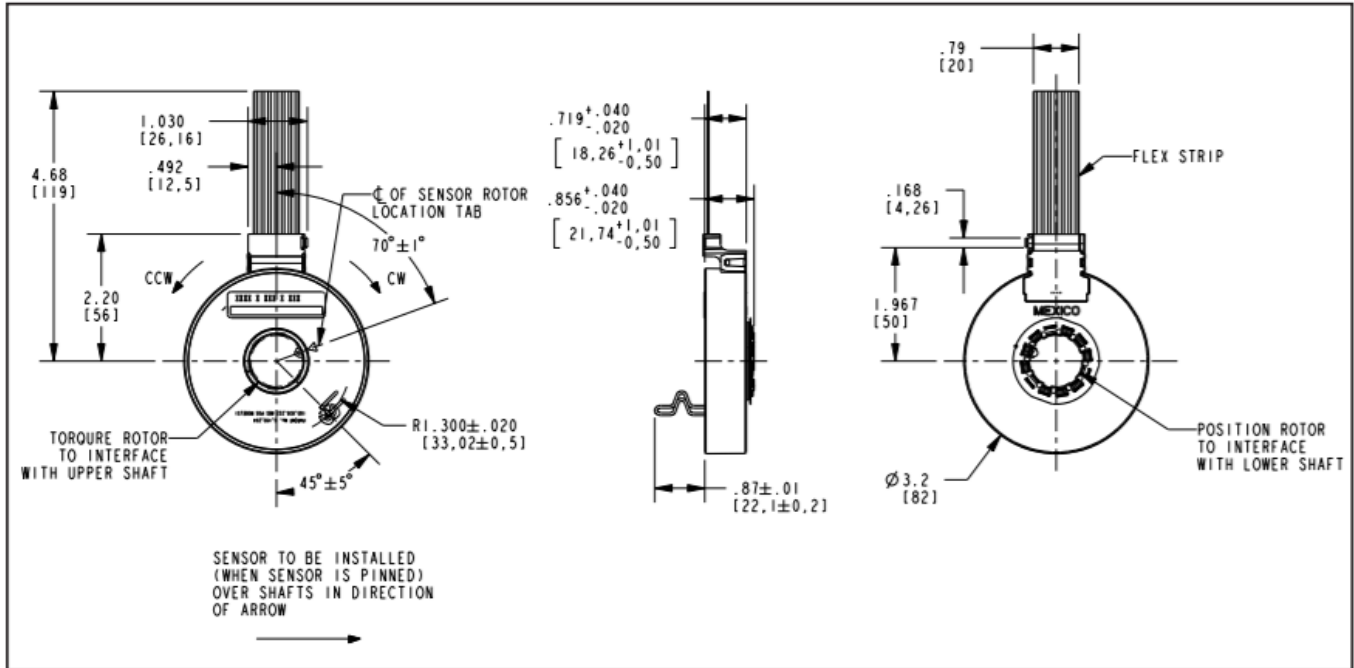

Tolerances ±0.25 mm unless otherwise specified. See drawing # 122-4472-80 for details.

Barcode Label

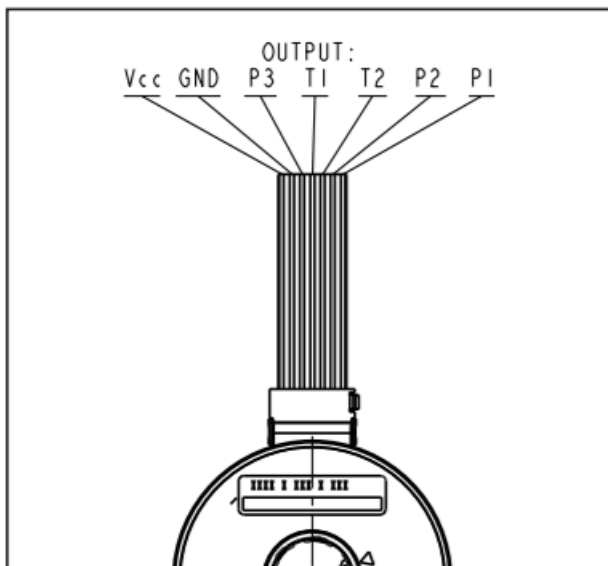

Barcode Label

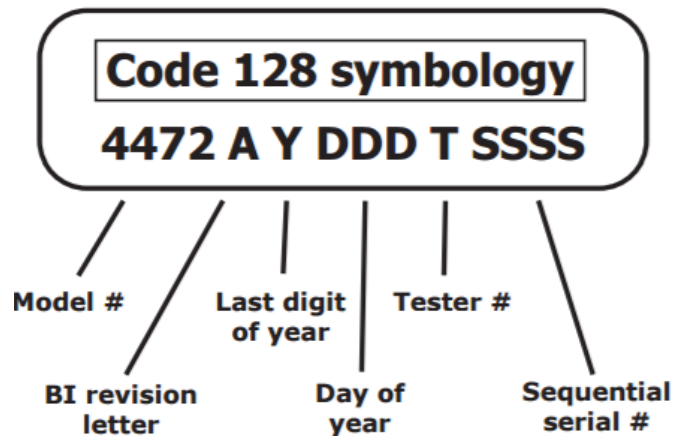

General Note
TT Electronics reserves the right to make changes in product specification without notice or liability. All information is subject to TT Electronics' own data and is considered accurate at time of going to print.

TT Electronics | BI Technologies
Circulo de la Amistad #102 PIMSA IV Mexicali B.C. Mexico C.P 21210
Ph: + 1 (714) 447-2345
www.ttelectronics.com/bi-technologies

Recommended Interface

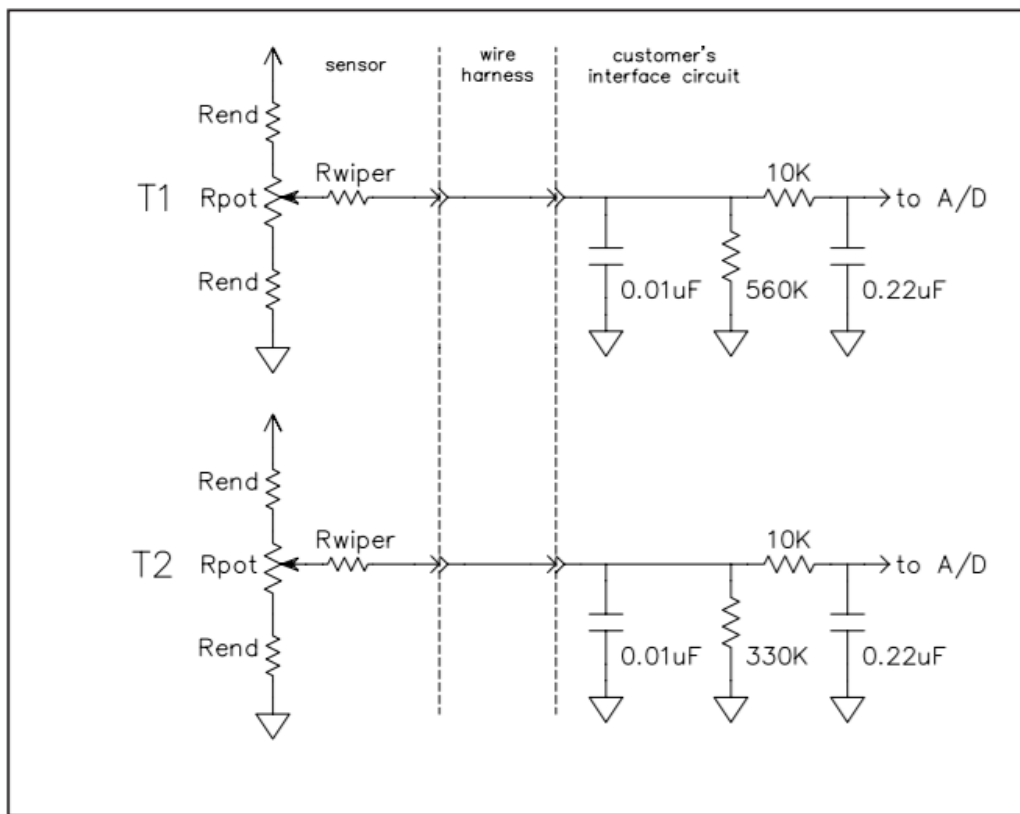
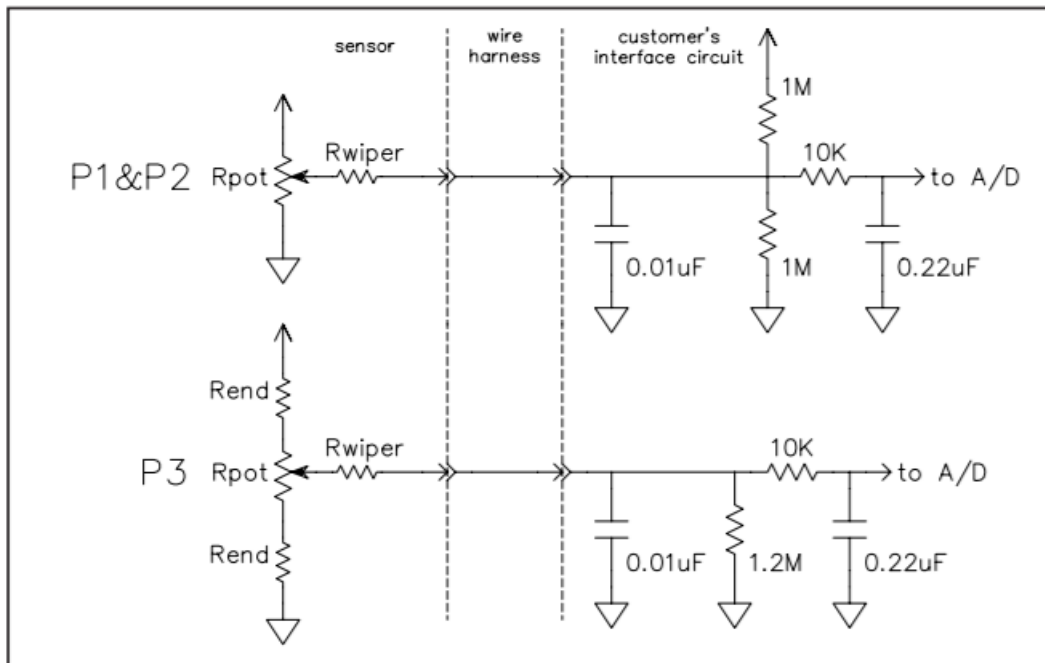

General Note
 TT Electronics reserves the right to make changes in product specification without notice or liability. All information is subject to TT Electronics' own data and is considered accurate at time of going to print.

TT Electronics | BI Technologies
 Circulo de la Amistad #102 PIMSA IV Mexicali B.C. Mexico C.P 21210
 Ph: + 1 (714) 447-2345
www.ttelectronics.com/bi-technologies