

GENERAL DESCRIPTION

The SX8653 is a touch controller for 4 or 5 wire resistive touchscreen. With 4-wire touchscreen, the multitouch feature enables a completely different user interaction. It enables detection of 2 fingers on the touchscreen and several gestures like rotation and pinch/ stretch.

It features a wide input supply range from 1.65V to 3.7V and low power modes to preserve current when the screen is unintentionally touched.

To compute touch screen X-Y coordinates and touch pressure with precision, a low power 12-bit analog-digital converter is activated with the possibility to enable on-chip data averaging processing algorithms to reduce host activity and suppress system noise.

The touch screen controller inputs have been specially designed to provide robust on-chip ESD protection of up to $\pm 15\text{kV}$ in both HBM and Contact Discharge, and eliminates the need for external protection devices. The SX8653 is controlled by a high speed SPI™ serial interface.

The SX8653 is available in a 4.0 mm x 3.0 mm 14-DFN package and a 1.5 mm x 2.0 mm wafer level chip scale package (WLCSP) for space conscience applications.

APPLICATIONS

- ◆ DSC, DVR, Cell Phones
- ◆ PDA, Pagers
- ◆ Point-of-Sales Terminals
- ◆ Touch-Screen Monitors

ORDERING INFORMATION

Part Number	Package (Dimension in mm)	Marking
SX8653ICSTR1 ¹	12 - Ball WLCSP (1.5x2.0)	NB2A
SX8653IWLTR1 ¹	14 - Lead DFN (4.0x 3.0)	NB2A

1. 3000 Units / reel

KEY PRODUCT FEATURES

- ◆ Extremely Low Power Consumption: 23uA@1.8V 8kSPS
- ◆ Support Multi-touch operation (4-wire)
- ◆ Superior On-chip ESD Protection
 - ⇒ $\pm 15\text{kV}$ HBM (X+,X-,Y+,Y-)
 - ⇒ $\pm 2\text{kV}$ CDM
 - ⇒ $\pm 25\text{kV}$ Air Gap Discharge
 - ⇒ $\pm 15\text{kV}$ Contact Discharge
 - ⇒ $\pm 300\text{V}$ MM
- ◆ Pin-compatible with SX8652
- ◆ Single 1.65V to 3.7V Supply/Reference
- ◆ 4-Wire or 5-Wire Resistive Touch Screen Interface
- ◆ Integrated Preprocessing Block to Reduce Host Loading and Bus Activity
- ◆ Four User Programmable Operation Modes provides Flexibility to address Different Application Needs
 - ⇒ Manual, Automatic, Pen Detect, Pen Trigger
- ◆ Precision, Low Noise, High Speed 12-bit SAR ADC Operating At 74k SPS
- ◆ Throughput: 5000 (X-Y) coordinates/second (c/s) with 7-Sample Averaging
- ◆ Low Power Shut-Down Mode < 1uA
- ◆ SPI™ Serial Interface
- ◆ Touch Pressure Measurement (4-Wire)
- ◆ Auxiliary Input (4-Wire) For Alternate ADC Input or Start of Conversion Trigger
- ◆ Hardware & Software reset
- ◆ -40°C to +85°C operation
- ◆ Pb-Free, Halogen Free, RoHS/WEEE compliant product
- ◆ Windows CE 6.0, Linux Driver Support Available
- ◆ Packages: 14-LD (4.0 mm x 3.0 mm) DFN
12-Ball (1.5 mm x 2.0 mm) WLCSP

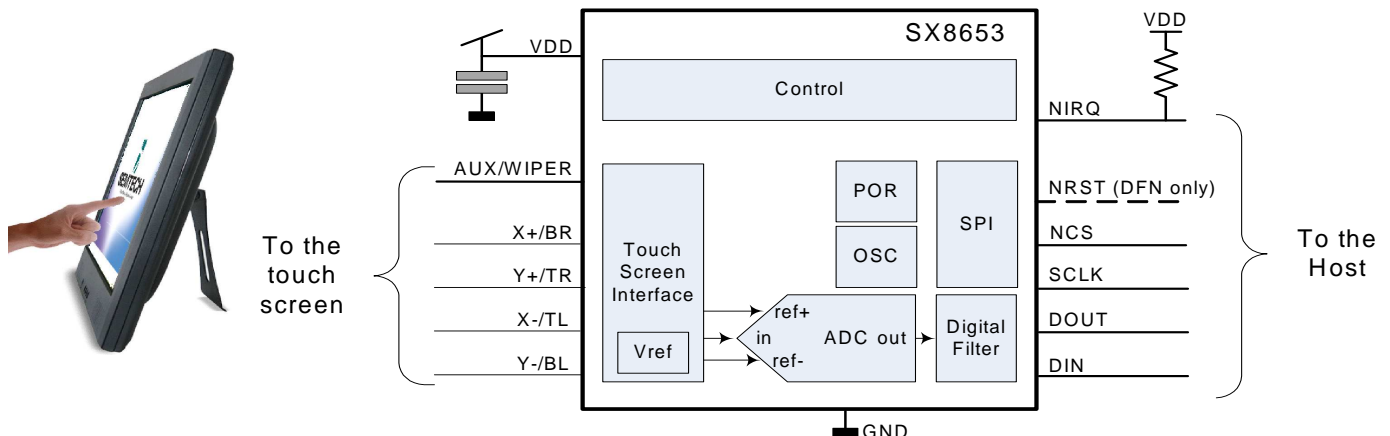

Table of contents

Section	Page
1. General Description	4
1.1. DFN Pinout Diagram and Marking Information (Top View).....	4
1.2. WLCSP Pinout Diagram and Marking Information (Top View)	4
1.3. Pin Description.....	5
1.4. Simplified Block Diagram	5
2. Electrical Characteristics	6
2.1. Absolute Maximum Ratings	6
2.2. Recommended Operating Conditions.....	6
2.3. Thermal Characteristics	6
2.4. Electrical Specifications	7
2.5. Host Interface Specifications	9
2.6. Host Interface Timing Waveforms.....	9
3. Functional Description	10
3.1. General Introduction	10
3.2. Device Interface and ESD protection.....	11
3.2.1. Touchscreen interface.....	11
3.2.2. Host Interface and Control Pins	11
4. 4-wire Touch Screen Detailed Description	12
4.1. Touch Screen Operation.....	12
4.2. Coordinates Measurement.....	12
4.3. Pressure Measurement.....	13
4.4. Pen Detection	13
4.5. Double touch measurement.....	14
5. 5-wire Touch Screen Detailed Description	15
5.1. Touch Screen Operation.....	15
5.2. Coordinates Measurement.....	15
5.3. Pen Detection	15
6. Data Processing	16
7. Power-Up, Reset	16
8. Modes of Operation	16
8.1. MANual Mode	17
8.2. AUTOMATIC mode	17
8.3. PENDET Mode	18
8.4. PENTRIG Mode	18
9. Host Interface	20
9.1. SPI Read/Write Registers	20
9.2. SPI Reading Channel Data.....	20
9.3. SPI implementation and multiple Read/Write	21
9.4. Invalid Qualified Data.....	22

Table of contents

Section	Page
9.5. Register Map.....	23
9.6. SX8653 register	24
10. Application Information	25
10.1. Acquisition Setup	25
10.2. Channel Selection.....	25
10.3. Noise Reduction.....	25
10.3.1. POWDLY.....	25
10.3.2. SETDLY	26
10.4. AUX Input - 4-wire touchscreen only	26
10.5. Interrupt Generation.....	26
10.6. Coordinate Throughput Rate	26
10.6.1. SPI Communication Time	26
10.6.2. Conversion Time	27
10.7. ESD event.....	27
11. Multi-Touch Gestures with 4-wire touchscreen.....	28
11.1. Zoom Gesture	28
11.2. Rotate Gesture.....	28
12. Packaging Information	29
12.1. DFN Package.....	29
12.2. WLCSP Package	30

1. General Description

1.1. DFN Pinout Diagram and Marking Information (Top View)

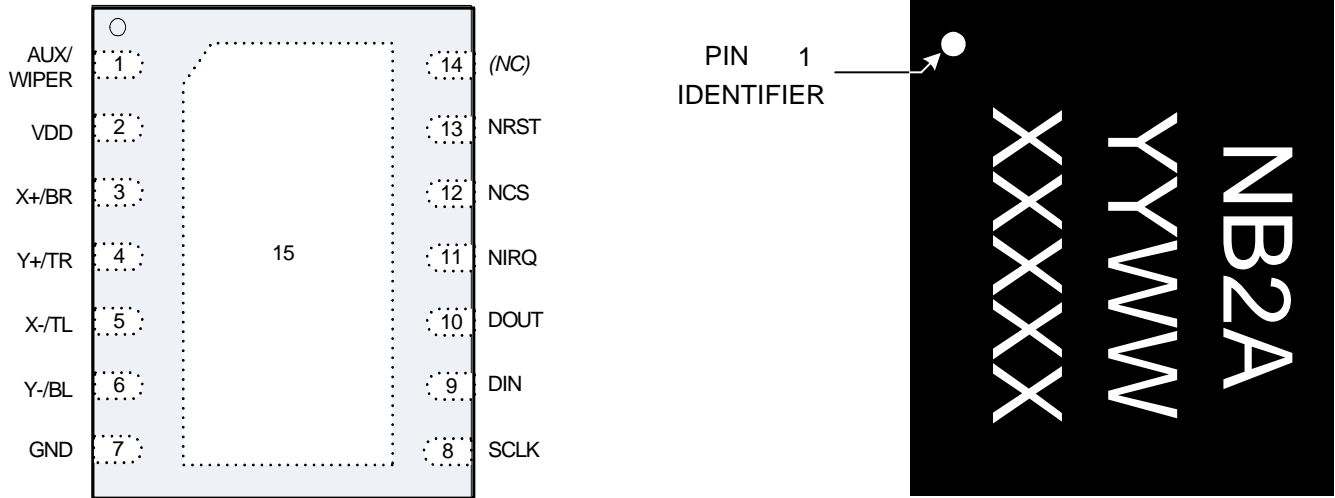

Figure 1. SX8653 DFN Top View, Pad on Bottom Side

YYWW: date code

XXXXXX: Lot Number

1.2. WLCSP Pinout Diagram and Marking Information (Top View)

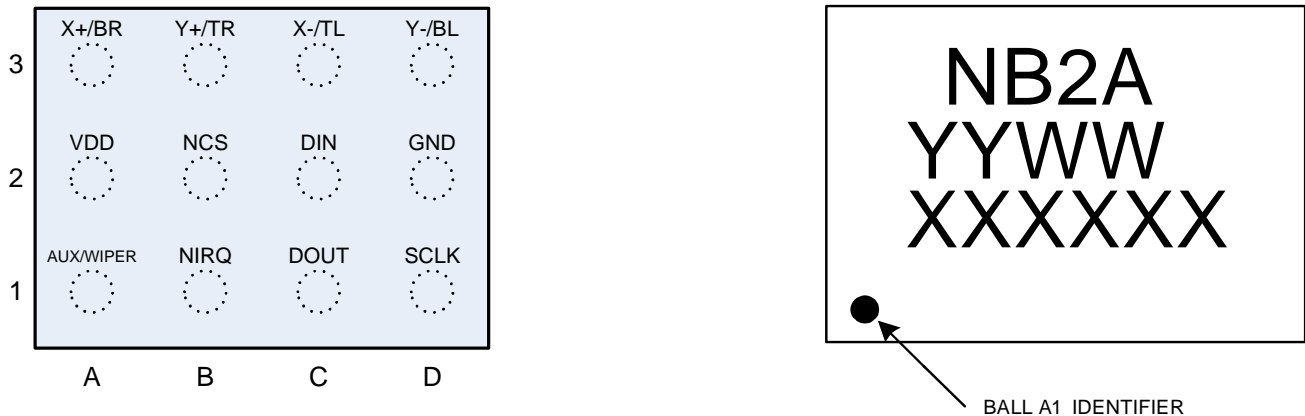

Figure 2. SX8653 WLCSP Top View, Solder Bumps on Bottom Side

YYWW: date code

XXXXXX: Lot Number

1.3. Pin Description

Pin Number #	Name	Type	Description
DFN	WLCSP		
1	A1	AUX/WIPER	Digital Input / Analog Input Conversion Synchronization (4-wire) or Analog Auxiliary Input (4-wire) / Wiper Input (5-wire)
2	A2	VDD	Power Input Input power supply, connect to a 0.1uF capacitor to GND
3	A3	X+/BR	Analog IO X+ Right electrode (4-wire) / Bottom Right (5-wire) channel
4	B3	Y+/TR	Analog IO Y+ Top electrode (4-wire) /Top Right (5-wire) channel
5	C3	X-/TL	Analog IO X- Left electrode (4-wire) /Top Left (5-wire) channel
6	D3	Y-/BL	Analog IO Y- Bottom electrode (4-wire) /Bottom Left (5-wire) channel
7	D2	GND	Ground Ground
8	D1	SCLK	Digital Input SPI Serial Clock Input
9	C2	DIN	Digital Output SPI Serial Data Input
10	C1	DOUT	Digital Output SPI Serial Data Output
11	B1	NIRQ	Digital Output, open drain Interrupt Request Output, Active low, Need external pull-up
12	B2	NCS	Digital Input SPI Chip Select Input, Active low
13	-	NRST	Digital Input DFN package only, Reset Input, Active low, Internal pull-up resistor
14	-	(NC)	Not Connected
15	-	GND	Power input Backside Ground

Table 1. Pin description

1.4. Simplified Block Diagram

The SX8653 simplified block diagram is shown in Figure 3.

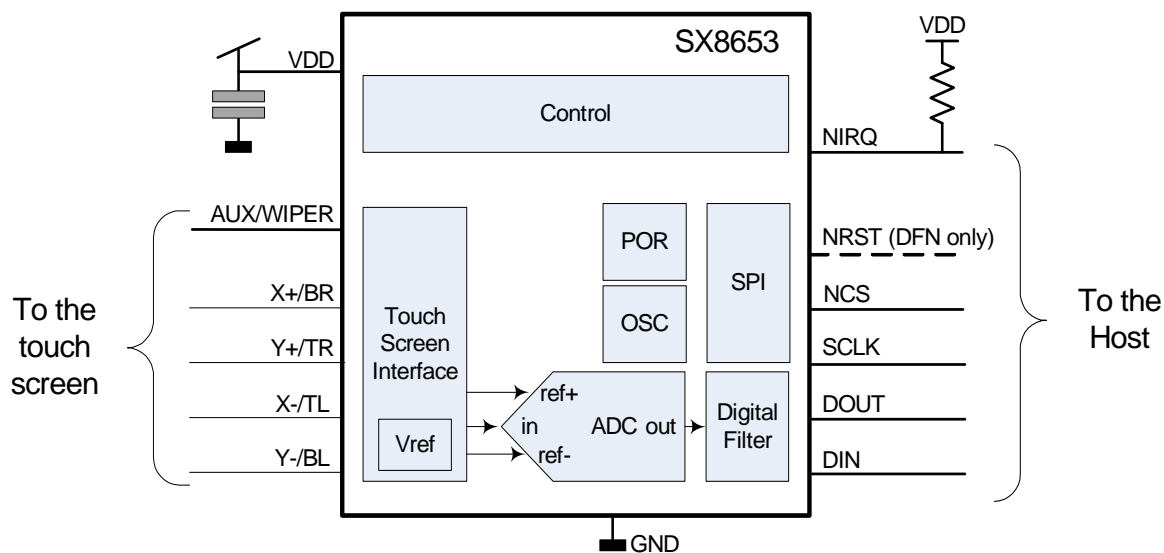

Figure 3. Simplified block diagram of the SX8653

2. Electrical Characteristics

2.1. Absolute Maximum Ratings

Stresses above the values listed in “Absolute Maximum Ratings” may cause permanent damage to the device.

This is a stress rating only and functional operation of the device at these, or any other conditions beyond the “Recommended Operating Conditions”, is not implied. Exposure to absolute maximum rating conditions for extended periods may affect device reliability.

Parameter	Symbol	Min.	Max.	Unit
Supply Voltage	V_{DDABS}	-0.5	3.9	V
Input voltage (non-supply pins)	V_{IN}	-0.5	3.9	V
Input current (non-supply pins)	I_{IN}		10	mA
Operating Junction Temperature	T_{JCT}		125	°C
Reflow temperature	T_{RE}		260	°C
Storage temperature	T_{STOR}	-50	150	°C
ESD HBM (Human Body Model)	High ESD pins: X+/BR, X-/TL, Y+/TR, Y-/BL, Aux/Wiper	ESD _{HBM1}	± 15 ⁽ⁱ⁾	kV
			± 8 ⁽ⁱⁱ⁾	kV
	All pins except high ESD pins	ESD _{HBM2}	± 2	kV
ESD (Contact Discharge)	High ESD pins: X+/BR, X-/TL, Y+/TR, Y-/BL, Aux/Wiper	ESD _{CD}	± 15	kV
Latchup ⁽ⁱⁱⁱ⁾	I_{LU}	± 100		mA

Table 2. Absolute Maximum Ratings

(i) Tested to TLP (10A)

(ii) Tested to JEDEC standard JESD22-A114

(iii) Tested to JEDEC standard JESD78

2.2. Recommended Operating Conditions

Parameter	Symbol	Min.	Max	Unit
Supply Voltage	V_{DD}	1.65V	3.7	V
Ambient Temperature Range	T_A	-40	85	°C

Table 3. Recommended Operating Conditions

2.3. Thermal Characteristics

Parameter	Symbol	Min.	Max	Unit
Thermal Resistance with DFN package - Junction to Ambient ⁽ⁱⁱⁱ⁾	θ_{JA}		39	°C/W
Thermal Resistance with WLCSP package - Junction to Ambient ⁽ⁱⁱⁱ⁾	θ_{JA}		65	°C/W

Table 4. Thermal Characteristics

(iii) θ_{JA} is calculated from a package in still air, mounted to 3" x 4.5", 4 layer FR4 PCB with thermal vias under exposed pad (if applicable) per JESD51 standards.

2.4. Electrical Specifications

All values are valid within the recommended operating conditions unless otherwise specified.

Parameter	Symbol	Conditions	Min.	Typ	Max	Unit
Current consumption						
Mode = MANUAL	I_{pwd}	Converter stopped, pen detection off, SPI listening, OSC stopped		0.4	1	μA
Mode = PENDET	I_{pndt}	Converter stopped, pen detection activated, device generates interrupt upon detection, SPI listening, OSC stopped		0.4	1	μA
Mode =PENTRIG	I_{pntr}	Converter stopped, pen detection activated, device starts conversion upon pen detection. SPI listening, OSC stopped		0.4	1	μA
Mode=AUTO	I_{auto}	Converter stopped, pen detection off, SPI listening, OSC on, timer on		1.5		μA
Operation @8kSPS, VDD=1.8V	I_{opl}			23	50	μA
Operation @42kSPS, VDD=3.3V	I_{oph}			105	140	μA
Digital I/O						
High-level input voltage	V_{IH}		$0.8V_{DD}$		$V_{DD}+0.2$	V
Low-level input voltage	V_{IL}		$V_{SS}-0.3$		$0.2V_{DD}$	V
Hysteresis	V_{HysLow}	$V_{DD} > 2V$		$0.05 V_{DD}$		V
	$V_{HysHigh}$	$V_{DD} < 2V$		$0.1 V_{DD}$		V
Output Logic High	V_{OH}	$I_{OH} > -2mA$	$0.8V_{DD}$			
Output Logic Low	V_{OL}	$I_{OL} < 2mA$	0		0.4	V
Input leakage current	I_I	CMOS input			± 1	μA
High ESD Input - Output capacitance	$C_{X+BR}, C_{X-TL}, C_{Y+TR}, C_{Y-BL}, C_{AUX}$			50		pF
Input - Output capacitance	$C_{NRST}, C_{NIRQ}, C_{NCS}, C_{DIN}, C_{DOUT}, C_{SCLK}$			5		pF

Table 5. Electrical Specifications

ADVANCED COMMUNICATIONS & SENSING
DATASHEET

Parameter	Symbol	Conditions	Min.	Typ	Max	Unit
Startup						
Power-up time	t_{por}	Time between rising edge VDD and rising NIRQ			1	ms
ADC						
Resolution	A_{res}		12			bits
Offset	A_{off}			± 1		LSB
Gain error	A_{ge}	At full scale		0.5		LSB
Differential Non Linearity	A_{dnl}			± 1		LSB
Integral Non Linearity	A_{inl}			± 1.5		LSB
Resistors						
X+, X-, Y+, Y- resistance	R_{chn}	Touch Pad Biasing Resistance		5		Ohm
Pen detect resistance	R_{PNDT_00}	$R_{PNDT} = 0$		100		kOhm
	R_{PNDT_01}	$R_{PNDT} = 1$		200		kOhm
	R_{PNDT_10}	$R_{PNDT} = 2$		50		kOhm
	R_{PNDT_11}	$R_{PNDT} = 3$		25		kOhm
External components						
Capacitor between VDD, GND	C_{vdd}	Type 0402, tolerance +/-50%		0.1		μF

Table 5. Electrical Specifications

2.5. Host Interface Specifications

Parameter	Symbol	Condition	Min	Typ	Max	Unit
SPI TIMING SPECIFICATIONS ⁽ⁱ⁾						
SCLK Clock Frequency Duty Cycle	f_{SCLK} duty		40		5000 60	kHz %
NCS edge to first SCLK "↑"	T_{CSS}		50			ns
NCS edge to DOUT Low	T_{DCD}				100	
SCLK High Pulse Width	T_{CKH}		80			
SCLK Low Pulse Width	T_{CKL}		80			
Data Setup Time	T_{DS}		40			
Data Valid to SCLK Hold Time	T_{DH}		70			
Data Output Delay after SCLK "↓"	T_{DOD}				70	
NCS "↑" to SCLK Ignored	T_{CSI}		50			
NCS "↑" to DOUT Hi-Z state	T_{CCZ}				90	
NCS Hold Time	T_{CSW}		150			

(i) All timing specifications refer to voltage levels (50% VDD, V_{OH} , V_{OL}) defined in Table 6 unless otherwise mentioned.

Table 6. Host Interface Specifications

2.6. Host Interface Timing Waveforms

Figure 4. SPI Timing Waveform

3. Functional Description

3.1. General Introduction

This section provides an overview of the SX8653 architecture, device pinout and a typical application.

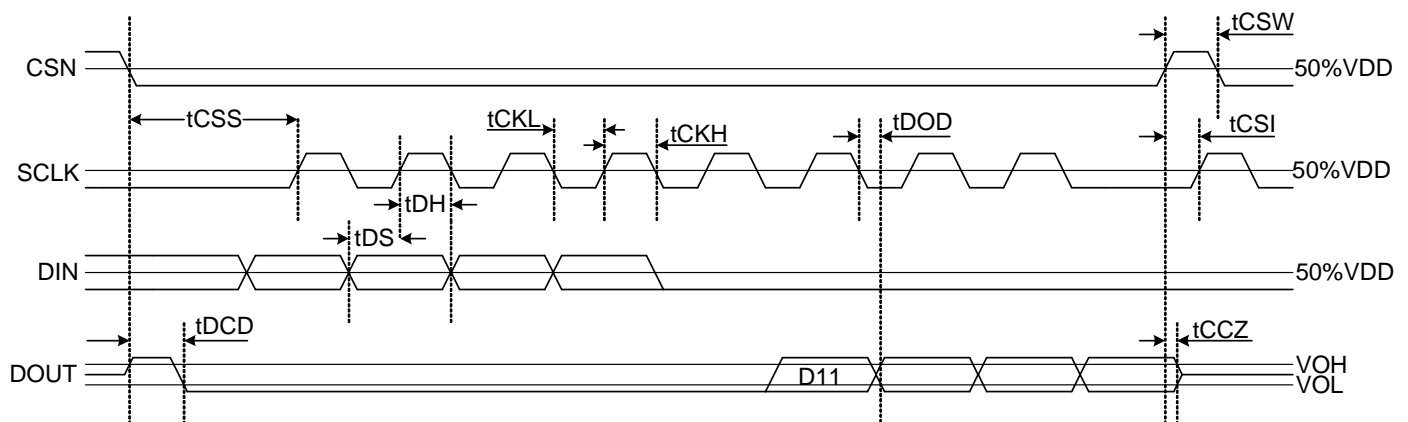
The SX8653 is designed for 4-wire and 5-wire resistive touch screen applications. The touch screen or touch panel is the resistive sensor and can be activated by either a finger or stylus. When the top layer is pressed, it makes contact with the bottom sheet and the touch location can be measured.

As shown in Figure 5 with a 4-wire panel, the touch screen coordinates and touch pressure are converted into SPI format by the SX8653 for transfer to the host.

The auxiliary input can be used to convert with 12-bit resolution any analog input in the supply range. It can also serve as an external synchronisation input to trig the touchscreen acquisition as described in the Application Information section.

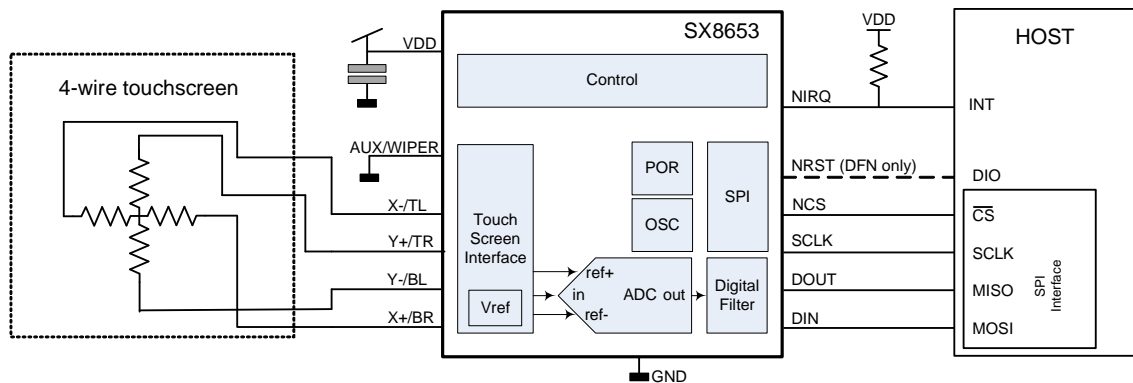

Figure 5. SX8653 with a 4-wire touch screen

A 5-wire touchscreen application is shown in Figure 6. The 5-wire top sheet acts as a voltage measuring probe. The measurement accuracy is not affected by damage on this sheet and consequently the reliability is improved.

Multitouch and touch pressure measurement are not possible with 5-wire touchscreen.

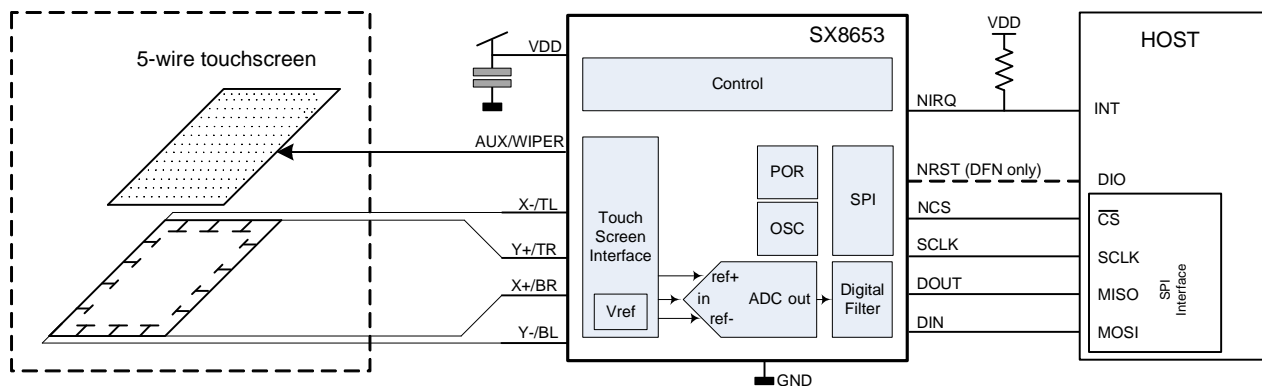

Figure 6. SX8653 with a 5-wire touch screen

3.2. Device Interface and ESD protection

The touch screen controller inputs have been specially designed to provide robust on-chip ESD protection of up to $\pm 15\text{kV}$ in both HBM and Contact Discharge.

3.2.1. Touchscreen interface

The X+/BR, X-/TL, Y+/TR, Y-/BL, AUX/WIPER are the pins dedicated for the touchscreen interface. It provides the voltage sequence in order to obtain the coordinates and pressure measurement.

The five pins are connected to BR, TL, TR, BL, WIPER on a 5-wire touchscreen. They are the electrodes on the 4 corners of the bottom layer of the touchscreen plus the electrode on the top layer.

On a 4-wire touchscreen, only 4 electrodes are used: X+, X-, Y+, Y-. The AUX pin is not needed and therefore can be used to convert an analog signal (range GND - VDD) into 12-bit digital value. The touchscreen interface pins are the most exposed pins for an ESD event.

As shown in Figure 7, these pins have internal ESD protection to GROUND and VDD.

3.2.2. Host Interface and Control Pins

The SX8653 is a slave device configured via the SPI interface. DIN and SCLK have internal ESD protection to GROUND and VDD.

NIRQ provides an interrupt to the host processor when a pen is detected or when channel data is available. The NIRQ pin is an active low, open drain output to facilitate interfacing to different supply voltages and thus requires an external pull-up resistor (1-10 kOhm).

The host can reset the chip via the SPI interface or with the dedicated pin NRST. The NRST pin is an active low input with an internal pull-up that provides a hardware reset.

NRST and NIRQ pins are protected to GROUND.

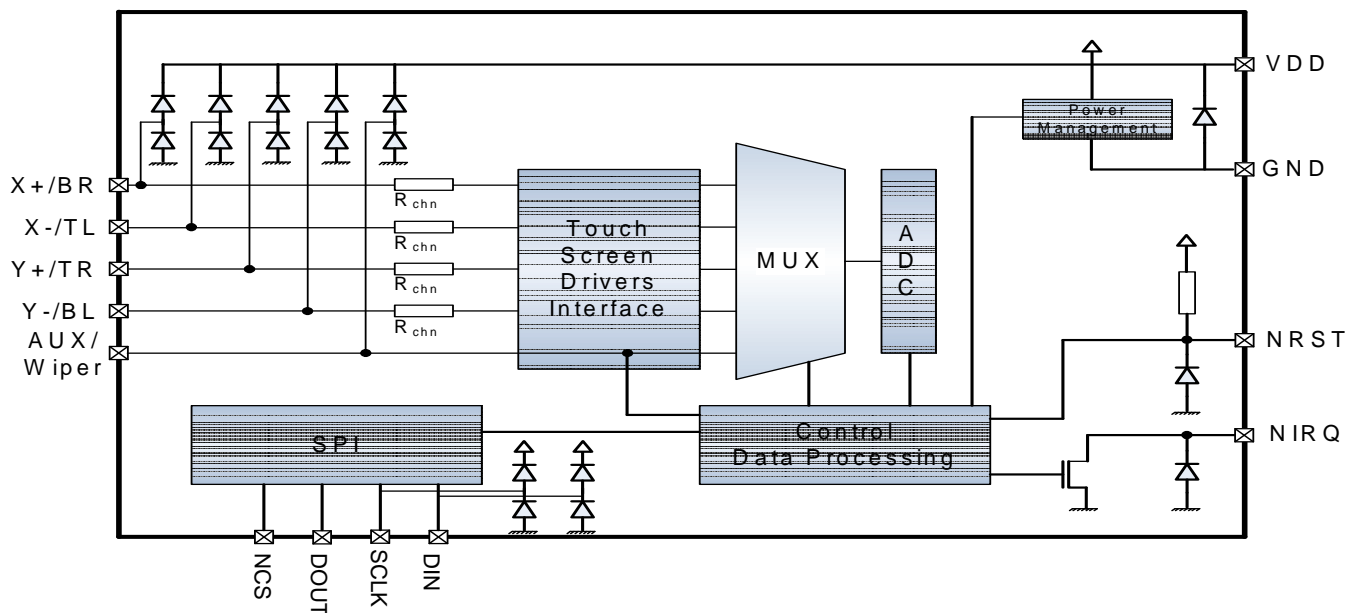

Figure 7. ESD protection

4. 4-wire Touch Screen Detailed Description

4.1. Touch Screen Operation

A 4-wire resistive touch screen consists of two resistive sheets separated by an insulator (Figure 4.2).

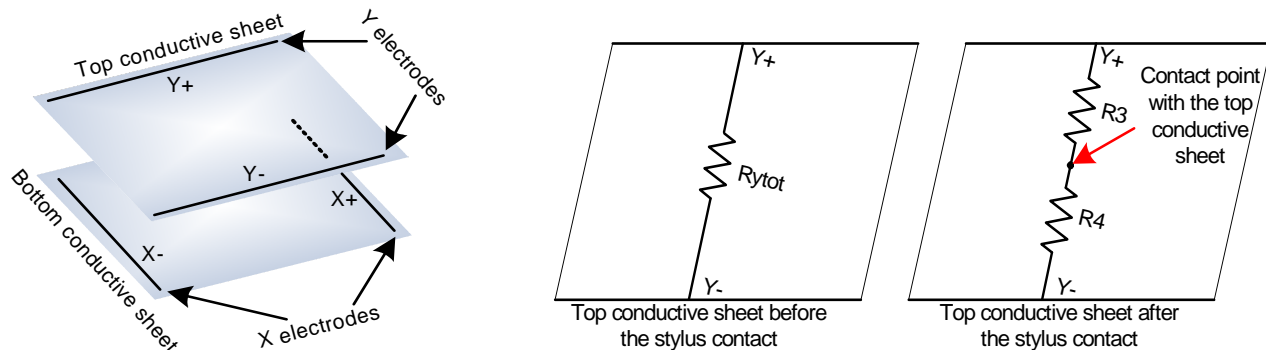

Figure 8. 4-wire Touch Screen

When a pressure is applied on the top sheet with a stylus for example, a connection with the lower sheet is made.

The contact point split the R_{xtot} bottom resistance in the vertical axis into two resistances $R1$ and $R2$. In the same way, the R_{ytot} resistance in the horizontal axis of the top sheet is divided into two resistances $R3$ and $R4$.

$$R_{xtot} = R1 + R2$$

$$R_{ytot} = R3 + R4$$

The touchscreen controller imposes a voltage level on X or Y electrodes allowing the detection of the contact position.

4.2. Coordinates Measurement

During the touch, the top and bottom touchscreen layers are connected. The resistance between the two sheets is R_T . A current coming from the reference voltage goes from $X+$ to $X-$ to perform the X coordinate measurement. Figure 9 shows the measurement schematics.

Since the ADC had a high input impedance, no current flows through R_T and $R3$. The positive ADC input is biased with a voltage created by the $R1$, $R2$ voltage divider.

The conversion with the 12 bit ADC gives the X location.

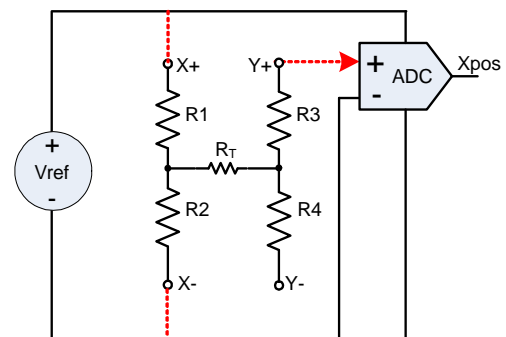

Figure 9. Abscissa (X) coordinates measurement

$$X_{pos} = 4095 \cdot \frac{R2}{R1 + R2}$$

The Y coordinate is measured in a similar fashion with the measurement setup given in Table 7.

$$Y_{pos} = 4095 \cdot \frac{R4}{R3 + R4}$$

4.3. Pressure Measurement

The 4-wire touchscreen allows pressure measurement. The contact resistance between the two sheets are a function of the pressure applied on the top sheet. Indeed, the a low pressure applied with the finger will create a small contact area. With a greater pressure, the contact area will be bigger and the R_T resistance smaller.

The R_T contact resistance is therefore an indication of the applied pressure. R_T is deducted from Z1 and Z2 measurement. The measurement setup given in Table 7 allows to find Z1 and Z2.

$$z1 = 4095 \cdot \frac{R4}{R1 + R4 + R_T} \quad z2 = 4095 \cdot \frac{R4 + R_T}{R1 + R4 + R_T}$$

Arranging Z1 and Z2 with R_{xtot} and R_{ytot} allows the computation of R_T .

$$R_T = R_{ytot} \cdot \frac{Y_{pos}}{4095} \cdot \left[\frac{z2}{z1} - 1 \right]$$

An alternative calculation method is using X_{pos} and Y_{pos} .

$$R_T = \frac{R_{ytot} \cdot Y_{pos}}{4095} \cdot \left[\frac{4095}{z1} - 1 \right] - R_{xtot} \cdot \left[1 - \frac{X_{pos}}{4095} \right]$$

Measurement	Vref +	Vref-	ADC +
X	X+	X-	Y+
Y	Y+	Y-	X+
Z1	X+	Y-	Y+
Z2	X+	Y-	X-

Table 7. Measurement setup

4.4. Pen Detection

The pen detection circuitry is used to detect a user action on the touchscreen. The contact between the two layers generates an interrupt or starts an acquisition sequence.

Doing a pen detection prior to conversion avoids feeding the host with dummy data and saves power.

If the touchscreen is powered between X+ and Y- through a resistor R_{PNDT} , no current will flow so long as pressure is not applied to the surface (see Figure 10).

When a pressure is applied, a current path is created and brings X+ to the level defined by the resistive divider determined by R_{PNDT} and the sum of $R1$, R_T and $R4$.

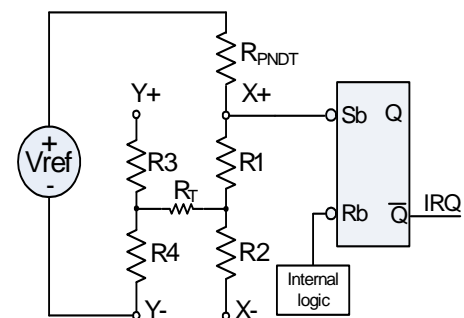

Figure 10. 4-wire pen detection circuitry

R_{PNDT} should be set to the greatest value of 200 kOhm for optimal detection (see Table 16). Increasing PowDly settings can also improve the detection on panel with high resistance.

The pen detection will set the PENIRQ bit of the RegStat register. The PENIRQ bit will be cleared and the NIRQ will be de-asserted as soon as the host reads the status register.

In PENDET mode, the pen detection will set NIRQ low.

4.5. Double touch measurement

The simplified model for double touch on the touchscreen is given in Figure 11.

Two fingers on the touchscreen create two contacts between the touchscreen top and bottom layer. The two contacts have the resistance R_{t1} and R_{t2} .

The two contact points split R_{xtot} and R_{ytot} on the horizontal and vertical axis. Then we have $R1$, $R2$ and $R3$ on the top plate and $R4$, $R5$ and $R6$ on the bottom plate.

$$R_{xtot} = R1 + R2 + R3$$

$$R_{ytot} = R4 + R5 + R6$$

The determination of these resistances is a complex task.

The SX8653 allows to measure R_x and R_y which is a combination of these resistances. With a S/W running in the host, it is possible to detect the gesture described in the section Multi-Touch Gestures with 4-wire touchscreen.

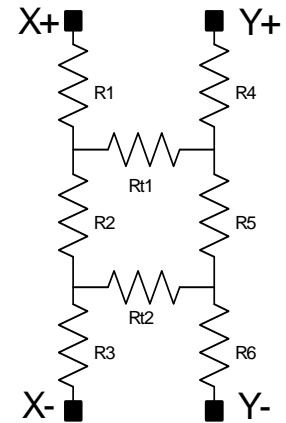

Figure 11. Touchscreen model for double touch

To get the best gesture detection, the resistor R_{mSelX} and R_{mSelY} should be set according to the panel resistance and the Table 8.

Y Panel resistance (Ohm)	R_{mSelY}	X Panel resistance (Ohm)	R_{mSelX}
100 to 187	000	100 to 187	000
188 to 312	001	188 to 312	001
313 to 938	010	313 to 938	010
939 to 1875	011	939 to 1875	011
1876 to 4375	100	1876 to 4375	100
4376 to 9375	101	4376 to 9375	101
9376 to 18780	110	9376 to 18780	110
Larger than 18780	111	Larger than 18780	111

Table 8. R_{mSelX} and R_{mSelY} resistance selection

5. 5-wire Touch Screen Detailed Description

5.1. Touch Screen Operation

As the 4-wire, the 5-wire resistive touch screen consists of two resistive sheets separated by an insulator (Figure 12). The main difference is that the 4 wires are connected on the 4 corners of the bottom conductive sheet. They are referred as Top Left, Top Right, Bottom Left, Bottom Right.

The fifth wire is embedded in the top sheet and is used for sensing the electrode voltage and is referred as the wiper.

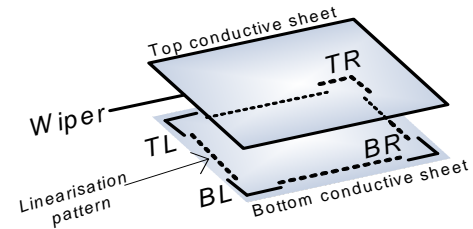

Figure 12. 5-wire touchscreen

5.2. Coordinates Measurement

When the electrodes TL is connected with BL and TR with BR, they form with the linearization pattern 2 electrodes bars which are very similar to the X electrodes in a 4-wire touchscreen. In the same way, the association of TL with TR and BL with BR create Y electrodes.

The four corners are therefore able to produce voltage gradients in the horizontal and vertical axis. The wiper is connected to the high input impedance of the ADC. When a pressure is applied on the top sheet, the contact point split the bottom sheet resistance into R1 and R2 on the X axis and R3 and R4 on the Y axis.

The X and Y position converted by the 12-bit ADC gives the following result.

$$X_{pos} = 4095 \cdot \frac{R2}{R1 + R2} \quad Y_{pos} = 4095 \cdot \frac{R4}{R3 + R4}$$

5.3. Pen Detection

The BR pin is connected to the positive pin of the reference voltage through R_{PNDT}. The wiper panel is grounded at the AUX/WIPER pin to provide the grounding path for a screen touch event.

The BR pin is monitored to detect voltage drop. When a pressure is applied on the top surface, a current path is created between the two layers and the PENIRQ bit of the RegStat register will be set. R_{PNDT} should be set to the greatest value of 200 kOhm for optimal detection (see Table 16). Increasing PowDly settings can also improve the detection on panel with high resistance.

In PENDET mode, the pen detection will set NIRQ low.

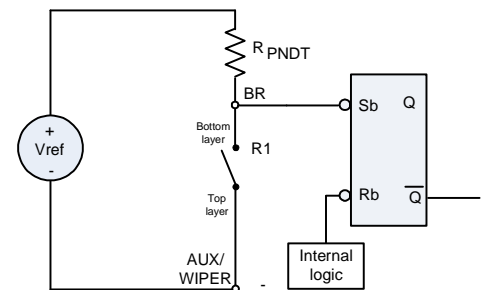

Figure 13. 5-wire pen detection circuitry

6. Data Processing

The SX8653 offers 4 types of data processing which allows the user to make trade-offs between data throughput, power consumption and noise rejection. The parameter FILT is used to select the filter order N_{filt} as seen in Table 9.

The s_n samples from the ADC can be averaged. The processed c_n 12-bit value is then send through the SPI bus.

The noise rejection will be improved with a high order to the detriment of the power consumption.

The K coefficient in Table 9 is a filter constant. Its value is $K=4079/4095$.

FILT	N_{filt}	Explanation	Processing
0	1	No average	$s_n = c_n$
1	3	3 ADC samples are averaged	$s_n = \frac{1}{3}K(c_n + c_{n-1} + c_{n-2})$
2	5	5 ADC samples are averaged	$s_n = \frac{1}{5}K(c_n + c_{n-1} + c_{n-2} + c_{n-3} + c_{n-4})$
3	7	7 ADC samples are sorted and the 3 center samples are averaged	$c_{\text{max}1} \geq c_{\text{max}2} \geq c_a \geq c_b \geq c_c \geq c_{\text{min}1} \geq c_{\text{min}2}$ $s_n = \frac{1}{3}K(c_a + c_b + c_c)$

Table 9. Filter order

7. Power-Up, Reset

During power-up, NIRQ pin is kept low, the POR reset all registers and states of the SX8653. The SX8653 is not accessible and SPI communications are ignored.

As soon as NIRQ rises, the SX8653 is in manual mode with only the SPI peripheral enabled to minimize power consumption.

The host can reset the SX8653 by setting the NRST pin low or via the SPI bus. Writing the code 0xDE to the register RegSoftReset reset the circuit.

When NRST is driven LOW by the host, NIRQ will be driven low by the SX8653. After the reset NIRQ will be released by the SX8653.

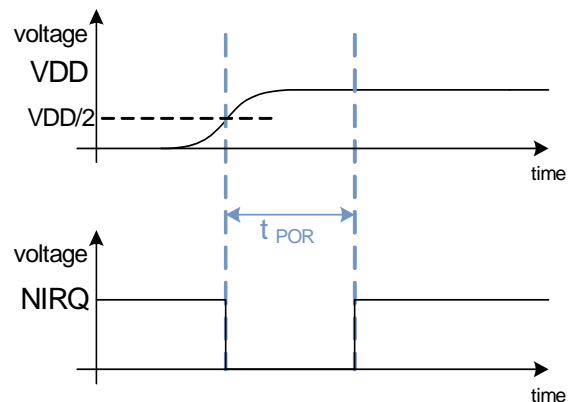

Figure 14. Power-up, NIRQ

8. Modes of Operation

The SX8653 has four operation modes that are configured using the SPI commands as defined in Table 14 and Table 16. These 4 modes are:

- ◆ manual (command 'MANAUTO' and RATE=0),
- ◆ automatic (command 'MANAUTO' and RATE>0),
- ◆ pen detect (command 'PENDET'),
- ◆ pen trigger mode (command 'PENTRG').

In the PENDET mode the pen detection is activated. The SX8653 will generate an interrupt (NIRQ) upon pen detection and set the PENIRQ bit in the SPI status register. To quit the PENDET mode the host needs to configure the manual mode.

In the PENTRG mode the pen detection is activated and a channel conversion will start after the detection of a pen. The SX8653 will generate an interrupt (NIRQ) upon pen detection and set the CONVIRQ bit in the SPI status register. To quit the PENTRG mode the host needs to configure the manual mode. The PENTRG mode offers the best compromise between power consumption and coordinate throughput.

8.1. MANual Mode

In manual mode (RATE=0), the host sequences all the actions by the SPI commands described in Table 10.

When a command is received, the SX8653 executes the associated task and waits for the next command.

Command	Action
CONVERT(CHAN)	Select and bias a channel Wait for the programmed settling time (POWDLY) Start conversion
SELECT(CHAN)	Select and bias a channel

Table 10. CONVERT and SELECT command

The channel can be biased for an arbitrary amount of time by first sending a SELECT command and then a CONVERT command once the settling time requirement is met.

The SELECT command can be omitted if the large range of POWDLY settings cover the requirements. In the latter case, the CONVERT command alone is enough to perform an acquisition.

With CHAN=SEQ, multiple channels are sampled. This requires programming the POWDLY field in register RegCTRL0. The selected channel will be powered during POWDLY before a conversion is started. The channel bias is automatically removed after the conversion has completed.

8.2. AUTOMATIC mode

In automatic mode (RATE > 0), SX8653 start the acquisition when a touch is detected. It converts all the channels selected with RegChnMsk and set NIRQ low when it is finished.

After the host has read the channels, if CONDIRQ=1 and the touch is detected again, the SX8653 starts a new conversion cycle.

To not loose data, the SX8653 does not begin conversion before the host read all the channels.

We can define the time t_s between the start of the conversion and the end of the channels reading by the host.

The rate programmed is achieved if $t_s < 1/\text{RATE}$ otherwise the new rate is $1/t_s$.

When the control CONDIRQ bit (see register RegStat Table 16) is set to '1' then the interrupts will only be generated if the pen detect occurred. This result in a regular interrupt stream, as long as the host performs the read channel commands, and the screen is touched. When the screen is not touched, interrupts does not occur.

If the control CONDIRQ bit is cleared to '0', the interrupts will be always generated. In case there is no pen detected on the screen then the coordinate data will be qualified as invalid, see section [9.5]. This result in a regular interrupt stream as long as the host performs the read channel commands,

This working is illustrated in Figure 17.

Figure 15 shows the SPI working in automatic mode with CONDIRQ=1. After the first sentence send through the SPI to make the initialization, traffic is reduced as only reads are required.

The processing time is the necessary time for the SX8653 to make the pen detection, the settling time (POWDLY) and the conversion of the selected channels. This time increases with the number of channel selected and the filter used. NIRQ interrupt signal notifies the host when the conversions are done.

The host just need to read the channels data to release the interrupt.

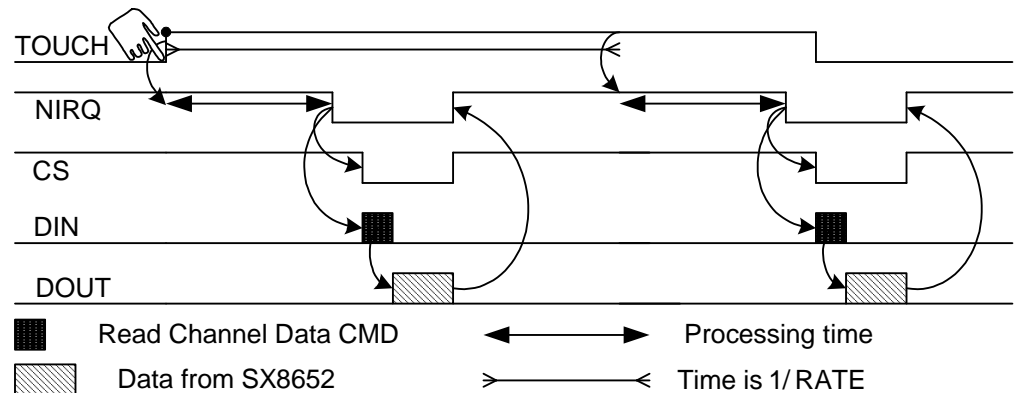

Figure 15. SPI working in AUTO mode

8.3. PENDET Mode

The PENDET mode can be used if the host only needs to know if the screen has been touched or not and take from that information further actions. When pen detect circuitry is triggered the interrupt signal NIRQ will be generated and the status register bit 'PENIRQ' will be set. The bit is cleared by reading the status register RegStat. The PENDET working is illustrated in Figure 17.

8.4. PENTRIG Mode

The PENTRIG mode offers the best compromise between power consumption and coordinate throughput.

In this mode the SX8653 will wait until a pen is detected on the screen and then starts the coordinate conversions. The host will be signaled only when the screen is touched and coordinates are available. The flowchart describes in Figure 17.

The coordinate rate in pen trigger mode is determined by the speed of the host reading the channels and the conversion times of the channels. The host performs the minimum number of SPI commands in this mode.

The host has to wait for the NIRQ interrupt to make the acquisition of the data.

The SPI working is illustrated in Figure 16.

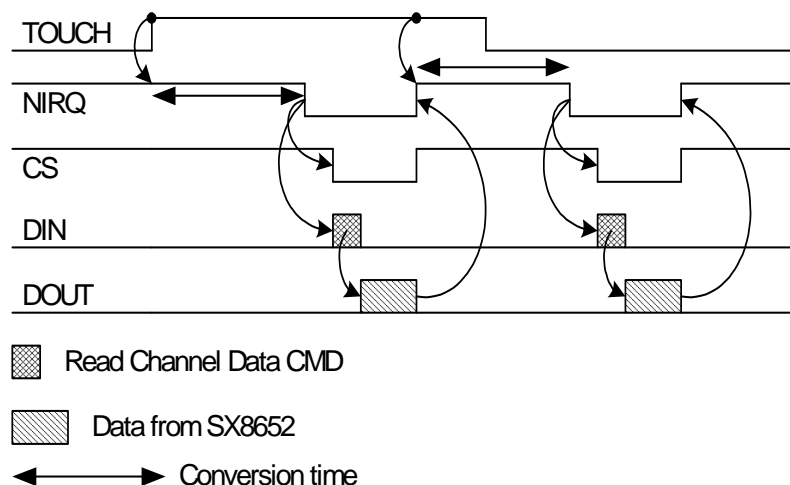

Figure 16. SPI working in PENTRIG mode

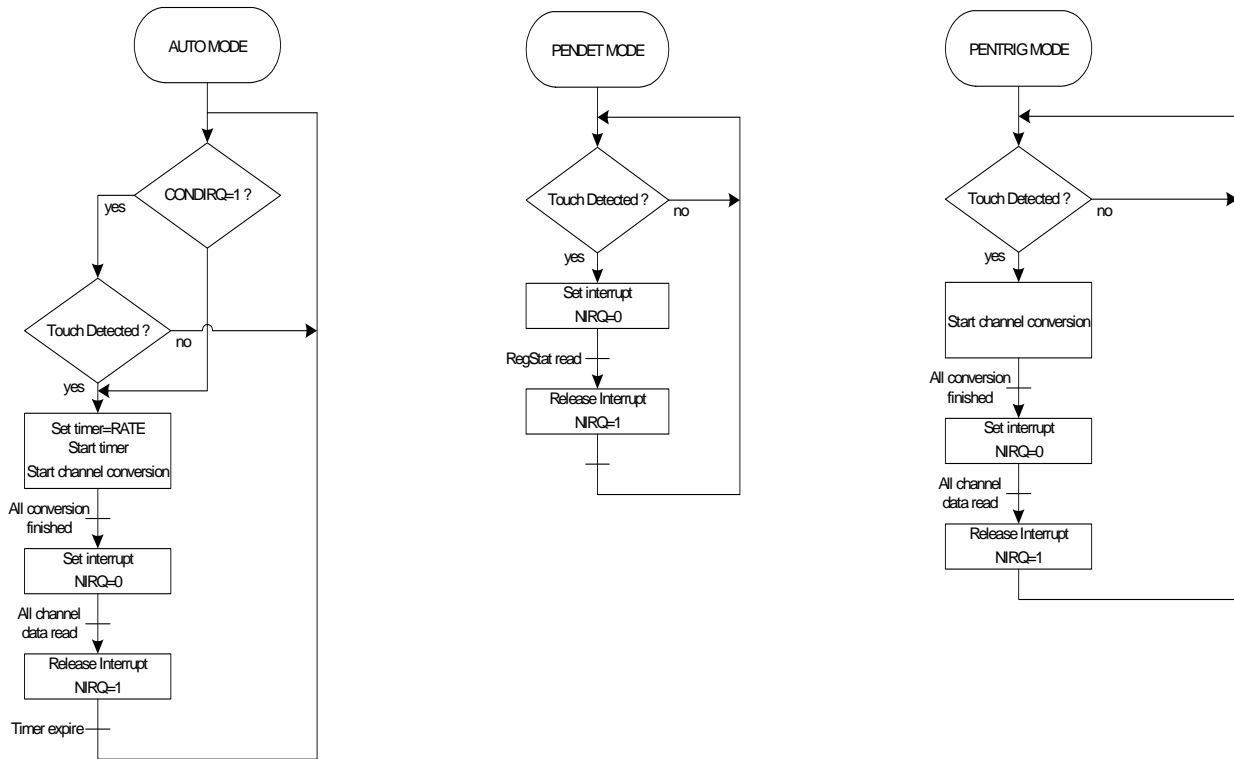

Figure 17. AUTO, PENDET and PENTRIG Mode Flowchart

9. Host Interface

The host interfaced is composed of a SPI bus. It performs the read/ write operations on the registers and channels data.

9.1. SPI Read/Write Registers

The WRITE command allows the host to write a single or multiple registers in the SX8653. The host can read single or multiple registers from the SX8653 by the READ command. This is defined in Table 11.

W/R command name	CR(7:0)								Function
	7	6	5	4	3	2	1	0	
WRITE(RA)	0	0	0	RA(4:0)					Write register (see Table 15 for RA)
READ(RA)	0	1	0	RA(4:0)					Read register (see Table 15 for RA)

Table 11. W/R commands

9.2. SPI Reading Channel Data

Five channels can be sampled by the SX8653: X, Y, Z1, Z2 and AUX. They are defined in Table 13. They can be converted in sequence with the RegChanMsk register.

The READCHAN command allows the host to read the data obtained after the channels conversion and processing.

W/R command name	CR(7:0)								Function
	7	6	5	4	3	2	1	0	
READCHAN	0	0	1	x	x	x	x	x	Read data from channel

Table 12. Read Channels Data

Channel	CHAN(2:0)			Function
	2	1	0	
X	0	0	0	X channel
Y	0	0	1	Y channel
Z1	0	1	0	First channel for pressure measurement
Z2	0	1	1	Second channel for pressure measurement
AUX	1	0	0	Auxiliary channel
RX	1	0	1	Double touch RX measurement
RY	1	1	0	Double touch RY measurement
SEQ	1	1	1	Channel sequentially selected from RegChanMsk register, (see Table 16)

Table 13. Channel definition

The channel data are 12-bit of unsigned format which corresponds to integers between 0 and 4095. This is send on two bytes, MSB first then LSB. A mask with the value 0x0FFF (4095) must be done to filter the four first unknown bit.

When a channel data has been transmitted, the next one is sent in the successive order: X, Y, Z1, Z2 and AUX. If a channel has not been converted, the data is not transmitted.

When the channel data buffer gets empty, the data will carry an invalid data as explained in the channel data format.

Remark: After a conversion sequence, it is possible to read only one time the same channel.

Example: the SX8653 is set to convert X and Y. The value 0xC0 is set in RegChanMsk. The first byte read after the READCHAN command will be X(MSB), then X(LSB), Y(MSB) and at the end Y(LSB). If the host carry on the reading, it will get invalid data.

9.3. SPI Host Commands

The host can issue commands to change the operation mode or perform manual actions as defined in Table 14.

command name	CR(7:0)								Function
	7	6	5	4	3	2	1	0	
SELECT(CHAN)	1	0	0	0	x	CHAN(2:0)			Bias channel (see Table 13 for CHAN)
CONVERT(CHAN)	1	0	0	1	x	CHAN(2:0)			Bias channel (see Table 13 for CHAN)
MANAUTO	1	0	1	1	x	x	x	x	Enter manual or automatic mode.
PENDET	1	1	0	0	x	x	x	x	Enter pen detect mode.
PENTRG	1	1	1	0	x	x	x	x	Enter pen trigger mode.

Table 14. Host Commands

9.4. SPI implementation and multiple Read/Write

The SPI implemented on the SX8653 is set to the common setting CPOL=0 and CPHA=0 which means data are sampled on the rising edge of the clock, and shifted on the falling one.

The default state of the clock when NCS gets asserted is low. If a host send a command while the system is busy, the command is discarded.

The SPI protocol is designed to be able to do multiple read/write during a transaction. During one single operation, as long as NCS stay asserted, the register address is automatically increased to allow sequential read/write (or sequential retrieval of data). Between each different operation though (READ/WRITE/READCHAN), the communication should be restarted.

This is described in Figure 18.

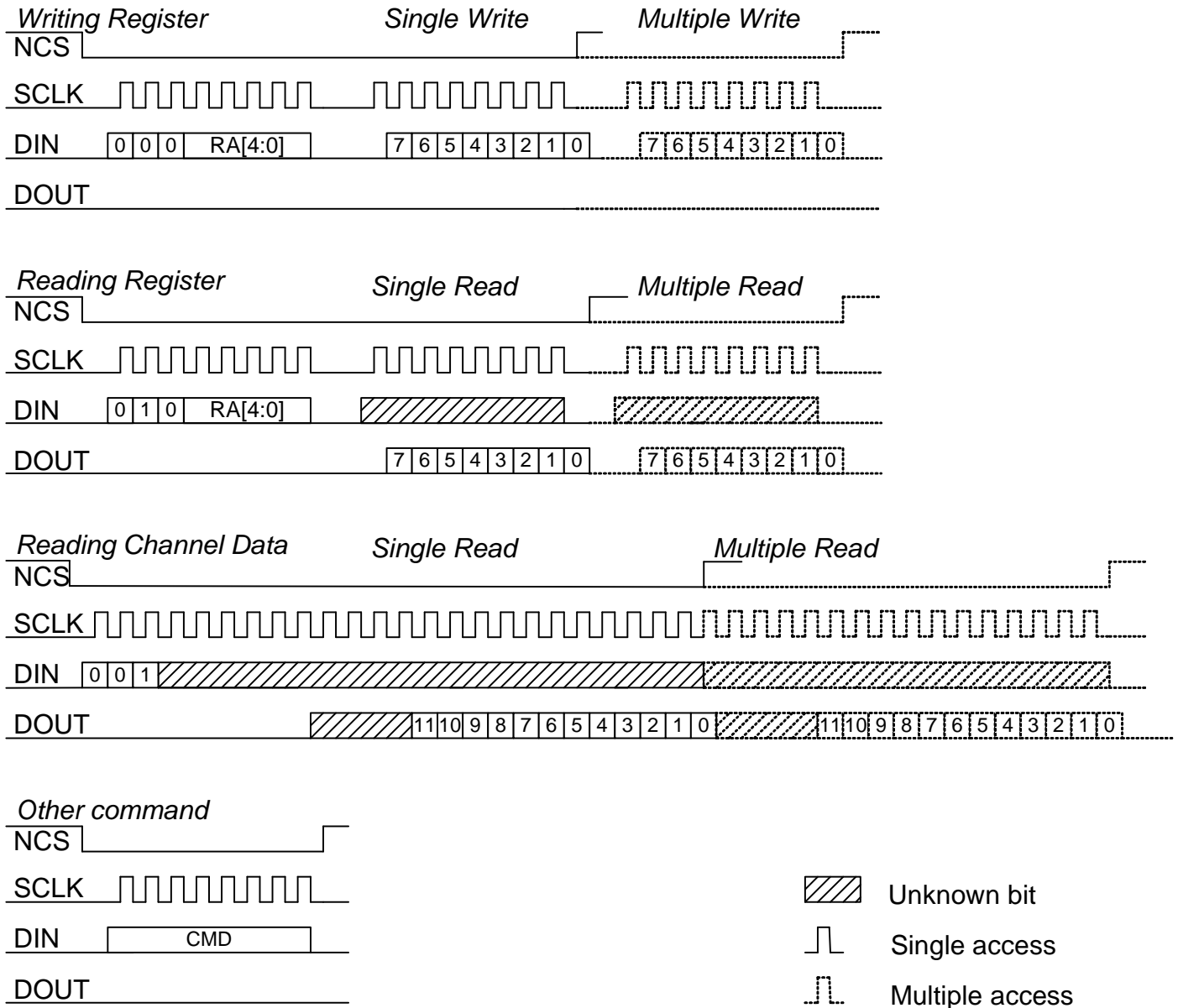

Figure 18. Data channel format

9.5. Invalid Qualified Data

The SX8653 returns 0xFFFF data in case of invalid qualified data.

This occurs:

- ◆ When the SX8653 has read all the channel data in the FIFO
- ◆ When a conversion is done without a pen being detected.

9.6. Register Map

Register Address RA(4:0)	Register	Description
0 0000	RegCtrl0	Write, Read
0 0001	RegCtrl1	Write, Read
0 0010	RegCtrl2	Write, Read
0 0011	RegCtrl3	Write, Read
0 0100	RegChanMsk	Write, Read
0 0101	RegStat	Read
1 1111	RegSoftReset	Write

Table 15. Register address

The details of the registers are described in the next sections.

9.7. SX8653 register

Register	Bit	Default	Description		
RegCtrl0	7:4	0000	RATE	Set rate in coordinates per sec (cps) ($\pm 20\%$) If RATE =0: Manual mode. if RATE >0: Automatic mode 0000: Timer disabled -Manual mode 0001: 10 cps 0010: 20 cps 0011: 40 cps 0100: 60 cps 0101: 80 cps 0110: 100 cps 0111: 200 cps	1000: 300 cps 1001: 400 cps 1010: 500 cps 1011: 1k cps 1100: 2k cps 1101: 3k cps 1110: 4k cps 1111: 5k cps
				3:0	0000
RegCtrl1	7:6	00	AUXAQC		
				The AUX trigger works only in manual mode with 4-wire touchscreen	
	5	1	CONDIRQ	Enable conditional interrupts 0: interrupt always generated at end of conversion cycle. If no pen is detected the data is set to 'invalid qualified'.	1: interrupt generated when pen detect is successful
	4	0	SCREEN	Select the type of screen: 0: 4-wire	1: 5-wire
	3:2	00	RPDNT	Select the Pen Detect Resistor 00: 100 kOhm 01: 200 kOhm	10: 50 kOhm 11: 25 kOhm
RegCtrl2	1:0	00	FILT	Digital filter control 00: Disable 01: 3 sample averaging	10: 5 sample averaging 11: 7 sample acquisition, sort, average 3 middle samples
	7:4	0	don't care		
RegCtrl2	3:0	0000	SETDLY	Settling time while filtering ($\pm 10\%$) 0000: Immediate (0.5 us) 0001: 1.1 us 0010: 2.2 us 0011: 4.4 us 0100: 8.9 us 0101: 17.8 us 0110: 35.5 us 0111: 71.0 us	1000: 0.14 ms 1001: 0.28 ms 1010: 0.57 ms 1011: 1.14 ms 1100: 2.27 ms 1101: 4.55 ms 1110: 9.09 ms 1111: 18.19 ms

Table 16. SX8653 Register

Register	Bit	Default	Description		
RegCtrl3	7:6	0	don't care		
	5:3	RmSelY	Check Table 8		
	2:0	RmSelX	Check Table 8		
RegChanMsk	7	1	XCONV	0: no sample	1: Sample X channel
	6	1	YCONV	0: no sample	1: Sample Y channel
	5	0	Z1CONV	0: no sample	1: Sample Z1 channel
	4	0	Z2CONV	0: no sample	1: Sample Z2 channel
	3	0	AUXCONV	0: no sample	1: Sample AUX channel
	0	0	RXCONV	0: no sample	1: Sample RX channel
	0	0	RYCONV	0: no sample	1: Sample RY channel
	0	0	don't care		
RegStat	Host writing to this register is ignored.				
	7	0	CONVIRQ	0: no IRQ pending 1: Conversion sequence finished IRQ is cleared by the channel data read command	
	6	0	PENIRQ	Operational in pen detect mode 0: no IRQ pending 1: Pen detected IRQ pending IRQ is cleared by the RegStat reading	
	5	1	RSTEVENT	A reset event has occurred	
	4:0	00000	don't care		
RegSoftReset	7:0	0x00	Writing 0xDE to this register reset the SX8653 Any other data will not affect the SX8653		

Table 16. SX8653 Register

10. Application Information

This section describes in more detail application oriented data.

10.1. Acquisition Setup

Prior to an acquisition, the SX8653 can be setup by writing the control registers. Registers are written by issuing the register write command. They can be read by issuing the read command. Please refer to the section [9.7].

10.2. Channel Selection

The SX8653 can be setup to start a single channel conversion or to convert several channels in sequence. For a single conversion, the channel to be converted is determined from the CHAN(2:0) field in the command word (defined in Table 13).

Several channels defined in RegChanMsk can be acquired sequentially by setting the CHAN(2:0) field to SEQ. The channels will be sampled in the order X, Y, Z1, Z2, AUX.

10.3. Noise Reduction

A noisy environment can decrease the performance of the controller. For example, an LCD display located just under the touch screen can add a lot of noise on the high impedance A/D converter inputs.

10.3.1. POWDLY

In order to perform correct coordinates acquisition properly, some time must be given for the touch screen to reach a proper level. It is a function of the PCB trace resistance connecting the SX8653 to the touchscreen and also the capacitance of the touchscreen. We can define tau as the RC time constant. POWDLY duration should be programmed to 10 tau to reach 12 bit accuracy.

Adding a capacitor from the touch screen drivers to ground is a solution to minimize external noise but it increases settling time and consequently the power consumption.

10.3.2. SETDLY

A best method to filter noise is described in section [6] (Data processing). When filtering is enabled, the channel will be biased initially during a time of POWDLY for the first conversion. The parameter SETDLY sets the settling time between the subsequent conversions in a filter set. In most applications, SETDLY can be set to 0. In applications with a high tau and where accuracy of 1LSB is required SETDLY should be increased.

10.4. AUX Input - 4-wire touchscreen only

The AUX input can be used to sample an analog signal in the range 0-VDD. For system supply by battery, the battery voltage can be monitored for example. The conversion is done in sequence with the touchscreen acquisition therefore the sample rate is defined with RegCtrl0 in AUTO mode.

The AUX pin can also triggered conversions. A rising edge, a falling edge or both applied on the AUX pin can trigger the conversion. This is defined by AUXACQ in RegCtrl1.

This method can be used to sample touchscreen when there is noise-free periods.

10.5. Interrupt Generation

An interrupt (NIRQ=0) will be generated:

- ◆ During the power-up phase or after a reset
- ◆ After completion of a conversion in MANUAL, PENTRIG or AUTO mode. CONVIRQ (bit [7] of RegStat) will be set at the same time.
- ◆ After a touch on the panel being detected in PENDET mode. PENIRQ (bit [6] of RegStat) will be set at the same time.

The NIRQ will be released and pulled high(NIRQ=1) by the external pull-up resistor:

- ◆ When the power-up phase is finished
- ◆ When the host read all channels data that were previously converted by the SX8653 in MANUAL, PENTRIG or AUTO mode. CONVIRQ will be cleared at the same time.
- ◆ When the host read the status register in PENDET mode. PENIRQ, will be cleared at the same time.

An active NIRQ (low) needs to be cleared before any new conversions will occur.

10.6. Coordinate Throughput Rate

The coordinate throughput rate depends on the following factors:

- ◆ The SPI communication time: T_{com}
- ◆ The conversion time: T_{conv}

The coordinate rate is the frequency to get the X, Y, Z1 and Z2 coordinate: $CoordRate = \frac{1}{T_{com} + T_{conv}}$

10.6.1. SPI Communication Time

The minimum time to read the channel data in PENTRIG mode is: $T_{com} = (8 + 16 \times N_{chan}) \times T_{SPI}$

The highest throughput will be obtained with a SPI frequency of 5MHz when the host read the channel data as quickly as possible after the NIRQ falling edge.

10.6.2. Conversion Time

The maximum possible throughput can be estimated with the following equation

$$T_{conv} = 47 \cdot T_{osc} + N_{chan} [POWDLY + SETDLY(N_{filt} - 1) + T_{osc}(21N_{filt} + 1)]$$

with:

- ◆ $N_{filt} = \{1,3,5,7\}$ based on the order defined for the filter FILT (see Figure 9).
- ◆ $N_{chan} = \{1,2,3,4,5,6,7\}$ based on the number of channels defined in RegChanMsk
- ◆ POWDLY = 0.5us to 18.19ms, settling time as defined in RegCtrl0
- ◆ SETDLY = 0.5us to 18.19ms, settling time when filtering as defined in RegCtrl2
- ◆ T_{osc} is the oscillator period (555ns +/- 15%)

Table 17 gives some examples of Coordinate Rate and Sample Rate for various setting in PENTRIG mode.

Nch [1..5]	Nfilt [1 3 5 7]	PowDly [uS]	SetDly [uS]	Tconv [uS]	Tcomm [uS]	CoordRate [kSPS]
2	1	0.5	-	51	8	16.7
2	3	71	0.5	190	8	5.0
4	3	140	0.5	740	14	1.3

Table 17. Coordinate throughput examples

10.7. ESD event

In case of ESD event, the chip may reset to protect its internal circuitry. The bit *RSTEVENT* indicates that a reset event has occurs. ESD event may trig the pen detection circuitry. In this case wrong data will be send to the host. To detect this false coordinates on 4-wire touchscreen, Z1 and Z2 can be read. The conditions $Z1 < \text{LowThreshold}$ and $Z2 > \text{HighThreshold}$ may indicate an ESD event. The values LowThreshold and HighThreshold are given for indication only on the table below and should be fine tune according to the system.

LowThreshold	HighThreshold
10	4070

Table 18. Threshold to detect false coordinates

11. Multi-Touch Gestures with 4-wire touchscreen

11.1. Zoom Gesture

A simple thumb and forefinger “pinch” movement that enables a user to enlarge objects onscreen (moving fingers away from each other) or make them smaller (move them towards each other). This intuitive zooming function replaces the standard point-and-click functionality of a mouse and provides far greater accuracy to the user.



Figure 19. Zoom gesture

11.2. Rotate Gesture

Rotate objects onscreen by making simple clockwise (right) or counterclockwise (left) movements with the anchored thumb and forefinger. This multi-touch function enables swift and accurate positioning of objects without needing to point and click repeatedly on a rotate left-right function button in order to achieve the desired effect.



Figure 20. Rotate gesture

12. Packaging Information

12.1. DFN Package

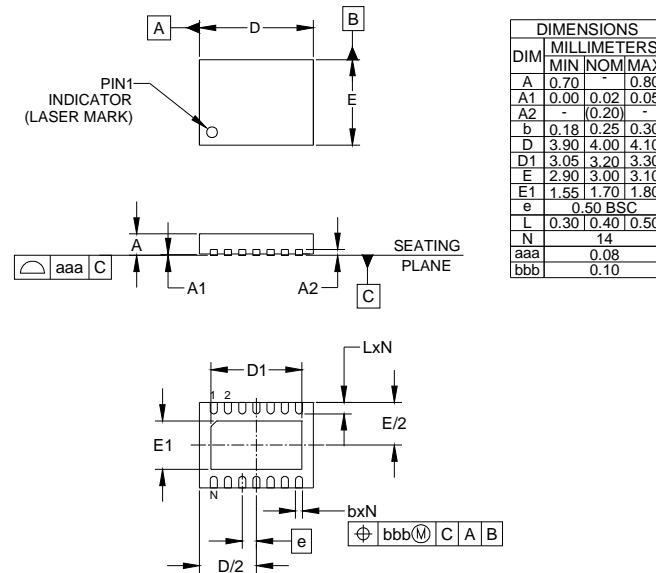

NOTES:

1. CONTROLLING DIMENSIONS ARE IN MILLIMETERS (ANGLES IN DEGREES).
2. COPLANARITY APPLIES TO THE EXPOSED PAD AS WELL AS THE TERMINALS.

Figure 21. DFN Package Outline Drawing

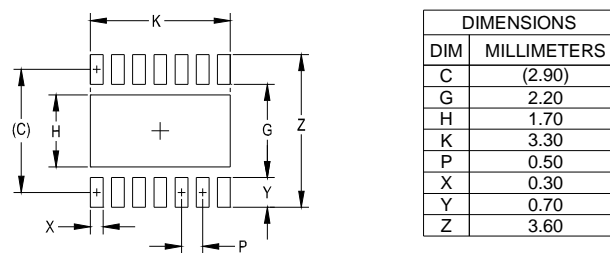

NOTES:

1. CONTROLLING DIMENSIONS ARE IN MILLIMETERS (ANGLES IN DEGREES).
2. THIS LAND PATTERN IS FOR REFERENCE PURPOSES ONLY. CONSULT YOUR MANUFACTURING GROUP TO ENSURE YOUR COMPANY'S MANUFACTURING GUIDELINES ARE MET.
3. THERMAL VIAS IN THE LAND PATTERN OF THE EXPOSED PAD SHALL BE CONNECTED TO A SYSTEM GROUND PLANE. FAILURE TO DO SO MAY COMPROMISE THE THERMAL AND/OR FUNCTIONAL PERFORMANCE OF THE DEVICE.

Figure 22. DFN Package Land Pattern

12.2. WLCSP Package

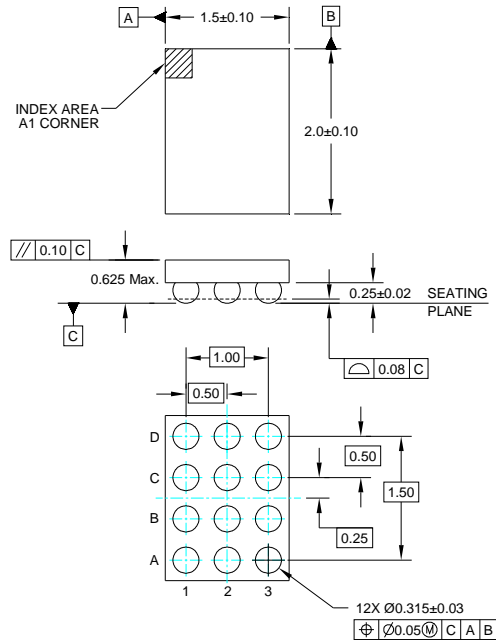

NOTES:
1. CONTROLLING DIMENSIONS ARE IN MILLIMETERS

Figure 23. WLCSP Package Outline Drawing

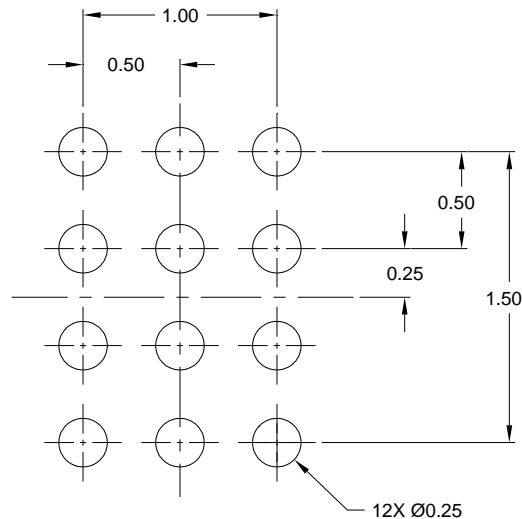

NOTES:
1. CONTROLLING DIMENSIONS ARE IN MILLIMETERS
2. THIS LAND PATTERN IS FOR REFERENCE PURPOSES ONLY. CONSULT YOUR MANUFACTURING GROUP TO ENSURE YOUR COMPANY'S MANUFACTURING GUIDELINES ARE MET.

Figure 24. WLCSP Land Pattern of WLCSP

© Semtech 2010

All rights reserved. Reproduction in whole or in part is prohibited without the prior written consent of the copyright owner. The information presented in this document does not form part of any quotation or contract, is believed to be accurate and reliable and may be changed without notice. No liability will be accepted by the publisher for any consequence of its use. Publication thereof does not convey nor imply any license under patent or other industrial or intellectual property rights. Semtech assumes no responsibility or liability whatsoever for any failure or unexpected operation resulting from misuse, neglect improper installation, repair or improper handling or unusual physical or electrical stress including, but not limited to, exposure to parameters beyond the specified maximum ratings or operation outside the specified range.

SEMTECH PRODUCTS ARE NOT DESIGNED, INTENDED, AUTHORIZED OR WARRANTED TO BE SUITABLE FOR USE IN LIFE-SUPPORT APPLICATIONS, DEVICES OR SYSTEMS OR OTHER CRITICAL APPLICATIONS. INCLUSION OF SEMTECH PRODUCTS IN SUCH APPLICATIONS IS UNDERSTOOD TO BE UNDERTAKEN SOLELY AT THE CUSTOMER'S OWN RISK. Should a customer purchase or use Semtech products for any such unauthorized application, the customer shall indemnify and hold Semtech and its officers, employees, subsidiaries, affiliates, and distributors harmless against all claims, costs damages and attorney fees which could arise.

All referenced brands, product names, service names and trademarks are the property of their respective owners.

Contact information

Semtech Corporation Advanced Communications & Sensing Products

E-mail: sales@semtech.com acsupport@semtech.com Internet: <http://www.semtech.com>

USA 200 Flynn Road, Camarillo, CA 93012-8790.
Tel: +1 805 498 2111 Fax: +1 805 498 3804

FAR EAST 12F, No. 89 Sec. 5, Nanking E. Road, Taipei, 105, TWN, R.O.C.
Tel: +886 2 2748 3380 Fax: +886 2 2748 3390

EUROPE Semtech Ltd., Units 2 & 3, Park Court, Premier Way, Abbey Park Industrial Estate, Romsey, Hampshire, SO51 9DN.
Tel: +44 (0)1794 527 600 Fax: +44 (0)1794 527 601