

**ADVANCED COMMUNICATIONS & SENSING****DATASHEET****GENERAL DESCRIPTION**

The SX8661Z is an ultra low power, fully integrated 8-channel solution for capacitive touch-button and proximity detection applications. Unlike many capacitive touch solutions, the SX8661Z features dedicated capacitive sense inputs (that requires no external components) in addition to 8 general purpose I/O ports (GPIO). Each of the 8 on-chip GPIO/LED driver is equipped with independent PWM source for enhanced visual effect such as dimming, and breathing.

The SX8661Z includes a capacitive 10 bit ADC analog interface with automatic compensation up to 100pF. The high resolution capacitive sensing supports a wide variety of touch pad sizes and shapes and allows capacitive buttons to be created using thick overlay materials (up to 5mm) for an extremely robust and ESD immune system design.

The SX8661Z incorporates a versatile firmware that was specially designed to simplify capacitive touch solution design and offers reduced time-to-market. Integrated multi-time programmable memory provides the ultimate flexibility to modify key firmware parameters (gain, threshold, scan period, auto offset compensation) in the field without the need for new firmware development.

The SX8661Z supports the 400 kHz I²C serial bus data protocol and includes a field programmable slave address. The tiny 4mm x 4mm footprint makes it an ideal solution for portable, battery powered applications where power and density are at a premium.

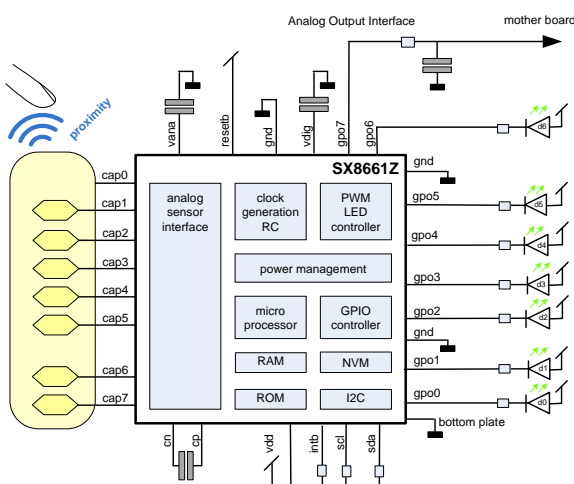
TYPICAL APPLICATION CIRCUIT**KEY PRODUCT FEATURES**

- ◆ Complete 8 Sensors Capacitive Touch-Button Solution
 - Up to 8 LED Drivers for individual Visual Feedback with Auto Lightening
 - Configurable Single or Continuous Fading Mode
 - 256 steps PWM Linear and Logarithmic control
- ◆ Proximity Sensing up to several centimetres
- ◆ High Resolution Capacitive Sensing
 - Up to 100pF of Offset Cap. Compensation at Full Sensitivity
 - Capable of Sensing up thru 5mm thick Overlay Materials
- ◆ Up to 2 Analog Output Interfaces (AOI-A and AOI-B)
 - Enable button detection thru host's ADC
- ◆ Support of buzzer for audible feedback
- ◆ User-selectable Button Reporting Configuration
 - Report Single or Report Strongest
- ◆ Extremely Low Power
 - 8uA (typ) in Sleep Mode
 - 70uA (typ) in Doze Mode (195ms)
 - 200uA (typ) in Active Mode (30ms)
- ◆ Programmable Scanning Period from 15ms to several seconds
- ◆ Auto Offset Compensation
 - Eliminates false triggers due to environmental factors (temperature, humidity)
 - Initiated on power-up and configurable intervals
- ◆ Multi-Time In-Field Programmable Firmware Parameters for Ultimate Flexibility
 - On-chip user programmable memory for fast, self contained start-up
- ◆ No External Components per Sensor Input
- ◆ Internal Clock Requires No External Components
- ◆ Differential Sensor Sampling for Reduced EMI
- ◆ Optional 400 KHz I²C Interface with Programmable Address
- ◆ -40°C to +85°C Operation

APPLICATIONS

- ◆ LCD TVs, Monitors
- ◆ White Goods
- ◆ Notebook/Netbook/Portable/Handheld computers
- ◆ Consumer Products, Instrumentation, Automotive
- ◆ Mechanical Button Replacement

ORDERING INFORMATION

Part Number	Temperature Range	Package
SX8661I07ZULTRT ¹	-40°C to +85°C	Lead Free MLPQ-UT28

¹ 3000 Units/reel

* This device is RoHS/WEEE compliant and Halogen Free

**Table of Contents**

GENERAL DESCRIPTION.....	1
TYPICAL APPLICATION CIRCUIT	1
KEY PRODUCT FEATURES.....	1
APPLICATIONS.....	1
ORDERING INFORMATION.....	1
1 GENERAL DESCRIPTION.....	5
1.1 Pin Diagram	5
1.2 Marking information	5
1.3 Pin Description	6
1.4 Simplified Block Diagram	7
1.5 Acronyms	7
2 ELECTRICAL CHARACTERISTICS	8
2.1 Absolute Maximum Ratings	8
2.2 Recommended Operating Conditions	8
2.3 Thermal Characteristics	8
2.4 Electrical Specifications	9
3 FUNCTIONAL DESCRIPTION.....	12
3.1 Introduction	12
3.1.1 General	12
3.1.2 GPIOs	12
3.1.3 Analog Output Interface A and B (SPO mode)	12
3.1.4 Buzzer (SPO mode)	12
3.1.5 Parameters	13
3.1.6 Configuration	13
3.2 Scan Period	13
3.3 Operation modes	14
3.4 Sensors on the PCB	14
3.5 Button Information	15
3.6 Buzzer	15
3.7 Analog Output Interface	17
3.8 Analog Sensing Interface	19
3.9 Offset Compensation	21
3.10 Processing	22
3.11 Configuration	22
3.12 Power Management	24
3.13 Clock Circuitry	24
3.14 I2C interface	24
3.15 Interrupt	25
3.15.1 Power up	25
3.15.2 Assertion	25
3.15.3 Clearing	25

**ADVANCED COMMUNICATIONS & SENSING****DATASHEET**

3.15.4	Example	26
3.16	Reset	26
3.16.1	Power up	26
3.16.2	RESETB	27
3.16.3	Software Reset	27
3.17	General Purpose Input and Outputs	28
3.17.1	GPP mode	28
3.17.2	GPO Dual Reporting	30
3.17.3	GPO Fading	31
3.17.4	Intensity index vs PWM pulse width	32
3.17.5	GPO Triple Reporting	33
4	PIN DESCRIPTIONS	35
4.1	Introduction	35
4.2	ASI pins	35
4.3	Host interface pins	36
4.4	Power management pins	39
4.5	General purpose IO pins	40
5	DETAILED CONFIGURATION DESCRIPTIONS	41
5.1	Introduction	41
5.2	General Parameters	44
5.3	Capacitive Sensors Parameters	45
5.4	Proximity Parameters	49
5.5	Button Parameters	51
5.6	Analog Output Interface Parameters	57
5.7	Buzzer Parameters	59
5.8	Mapping Parameters	60
5.9	GPIO Parameters	62
6	I2C INTERFACE	66
6.1	I2C Write	66
6.2	I2C read	67
6.3	I2C Registers Overview	68
6.4	Status Registers	69
6.5	Control Registers	71
6.6	SPM Gateway Registers	73
6.6.1	SPM Write Sequence	74
6.6.2	SPM Read Sequence	75
6.7	NVM burn	76
6.8	Monitor Mode	77
7	APPLICATION INFORMATION	78
7.1	Triple proximity reporting	78
7.2	Dual proximity reporting	79
7.2.1	SPM file (application two AOI, dual proximity reporting)	81
7.3	Example of Touch+Proximity Module	82
7.3.1	Overview	82
7.3.2	Operation	82
7.3.3	Performance	83
7.3.4	Schematics	83
7.3.5	Layout	84



ADVANCED COMMUNICATIONS & SENSING

DATASHEET

8	REFERENCES	85
9	PACKAGING INFORMATION	86
9.1	Package Outline Drawing	86
9.2	Land Pattern	86



1 GENERAL DESCRIPTION

1.1 Pin Diagram

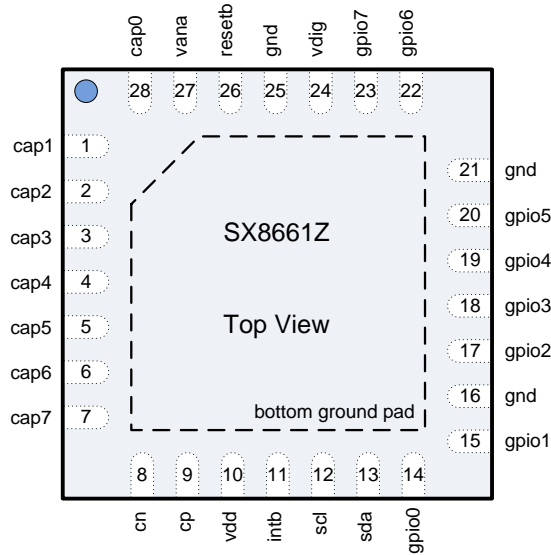
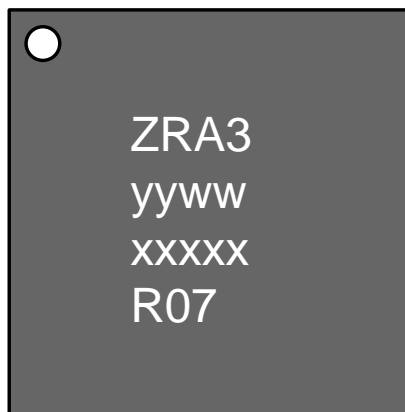

Figure 1 Pinout Diagram

1.2 Marking information



yyww = Date Code
 xxxxx = Semtech lot number
 R07 = Semtech Code

Figure 2 Marking Information

**1.3 Pin Description**

Number	Name	Type	Description
1	CAP1	Analog	Capacitive Sensor 1
2	CAP2	Analog	Capacitive Sensor 2
3	CAP3	Analog	Capacitive Sensor 3
4	CAP4	Analog	Capacitive Sensor 4
5	CAP5	Analog	Capacitive Sensor 5
6	CAP6	Analog	Capacitive Sensor 6
7	CAP7	Analog	Capacitive Sensor 7
8	CN	Analog	Integration Capacitor, negative terminal (1nF between CN and CP)
9	CP	Analog	Integration Capacitor, positive terminal (1nF between CN and CP)
10	VDD	Power	Main input power supply
11	INTB	Digital Output	Interrupt, active LOW, requires pull up resistor (in host or external)
12	SCL	Digital Input	I2C Clock, requires pull up resistor (in host or external)
13	SDA	Digital Input/Output	I2C Data, requires pull up resistor (in host or external)
14	GPIO0	Digital Input/Output	General Purpose Input/Output 0
15	GPIO1	Digital Input/Output	General Purpose Input/Output 1
16	GND	Ground	Ground
17	GPIO2	Digital Input/Output	General Purpose Input/Output 2
18	GPIO3	Digital Input/Output	General Purpose Input/Output 3
19	GPIO4	Digital Input/Output	General Purpose Input/Output 4
20	GPIO5	Digital Input/Output	General Purpose Input/Output 5
21	GND	Ground	Ground
22	GPIO6	Digital Input/Output	General Purpose Input/Output 6
23	GPIO7	Digital Input/Output	General Purpose Input/Output 7
24	VDIG	Analog	Digital Core Decoupling, connect to a 100nF decoupling capacitor
25	GND	Ground	Ground
26	RESETB	Digital Input	Active Low Reset. Connect to VDD if not used.
27	VANA	Analog	Analog Core Decoupling, connect to a 100nF decoupling capacitor
28	CAPO	Analog	Capacitive Sensor 0
bottom plate	GND	Ground	Exposed pad connect to ground

Table 1 Pin description



1.4 Simplified Block Diagram

The simplified block diagram of the SX8661Z is illustrated in Figure 3.

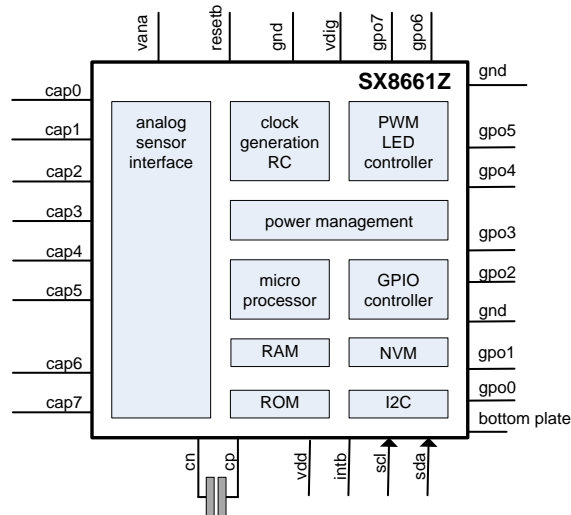

Figure 3 Simplified block diagram of the SX8661Z

1.5 Acronyms

AOI	Analog Output Interface
ASI	Analog Sensor Interface
DCV	Digital Compensation Value
GPO	General Purpose Output
GPP	General Purpose PWM
MTP	Multiple Time Programmable
NVM	Non Volatile Memory
PWM	Pulse Width Modulation
QSM	Quick Start Memory
SPM	Shadow Parameter Memory
SPO	Special Purpose Output

**2 ELECTRICAL CHARACTERISTICS****2.1 Absolute Maximum Ratings**

Stresses above the values listed in “Absolute Maximum Ratings” may cause permanent damage to the device.

This is a stress rating only and functional operation of the device at these, or any other conditions beyond the “Recommended Operating Conditions”, is not implied. Exposure to absolute maximum rating conditions for extended periods may affect device reliability.

Parameter	Symbol	Min.	Max.	Unit
Supply Voltage	VDD	-0.5	3.9	V
Input voltage (non-supply pins)	V _{IN}	-0.5	3.9	V
Input current (non-supply pins)	I _{IN}		10	mA
Operating Junction Temperature	T _{JCT}		125	°C
Reflow temperature	T _{RE}		260	°C
Storage temperature	T _{STOR}	-50	150	°C
ESD HBM (Human Body model) ⁽ⁱ⁾	ESD _{HBM}	3		kV
Latchup ⁽ⁱⁱ⁾	I _{LU}	± 100		mA

Table 2 Absolute Maximum Ratings

(i) Tested to JEDEC standard JESD22-A114

(ii) Tested to JEDEC standard JESD78

2.2 Recommended Operating Conditions

Parameter	Symbol	Min.	Max.	Unit
Supply Voltage	VDD	2.7	3.6	V
Supply Voltage Drop ^(iii, iv, v)	VDD _{drop}		100	mV
Supply Voltage for NVM programming	VDD	3.6	3.7	V
Ambient Temperature Range	T _A	-40	85	°C

Table 3 Recommended Operating Conditions

(iii) Performance for 2.6V < VDD < 2.7V might be degraded.

(iv) Operation is not guaranteed below 2.6V. Should VDD briefly drop below this minimum value, then the SX8661Z may require;

- a hardware reset issued by the host using the RESETB pin
- a software reset issued by the host using the I2C interface

(v) In the event the host processor is reset or undergoes a power OFF/ON cycle, it is recommended that the host also resets the SX8661Z and assures that parameters are re-written into the SPM (should these differ to the parameters held in NVM).

2.3 Thermal Characteristics

Parameter	Symbol	Min.	Max.	Unit
Thermal Resistance - Junction to Ambient ^(vi)	θ _{JA}		25	°C/W

Table 4 Thermal Characteristics

(vi) Static airflow

**2.4 Electrical Specifications**

All values are valid within the operating conditions unless otherwise specified.

Parameter	Symbol	Conditions	Min.	Typ.	Max.	Unit
Current consumption						
Active mode, average	$I_{OP,active}$	30ms scan period, 8 sensors enabled, common sensitivity 0 proximity sensing OFF		200	275	μ A
Doze mode, average	$I_{OP,Doze}$	195ms scan period, 8 sensors enabled, common sensitivity 0 proximity sensing OFF		70	100	μ A
Sleep	$I_{OP,sleep}$	I2C listening, sensors disabled		8	17	μ A
Active mode, average (Quick Start application)	$I_{QS,active}$	30ms scan period, 8 sensors enabled, sensitivity 2 for buttons sensitivity 7 for proximity proximity sensing ON		800	1100	μ A
Doze mode, average (Quick Start application)	$I_{QS,Doze}$	195ms scan period, 8 sensors enabled, sensitivity 2 for buttons sensitivity 7 for proximity proximity sensing ON		160	220	μ A
ResetB, SCL, SDA						
Input logic high	V_{IH}		$0.7 \cdot V_{DD}$		$V_{DD} + 0.3$	V
Input logic low	V_{IL}	VSS applied to GND pins	$V_{SS} - 0.3$		0.8	V
Input leakage current	I_L	CMOS input			± 1	μ A
Pull up resistor	R_{PU}	when enabled		660		k Ω
Pull down resistor	R_{PD}	when enabled		660		k Ω
GPIO set as Output, IntB, SDA						
Output logic high	V_{OH}	$I_{OH} < 4\text{mA}$	$V_{DD} - 0.4$			V
Output logic low	V_{OL}	$I_{OL,GPIO} < 12\text{mA}$ $I_{OL,SDA,INTB} < 4\text{mA}$			0.4	V
Start-up						
Power up time	t_{por}	time between rising edge VDD and rising INTB			275	ms
RESETB						
ResetB pulse width	t_{res}		50			ns

**ADVANCED COMMUNICATIONS & SENSING****DATASHEET**

Parameter	Symbol	Conditions	Min.	Typ.	Max.	Unit
Recommended External components						
capacitor between VDIG, GND	C _{vdig}	type 0402, tolerance +/-50%		100		nF
capacitor between VANA, GND	C _{vana}	type 0402, tolerance +/-50%		100		nF
capacitor between CP, CN	C _{int}	type 0402, COG, tolerance +/-5%		1		nF
capacitor between VDD, GND	C _{vdd}	type 0402, tolerance +/-50%	270			nF

Table 5 Electrical Specifications



Parameter	Symbol	Conditions	Min.	Typ.	Max.	Unit
I2C Timing Specifications ⁽ⁱ⁾						
SCL clock frequency	f_{SCL}				400	KHz
SCL low period	t_{LOW}		1.3			us
SCL high period	t_{HIGH}		0.6			us
Data setup time	$t_{SU;DAT}$		100			ns
Data hold time	$t_{HD;DAT}$		0			ns
Repeated start setup time	$t_{SU;STA}$		0.6			us
Start condition hold time	$t_{HD;STA}$		0.6			us
Stop condition setup time	$t_{SU;STO}$		0.6			us
Bus free time between stop and start	t_{BUF}		500			us
Input glitch suppression	t_{SP}				50	ns

*Table 6 I2C Timing Specification***Notes:**

(i) All timing specifications, Figure 4 and Figure 5, refer to voltage levels (V_{IL} , V_{IH} , V_{OL}) defined in Table 5.

The interface complies with slave F/S mode as described by NXP: "I2C-bus specification, Rev. 03 - 19 June 2007"

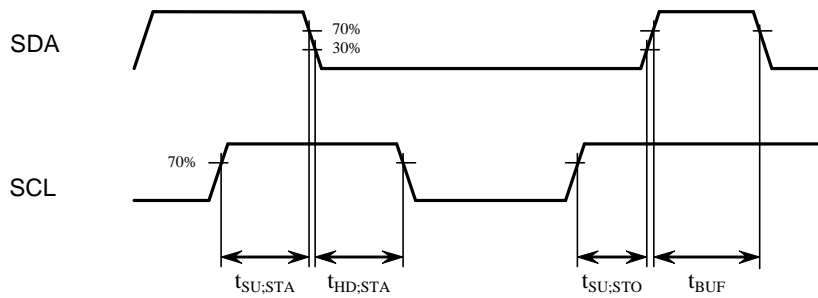
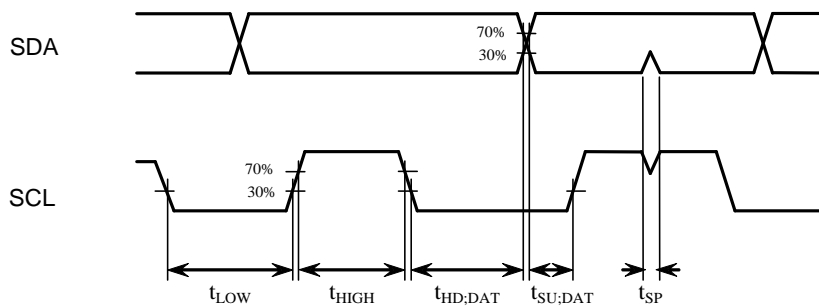
*Figure 4 I2C Start and Stop timing**Figure 5 I2C Data timing*



3 FUNCTIONAL DESCRIPTION

3.1 Introduction

3.1.1 General

The SX8661Z is intended to be used in applications which require capacitive sensors covered by isolating overlay material and which need to detect the proximity of a finger/hand through the air. A finger approaching the capacitive sensors will change the charge that can be loaded on the sensors. The SX8661Z measures the change of charge and converts that into digital values (ticks). The larger the charge on the sensors, the larger the number of ticks will be. The charge to ticks conversion is done by the SX8661Z Analog Sensor Interface (ASI).

The ticks are further processed by the SX8661Z and converted in a high level, easy to use information for the user's host.

The information between SX8661Z and the user's host is passed through the I2C interface with an additional interrupt signal indicating that the SX8661Z has new information. For buttons this information is simply touched or released. The SX8661Z can operate without the I2C and interrupt by using the analog output interface (GPIO7 and/or GPIO6) which voltage level indicates the button touched or GPO with the autolight function.

3.1.2 GPIOs

Feedback to the user is using General Purpose Input Output (GPIO) pins. The SX8661Z offers up to eight individual configurable GPIO pins. The GPIO can e.g. be set as a LED driver which slowly fade-in when a finger touches a button or proximity is detected and slowly fade-out when the button is released or finger goes out of proximity. Fading intensity variations can be logarithmic or linear. Interval speed and initial and final light intensity can be selected by the user. The fading is done using a 256 step PWM. The SX8661Z has eight individual PWM generators, one for each GPIO pin.

The LED fading-in and fading-out mode is called the GPO (fading) mode.

The LED fading can be initiated automatically by the SX8661Z by setting the SX8661Z autolighting feature. A simple touch on a sensor and the corresponding LED will fade-in without any host interaction over the I2C.

In case the autolighting feature is disabled then the host will decide to start a LED fading-in period, simply by setting the GPO pin to 'high' using one I2C command. The SX8661Z will then slowly fade-in the LED using the PWM autonomously.

In case the host needs to have full control of the LED intensity then the host can set the GPIO in the PWM mode (GPP). The host is then able to set the PWM pulse width freely at the expense of an increased I2C occupation.

The GPIOs can be set further in special purpose output (SPO) for the buzzer or analog output interface.

3.1.3 Analog Output Interface A and B (SPO mode)

The Analog Output Interface (AOI) is a PWM output signal between ground and VDD. The duty cycle of the AOI output will change depending on which button is touched. A host controller can then measure the mean voltage delivered on the AOI output and determine which button is touched at any given time.

The AOI feature allows the SX8661Z device to replace directly legacy mechanical button controllers in a quick and effortless manner. The SX8661Z supports up to two Analog Output Interfaces, AOI-A and AOI-B (on GPIO7 and GPIO6 respectively). The SX8661Z allows buttons to be mapped on either AOI-A or AOI-B. The button mapping as well as the mean voltage level that each button produces on a AOI output can be configured by the user through a set of parameters described in later chapters (see 5.6).

3.1.4 Buzzer (SPO mode)

The SX8661Z can drive a buzzer (on GPIO5) to provide audible feedback on button touches. The buzzer duration is set to approximately 30ms per default (see 5.7).



3.1.5 Parameters

The SX8661Z has many low level built-in, fixed algorithms and procedures. To allow a lot of freedom for the user and adapt the SX8661Z for different applications these algorithms and procedures can be configured with a large set of parameters which will be described in the following sections. Examples of parameters are which sensors are buttons, which GPIO is used for outputs, for the Analog Output Interfaces, the Buzzer or LEDs and which GPIO is mapped to which button.

Sensitivity and detection thresholds of the sensors are part of these parameters. Assuming that overlay material and sensors areas are identical then the sensitivities and thresholds will be the same for each sensor. In case sensors are not of the same size then sensitivities or thresholds might be chosen individually per sensor.

So a smaller size sensor can have a larger sensitivity while a big size sensor may have the lower sensitivity.

3.1.6 Configuration

During a development phase the parameters can be determined and fine tuned by the users and downloaded over the I2C in a dynamic way. The parameter set can be downloaded over the I2C by the host each time the SX8661Z boots up. This allows a flexible way of setting the parameters at the expense of I2C occupation.

In case the parameters are frozen they can be programmed in Multiple Time Programmable (MTP) Non Volatile Memory (NVM) on the SX8661Z. The programming needs to be done once (over the I2C). The SX8661Z will then boot up from the NVM and additional parameters from the host are not required anymore.

In case the host desires to overwrite the boot-up NVM parameters (partly or even complete) this can be done by additional I2C communications.

3.2 Scan Period

The basic operation Scan period of the SX8661Z sensing interface can be split into three periods over time.

In the first period (Sensing) the SX8661Z is sensing all enabled CAP inputs, from CAP0 towards CAP7.

In the second period (Processing) the SX8661Z processes the sensor data, verifies and updates the GPIO and the I2C.

In the third period (Timer) the SX8661Z is set in a low power mode and waits until a new cycle starts.

Figure 6 shows the different SX8661Z periods over time.

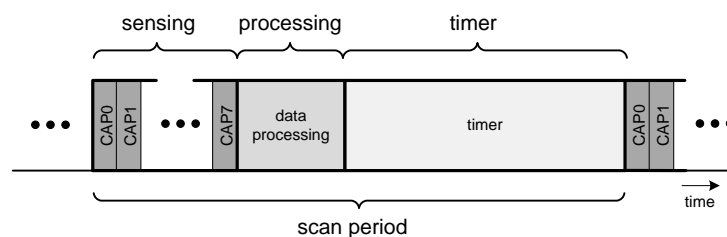

Figure 6 Scan Period

The scan period determines the minimum reaction time of the SX8661Z. The scan period can be configured by the host from 15ms to values larger than a second.

The reaction time is defined as the interval between a touch on the sensor and the moment that the SX8661Z generates the interrupt on the INTB pin. The shorter the scan period the faster the reaction time will be.

Very low power consumptions can be obtained by setting very long scan periods with the expense of having longer reaction times.

All external events like GPIO, I2C and the interrupt are updated in the processing period, so once every scan period.



3.3 Operation modes

The SX8661Z has 3 operation modes. The main difference is found in the reaction time (corresponding to the scan period) and power consumption.

Active mode offers fast scan periods. The typical reaction time is 30ms. All enabled sensors are scanned and information data is processed within this interval.

Doze mode increases the scan period time which increases the reaction time to 195ms typical and at the same time reduces the operating current.

Sleep mode turns the SX8661Z OFF, except for the I2C peripheral, minimizing operating current while maintaining the power supplies. In Sleep mode the SX8661Z does not do any sensor scanning. The Sleep mode will be exited by any I2C access.

The user can specify other scan periods for the Active and Doze mode and decide for other compromises between reaction time and power consumption.

In most applications the reaction time needs to be fast when fingers are present, but can be slow when no person uses the application. In case the SX8661Z is not used for a specific time it will go from Active mode into Doze mode and power will be saved. This time-out is determined by the Passive Timer which can be configured by the user or turned OFF if not required.

To leave Doze mode and enter Active mode this can be done by a simple touch on any button.

The host can decide to force the operating mode by issuing commands over the I2C (using register GpioOpMode) and take fully control of the SX8661Z. The diagram in Figure 7 shows the available operation modes and the possible transitions.

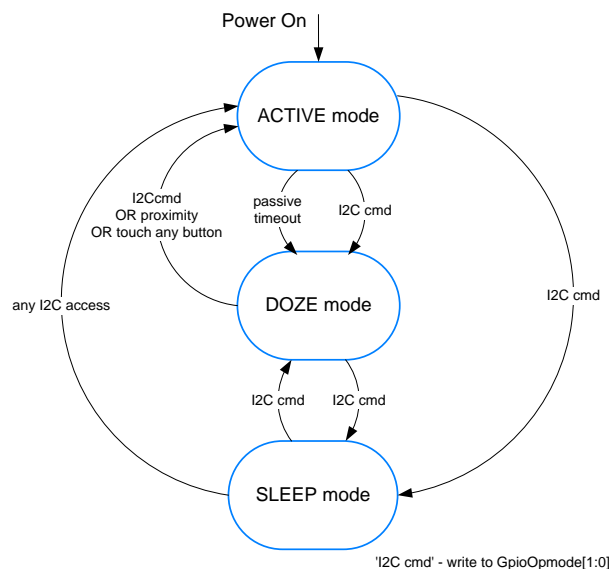

Figure 7 Operation modes

3.4 Sensors on the PCB

The capacitive sensors are relatively simple copper areas on the PCB connected to the eight SX8661Z capacitive sensor input pins (CAP0...CAP7).The sensors are covered by isolating overlay material (typically 1mm...3mm). The area of a sensor is typically one square centimetre which corresponds about to the area of a finger touching the overlay material. The area of a proximity sensor is usually a factor larger as the smaller touch sensors.

The capacitive sensors can be setup as ON/OFF buttons for touch sensing and CAP0 offers additionally proximity sensing (see example Figure 8) for control applications.

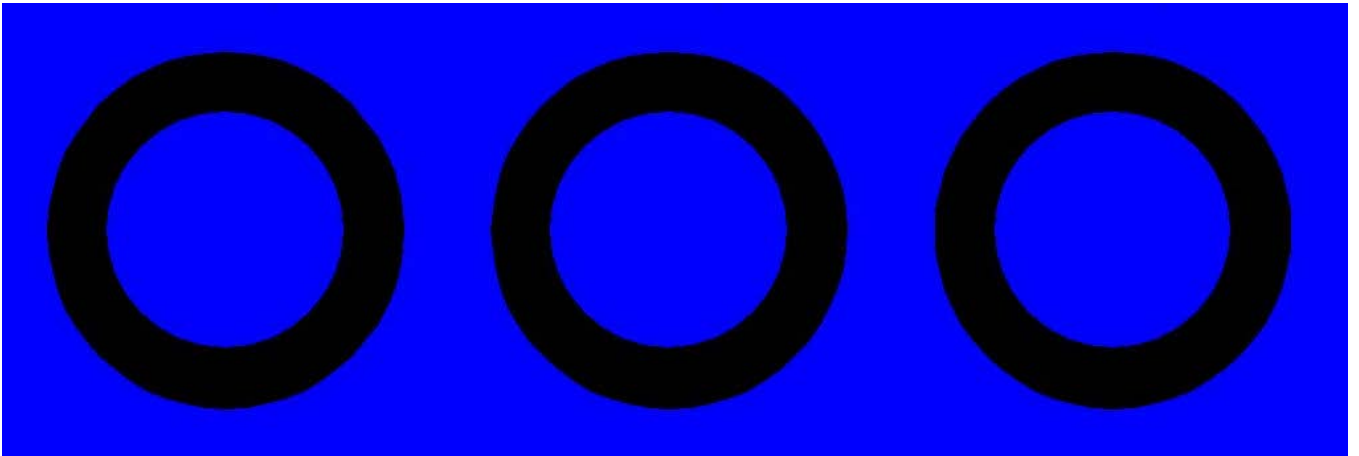

Figure 8 PCB top layer of three touch buttons sensors surrounded by a proximity sensor

Please refer to the layout guidelines application note [1], for more details.

3.5 Button Information

The touch buttons have two simple states (see Figure 9): ON (touched by finger) and OFF (released and no finger press).

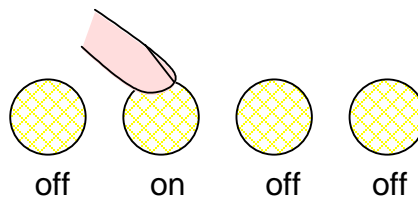

Figure 9 Buttons

A finger is detected as soon as the number of ticks from the ASI reaches a user-defined threshold plus a hysteresis.

A release is detected if the tick from the ASI goes below the threshold minus a hysteresis. The hysteresis around the threshold avoids rapid touch and release signalling during transients.

Buttons can also be used to do proximity sensing. The principle of proximity sensing operation is exactly the same as for touch buttons except that proximity sensing is done several centimeters above the overlay through the air. ON state means that finger/hand is detected by the sensor and OFF state means the finger/hand is far from the sensor and not detected.

3.6 Buzzer

The SX8661Z has the ability to drive a buzzer (on GPIO5) to provide an audible indication that a button has been touched. The buzzer is driven by a square signal for approximately 30ms (default). During the first phase (15ms) the signal's frequency is default 4KHz while in the second phase (15ms) the signal's frequency default is 8KHz.

The buzzer is activated only once during any button touch and is not repeated for long touches. The user can choose to enable or disable the buzzer by configuration and define the idle level, frequencies and phase durations (see 5.7).

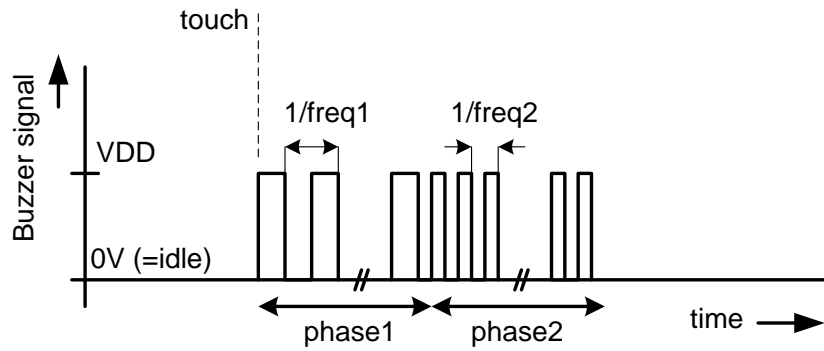

Figure 10 Buzzer behavior



3.7 Analog Output Interface

The Analog Output Interface outputs a PWM signal with a varying duty cycle depending on which button is touched. By filtering (with a simple RC filter) the PWM signal results in a DC voltage, different for each button touch. The host controller measures the DC voltage level and determines which buttons has been touched.

In the case of single button touches, each button produces its own voltage level as configured by the user (see 5.6 and Table 7).

Figure 11 show how the AOI will behave when the user touches and releases different buttons. The AOI will switch between the AOI idle level and the level for each button.

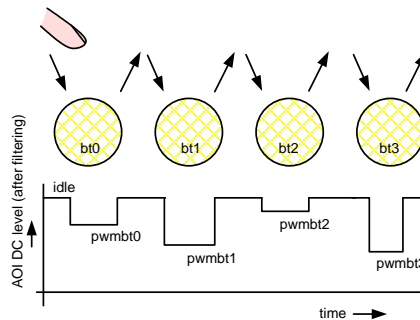

Figure 11 AOI behavior

The PWM blocks used in AOI modes are 8-bits based and clocked at 2MHz typically.

The PWM period can be set to 256 (default) or 64. The 256 period offers a better granularity at a lower frequency, while the 64 period is faster and with fewer steps.

Figure 12 shows the PWM definition of the AOI.

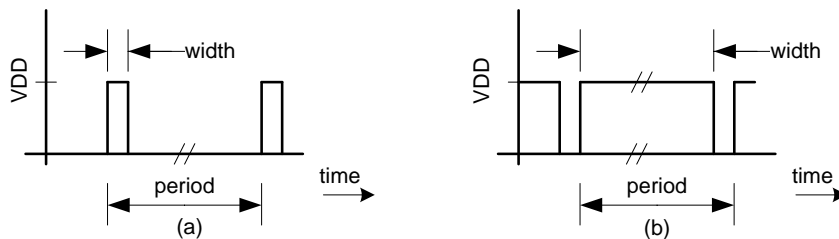

Figure 12 PWM definition, (a) small pulse width, (b) large pulse width

Table 7 describes the AOI level index versus the PWM pulse width. The user can select 256 steps (index) in case the period is set to 255.

In case the period is set to 64 then the index from 0 to 63 applies.

Index	Width	Index	Width	Index	Width	Index	Width	Index	Width	Index	Width	Index	Width	Index	Width
0	0	32	33	64	65	96	97	128	129	160	161	192	193	224	225
1	2	33	34	65	66	97	98	129	130	161	162	193	194	225	226
2	3	34	35	66	67	98	99	130	131	162	163	194	195	226	227
3	4	35	36	67	68	99	100	131	132	163	164	195	196	227	228
4	5	36	37	68	69	100	101	132	133	164	165	196	197	228	229
5	6	37	38	69	70	101	102	133	134	165	166	197	198	229	230
6	7	38	39	70	71	102	103	134	135	166	167	198	199	230	231
7	8	39	40	71	72	103	104	135	136	167	168	199	200	231	232
8	9	40	41	72	73	104	105	136	137	168	169	200	201	232	233
9	10	41	42	73	74	105	106	137	138	169	170	201	202	233	234
10	11	42	43	74	75	106	107	138	139	170	171	202	203	234	235
11	12	43	44	75	76	107	108	139	140	171	172	203	204	235	236
12	13	44	45	76	77	108	109	140	141	172	173	204	205	236	237
13	14	45	46	77	78	109	110	141	142	173	174	205	206	237	238
14	15	46	47	78	79	110	111	142	143	174	175	206	207	238	239

**ADVANCED COMMUNICATIONS & SENSING****DATASHEET**

Index	Width	Index	Width	Index	Width	Index	Width	Index	Width	Index	Width	Index	Width	Index	Width
15	16	47	48	79	80	111	112	143	144	175	176	207	208	239	240
16	17	48	49	80	81	112	113	144	145	176	177	208	209	240	241
17	18	49	50	81	82	113	114	145	146	177	178	209	210	241	242
18	19	50	51	82	83	114	115	146	147	178	179	210	211	242	243
19	20	51	52	83	84	115	116	147	148	179	180	211	212	243	244
20	21	52	53	84	85	116	117	148	149	180	181	212	213	244	245
21	22	53	54	85	86	117	118	149	150	181	182	213	214	245	246
22	23	54	55	86	87	118	119	150	151	182	183	214	215	246	247
23	24	55	56	87	88	119	120	151	152	183	184	215	216	247	248
24	25	56	57	88	89	120	121	152	153	184	185	216	217	248	249
25	26	57	58	89	90	121	122	153	154	185	186	217	218	249	250
26	27	58	59	90	91	122	123	154	155	186	187	218	219	250	251
27	28	59	60	91	92	123	124	155	156	187	188	219	220	251	252
28	29	60	61	92	93	124	125	156	157	188	189	220	221	252	253
29	30	61	62	93	94	125	126	157	158	189	190	221	222	253	254
30	31	62	63	94	95	126	127	158	159	190	191	222	223	254	255
31	32	63	64	95	96	127	128	159	160	191	192	223	224	255	256

Table 7 AOI Level index vs. PWM pulse width (normal polarity)

The AOI reports always one button. The AOI can be split over two GPIO pins (AOI-A, AOI-B). The AOI-A interface is connected to pin GPIO7 and the AOI-B is connected to pin GPIO6. The user can map any button to either AOI-A or AOI-B or both.

In case buttons are split to both AOI pins, multiple button touches are still resulting in one AOI reporting.

In most applications only one AOI pin will be selected. The two AOI pins allow the user a more coarse detection circuitry at the host. Assuming a 3.3V supply and 8 buttons on one single AOI then the AOI levels could be separated with around 0.3...0.4V. In case of using the two AOI pins, 4 buttons could be mapped on AOI-A separated with around 0.8V (similar for 4 buttons on AOI-B) which step is about the double in case of a single AOI.

In case of a single touch the reported button is straight forward (as in Figure 11).

If more than one button is touched the reported depends on the selected button reporting mode parameter (5.5).

Three reporting modes exist for the SX8661Z (All, Single and Strongest).

The All reporting mode is applicable only for the I2C reporting (AOI is not available). In All-mode all buttons that are touched are reported in the I2C buttons status bits.

In the Single-mode a single touched button will be reported on the AOI and the I2C. All touches that occur afterwards will not be reported as long as the first touch sustains. Only when the first reported button is released will the SX860 report another touch.

Figure 13 shows the Single-mode reporting in case of 2 touches occurring over time.

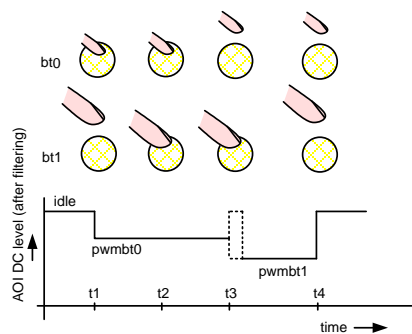
*Figure 13 Single-mode reporting with 2 touches*

At time t1 button0 is touched and reported on the AOI. At time t2 button1 is touched as well but not reported. At time t3 the button0 is released and button1 will be reported immediately (or after one scan period at idle level). At time t4 both buttons are released and the AOI reports the idle level.

The button with the lowest Cap pin index will be reported in case of a simultaneous touch (that means touches occurring within the same scan period).



In the Strongest-mode the strongest touched button will be reported on the AOI and the I2C. All touches that occur afterwards representing a weaker touch will not be reported. Only a touch which is stronger will be reported by the SX860.

Figure 14 shows the Strongest-mode reporting in case of 2 touches (with bt1 the strongest touch).

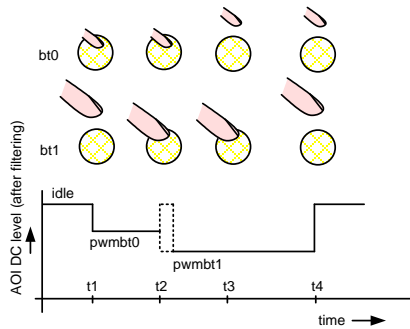

Figure 14 Strongest-mode reporting with 2 touches

At time t1 button0 is touched and reported on the AOI. At time t2 button1 is touched as well. As bt1 is the strongest touch it will be reported on the AOI immediately (or after one scan period at idle level). At time t3 the button0 is released while the AOI continues to report button1. At time t4 both buttons are released and the AOI reports the idle level.

In some special cases (when the buzzer is suspected to load heavily the power supply) the user may choose the AOI to go to 0V, to VDD or to the AOI idle level for the duration the buzzer is active.

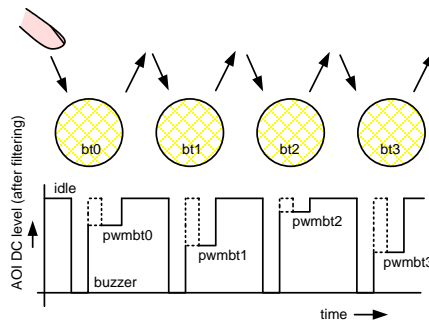

Figure 15 AOI behavior with 0V buzzer state

In Figure 15 the AOI will go to 0V each time the buzzer is active. The AOI returns then to either the idle mode for one scan period or goes immediately to the PWM button level.

In case the SX8661Z is set to sleep mode the AOIs will go to 0V.

3.8 Analog Sensing Interface

The Analog Sensing Interface (ASI) converts the charge on the sensors into ticks which will be further digitally processed. The basic principle of the ASI will be explained in this section.

The ASI consists of a multiplexer selecting the sensor, analog switches, a reference voltage, an ADC sigma delta converter, an offset compensation DAC and an external integration capacitor (see Figure 16).

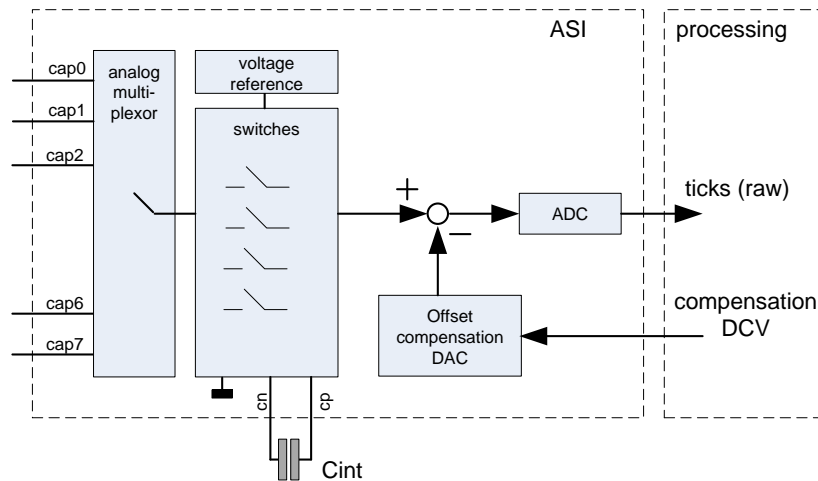

Figure 16 Analog Sensor Interface

To get the ticks representing the charge on a specific sensor the ASI will execute several steps.

The charge on a sensor cap (e.g. CAP0) will be accumulated multiple times on the external integration capacitor, Cint.

This results in an increasing voltage on Cint proportional to the capacitance on CAP0.

At this stage the offset compensation DAC is enabled. The compensation DAC generates a voltage proportional to an estimation of the external capacitance. The estimation is obtained by the offset compensation procedure executed e.g. at power-up.

The difference between the DAC output and the charge on Cint is the desired signal. In the ideal case the difference of charge will be converted to zero ticks if no finger is present and the number of ticks becomes high in case a finger is present.

The difference of charge on Cint and the DAC output will be transferred to the ADC (Sigma Delta Integrator).

After the charge transfer to the ADC the steps above will be repeated.

The larger the number the cycles are repeated the larger the signal out of the ADC with improved SNR. The sensitivity is therefore directly related to the number of cycles.

The SX8661Z allows setting the sensitivity for each sensor individually in applications which have a variety of sensors sizes or different overlays or for fine-tuning performances. The optimal sensitivity is depending heavily on the final application. If the sensitivity is too low the ticks will not pass the thresholds and touch/proximity detection will not be possible. In case the sensitivity is set too large, some power will be wasted and false touch/proximity information may be output (i.e. for touch buttons => finger not touching yet, for proximity sensors => finger/hand not close enough).

Once the ASI has finished the first sensor, the ticks are stored and the ASI will start measuring the next sensor until all (enabled) sensors pins have been treated.

In case some sensors are disabled then these result in lower power consumption simply because the ASI is active for a shorter period and the following processing period will be shorter.

The ticks from the ASI will then be handled by the digital processing.

The ASI will shut down and wait until new sensing period will start.



3.9 Offset Compensation

The capacitance at the CAP pins is determined by an intrinsic capacitance of the integrated circuit, the PCB traces, ground coupling and the sensor planes. This capacitance is relatively large and might become easily some tens of pF. This parasitic capacitance will vary only slowly over time due to environmental changes.

A finger touch is in the order of one pF. If the finger approaches the sensor this occurs typically fast.

The ASI has the difficult task to detect and distinguish a small, fast changing capacitance, from a large, slow varying capacitance. This would require a very precise, high resolution ADC and complicated, power consuming, digital processing.

The SX8661Z features a 16 bit DAC which compensates for the large, slow varying capacitance already in front of the ADC. In other words the ADC converts only the desired small signal. In the ideal world the ADC will put out zero ticks even if the external capacitance is as high as 100pF.

At each power-up of the SX8661Z the Digital Compensation Values (DCV) are estimated by the digital processing algorithms. The algorithm will adjust the compensation values such that zero ticks will be generated by the ADC.

Once the correct compensation values are found these will be stored and used to compensate each CAP pin.

If the SX8661Z is shut down the compensation values will be lost. At a next power-up the procedure starts all over again. This assures that the SX8661Z will operate under any condition. Powering up at e.g. different temperatures will not change the performance of the SX8661Z and the host does not have to do anything special.

The DCVs do not need to be updated if the external conditions remain stable.

However if e.g. temperature changes this will influence the external capacitance. The ADC ticks will drift then slowly around zero values basically because of the mismatch of the compensation circuitry and the external capacitance.

In case the average value of the ticks become higher than the positive noise threshold (configurable by user) or lower than the negative threshold (configurable by user) then the SX8661Z will initiate a compensation procedure and find a new set of DCVs.

Compensation procedures can as well be initiated by the SX8661Z on periodic intervals. Even if the ticks remain within the positive and negative noise thresholds the compensation procedure will then estimate new sets of DCVs.

Finally the host can initiate a compensation procedure by using the I2C interface. This is e.g. required after the host changed the sensitivity of sensors.



3.10 Processing

The first processing step of the raw ticks, coming out of the ASI, is low pass filtering to obtain an estimation of the average capacitance: tick-ave (see Figure 17). This slowly varying average is important in the detection of slowly changing environmental changes.

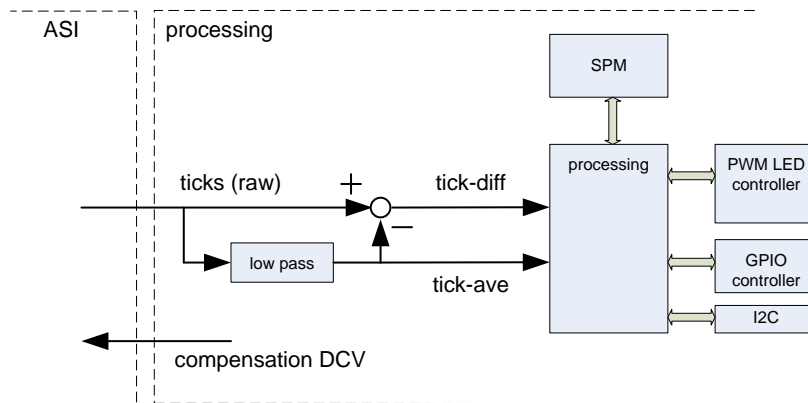

Figure 17 Processing

The difference of the tick average and the raw ticks, tick-diff, is a good estimation of rapid changing input capacitances.

The tick-diff, tick-ave and the configuration parameters in the SPM are then processed and determines the sensor information, I2C registers status and PWM control.

3.11 Configuration

Figure 18 shows the building blocks used for configuring the SX8661Z.

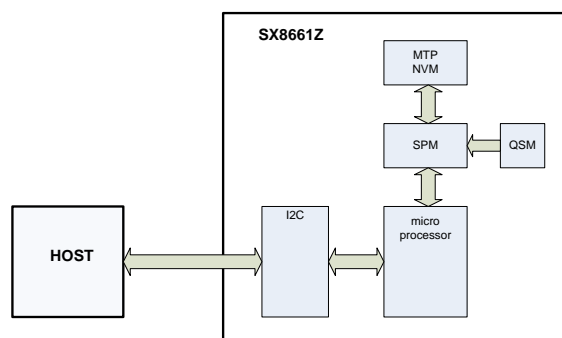

Figure 18 Configuration

The default configuration parameters of the SX8661Z are stored in the Quick Start Memory (QSM). This configuration data is setup to a very common application for the SX8661Z with 8 buttons. Without any programming or host interaction the SX8661Z will start up in the Quick Start Application.

The QSM settings are fixed and cannot be changed by the user.



In case the application needs different settings than the QSM settings then the SX8661Z can be setup and/or programmed over the I2C interface.

The configuration parameters of the SX8661Z can be stored in the Multiple Time Programmable (MTP) Non Volatile Memory (NVM). The NVM contains all those parameters that are defined and stable for the application. Examples are the number of sensors enabled, sensitivity, active and Doze scan period. The details of these parameters are described in the next chapters.

At power up the SX8661Z checks if the NVM contains valid data. In that case the configuration parameter source becomes the NVM. If the NVM is empty or non-valid then the configuration source becomes the QSM. In the next step the SX8661Z copies the configuration parameter source into the Shadow Parameter Memory (SPM). The SX8661Z is operational and uses the configuration parameters of the SPM.

During power down or reset event the SPM loses all content. It will automatically be reloaded following power up or at the end of the reset event.

The host will interface with the SX8661Z through the I2C bus and the analog output interface.

The I2C of the SX8661Z consists of 16 registers. Some of these I2C registers are used to read the status and information of the buttons. Other I2C registers allow the host to take control of the SX8661Z. The host can e.g. decide to change the operation mode from active mode to Doze mode or go into sleep (according Figure 7).

Two additional modes allow the host to have an access to the SPM or indirect access to the NVM. These modes are required during development, can be used in real time or in-field programming.

Figure 19 shows the Host SPM mode. In this mode the host can decide to overwrite the SPM. This is useful during the development phases of the application where the configuration parameters are not yet fully defined and as well during the operation of the application if some parameters need small deviations from the QSM or NVM content.

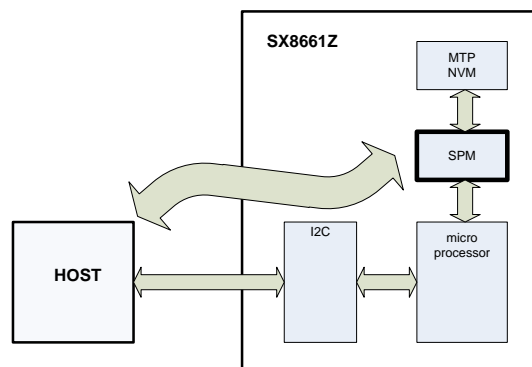
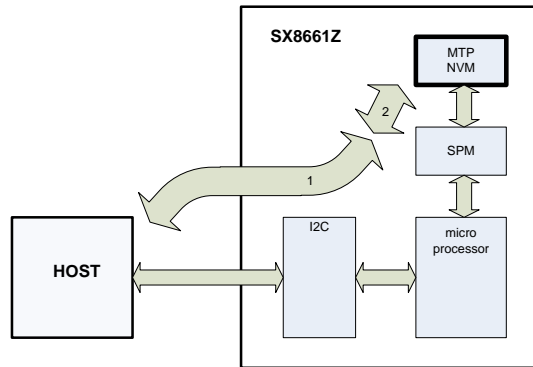

Figure 19 Host SPM mode

The content of the SPM remains valid as long as the SX8661Z is powered. After a power down the host needs to re-write the SPM at the next power-up.

Figure 20 shows the Host NVM mode. In this mode the host will be able to write the NVM.

*Figure 20 Host NVM mode*

The writing of the host towards the NVM is not done directly but done in 2 steps (Figure 20).

In the first step the host writes to the SPM (as in Figure 19). In the second step the host signals the SX8661Z to copy the SPM content into the NVM.

Initially the NVM memory is empty and it is required to determine a valid parameter set for the application. This can be done during the development phase using dedicated evaluation hardware representing the final application. This development phase uses probably initially the host SPM mode which allows faster iterations.

Once the parameter set is determined this can be written to the NVM over the I2C using the 2 steps approach by the host or a dedicated programmer for large volumes production (as described in the paragraphs 6.6 and 6.7).

3.12 Power Management

The SX8661Z uses on-chip voltage regulators which are controlled by the on-chip microprocessor. The regulators need to be stabilized with an external capacitor between VANA and ground and between VDIG and ground (see Table 5). Both regulators are designed to only drive the SX8661Z internal circuitry and must not be loaded externally.

3.13 Clock Circuitry

The SX8661Z has its own internal clock generation circuitry that does not require any external components. The clock circuitry is optimized for low power operation and is controlled by the on-chip microprocessor. The typical operating frequency of the oscillating core is 16.7MHz from which all other lower frequencies are derived.

3.14 I2C interface

The I2C interface allows the communication between the host and the SX8661Z.

The I2C slave implemented on the SX8661Z is compliant with the standard (100kb/s) and fast mode (400kb/s). The default SX8661Z I2C address equals 0b010 1011.

A different I2C address can be programmed by the user in the NVM.



3.15 Interrupt

3.15.1 Power up

During power up the INTB is kept low. Once the power up sequence is terminated the INTB is cleared autonomously. The SX8661Z is then ready for operation. The AOI levels are updated at the latest one scan period after the rising edge of INTB.

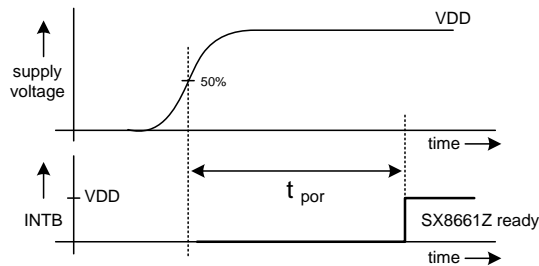

Figure 21 Power Up vs. INTB

During the power on period the SX8661Z stabilizes the internal regulators, RC clocks and the firmware initializes all registers.

During the power up the SX8661Z is not accessible and I2C communications are forbidden. The GPIOs set as inputs with a pull up resistor.

As soon as the INTB rises the SX8661Z will be ready for I2C communication. The GPIOs are then configured according the parameters in the SPM.

The value of INTB before power up depends on the INTB pull up resistor supply voltage.

3.15.2 Assertion

INTB is updated in Active or Doze mode once every scan period.

The INTB will be asserted at the following events:

- if a Button event occurred (touch or release if enabled). I2C register CapStatLsb show the detailed status of the Buttons,
- when actually entering Active or Doze mode via a host request (may be delayed by 1 scan period). I2C register CompOpmode shows the current operation mode,
- once compensation procedure is completed either through automatic trigger or via host request (may be delayed by 1 scan period),
- once SPM write is effective (may be delayed by 1 scan period),
- once NVM burn procedure is completed (may be delayed by 1 scan period),
- during reset (power up, hardware RESETB, software reset).

3.15.3 Clearing

The clearing of the INTB is done as soon as the host performs a read to any of the SX8661Z I2C registers.

3.15.4 Example

A typical example of the assertion and clearing of the INTB and the I2C communication is shown in Figure 22.

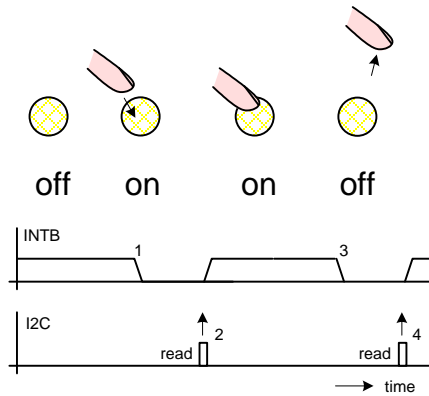

Figure 22 Interrupt and I2C

When a button is touched the SX8661Z will assert the interrupt (1). The host will read the SX8661Z status information over the I2C (2) and this clears the interrupt.

If the finger releases the button the interrupt will be asserted (3), the host reads the status (4) which clears the interrupt.

In case the host will not react to an interrupt then this will result in a missing touch.

3.16 Reset

The reset can be performed by 3 sources:

- power up,
- RESETB pin,
- software reset.

3.16.1 Power up

During power up the INTB is kept low. Once the power up sequence is terminated the INTB is released autonomously. The SX8661Z is then ready for operation.

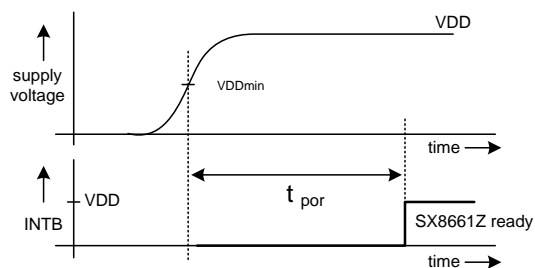

Figure 23 Power Up vs. INTB



During the power on period the SX8661Z stabilizes the internal regulators, RC clocks and the firmware initializes all registers.

During the power up the SX8661Z is not accessible and I2C communications are forbidden. As soon as the INTB rises the SX8661Z will be ready for I2C communication.

3.16.2 RESETB

When RESETB is driven low the SX8661Z will reset and start the power up sequence as soon as RESETB is driven high or pulled high.

In case the user does not require a hardware reset control pin then the RESETB pin can be connected to VDD.

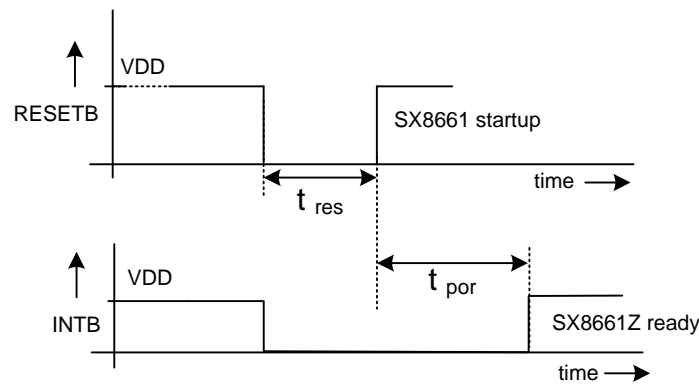

Figure 24 Hardware Reset

3.16.3 Software Reset

To perform a software reset the host needs to write 0xDE followed by 0x00 at the SoftReset register at address 0xB1.

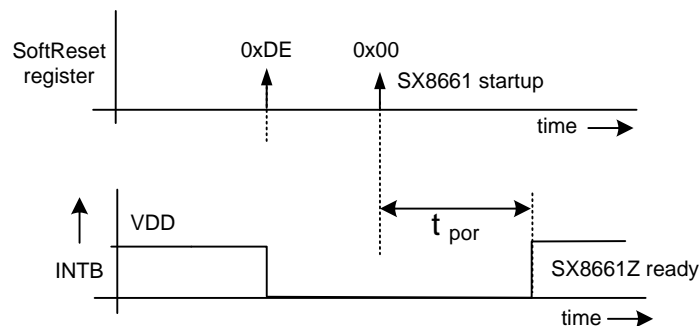

Figure 25 Software Reset



3.17 General Purpose Input and Outputs

The SX8661Z offers eight General Purpose Input and Outputs (GPIO) pins which can be configured in any of these modes:

- GPP (General Purpose PWM)
- GPO (General Purpose Output)
- SPO (Special Purpose Output)

The input state of the GPIO is only used during the initial phase of the power up period.

Each of these GPIO modes is described in more details in the following sections.

The polarity of the GPP and GPO pins is defined as in figure below, driving an LED as example. It has to be set accordingly in SPM parameter GpioPolarity.

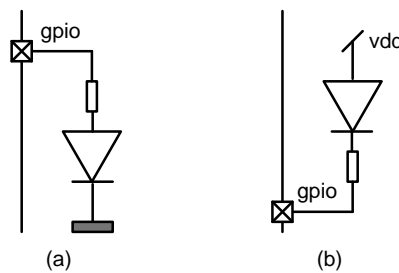

Figure 26 polarity = 1 (a), polarity = 0 (b)

The PWM blocks used in GPP and GPO modes are 8-bits based and clocked at 2MHz typ. hence offering 256 selectable pulse width values with a granularity of 0.5us typ.

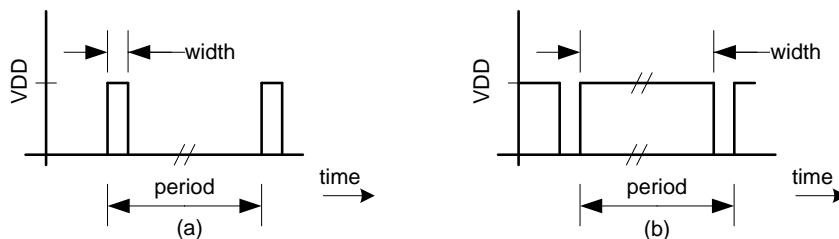
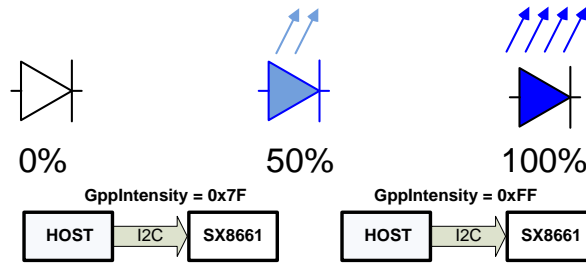

Figure 27 PWM definition, (a) small pulse width, (b) large pulse width

3.17.1 GPP mode

GPIOs configured as GPP will operate as PWM outputs directly controlled by the host. A typical application is LED dimming.

Typical GPP operation is illustrated in figure below.

*Figure 28 LED control in GPP mode*

SPM/I2C parameters applicable in GPP mode are listed in table below. Please refer to the relevant SPM/I2C parameters sections for more details.

		GPP
SPM	GpioMode	X
	GpioOutPwrUp	X ¹
	GpioPolarity	X
	GpioIntensityOn	X ¹
	GpioIntensityOff	X ¹
	GpioFunction	X
I2C	GppPinId	X
	GppIntensity	X ¹

¹ At power up, GppIntensity of each GPP pin is initialized with GpioIntensityOn or GpioIntensityOff depending on GpioOutPwrUp corresponding bits value.

Table 8 SPM/I2C Parameters Applicable in GPP Mode



3.17.2 GPO Dual Reporting

GPIOs configured as GPO will operate as digital outputs which can generate both standard low/high logic levels and PWM low/high duty cycles levels. Typical application is LED ON/OFF control. This is the dual reporting mode. The SX8661Z offers additionally a triple reporting mode which allows the reporting of proximity by a medium strong LED intensity (section 3.17.5).

Transitions between ON and OFF states can be triggered either automatically in Autolight mode or manually by the host. This is illustrated in figures below.

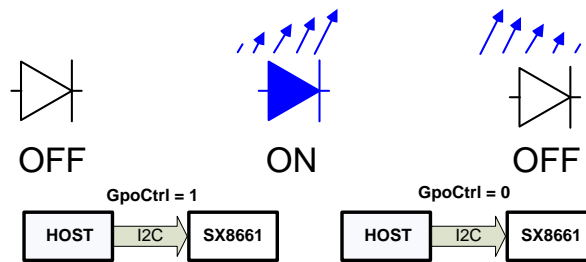

Figure 29 LED Control in GPO mode, Autolight OFF

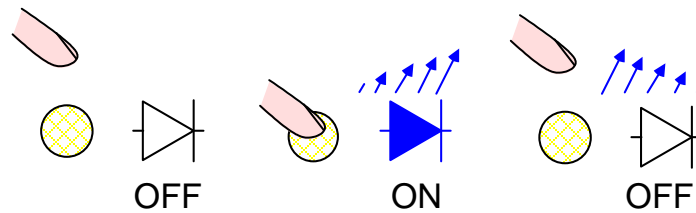

Figure 30 LED Control in GPO mode, Autolight ON (mapped to Button)

Additionally these transitions can be configured to be done with or without fading following a logarithmic or linear function. This is illustrated in figures below.

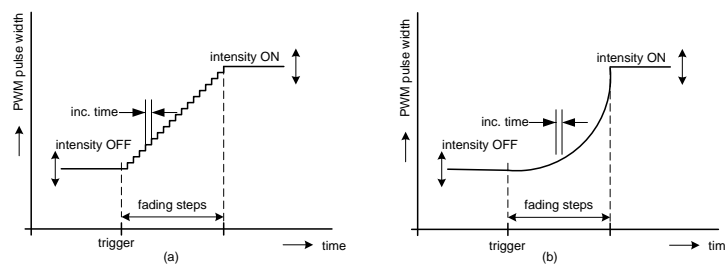

Figure 31 GPO ON transition (LED fade in), normal polarity, (a) linear, (b) logarithmic

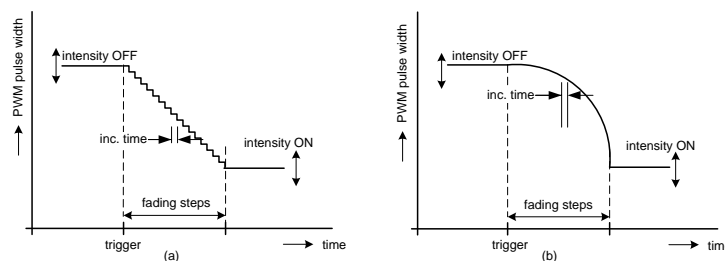

Figure 32 GPO ON transition (LED fade in), inverted polarity, (a) linear, (b) logarithmic



The fading out (e.g. after a button is released) is identical to the fading in but an additional off delay can be added before the fading starts (Figure 33 and Figure 34).

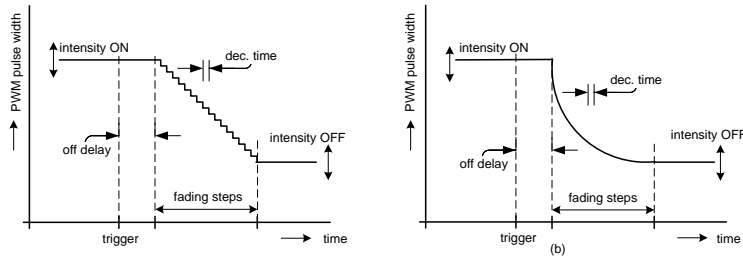

Figure 33 GPO OFF transition (LED fade out), normal polarity, (a) linear, (b) logarithmic

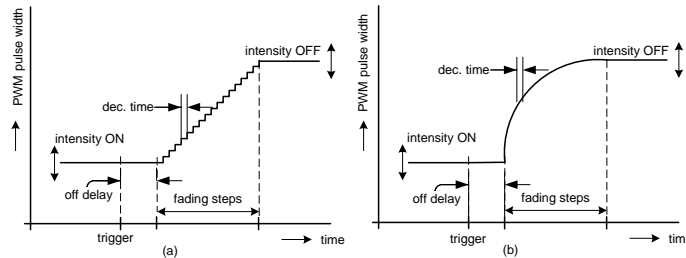

Figure 34 GPO OFF transition (LED fade out), inverted polarity, (a) linear, (b) logarithmic

Please note that standard high/low logic signals are just a specific case of GPO mode and can also be generated simply by setting inc/dec time to 0 (i.e. OFF) and programming intensity OFF/ON to 0x00 and 0xFF.

3.17.3 GPO Fading

The SX8661Z supports two different fading modes, namely Single and Continuous. These fading modes can be configured for each GPIO individually. Please see 5.9 “GPIO Parameters” for more information on how to configure this feature.

i) Single Fading Mode:

The GPO pin fades in when the associated button is touched and it fades out when it is released. This is shown in Figure 35

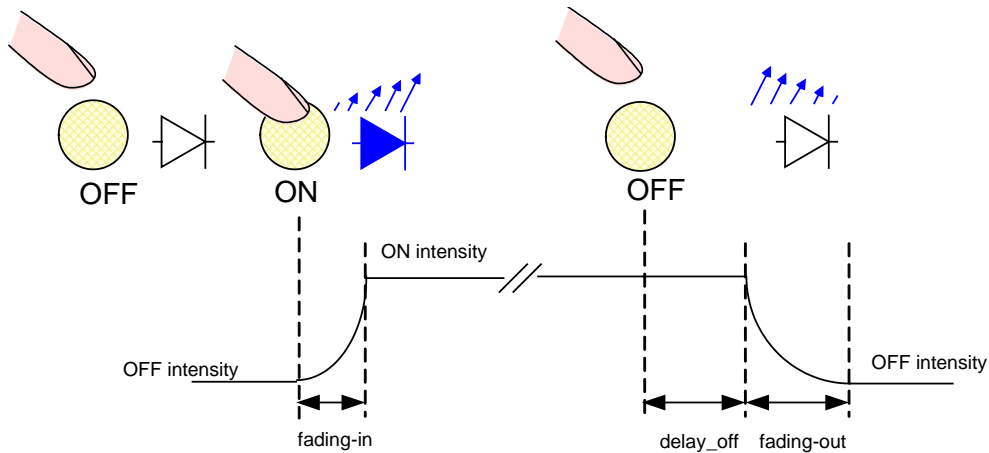
*Figure 35 Single Fading Mode*

ii) Continuous Fading Mode:

The GPO pin fades in and fades out continuously when the associated button is touched. The fading in and out stops when the button is released. This is shown in Figure 36.

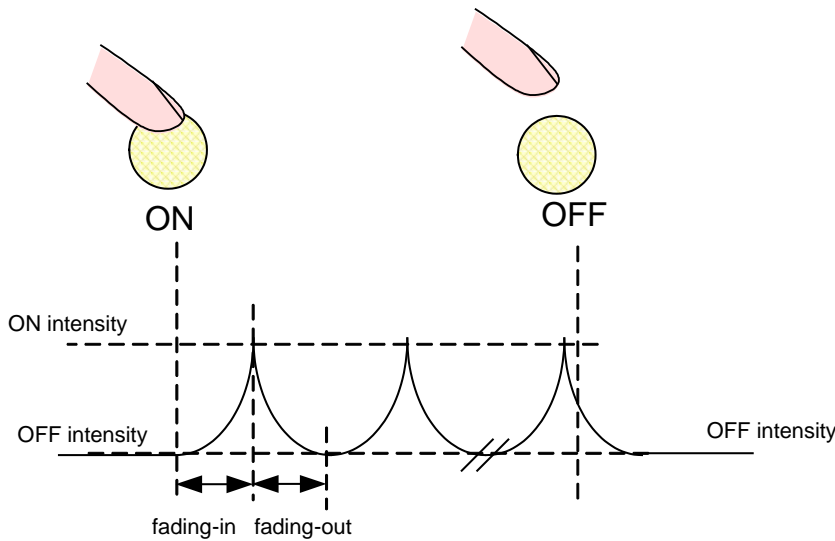
*Figure 36 Continuous Fading Mode***3.17.4 Intensity index vs PWM pulse width**

Tables below are used to convert all intensity indexes parameters GpioIntensityOff, GpioIntensityOn and GppIntensity but also to generate fading in GPO mode. During fading in(out), the index is automatically incremented(decremented) at every Inc(Dec)Time x Inc(Dec)Factor until it reaches the programmed GpioIntensityOn(Off) value.

Index	Lin/Log	Index	Lin/Log	Index	Lin/Log	Index	Lin/Log	Index	Lin/Log	Index	Lin/Log	Index	Lin/Log	Index	Lin/Log
0	0/0	32	33/5	64	65/12	96	97/26	128	129/48	160	161/81	192	193/125	224	225/184
1	2/0	33	34/5	65	66/13	97	98/27	129	130/49	161	162/82	193	194/127	225	226/186
2	3/0	34	35/5	66	67/13	98	99/27	130	131/50	162	163/83	194	195/129	226	227/188
3	4/0	35	36/5	67	68/13	99	100/28	131	132/51	163	164/84	195	196/130	227	228/190
4	5/0	36	37/5	68	69/14	100	101/29	132	133/52	164	165/86	196	197/132	228	229/192
5	6/2	37	38/6	69	70/14	101	102/29	133	134/53	165	166/87	197	198/133	229	230/194
6	7/2	38	39/6	70	71/14	102	103/30	134	135/54	166	167/88	198	199/135	230	231/197
7	8/2	39	40/6	71	72/15	103	104/30	135	136/55	167	168/89	199	200/137	231	232/199
8	9/2	40	41/6	72	73/15	104	105/31	136	137/55	168	169/91	200	201/139	232	233/201

*Figure 37 LEDs in triple reporting mode proximity*

Figure 37 shows an example of proximity detection and the reporting on LEDs. As soon as proximity is detected all LEDs (2 LEDs are shown for simplicity) will fade in and stop at the proximity intensity level. In case proximity is not detected anymore then the LEDs remain at the proximity intensity for a configurable time and then the fading out will start.

*Figure 38 LEDs in triple reporting mode proximity and touch*

Figure 38 shows an example of proximity detection followed by a rapid touch on the sensor sd1. The LEDs d1 and d2 will fade in as soon as proximity is detected (using the Inc_Prox parameter). As soon as the finger touches the sensor sd1 the fading in of d1 will go to the ON intensity (using the touch increment parameter). The LED d2 remains at the proximity intensity level as sensors sd2 is not touched.

If the finger is removed rapidly the fading out of d1 will first use the touch decrement parameter to the proximity intensity level. If the finger leaves the proximity region d1 and 2 will fade out simultaneously using the proximity delay and decrement parameters.

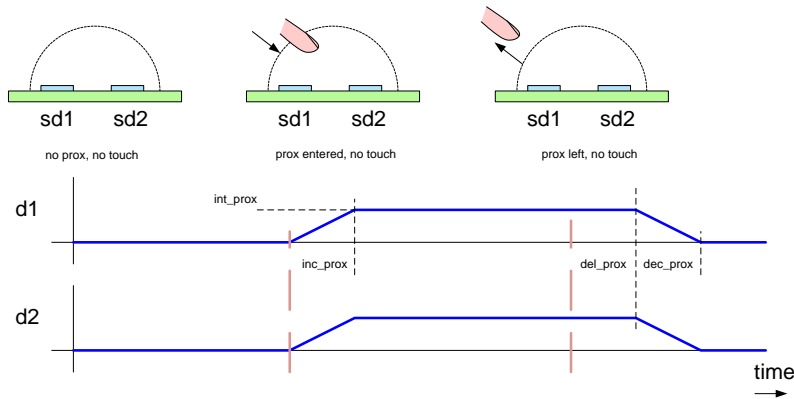
**4 PIN DESCRIPTIONS****4.1 Introduction**

This chapter describes briefly the pins of the SX8661Z, the way the pins are protected, if the pins are analog, digital, require pull up or pull down resistors and show control signals if these are available.

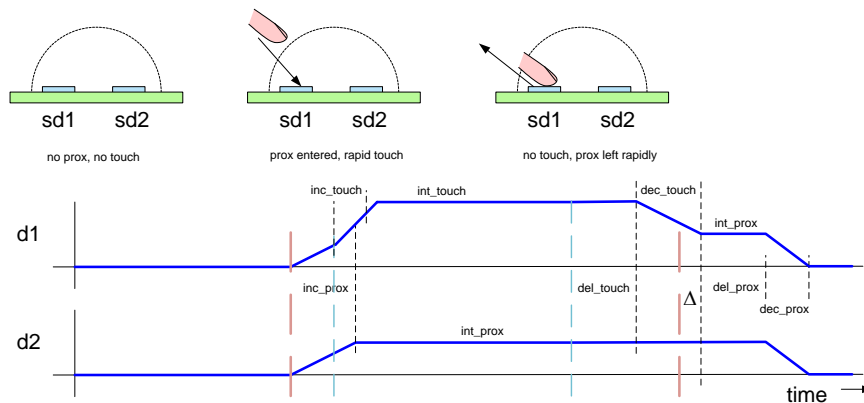
4.2 ASI pins**CAP0, CAP1,...,CAP7**

The capacitance sensor pins (CAP0, CAP1,...,CAP7) are connected directly to the ASI circuitry which converts the sensed capacitance into digital values.

The capacitance sensor pins which are not used should be left open.

The enabled CAP pins need be connected directly to the sensors without significant resistance (typical below some ohms, connection vias are allowed).

The capacitance sensor pins are protected to VANA and GROUND.

Figure 39 shows the simplified diagram of the CAP0, CAP1,...CAP7 pins.

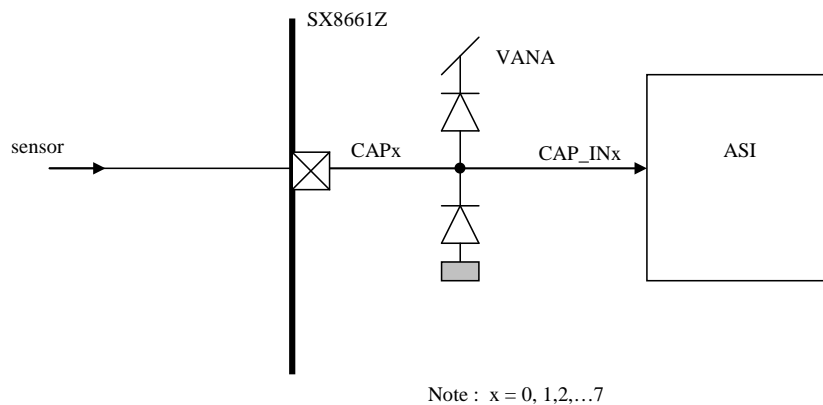

Figure 39 Simplified diagram of CAP0, CAP1,...,CAP7

CN, CP

The CN and the CP pins are connected to the ASI circuitry. A 1nF sampling capacitor between CP and CN needs to be placed as close as possible to the SX8661Z.

The CN and CP are protected to VANA and GROUND.

Figure 40 shows the simplified diagram of the CN and CP pins.

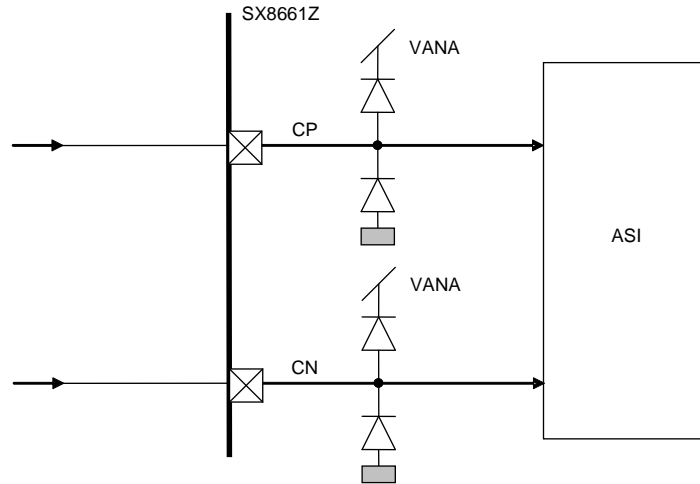

Figure 40 Simplified diagram of CN and CP

4.3 Host interface pins

The host interface consists of the interrupt pin INTB, a reset pin RESETB and the standard I2C pins: SCL and SDA.

INTB

The INTB pin is an open drain output that requires an external pull-up resistor (1..10 kOhm). The INTB pin is protected to VDD using dedicated devices. The INTB pin has diode protected to GROUND.

Figure 41 shows a simplified diagram of the INTB pin.

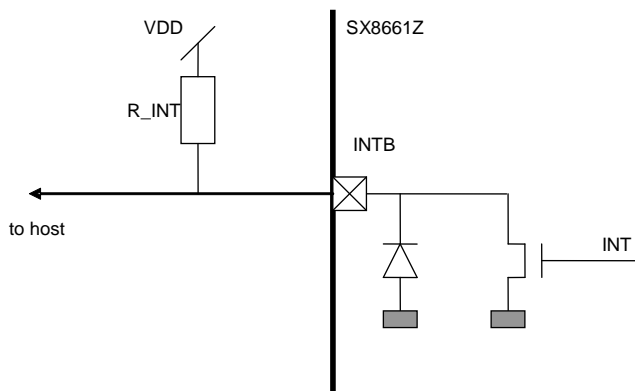

Figure 41 Simplified diagram of INTB

**SCL**

The SCL pin is a high impedance input pin. The SCL pin is protected to VDD, using dedicated devices, in order to conform to standard I2C slave specifications. The SCL pin has diode protected to GROUND. An external pull-up resistor (1..10 kOhm) is required on this pin.

Figure 42 shows the simplified diagram of the SCL pin.

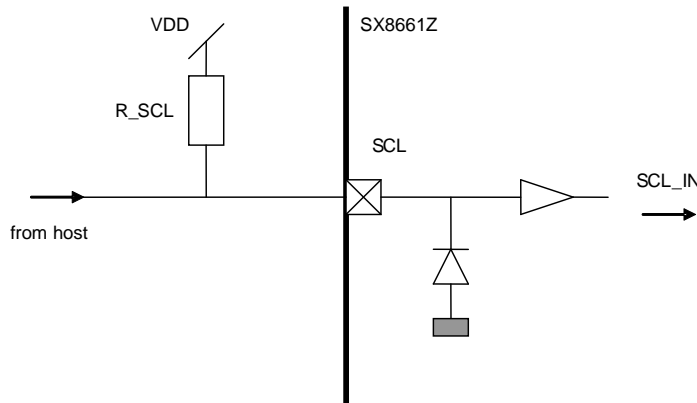

Figure 42 Simplified diagram of SCL

SDA

SDA is an IO pin that can be used as an open drain output pin with external pull-up resistor or as a high impedance input pin. The SDA IO pin is protected to VDD, using dedicated devices, in order to conform to standard I2C slave specifications. The SDA pin has diode protected to GROUND. An external pull-up resistor (1..10 kOhm) is required on this pin.

Figure 43 shows the simplified diagram of the SDA pin.

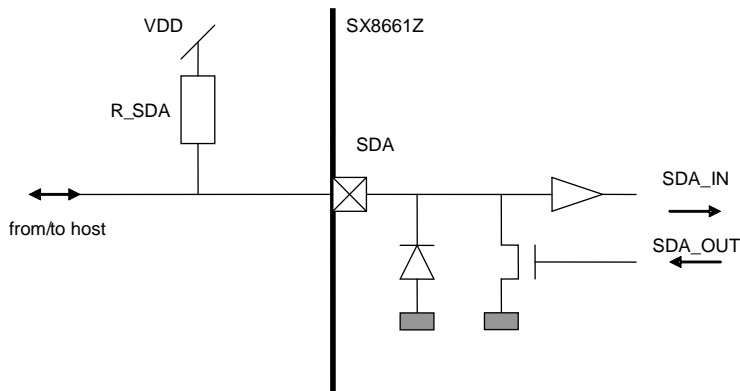

Figure 43 Simplified diagram of SDA



RESETB

The RESETB pin is a high impedance input pin. The RESETB pin is protected to VDD using dedicated devices. The RESETB pin has diode protected to GROUND.

Figure 44 shows the simplified diagram of the RESETB pin controlled by the host.

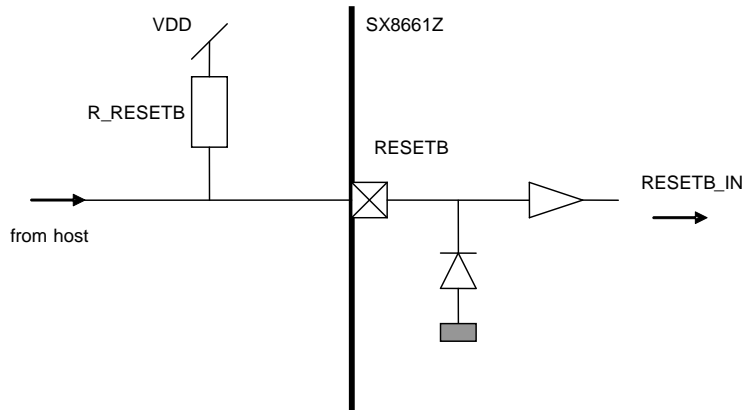

Figure 44 Simplified diagram of RESETB controlled by host

Figure 45 shows the RESETB without host control.

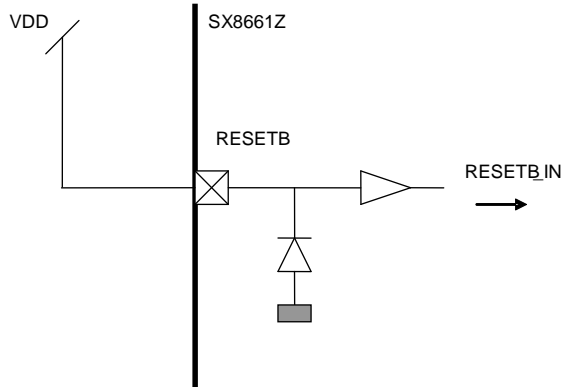

Figure 45 Simplified diagram of RESETB without host control



4.4 Power management pins

The power management pins consist of the Power, Ground and Regulator pins.

VDD

VDD is a power pin and is the main power supply for the SX8661Z.
VDD has protection to GROUND.

Figure 46 shows a simplified diagram of the VDD pin.

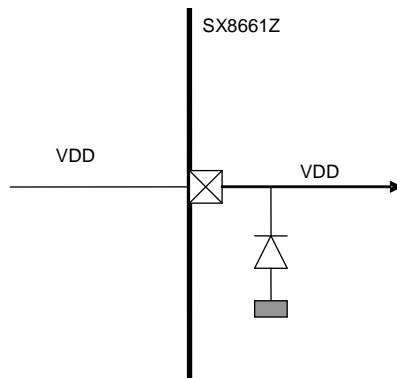

Figure 46 Simplified diagram of VDD

GND

The SX8661Z has four ground pins all named GND. These pins and the package center pad need to be connected to ground potential.

The GND has protection to VDD.

Figure 47 shows a simplified diagram of the GND pin.

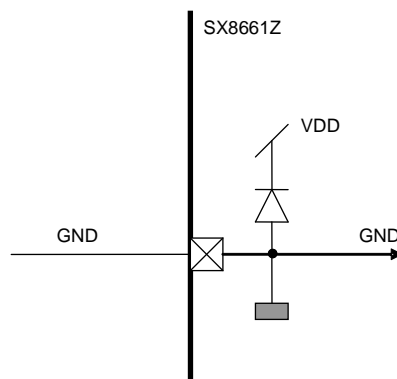

Figure 47 Simplified diagram of GND

**VANA, VDIG**

The SX8661Z has on-chip regulators for internal use (pins VANA and VDIG).

VANA and VDIG have protection to VDD and to GND.

The output of the regulators needs to be de-coupled with a small 100nF capacitor to ground.

Figure 48 shows a simplified diagram of the VANA and VDIG pin.

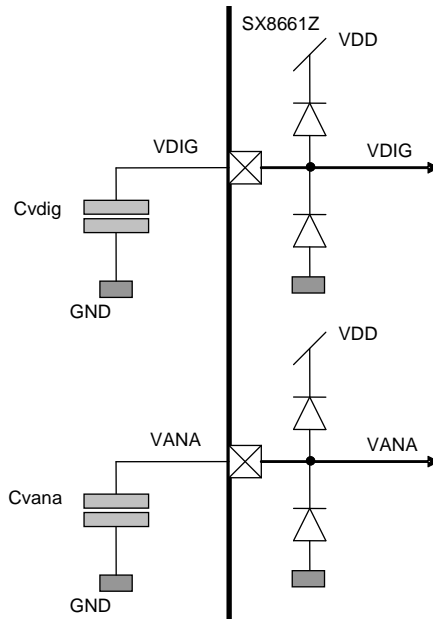

Figure 48 Simplified diagram of VANA and VDIG

4.5 General purpose IO pins

The SX8661Z has 8 General purpose input/output (GPIO) pins.

All the GPIO pins have protection to VDD and GND.

The GPIO pins can be configured as GPO, SPO or GPP.

Figure 49 shows a simplified diagram of the GPIO pins.

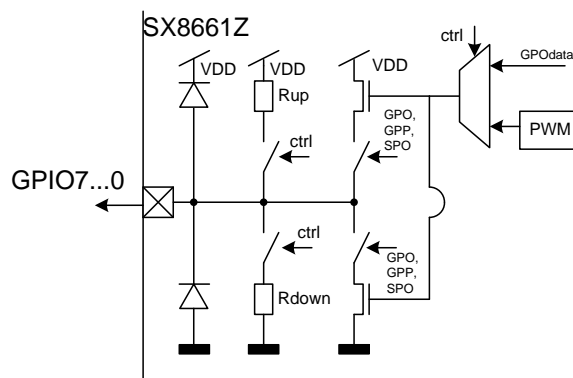

Figure 49 Simplified diagram of GPIO pins



5 DETAILED CONFIGURATION DESCRIPTIONS

5.1 Introduction

The SX8661Z configuration parameters are taken from the QSM or the NVM and loaded into the SPM as explained in the chapter 'functional description'.

This chapter describes the details of the configuration parameters of the SX8661Z.

The SPM is split by functionality into 5 configuration sections:

- General section: operating modes,
- Capacitive Sensors section: related to lower level capacitive sensing,
- Proximity: defining parameters related to proximity sensing
- Button: related to the conversion from sensor data towards button information,
- AOI: defining parameters for the AOI
- Buzzer: defining parameters for the AOI
- Mapping: related to mapping of button information towards GPIO pins,
- GPIO: related to the setup of the GPIO pins.

The total address space of the SPM and the NVM is 128 bytes, from address 0x00 to address 0x7F.

Two types of memory addresses, data are accessible to the user.

- 'application data': Application dependent data that need to be configured by the user.
- 'reserved': Data that need to be maintained by the user to the QSM default values (i.e. when NVM is burned).

The Table 11 and Table 12 resume the complete SPM address space and show the 'application data' and 'reserved' addresses.

The SX8661Z has the first NVM burned and hence powers-up with the NVM1 settings.

ADVANCED COMMUNICATIONS & SENSING DATASHEET

Address	Name	QSM / NVM1 values	Address	Name	QSM / NVM1 values		
0x00	Reserved	0xxx	0x20	ProxReporting	0x7F		
0x01	Reserved	0xxx	0x21		ProxIntensity	0x64	
0x02	Reserved	0x41	0x22	Button	BtnCfg	0x70	
0x03	Reserved	0xxx	0x23		BtnAvgThresh	0x50 / 0x4B	
0x04	General	I2CAddress	0x2B		0x24	BtnCompNegThresh	0xA0
0x05		ActiveScanPeriod	0x02		0x25	BtnCompNegCntMax	0x01
0x06		DozeScanPeriod	0x0D / 0x06		0x26	BtnHysteresis	0x0A / 0x0F
0x07		PassiveTimer	0x00		0x27	BtnStuckAtTimeout	0x00
0x08		Reserved	0x00		0x28	BtnStrongestHysteresis	0x80
0x09		CapModeMisc	0x04/0x00		0x29	BtnLongPressTimer	0x00
0x0A		Reserved	0x00		0x2A	Reserved	0xFF
0x0B		CapMode7_4	0x55		0x2B	Analog Output Interface (AOI)	AoiCfg
0x0C	CapMode3_0	0x57	0x2C	AoiBtnMapMsb	0x55 / 0xA9		
0x0D	CapSensitivity0_1	0x72 / 0x77	0x2D	AoiBtnMapLsb	0x55 / 0x54		
0x0E	CapSensitivity2_3	0x22 / 0x77	0x2E	AoiLevelBtn0	0xFF		
0x0F	CapSensitivity4_5	0x22 / 0x77	0x2F	AoiLevelBtn1	0x2E / 0x00		
0x10	CapSensitivity6_7	0x22 / 0x77	0x30	AoiLevelBtn2	0x45 / 0x3D		
0x11	Reserved	0x00	0x31	AoiLevelBtn3	0x5D / 0x7B		
0x12	Reserved	0x00	0x32	AoiLevelBtn4	0x74 / 0xB8		
0x13	CapThresh0	0xA0 / 0x7D	0x33	AoiLevelBtn5	0x8B / 0x3D		
0x14	CapThresh1	0xA0 / 0x7D	0x34	AoiLevelBtn6	0xA3 / 0x7B		
0x15	CapThresh2	0xA0 / 0x7D	0x35	AoiLevelBtn7	0xBA / 0xB8		
0x16	CapThresh3	0xA0 / 0x7D	0x36	AoiLevelIdle	0xFF		
0x17	CapThresh4	0xA0 / 0x7D	0x37	Buzzer	BuzzerCfg	0xA4	
0x18	CapThresh5	0xA0 / 0x7D	0x38		BuzzerFreqPhase1	0x40	
0x19	CapThresh6	0xA0 / 0x7D	0x39		BuzzerFreqPhase2	0x20	
0x1A	CapThresh7	0xA0 / 0x7D	0x3A	Reserved	0x00		
0x1B	CapPerComp	0x00	0x3B	Mapping	MapAutoLight0	0x07	
0x1C	Proximity	ProxIncDecTime	0x14 / 0x11		0x3C	MapAutoLight1	0x65
0x1D		ProxCfg	0xB0 / 0x10		0x3D	MapAutoLight2	0x43
0x1E		ProxDebounce	0x00		0x3E	MapAutoLight3	0x21 / 0x20
0x1F		ProxHysteresis	0x0A		0x3F	MapAutoLightGrp0Msb	0x00

Table 11 SPM address map: 0x00...0x3F

Note

- '0xxx': write protected data



Address	Name	QSM / NVM1 values
0x40	Mapping	MapAutoLightGrp0Lsb
0x41		MapAutoLightGrp1Msb
0x42		MapAutoLightGrp1Lsb
0x43	Gpio	GpioMode7_4
0x44		GpioMode3_0
0x45		GpioIntensityOn0
0x46		GpioIntensityOn1
0x47		GpioIntensityOn2
0x48		GpioIntensityOn3
0x49		GpioIntensityOn4
0x4A		GpioIntensityOn5
0x4B		GpioIntensityOn6
0x4C		GpioIntensityOn7
0x4D		GpioIntensityOff0
0x4E		GpioIntensityOff1
0x4F		GpioIntensityOff2
0x50		GpioIntensityOff3
0x51		GpioIntensityOff4
0x52		GpioIntensityOff5
0x53		GpioIntensityOff6
0x54		GpioIntensityOff7
0x55		Reserved
0x56		GpioOutPwrUp
0x57		GpioAutoLight
0x58		GpioPolarity
0x59		GpioFunction
0x5A		GpioIncFactor
0x5B		GpioDecFactor
0x5C		GpioIncTime7_6
0x5D		GpioIncTime5_4
0x5E	GpioIncTime3_2	
0x5F	GpioIncTime1_0	

Address	Name	QSM / NVM1 values
0x60	Gpio	GpioDecTime7_6
0x61		GpioDecTime5_4
0x62		GpioDecTime3_2
0x63		GpioDecTime1_0
0x64		GpioOffDelay7_6
0x65		GpioOffDelay5_4
0x66		GpioOffDelay3_2
0x67		GpioOffDelay1_0
0x68		GpioPullUpDown7_4
0x69		GpioPullUpDown3_0
0x6A		Reserved
0x6B		Reserved
0x6C		Reserved
0x6D		GpioFadingMode7_4
0x6E		GpioFadingMode3_0
0x6F	Reserved	
0x70	CapProxEnable	
0x71	Reserved	
0x72	Reserved	
0x73	Reserved	
0x74	Reserved	
0x75	Reserved	
0x76	Reserved	
0x77	Reserved	
0x78	Reserved	
0x79	Reserved	
0x7A	Reserved	
0x7B	Reserved	
0x7C	Reserved	
0x7D	Reserved	
0x7E	Reserved	
0x7F	SpmCrc ¹	

Table 12 SPM address map: 0x40...0x7F

Note¹

- SpmCrc: CRC depending on SPM content, updated in Active or Doze mode.

**5.2 General Parameters**

General Parameters			
Address	Name	Bits	Description
0x04	I2CAddress	7	Reserved (0x00).
		6:0	Defines the I2C address. The I2C address will be active after a reset.
0x05	ActiveScanPeriod	7:0	Defines Active Mode Scan Period (Figure 6). 0x00: Reserved 0x01: 15ms 0x02: 30ms ... 0xFF: 255 x 15ms
0x06	DozeScanPeriod	7:0	Defines Doze Mode Scan Period (Figure 6). 0x00: Reserved 0x01: 15ms ... 0x0D: 195ms ... 0xFF: 255 x 15ms
0x07	PassiveTimer	7:0	Defines Passive Timer on Button Information (Figure 7). 0x00: OFF 0x01: 1 second ... 0xFF: 255 seconds
0x08	Reserved	7:0	Reserved (0x00)

Table 13 General Parameters



5.3 Capacitive Sensors Parameters

Capacitive Sensors Parameters				
Address	Name	Bits	Description	
0x09	CapModeMisc	7:3	Reserved (0x00)	
		2:0	IndividualSensitivity Defines common sensitivity for all sensors or individual sensor sensitivity. 000: Common sensitivity settings (CapSensitivity0_1[7:4]) 100: Individual sensitivity settings (CapSensitivityx_x) Else : Reserved	
0x0A	Reserved	7:0	Reserved (0x00)	
0x0B	CapMode7_4	7:6	CAP7 Mode	
		5:4	CAP6 Mode	
		3:2	CAP5 Mode	
		1:0	CAP4 Mode	
0x0C	CapMode3_0	7:6	CAP3 Mode	
		5:4	CAP2 Mode	
		3:2	CAP1 Mode	
		1:0	CAP0 Mode	
0x0D	CapSensitivity0_1	7:4	CAP0 Sensitivity - Common Sensitivity	
		3:0	CAP1 Sensitivity	
	0x0E	CapSensitivity2_3	7:4	CAP2 Sensitivity
			3:0	CAP3 Sensitivity
	0x0F	CapSensitivity4_5	7:4	CAP4 Sensitivity
			3:0	CAP5 Sensitivity
	0x10	CapSensitivity6_7	7:4	CAP6 Sensitivity
			3:0	CAP7 Sensitivity
0x11	Reserved	7:0	Reserved (0x00)	
0x12	Reserved	7:0	Reserved (0x00)	
0x13	CapThresh0	7:0	CAP0 Touch Threshold	
0x14	CapThresh1	7:0	CAP1 Touch Threshold	
0x15	CapThresh2	7:0	CAP2 Touch Threshold	
0x16	CapThresh3	7:0	CAP3 Touch Threshold	
0x17	CapThresh4	7:0	CAP4 Touch Threshold	
0x18	CapThresh5	7:0	CAP5 Touch Threshold	
0x19	CapThresh6	7:0	CAP6 Touch Threshold	
0x1A	CapThresh7	7:0	CAP7 Touch Threshold	
0x1B	CapPerComp	7:4	Reserved (0x00)	
		3:0	Periodic Offset Compensation Defines the periodic offset compensation. 0x0: OFF 0x1: 1 second 0x2: 2 seconds ...	



Capacitive Sensors Parameters			
Address	Name	Bits	Description
			0x7: 7 seconds 0x8: 16 seconds 0x9: 18 seconds ... 0xE: 28 seconds 0xF: 60 seconds
0x70	CapProxEnable	7:0	Enables proximity sensing. 0x46: OFF 0x74: ON

*Table 14 Capacitive Sensors Parameters***CapModeMisc:**

By default the ASI is using an individual sensitivity for each CAP pin (with proximity sensor set to maximum sensitivity while touch sensors are set to a lower one). The individual sensitivity mode results in longer sensing periods than required in common sensitivity mode.

The ASI can use common sensitivity for all capacitive sensors in the case overlay material and sensors sizes are about equal. The register bits CapSensitivity0_1[7:4] determine the sensitivity for all sensors in common sensitivity mode.

CapMode7_4, CapMode3_0:

The CAP7 to CAP0 pins can be set as a button or disabled depending on the application. CAP0 can be used for proximity sensing (additionally set register CapProxEnable).

	minimum	maximum
Buttons	zero	seven

Table 15 Number of buttons (with CAP0 = proximity)

	minimum	maximum
Buttons	one	eight

Table 16 Number of buttons (with CAP0 = button or disabled)

Buttons and disabled CAP pins can be attributed freely (examples in Figure 50).

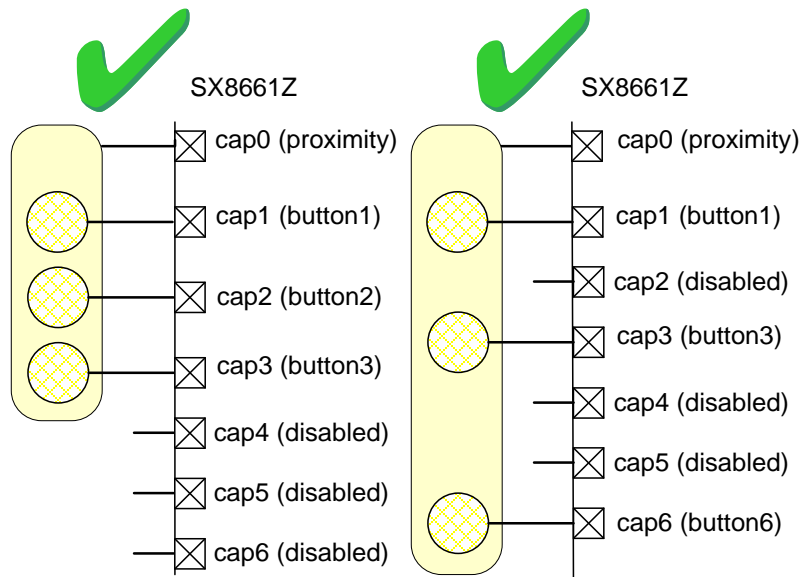
*Figure 50 Button examples*

CapSensitivity0_1, CapSensitivity2_3, CapSensitivity4_5, CapSensitivity6_7, CapProxEnable:

The sensitivity of the sensors can be set between 8 values. The higher the sensitivity is set the larger the value of the ticks will be.

The minimum sensitivity can be used for thin overlay materials and large sensors, while the maximum sensitivity is required for thicker overlay and smaller sensors or proximity sensing.

The required sensitivity needs to be determined during a product development phase. Too low sensitivity settings result in missing touches. Too high sensitivity settings will result in fault detection of fingers hovering above the touch sensors.

The sensitivity is identical for all sensors in common sensitivity mode using the bits CapSensitivity0_1[7:4] and can be set individually using register CapModeMisc[2:0].

The maximum number of ticks that can be obtained depends on the selected sensitivity and if proximity sensing is enabled. This is illustrated in Table 17.

Sensitivity	Approximate Maximum Tick Level (CapProxEnable = OFF)	Approximate Maximum Tick Level (CapProxEnable = ON)
0	1000	4000
1	2000	8000
2	3000	12000
3	4000	16000
4	5000	20000
5	6000	24000
6	7000	28000
7	8000	32000

Table 17 ASI Maximum Tick Levels

CapThresh0, CapThresh1, CapThresh2, CapThresh3, CapThresh4, CapThresh5, CapThresh6, CapThresh7:

For each CAP pin a threshold level can be set individually.
The threshold levels are used by the SX8661Z for making touch and release decisions.
The details are explained in the sections for buttons.

CapPerComp:

The SX8661Z offers a periodic offset compensation for applications which are subject to substantial environmental changes. The periodic offset compensation is done at a defined interval and only if buttons are released.

CapProxEnable:

The SX8661Z is intended to be used with proximity. This register is set by default to ON (0x74). In case proximity is not required then this register should be set to OFF (0x46) and CAP0 Mode should be set to button or disabled.

5.4 Proximity Parameters

Proximity Parameters			
Address	Name	Bits	Description
0x1C	ProxIncDecTime	7:4	Defines the time between each increment. 0x0: instantaneous 0x1: 0.5ms 0x2: 1ms ... 0xF: 7.5ms
		3:0	Defines the time between each decrement. 0x0: instantaneous 0x1: 0.5ms 0x2: 1ms ... 0x4: 2ms ... 0xF: 7.5ms
0x1D	ProxCfg	7:4	Defines the delay between release and start of fading out. 0x0: instantaneous 0x1: 200 ms 0x2: 400 ms 0x3: 600ms ... 0xA: 2s 0xB: 4s ... 0xF: 12s
		3:2	Reserved (0x00)
		1	Defines the fading increment factor. 0: intensity index incremented every increment time 1: intensity index incremented every 16 increment times
		0	Defines the fading decrement factor. 0: intensity index decremented every decrement time 1: intensity index decremented every 16 decrement times
0x1E	ProxDebounce	7:4	Reserved (0x00)
		3:2	Defines the number of samples at the scan period for determining proximity release. 00 : no debounce, use incoming sample 01 : 2 samples debounce 10 : 3 samples debounce 11 : 4 samples debounce
		1:0	Defines the number of samples at the scan period for determining proximity detection. 00 : no debounce, use incoming sample 01 : 2 samples debounce 10 : 3 samples debounce 11 : 4 samples debounce
0x1F	ProxHysteresis	7:0	Defines the proximity hysteresis corresponding to a percentage of the CAP0 threshold (defined in Table 14). 0x00: 0% 0x01: 1% ... 0x0A: 10% ... 0x64: 100%



Proximity Parameters			
Address	Name	Bits	Description
0x20	ProxReporting	7:0	Defines triple or dual mode reporting of proximity on the GPIOs. 0x00: dual mode 0x7F: triple mode
0x21	ProxIntensity	7:0	Defines the proximity ON intensity index. 0x00: 0 0x01: 1 ... 0x64: 100 ... 0xFF: 255

*Table 18 Proximity Parameters***ProxDebounce**

Defines the number of samples for determining proximity detection or out of proximity detection. This parameter allows to set the debouncer of the proximity differently from the buttons debouncer.

ProxHysteresis

Proximity is detected if the ticks are getting larger as the value defined by:
 $\text{CapThreshold0} + \text{CapThreshold0} * \text{hysteresis}$.

Out of proximity is detected if the ticks are getting smaller as the value defined by:
 $\text{CapThreshold0} - \text{CapThreshold0} * \text{hysteresis}$.

ProxReporting

Defines the reporting mode of proximity (either dual or triple) on the GPIOs.

ProxIntensity

Defines the proximity intensity index (applicable in triple reporting mode).

5.5 Button Parameters

Button Parameters			
Address	Name	Bits	Description
0x22	BtnCfg	7:6	Defines the buttons and proximity events reporting method on I2C, AOI, GPO, Buzzer (see Table 20 for details). 00: All 01: Single 10: Strongest 11: Reserved
		5:4	Defines the buttons interrupt (for all buttons and proximity). 00 : Interrupts masked 01 : Triggered on Touch 10 : Triggered on Release 11 : Triggered on Touch and Release
		3	Defines the number of samples at the scan period for determining a release of a button. 00 : no debounce, use incoming sample 01 : 2 samples debounce 10 : 3 samples debounce 11 : 4 samples debounce
		2:0	Defines the number of samples at the scan period for determining a touch of a button. 00 : no debounce, use incoming sample 01 : 2 samples debounce 10 : 3 samples debounce 11 : 4 samples debounce
0x23	BtnAvgThresh	7:0	Defines the positive threshold for disabling the processing filter averaging (one value for all buttons and proximity). If ticks are above the threshold, then the averaging is suspended. 0x00: 0 0x01: 4 ... 0x50: 320 ... 0xFF: 1020
0x24	BtnCompNegThresh	7:0	Defines the negative offset compensation threshold (one value for all buttons and proximity). 0x00: 0 0x01: 4 ... 0xA0: 640 ... 0xFF: 1020
0x25	BtnCompNegCntMax	7:0	Defines the number of ticks (below the negative offset compensation threshold) which will initiate an offset compensation (one value for all buttons and proximity). 0x00: reserved 0x01: 1 sample ... 0xFF: 255 samples
0x26	BtnHysteresis	7:0	Defines the button hysteresis corresponding to a percentage of the CAP thresholds (defined in Table 14). All buttons use the same hysteresis. 0x00: 0% 0x01: 1% ... 0x0A: 10% ...



Button Parameters			
Address	Name	Bits	Description
			0x64: 100%
0x27	BtnStuckAtTimeout	7:0	Defines the stuck at timeout for buttons and proximity. 0x00: OFF 0x01: 1 second ... 0xFF: 255 seconds
0x28	BtnStrongestHysteresis	7:0	Defines the hysteresis value for the strongest button filtering engine. This parameter is only valid when BtnCfg has been configured to “report the strongest touch”. The proximity sensor is excluded. The hysteresis element eliminates the jittery output due to environmental noise when two CAP sensors (configured as buttons) have values very close to each other. The BtnStrongestHysteresis defines how much bigger the signal of the second sensor needs to be compared to the strongest detected sensor, before the second sensor becomes the strongest detected touch. 0x00: 0 0x01: 1 ... 0x80: 128 ... 0xFF: 255
0x29	BtnLongPressTimer	7:0	Defines the long press button timeout on AOI pins (applicable in Single Reporting Mode). The proximity sensor does not trigger the timer. 0x00: OFF 0x01: 1 second ... 0xFF: 255 seconds

Table 19 Button Parameters

The buttons and the proximity sensor operate in a similar way although some parameters can be set uniquely for buttons or the proximity sensor only (according the previous tables describing the button and proximity parameters).

A reliable button operation requires a coherent setting of the registers.

Figure 51 shows an example of a touch and a release. The ticks will vary slightly around the zero idle state.

When the touch occurs the ticks will rise sharply. At the release of the button the ticks will go down rapidly and converge to the idle zero value.

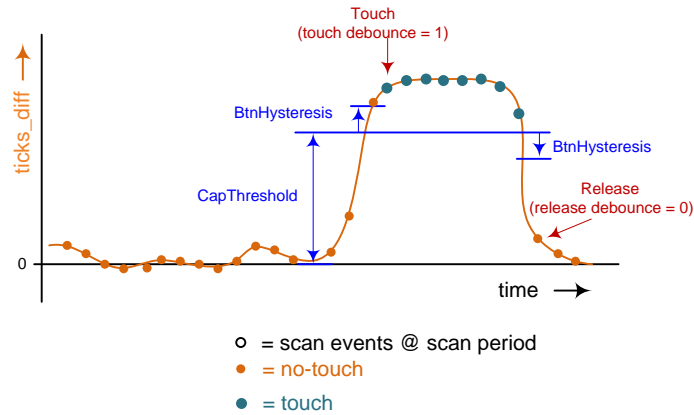
*Figure 51 Touch and Release Example*

As soon as the ticks become larger than the CAP thresholds (see registers of the previous section) plus the hysteresis (defined in register BtnHysteresis) the debounce counter starts.

In the example of Figure 51 the touch is validated after 2 ticks (BtnCfg [2:0] = 1).

The release is detected immediately (BtnCfg [3] = 0) at the first tick which is below the threshold minus the hysteresis.

BtnCfg

The SX8661Z button and proximity interface has three modes of operation:

- **Report All:** reports all touches of multiple fingers and proximity detection.
- **Report Single:** reports only a single touch and/or proximity. Subsequent touches are ignored until the first touch is released. On the AOI proximity is implicit in case of a button touch.
- **Report Strongest:** reports the strongest touch. When the signal from another sensor rises above the first sensor's signal, the second sensor is then reported instead. On the AOI proximity is implicit in case of a button touch.

Table 20 resumes the relation of reporting modes and information on the interfaces.

Reporting Mode	I2C	AOI	GPIOs (LEDs)	Buzzer
All	Buttons and Proximity	Forced to Idle	Buttons and Proximity	Button
Single	Proximity or 1 Button and Proximity	Idle or 1 Button or Proximity	Buttons and Proximity	Button
Strongest	Proximity or 1 Button and Proximity	Idle or 1 Button or Proximity	Buttons and Proximity	Button

Table 20 Reporting modes

The user can select to have the interrupt signal (INTB) on touching a button (proximity detected), releasing a button (out of proximity) or both.

In noisy environments it may be required to debounce the touch and release detection decision.



In case the debounce is enabled the SX8661Z will count up to the number of debounce samples BtnCfg [1:0], BtnCfg [3:2] before taking a touch or release decision. The sample period is identical to the scan period.

BtnAvgPosThresh

Small environmental and system noise cause the ticks to vary slowly around the zero idle mode value. In case the ticks get slightly positive this is considered as normal operation. Very large positive tick values indicate a valid touch. The averaging filter is disabled as soon as the average reaches the value defined by BtnAvgPosThresh. This mechanism avoids that a valid touch will be averaged and finally the tick difference becomes zero.

In case three or more sensors reach the BtnAvgPosThresh value simultaneously then the SX8661Z will start an offset compensation procedure.

Small environmental and system noise cause the ticks to vary slowly around the zero idle mode value. In case the ticks get slightly negative this is considered as normal operation. However large negative values will trigger an offset compensation phase and a new set of DCVs will be obtained. The decision to trigger a compensation phase based on negative ticks is determined by the value in the register BtnCompNegThresh and by the number of ticks below the negative thresholds defined in register BtnCompNegCntMax. An example is shown in Figure 52.

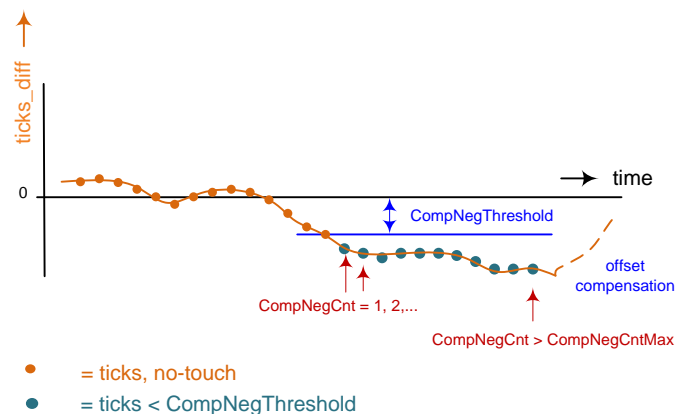

Figure 52 Negative Ticks Offset Compensation Trigger

BtnCompNegThresh

Small negative ticks are considered as normal operation and will occur very often. Larger negative ticks however need to be avoided and a convenient method is to trigger an offset compensation phase. The new set of DCV will assure the idle ticks will be close to zero again. A trade-off has to be found for the value of this register. A negative threshold too close to zero will trigger a compensation phase very often. A very negative threshold will never trigger.

BtnCompNegCntMax

As soon as the ticks get smaller than the Negative Threshold the Negative Counter starts to count. If the counter goes beyond the Negative Counter Max then the offset compensation phase is triggered. The recommended value for this register is '1' which means that the offset compensation starts on the first tick below the negative threshold.

BtnHysteresis

The hysteresis percentage is identical for all buttons. A touch is detected if the ticks are getting larger as the value defined by:



CapThreshold + CapThreshold * hysteresis.

A release is detected if the ticks are getting smaller as the value defined by:
CapThreshold - CapThreshold * hysteresis.

BtnStuckAtTimeout

The stuckat timer can avoid sticky buttons.

If the stuckat timer is set to one second then the touch of a finger will last only for one second and then a compensation will be performed and button hence considered released, even if the finger remains on the button for a longer time. After the actual finger release the button can be touched again and will be reported as usual.

In case the stuckat timer is not required it can be set to zero.

BtnStrongestHysteresis

This parameter defines the hysteresis value for the adjacent button filtering engine. This parameter is only valid when BtnCfg has been configured to report the strongest touch.

When the SX8661Z device has been configured to report the strongest touch, a situation may arise where the CAP signals of two sensors are of approximately equal value. Environmental noise can cause the signals of these two sensors to fluctuate as shown in Figure 55 (b).

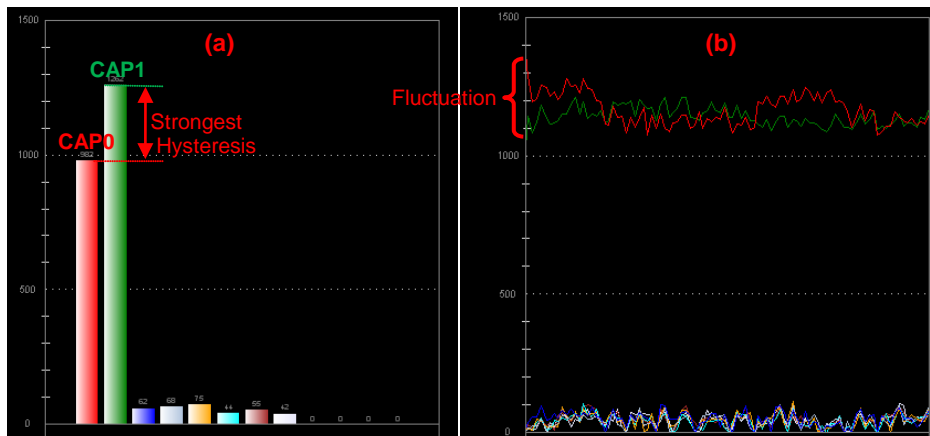

Figure 53 Strongest touch and Hysteresis

As a result of that, the output of the SX8661Z device would also change very quickly as each of the two sensors becomes the sensor with the strongest touch value. To eliminate this jitter, the SX8661Z device adds a hysteresis element to the calculation of the strongest touch sensor. In that respect, the strongest CAP sensor is calculated as the sensor whose value is greater than the second detected strongest CAP sensor by the Strongest hysteresis amount.

For example, as shown in Figure 55, the strongest CAP sensor is initially CAP0 (Figure 55 (b)). CAP1 becomes the strongest detected touch only if at some point in time the following holds true:

$$\text{CAP1 signal} = \text{CAP0 signal} + \text{StrongestHysteresis}$$

Similarly, if CAP2 is now also touched, it will only become the strongest detected touch if:

$$\text{CAP2 signal} = \text{CAP1 signal} + \text{StrongestHysteresis}.$$

BtnLongPressTimer



This timer defines the time in seconds that the AOI will put out a voltage level corresponding to the button touched. The timer is applicable in the Single Reporting Mode. After the timer expires the AOI will return to the idle level even if the button is still touched.

The I2C status and GPO are not affected by this timer (i.e. they will be updated when the button is actually released).

**5.6 Analog Output Interface Parameters**

Analog Output Interface (AOI) Parameters			
Address	Name	Bits	Description
0x2B	AoiCfg	7:6	Reserved (0x00).
		5:4	Defines AoiLevelDuringBuzzer (same for A&B). 0x00: AOI button level 0x01: AOI Idle level 0x10: min level (0V) 0x11: max level(VDD)
		3	Defines Aoi pwm period (same for A&B). 0: 0xFF (255) 1: 0x3F (63)
		2:0	Reserved (0x01)
0x2C	AoiBtnMapMsb	7:0	Button[7]
			Button[6]
			Button[5]
			Button[4]
0x2D	AoiBtnMapLsb	7:0	Button[3]
			Button[2]
			Button[1]
			Button[0] or Proximity
0x2E	AoiLevelBtn0	7:0	Defines the level index (cf Table 7) for Buttons, Idle or Proximity (for CAP0) The level index should be smaller or equal to Aoi pwm period as defined in AoiCfg[3]. 0x00: 0 0x01: 1 ... 0xFF: 255
0x2F	AoiLevelBtn1	7:0	
0x30	AoiLevelBtn2	7:0	
0x31	AoiLevelBtn3	7:0	
0x32	AoiLevelBtn4	7:0	
0x33	AoiLevelBtn5	7:0	
0x34	AoiLevelBtn6	7:0	
0x35	AoiLevelBtn7	7:0	
0x36	AoiLevelIdle	7:0	

Table 21 AOI Parameters

AoiBtnMap

This register is used to map the available buttons to SWI-A, AOI-B or both. For example, to map buttons 0 to 3 and buttons 4 to 7 on AOI-B, write the following value to the AoiPwmBtnMap register

AoiCfg = 0xAA55;

AoiLevelBtn0, AoiLevelBtn1, AoiLevelBtn2, AoiLevelBtn3, AoiLevelBtn4, AoiLevelBtn5, AoiLevelBtn6,
AoiLevelBtn7, AoiLevelIdle



These registers define the level that will be output on AOI-A or AOI-B (depending on button mapping) when the corresponding button is touched or when the corresponding state is active or idle. The duty cycle is defined as a number of steps.

The mean voltage of a PWM signal is given by:

$$\text{Mean voltage} \approx (\text{AoiLevelBtnx} / \text{AoiPwmPeriod}) * \text{Maximum Voltage (VDD)}$$

or:

$$\text{AoiLevelBtnx} \approx (\text{Mean voltage} / \text{Maximum Voltage (VDD)}) * \text{AoiPwmPeriod}$$

AoiPwmPeriod is 255 or 63.

Example:

When button 0 is touched the desired AOI voltage is 0.30 Volts.

To calculate the AoiLevelBtnx is as follows (with AoiPwmPeriod=255):

Assuming a 3.3V VDD:

$$\begin{aligned} \text{AoiLevelBtnx} &\approx (\text{Mean voltage} / \text{Maximum Voltage (VDD)}) * \text{AoiPwmPeriod} \\ &\approx (0.3/3.3) * 255 \approx 23 \text{ decimal} \end{aligned}$$

Write 0x17 in the register AoiBtn0DutyCycle.

**5.7 Buzzer Parameters**

Buzzer Parameters			
Address	Name	Bits	Description
0x37	BuzzerCfg	7:6	Defines the phase 1 duration. 0x00: ~ 5ms 0x01: ~ 10ms 0x02: ~ 15ms 0x03: ~ 30ms
		5:4	Defines the phase 2 duration. 0x00: ~ 5ms 0x01: ~ 10ms 0x02: ~ 15ms 0x03: ~ 30ms
		3	Defines the buzzer idle level (BuzzerLevelIdle). 0x0: min level (0V) 0x1: max level (VDD)
		2:0	Defines the buzzer pwm prescaler value.
0x38	BuzzerFreqPhase1	7:0	Defines the frequency for the first phase of the buzzer. $\text{freq} \approx 4\text{MHz} / (2^{\text{prescaler}} * \text{BuzzerFreqPhase1})$
0x39	BuzzerFreqPhase2	7:0	Defines the frequency for the second phase of the buzzer. $\text{freq} \approx 4\text{MHz} / (2^{\text{prescaler}} * \text{BuzzerFreqPhase2})$
0x3A	Reserved	7:0	Reserved (0x00)

Table 22 Buzzer Parameters

The buzzer parameters are described in section 3.6.

**5.8 Mapping Parameters**

Mapping Parameters				
Address	Name	Bits	Description	
0x3B	MapAutoLight0	7:4	GPIO[7]	Defines the mapping between GPOs (with Autolight ON) and sensor events. 0x00: Btn0 or Proximity 0x01: Btn1 ... 0x07: Btn7 0x08...0x0B: Reserved 0x0C: Group0 as defined by MapAutoLightGrp0 0x0D: Group1 as defined by MapAutoLightGrp1 0x0E: Reserved 0x0F: Reserved
		3:0	GPIO[6]	
0x3C	MapAutoLight1	7:4	GPIO[5]	Several GPOs can be mapped to the same sensor event and will be controlled simultaneously.
		3:0	GPIO[4]	
0x3D	MapAutoLight2	7:4	GPIO[3]	
		3:0	GPIO[2]	
0x3E	MapAutoLight3	7:4	GPIO[1]	
		3:0	GPIO[0]	
0x3F	MapAutoLightGrp0Msb	7:0	Reserved (0x00)	
0x40	MapAutoLightGrp0Lsb	7	Btn7	Defines Group0 sensor events: 0: OFF 1: ON If any of the enabled sensor events occurs the Group0 event will occur as well. All sensors events within the group can be independently set.
		6	Btn6	
		5	Btn5	
		4	Btn4	
		3	Btn3	
		2	Btn2	
		1	Btn1	
		0	Btn0 or Proximity	
0x41	MapAutoLightGrp1Msb	7:0	Reserved (0x00)	
0x42	MapAutoLightGrp1Lsb	7	Btn7	Defines Group1 sensor events: 0: OFF 1: ON If any of the enabled sensor events occurs the Group0 event will occur as well. All sensors events within the group can be independently set.
		6	Btn6	
		5	Btn5	
		4	Btn4	
		3	Btn3	
		2	Btn2	
		1	Btn1	
		0	Btn0 or Proximity	

Table 23 Mapping Parameters

MapAutoLight0, MapAutoLight1, MapAutoLight2, MapAutoLight3
MapAutoLightGrp0Msb, MapAutoLightGrp0Lsb, MapAutoLightGrp1Msb, MapAutoLightGrp1Lsb

These registers define the mapping between the GPO pins (with Autolight ON) and the sensor information which will control its ON/OFF state.

The mapping can be done to a specific sensor event but also on groups (in this case any sensor event in the group will control the GPO).



Table 24 defines for each selectable sensor event, which action will trigger corresponding GPO to switch ON or OFF.

MapAutoLight	GPO ON	GPO OFF
BtnX	Touch	Release

Table 24 Autolight Mapping, Sensor Information

Examples:

- If GPO[0] should change state accordingly to Btn4 then MapAutoLight3[3:0] should be set to 0x04.
- If GPO[0] should change state accordingly to Btn0 or Btn1 then Group0 can be used as following:
 - MapAutoLight3[3:0] should be set to 0x0C (i.e. Group0).
 - MapAutoLightGrp0 should be set to 0x0003 (i.e. Btn0 or Btn1)

**5.9 GPIO Parameters**

GPIO Parameters				
Address	Name	Bits	Description	
0x43	GpioMode7_4	7:6	GPIO[7] Mode	Defines the GPIO mode. 00: GPO 01: GPP 10: Reserved 11: SPO: AOI-A for GPIO[7], AOI-B for GPIO[6], Buzzer for GPIO[5], Reserved for GPIO[4..0]
		5:4	GPIO[6] Mode	
		3:2	GPIO[5] Mode	
		1:0	GPIO[4] Mode	
0x44	GpioMode3_0	7:6	GPIO[3] Mode	
		5:4	GPIO[2] Mode	
		3:2	GPIO[1] Mode	
		1:0	GPIO[0] Mode	
0x45	GpioIntensityOn0	7:0	Defines the ON intensity index.	
0x46	GpioIntensityOn1	7:0	0x00: 0 0x01: 1	
0x47	GpioIntensityOn2	7:0	...	
0x48	GpioIntensityOn3	7:0	0xFF: 255	
0x49	GpioIntensityOn4	7:0		
0x4A	GpioIntensityOn5	7:0		
0x4B	GpioIntensityOn6	7:0		
0x4C	GpioIntensityOn7	7:0		
0x4D	GpioIntensityOff0	7:0	Defines the OFF intensity index.	
0x4E	GpioIntensityOff1	7:0	0x00: 0 0x01: 1	
0x4F	GpioIntensityOff2	7:0	...	
0x50	GpioIntensityOff3	7:0	0xFF: 255	
0x51	GpioIntensityOff4	7:0		
0x52	GpioIntensityOff5	7:0		
0x53	GpioIntensityOff6	7:0		
0x54	GpioIntensityOff7	7:0		
0x56	GpioOutPwrUp	7:0	Defines the values of GPO and GPP pins after power up i.e. default values of I2C parameters GpoCtrl and GppIntensity respectively. Bits corresponding to GPO pins with Autolight ON should be left to 0. Before being actually initialized GPIOs are set as inputs with pull up. 0: OFF(GPO) / IntensityOff (GPP) 1: ON (GPO) / IntensityOn (GPP)	
0x57	GpioAutoLight	7:0	Enables Autolight in GPO mode. 0 : OFF 1 : ON	
0x58	GpioPolarity	7:0	Defines the polarity of the GPO and GPP pins. SPO pins require Normal Polarity. 0: Inverted	

**ADVANCED COMMUNICATIONS & SENSING****DATASHEET**

GPIO Parameters					
Address	Name	Bits	Description		
			1: Normal		
0x59	GpioFunction	7:0	Defines the intensity index vs PWM pulse width function. 0: Logarithmic 1: Linear		
0x5A	GpioIncFactor	7:0	Defines the fading increment factor. 0: intensity index incremented every increment time 1: intensity index incremented every 16 increment times		
0x5B	GpioDecFactor	7:0	Defines the fading decrement factor. 0: intensity index decremented every decrement time 1: intensity index decremented every 16 decrement times		
0x5C	GpioIncTime7_6	7:4	GPIO[7] Fading Increment Time	Defines the fading increment time. 0x0: OFF 0x1: 0.5ms 0x2: 1ms ... 0xF: 7.5ms The total fading in time will be: $GpioIncTime * GpioIncFactor * (GpioIntensityOn - GpioIntensityOff)$	
		3:0	GPIO[6] Fading Increment Time		
0x5D	GpioIncTime5_4	7:4	GPIO[5] Fading Increment Time		
		3:0	GPIO[4] Fading Increment Time		
0x5E	GpioIncTime3_2	7:4	GPIO[3] Fading Increment Time		
		3:0	GPIO[2] Fading Increment Time		
0x5F	GpioIncTime1_0	7:4	GPIO[1] Fading Increment Time		
		3:0	GPIO[0] Fading Increment Time		
0x60	GpioDecTime7_6	7:4	GPIO[7] Fading Decrement Time		Defines the fading decrement time. 0x0: OFF 0x1: 0.5ms 0x2: 1ms ... 0x4: 2.0ms ... 0xF: 7.5ms The total fading out time will be: $GpioDecTime * GpioDecFactor * (GpioIntensityOn - GpioIntensityOff)$
		3:0	GPIO[6] Fading Decrement Time		
0x61	GpioDecTime5_4	7:4	GPIO[5] Fading Decrement Time		
		3:0	GPIO[4] Fading Decrement Time		
0x62	GpioDecTime3_2	7:4	GPIO[3] Fading Decrement Time		
		3:0	GPIO[2] Fading Decrement Time		
0x63	GpioDecTime1_0	7:4	GPIO[1] Fading Decrement Time		
		3:0	GPIO[0] Fading Decrement Time		
0x64	GpioOffDelay7_6	7:4	GPIO[7] OFF Delay	Single Fading Mode Defines the delay between release and start of fading out. 0x0: instantaneous 0x1: 200 ms 0x2: 400 ms 0x3: 600ms ... 0xA: 2s 0xB: 4s ... 0xF: 12s	
		3:0	GPIO[6] OFF Delay		
0x65	GpioOffDelay5_4	7:4	GPIO[5] OFF Delay		
		3:0	GPIO[4] OFF Delay		
0x66	GpioOffDelay3_2	7:4	GPIO[3] OFF Delay		
		3:0	GPIO[2] OFF Delay		
0x67	GpioOffDelay1_0	7:4	GPIO[1] OFF Delay		
		3:0	GPIO[0] OFF Delay		

**ADVANCED COMMUNICATIONS & SENSING****DATASHEET**

GPIO Parameters				
Address	Name	Bits	Description	
0x68	GpioPullUpDown7_4	7:6	GPIO[7] Pullup/down	Enables pullup/down resistors for GPIO pins. 00 : None 01 : Pullup 10 : Pulldown 11 : Reserved
		5:4	GPIO[6] Pullup/down	
		3:2	GPIO[5] Pullup/down	
		1:0	GPIO[4] Pullup/down	
0x69	GpioPullUpDown3_0	7:6	GPIO[3] Pullup/down	
		5:4	GPIO[2] Pullup/down	
		3:2	GPIO[1] Pullup/down	
		1:0	GPIO[0] Pullup/down	
0x6A	Reserved	7:0	Reserved (0x00)	
0x6B	Reserved	7:0	Reserved (0x00)	
0x6C	Reserved	7:0	Reserved (0x00)	
0x6D	GpioFadingMode7_4	7:6	Fading mode for GPIO[7]	Defines the Fading mode for GPO[7:0]. 00: Single Fading Mode 01: Continuous Fading Mode 10: Reserved 11: Reserved
		5:4	Fading mode for GPIO[6]	
		3:2	Fading mode for GPIO[5]	
		1:0	Fading mode for GPIO[4]	
0x6E	GpioFadingMode3_0	7:6	Fading mode for GPIO[3]	The fading modes are expected to be defined at power up by the QSM or NVM. In case the fading modes need to be changed after power up this can be done when the GPOs are all OFF.
		5:4	Fading mode for GPIO[2]	
		3:2	Fading mode for GPIO[1]	
		1:0	Fading mode for GPIO[0]	



Table 25 resumes the applicable SPM and I2C parameters for each GPIO mode.

		GPP	GPO	SPO
SPM	GpioMode	X	X	X ⁵
	GpioOutPwrUp	X ¹	X ^{2,3}	
	GpioAutolight		X	
	GpioPolarity	X	X	
	GpioIntensityOn	X ¹	X	
	GpioIntensityOff	X ¹	X	
	GpioFunction	X	X	
	GpioIncFactor		X	
	GpioDecFactor		X	
	GpioIncTime		X	
	GpioDecTime		X	
	GpioOffDelay		X	
	GpioPullUpDown			
I2C	IrqSrc[4]			
	GpoCtrl		X ⁴	
	GppPinId	X		
	GppIntensity	X ¹		

¹ At power up, GppIntensity of each GPP pin is initialized with GpioIntensityOn or GpioIntensityOff depending on GpioOutPwrUp corresponding bits value.

² Only if Autolight is OFF, else must be left to 0 (default value)

³ GpioOutPwrUp must be set to OFF in Continuous Fading Mode (with Autolight OFF)

⁴ Only if Autolight is OFF, else ignored

⁵ In SPO mode assure the following settings: GpioOutPwrUp=OFF, GpioAutoLight=ON, GpioPolarity=Normal, GpioFunction=Linear

Table 25 Applicable SPM/I2C Parameters vs. GPIO Mode

**6 I2C INTERFACE**

The I2C implemented on the SX8661Z is compliant with:

- standard (100kb/s), fast mode (400kb/s)
- slave mode
- 7 bit address (default 0x2B). The default address can be changed in the NVM at address 0x04.

The host can use the I2C to read and write data at any time. The effective changes will be applied at the next processing phase (section 3.2).

Three types of registers are considered:

- status (read). These registers give information about the status of the capacitive buttons, GPIOs, operation modes etc...
- control (read/write). These registers control the soft reset, operating modes, GPIOs and offset compensation.
- SPM gateway (read/write). These registers are used for the communication between host and the SPM. The SPM gateway communication is done typically at power up and is not supposed to be changed when the application is running. The SPM needs to be re-stored each time the SX8661Z is powered down. The SPM can be stored permanently in the NVM memory of the SX8661Z. The SPM gateway communication over the I2C at power up is then not required.

The I2C will be able to read and write from a start address and then perform read or writes sequentially, and the address increments automatically.

The supported I2C access formats are described in the next sections.

6.1 I2C Write

The format of the I2C write is given in Figure 54.

After the start condition [S], the slave address (SA) is sent, followed by an eighth bit ('0') indicating a Write. The SX8661Z then acknowledges [A] that it is being addressed, and the master sends an 8 bit Data Byte consisting of the SX8661Z Register Address (RA). The slave acknowledges [A] and the master sends the appropriate 8 bit Data Byte (WD0). Again the slave acknowledges [A]. In case the master needs to write more data, a succeeding 8 bit Data Byte will follow (WD1), acknowledged by the slave [A]. This sequence will be repeated until the master terminates the transfer with the Stop condition [P].

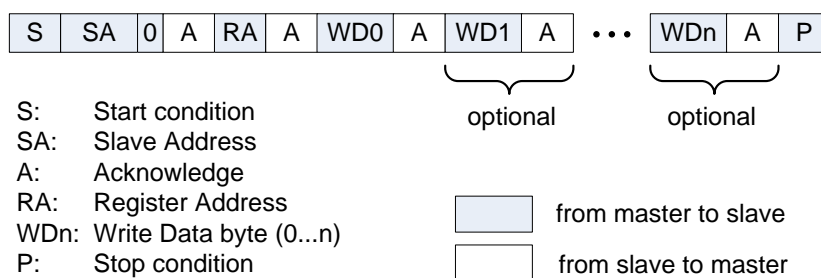

Figure 54 I2C write

The register address is incremented automatically when successive register data (WD1...WDn) is supplied by the master.

**6.2 I2C read**

The format of the I2C read is given in Figure 55.

After the start condition [S], the slave address (SA) is sent, followed by an eighth bit ('0') indicating a Write. The SX8661Z then acknowledges [A] that it is being addressed, and the master responds with an 8 bit data consisting of the Register Address (RA). The slave acknowledges [A] and the master sends the Repeated Start Condition [Sr]. Once again, the slave address (SA) is sent, followed by an eighth bit ('1') indicating a Read.

The SX8661Z responds with acknowledge [A] and the Read Data byte (RD0). If the master needs to read more data it will acknowledge [A] and the SX8661Z will send the next read byte (RD1). This sequence can be repeated until the master terminates with a NACK [N] followed by a stop [P].

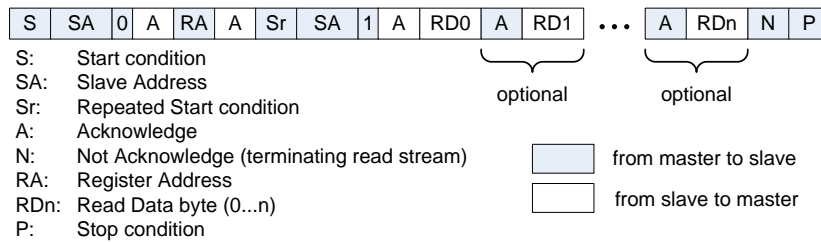

Figure 55 I2C read

**6.3 I2C Registers Overview**

Address	Name	R/W	Description
0x00	IrqSrc	read	Interrupt Source
0x01	Reserved		
0x02	CapStat	read	Button Status
0x03	Reserved		
0x04	Reserved		
0x05	Reserved		
0x06	Reserved		
0x07	Reserved		
0x08	SpmStat	read	SPM Status
0x09	CompOpMode	read/write	Compensation and Operating Mode
0x0A	GpoCtrl	read/write	GPO Control
0x0B	GppPinId	read/write	GPP Pin Selection
0x0C	GppIntensity	read/write	GPP Intensity
0x0D	SpmCfg	read/write	SPM Configuration
0x0E	SpmBaseAddr	read/write	SPM Base Address
0x0F	Reserved		
0xAC	SpmKeyMsb	read/write	SPM Key MSB
0xAD	SpmkeyLsb	read/write	SPM Key LSB
0xB1	SoftReset	read/write	Software Reset

Table 26 *I2C Registers Overview*

**6.4 Status Registers**

Address	Name	Bits	Description
0x00	IrqSrc	7	Reserved
		6	NVM burn interrupt flag
		5	SPM write interrupt flag
		4	Reserved
		3	Reserved
		2	Buttons/Proximity interrupt flag
		1	Compensation interrupt flag
		0	Operating Mode interrupt flag

Table 27 Interrupt Source

The delay between the actual event and the flags indicating the interrupt source may be one scan period.

IrqSrc[6] is set once NVM burn procedure is completed.

IrqSrc[5] is set once SPM write is effective.

IrqSrc[2] is set if a Button/Proximity event occurred (touch or release if enabled). CapStatLsb show the detailed status of the Buttons.

IrqSrc[1] is set once compensation procedure is completed either through automatic trigger or via host request.

IrqSrc[0] is set when actually entering Active or Doze mode via host request. CompOpmode shows the current operation mode.



Address	Name	Bits	Description
0x02	CapStat	7	Status button 7
		6	Status button 6
		5	Status button 5
		4	Status button 4
		3	Status button 3
		2	Status button 2
		1	Status button 1
		0	Status button 0

Status of individual buttons
0: Released (default)
1: Touched

Table 28 I2C Cap status

Address	Name	Bits	Description
0x08	SpmStat	7:4	reserved
		3	NvmValid Indicates if the current NVM is valid. 0: No – QSM is used 1: Yes – NVM is used
		2:0	NvmCount Indicates the number of times NVM has been burned: 0: None – QSM is used (default) 1: Once – NVM is used if NvmValid = 1, else QSM. 2: Twice – NVM is used if NvmValid = 1, else QSM. 3: Three times – NVM is used if NvmValid = 1, else QSM. 4: More than three times – QSM is used

Table 29 I2C SPM status

**6.5 Control Registers**

Address	Name	Bits	Description
0x09	CompOpMode	7:3	Reserved*, write only '00000'
		2	Compensation Indicates/triggers compensation procedure 0: Compensation completed (default) 1: read -> compensation running ; write -> trigger compensation
		1:0	Operating Mode Indicates/programs** operating mode 00: Active mode (default) 01: Doze mode 10: Sleep mode 11: Reserved

* The reading of these reserved bits will return varying values.

** After the operating mode change (Active/Doze) the host should wait for INTB or 300ms before performing any I2C read access.

Table 30 I2C compensation, operation modes

Address	Name	Bits	Description
0x0A	GpoCtrl	7:0	GpoCtrl[7:0] Triggers ON/OFF state of GPOs when Autolight is OFF 0: OFF (i.e. go to IntensityOff) 1: ON (i.e. go to IntensityOn) Default is set by SPM parameter GpioOutPwrUp Bits of non-GPO pins are ignored.

Table 31 I2C GPO Control



Address	Name	Bits	Description
0x0B	GppPinId	7:3	Reserved, write only '00000'
		2:0	GPP Pin Identifier Defines the GPP pin to which the GppIntensity is assigned for the following read/write operations 0x0 = GPP0 (default) 0x1 = GPP1 ... 0x7 = GPP7 GPPx refers to pin GPIOx configured as GPP

Table 32 I2C GPP Pin Identifier

Address	Name	Bits	Description
0x0C	GppIntensity	7:0	Defines the intensity index of the GPP pin selected in GppPinId 0x00: 0 0x01: 1 ... 0xFF: 255 Reading returns the intensity index of the GPP pin selected in GppPinId. Default value is IntensityOn or IntensityOff depending on GpioOutPwrUp.

Table 33 I2C GPP Intensity

Address	Name	Bits	Description
0xB1	SoftReset	7:0	Writing 0xDE followed by 0x00 will reset the chip.

Table 34 I2C Soft Reset



6.6 SPM Gateway Registers

The SX8661Z I2C interface offers two registers for exchanging the SPM data with the host.

- SpmCfg
- SpmBaseAddr

Address	Name	Bits	Description
0x0D	SpmCfg	7:6	00: Reserved
		5:4	Defines the normal operation or SPM mode 00: I2C in normal operation mode (default) 01: I2C in SPM mode 10: Reserved 11: Reserved
		3	Defines r/w direction of SPM 0: SPM write access (default) 1: SPM read access
		2:0	000: Reserved

Table 35 SPM access configuration

Address	Name	Bits	Description
0x0E	SpmBaseAddr	7:0	SPM Base Address (modulo 8). The lowest address is 0x00 (default) The highest address is 0x78.

Table 36 SPM Base Address

The exchange of data, read and write, between the host and the SPM is always done in bursts of eight bytes. The base address of each burst of eight bytes is a modulo 8 number, starting at 0x00 and ending at 0x78.

The registers SpmKeyMsb and SpmKeyLsb are required for NVM programming as described in section 6.7.

Address	Name	Bits	Description
0xAC	SpmKeyMsb	7:0	SPM to NVM burn Key MSB Unlock requires writing data: 0x62

Table 37 SPM Key MSB at I2C register address 0xAC

Address	Name	Bits	Description
0xAD	SpmKeyLsb	7:0	SPM to NVM burn Key LSB Unlock requires writing data: 0x9D

Table 38 SPM Key LSB

**6.6.1 SPM Write Sequence**

The SPM must always be written in blocks of 8 bytes. The sequence is described below:

1. Set the I2C in SPM mode by writing "01" to SpmCfg[5:4] and SPM write access by writing '0' to SpmCfg[3].
2. Write the SPM base address to SpmBaseAddr (The base address needs to be a value modulo 8).
3. Write the eight consecutive bytes to I2C address 0, 1, 2, ...7
4. Terminate by writing "000" to SpmCfg[5:3].

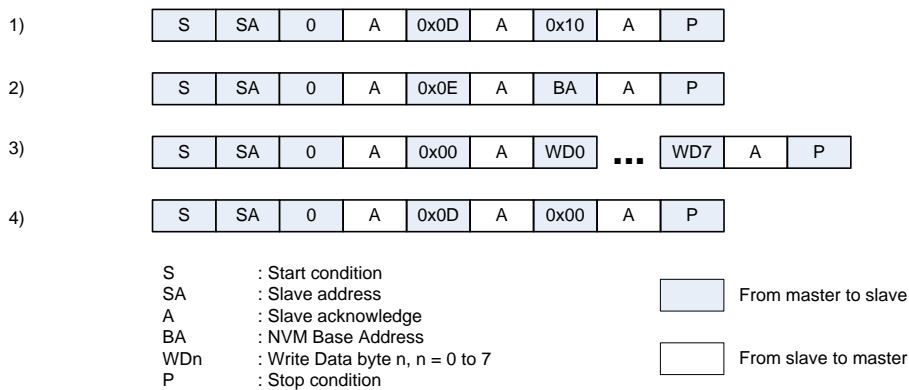

Figure 56 SPM write sequence

The complete SPM can be written by repeating 16 times the cycles shown in Figure 56 using base addresses 0x00, 0x08, 0x10, ... 0x70, 0x78.

Once the SPM write sequence is actually applied, the INTB pin will be asserted. The host clears the interrupt by reading any I2C register. At the same time the bit GenStatMsb[6], indicating the SPM write is done, will be cleared.

**6.6.2 SPM Read Sequence**

The SPM must always be read in blocks of 8 bytes. The sequence is described below:

1. Set the I2C in SPM mode by writing "01" to SpmCfg[5:4] and SPM read access by writing '1' to SpmCfg[3].
2. Write the SPM base address to SpmBaseAddr (The base address needs to be a value modulo 8).
3. Read the eight consecutive bytes from I2C address 0, 1, 2, ...7
4. Terminate by writing "000" to SpmCfg[5:3].

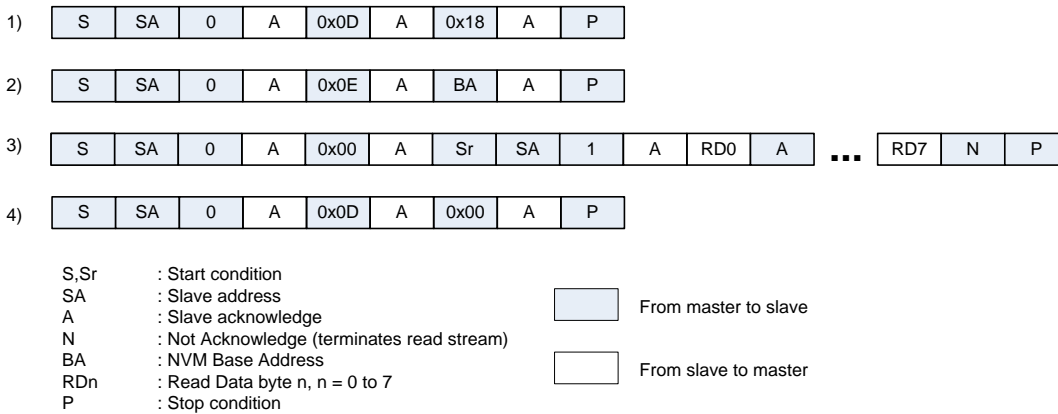

Figure 57 SPM Read Sequence

The complete SPM can be read by repeating 16 times the cycles shown in Figure 57 using base addresses 0x00, 0x08, 0x10, ..., 0x70, 0x78.

Once the SPM read sequence is actually applied, the INTB pin will be asserted. The host clears the interrupt by reading any I2C register. At the same time the bit GenStatMsb[6], indicating the SPM write is done, will be cleared.



6.7 NVM burn

The content of the SPM can be copied permanently (burned) into the NVM to be used as the new default parameters. The burning of the NVM can be done up to three times and must be done only when the SPM is completely written with the desired data.

The number of times the NVM has been burned can be monitored by reading NvmCycle from the I2C register GenStatLsb[7:5].

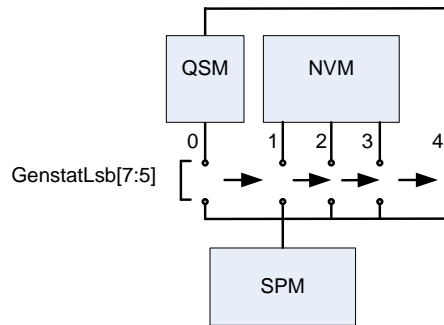

Figure 58 Simplified Diagram NvmCycle

Figure 58 shows the simplified diagram of the NvmCycle counter.

The SX8661Z is delivered with first NVM burned and NvmCycle set to one. The SPM points to the first NVM. Each NVM burn will increase the NvmCycle. At the fourth NVM burn the SX8661Z switches definitely to the QSM.

The burning of the SPM into the NVM is done by executing a special sequence of four I2C commands.

- | | |
|--|------------------------------------|
| 1. Write the data 0x62 to the I2C register I2CKeyMsb. | Terminate the I2C write by a STOP. |
| 2. Write the data 0x9D to the I2C register I2CKeyLsb. | Terminate the I2C write by a STOP. |
| 3. Write the data 0xA5 to the I2C register I2CSpmBaseAddr. | Terminate the I2C write by a STOP. |
| 4. Write the data 0x5A to the I2C register I2CSpmBaseAddr. | Terminate the I2C write by a STOP. |

This is illustrated in Figure 59.

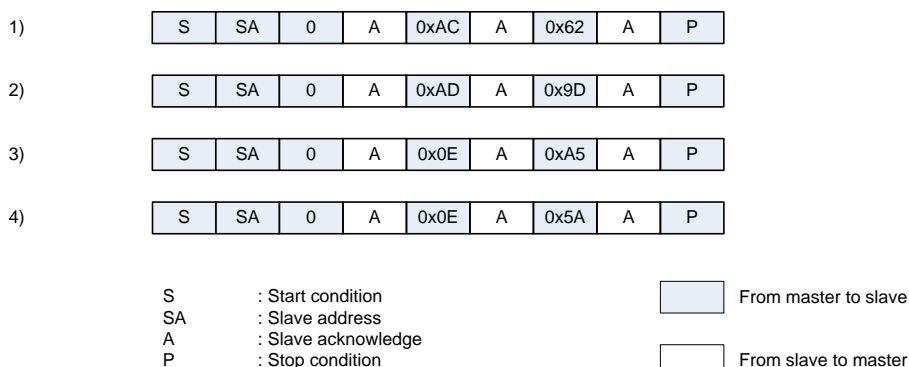

Figure 59: NVM burn procedure



6.8 Monitor Mode

Monitor mode allows the host to read “real-time” sensor information (CAPxRaw, CAPxAvg, CAPxDiff).

It is enabled by setting bit 2 of I2C register SpmCfg (address 0x0D).

When enabled, it uses a specific monitor scan period (Cf below) and generates an interrupt every time a new full set of data is available (hence every scan period).

Address	Name	Bits	Description
0xF9	MonitorScanPeriod	7:0	Monitor Mode Scan Period 0x00: Reserved 0x01: 15ms ... 0x0D: 195ms (default) ... 0xFF: 255 x 15ms

Monitor mode scan period is located at address 0xF9 can be written similarly as SPM data (Cf. §6.6.1). Interrupt is cleared normally by reading I2C register IrqSrc (address 0x00) but no specific flag is set.

CAPxRaw/Avg/Diff data can be read similarly as SPM data (Cf. §6.6.2).

Base address BA = 0xB4 is the beginning of the CAPxDiff data location and data are organized this way:

0xB4: CAP0Diff, MSB
0xB5: CAP0Diff, LSB
0xB6: CAP1Diff, MSB
etc...

Values are coded 16bits signed 2's complement format and updated at each scan period.

Base address BA = 0x80 is the beginning of the CAPxRaw data location.

Base address BA = 0x9A is the beginning of the CAPxAvg data location.

Data should be read before the next interrupt occurs (i.e. within one scan period).

**7 APPLICATION INFORMATION****7.1 Triple proximity reporting**

This section describes the application corresponding to QSM settings
One AOI with seven LEDs are used. The intensity level of the LEDs show if proximity (medium intensity) or a touch (maximum intensity) is detected. The LEDs are off in case no finger is present.

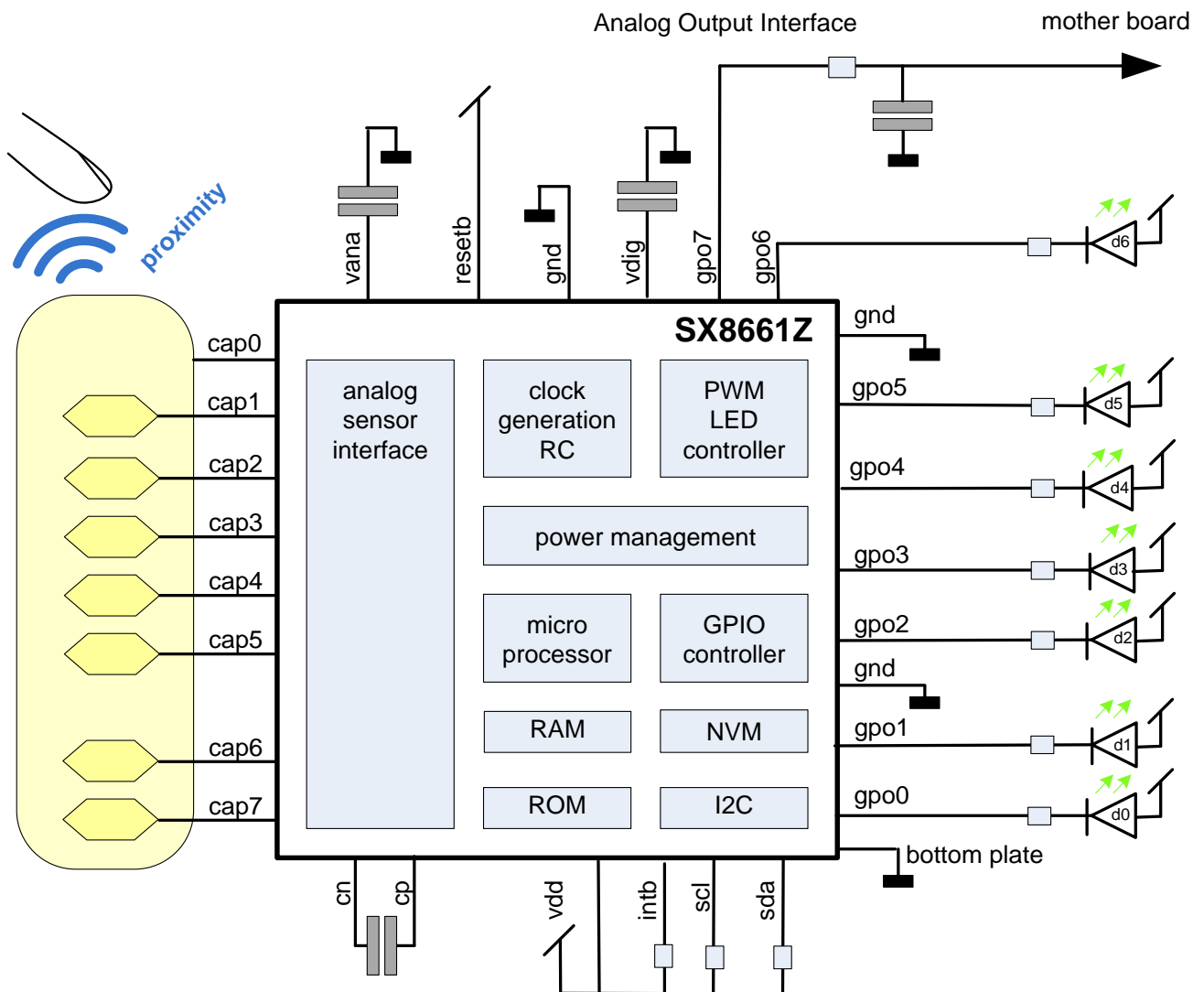

Figure 60 Typical Application (one AOI), triple proximity reporting

In case of proximity all LEDs (d0 to d6) are enabled to a medium intensity.
If a sensor is touched then only the corresponding LED will light up with full intensity. The other LEDs remain at medium intensity.

7.2 Dual proximity reporting

Two AOIs and two LEDs are used. One LED is showing proximity and the second LED (or multiple LEDs) for showing any touch.

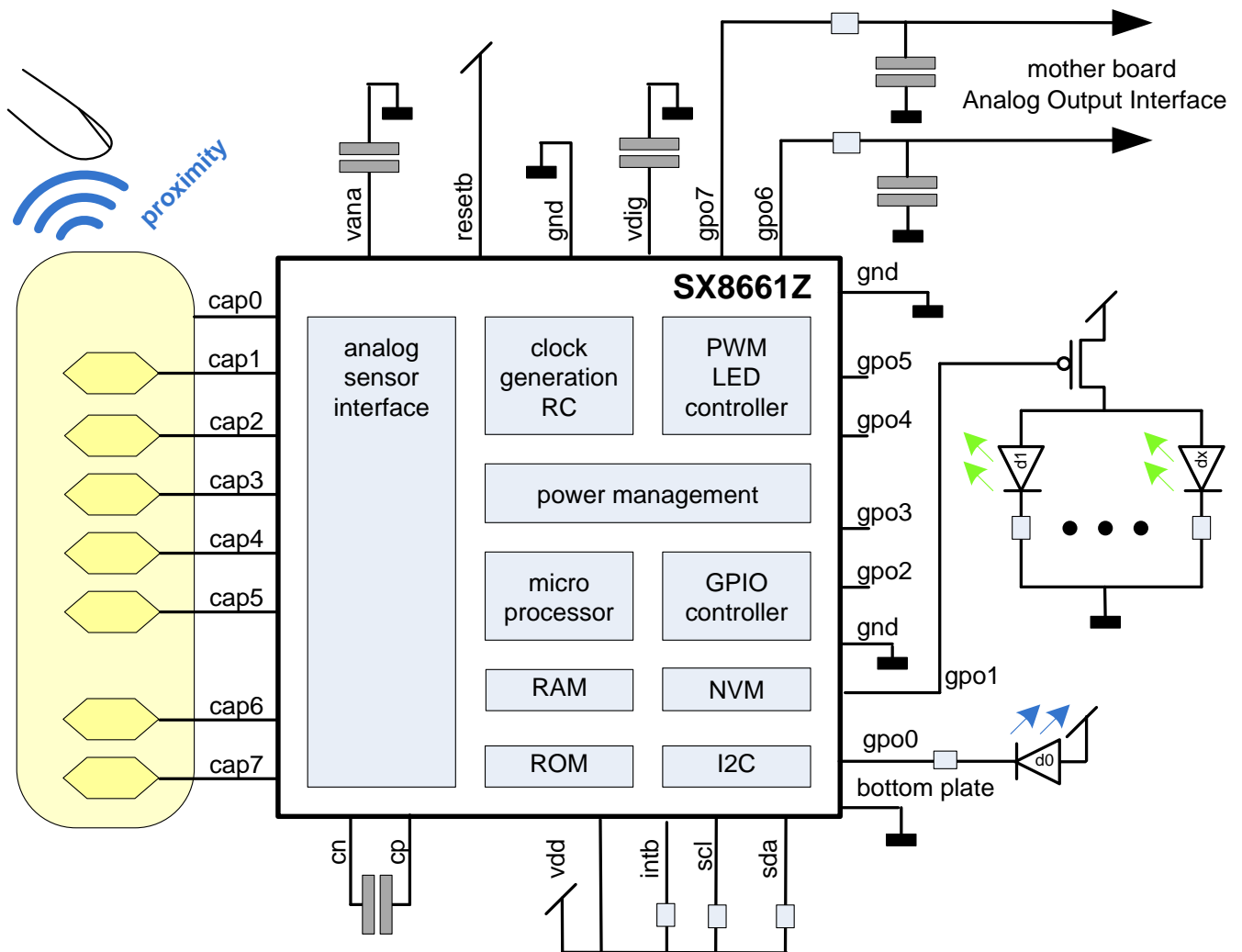

Figure 61 Typical Application (two AOI), dual proximity reporting

*Figure 62 dual proximity LED and AOI reporting*

Figure 62 shows the reporting on the LEDs and the AOI for the application with two AOIs. On proximity all the LEDs (d1 to dx) are enabled to maximum light intensity. A touch on any button is shown by the continuous fading in and fading out of the LED d0.

	AOI-A	AOI-B
prox	idle	idle
key1	0.6V	idle
key2	0.9V	idle
key3	1.2V	idle
key4	idle	1.5V
key5	idle	1.8V
key6	idle	2.1V
key7	idle	2.4V

Table 39 example AOI-A, AOIB

**ADVANCED COMMUNICATIONS & SENSING****DATASHEET**

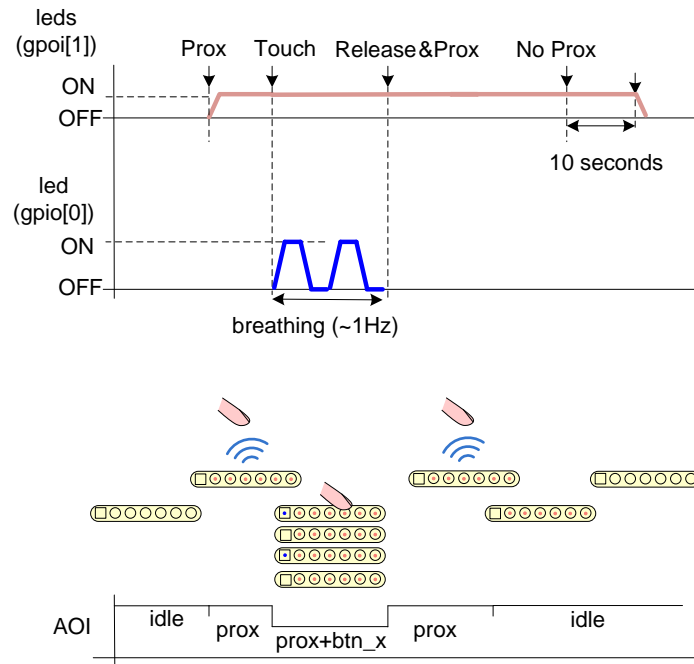
7.2.1 SPM file (application two AOI, dual proximity reporting)

#Address[Hex]	Value[Hex]	#Address[Hex]	Value[Hex]
0x00	0xxx	0x40	0xFE
0x01	0xxx	0x41	0x00
0x02	0x41	0x42	0x00
0x03	0xxx	0x43	0xF0
0x04	0x2B	0x44	0x00
0x05	0x02	0x45	0xFF
0x06	0x0D	0x46	0xFF
0x07	0x00	0x47	0xFF
0x08	0x00	0x48	0xFF
0x09	0x05	0x49	0xFF
0x0A	0x00	0x4A	0xFF
0x0B	0x55	0x4B	0xFF
0x0C	0x57	0x4C	0xFF
0x0D	0x73	0x4D	0x00
0x0E	0x33	0x4E	0x00
0x0F	0x33	0x4F	0x00
0x10	0x33	0x50	0x00
0x11	0x00	0x51	0x00
0x12	0x00	0x52	0x00
0x13	0xA0	0x53	0x00
0x14	0xA0	0x54	0x00
0x15	0xA0	0x55	0xFF
0x16	0xA0	0x56	0x00
0x17	0xA0	0x57	0xC3
0x18	0xA0	0x58	0xC0
0x19	0xA0	0x59	0xC0
0x1A	0xA0	0x5A	0x00
0x1B	0x00	0x5B	0x00
0x1C	0x00	0x5C	0x04
0x1D	0x00	0x5D	0x44
0x1E	0x0A	0x5E	0x44
0x1F	0x00	0x5F	0x44
0x20	0x70	0x60	0x00
0x21	0x50	0x61	0x44
0x22	0x50	0x62	0x44
0x23	0x01	0x63	0x44
0x24	0x0A	0x64	0x00
0x25	0x00	0x65	0xEE
0x26	0x80	0x66	0xEE
0x27	0x00	0x67	0xE0
0x28	0x00	0x68	0x00
0x29	0x00	0x69	0x00
0x2A	0xFF	0x6A	0x00
0x2B	0x01	0x6B	0x00
0x2C	0xAA	0x6C	0x00
0x2D	0x55	0x6D	0x00
0x2E	0xFF	0x6E	0x01
0x2F	0x2E	0x6F	0x50
0x30	0x45	0x70	0x74
0x31	0x5D	0x71	0x10
0x32	0x74	0x72	0x45
0x33	0x8B	0x73	0x03
0x34	0xA3	0x74	0xFF
0x35	0xBA	0x75	0xFF
0x36	0xFF	0x76	0xFF
0x37	0xA4	0x77	0xD5
0x38	0x40	0x78	0x55
0x39	0x20	0x79	0x55
0x3A	0x00	0x7A	0x7F
0x3B	0x00	0x7B	0x23
0x3C	0x00	0x7C	0x22
0x3D	0x00	0x7D	0x41
0x3E	0x0C	0x7E	0xFF
0x3F	0x00	0x7F	0x3D



7.3 Example of Touch+Proximity Module

7.3.1 Overview

To demonstrate the proximity sensing feature of the SX8661Z/SX863x family, a module has been designed and is illustrated in figure below.

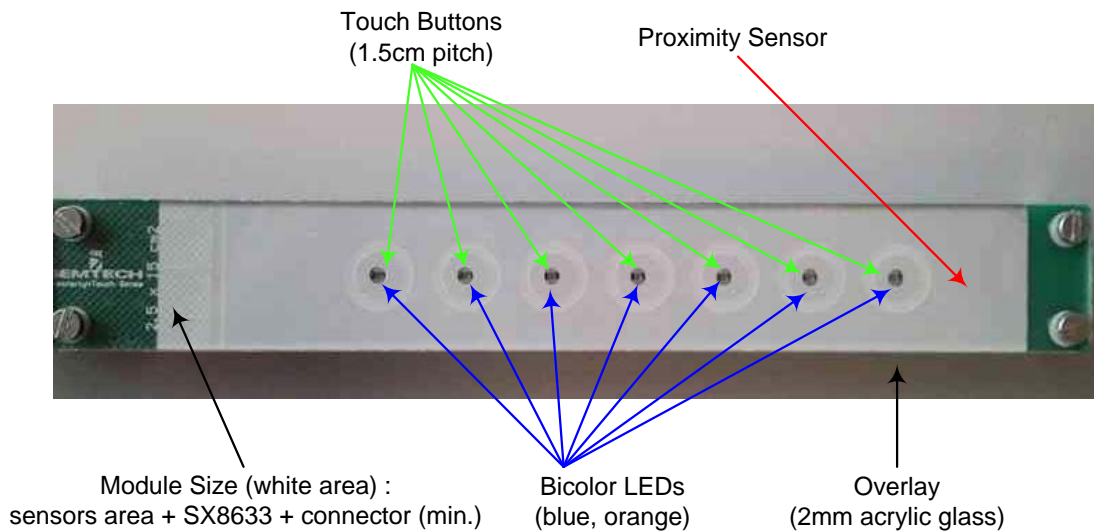

Figure 63 Touch+Proximity Module Overview

The touch button controller is running in stand-alone (i.e. without host) and uses the Autolight mode to turn LEDs ON/OFF accordingly to the touch buttons and proximity sensing status.

7.3.2 Operation

Module operation can be seen as 5 steps which are described in figure below



Figure 64 Touch+Proximity Module Operation

Notes:

- For better user experience, bicolor LEDs have been used here but one could decide to design a module with normal unicolor LEDs. In this case, step 3 above would simply consist in a higher (blue) intensity for the LED of the button touched.
- For obvious demonstration purposes the overlay used here is transparent but in typical applications (TV, Monitor, Set-top box, etc) the overlay would be opaque enough so that when LEDs are OFF (i.e. no proximity detected) the PCB is not visible to the user.



ADVANCED COMMUNICATIONS & SENSING DATASHEET

7.3.3 Performance

The proximity sensing distance of detection has been measured in these conditions:

- CapProxEnable = ON
- CapSensitivity = 7 (Max)
- CapThreshold = 300
- Board main supplied and placed vertically i.e. same orientation as hand/finger
- Finger pointing center button

The results obtained are provided in table below:

	Distance of Detection
Palm	~10cm
Finger (natural position)	~6cm
Orthogonal finger (worst case)	~4cm

Table 40 Proximity Sensing Distance of Detection

7.3.4 Schematics

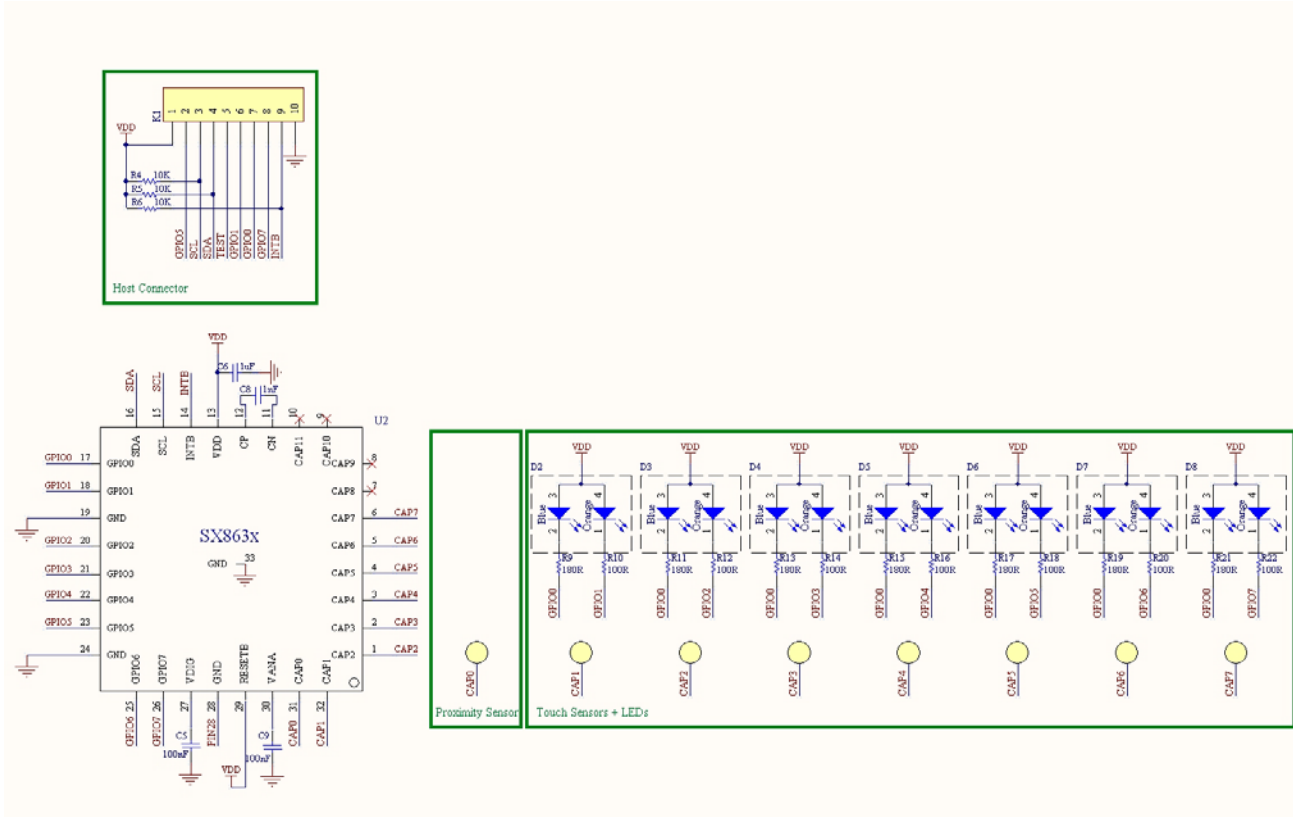

Figure 65 Touch+Proximity Module Schematics



7.3.5 Layout

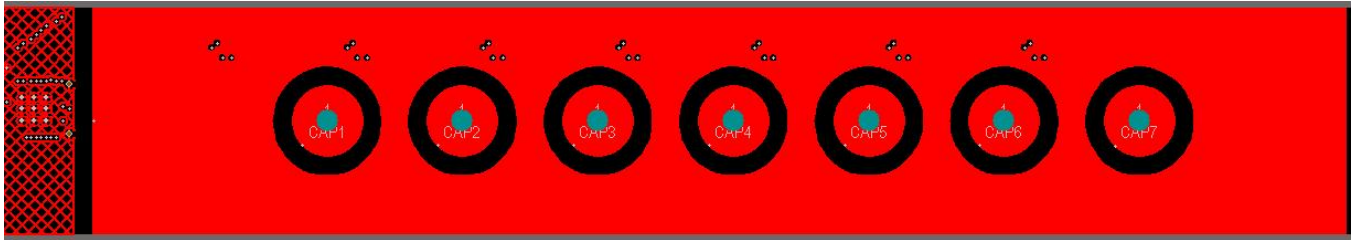

Figure 66 Touch+Proximity Module Layout - Top

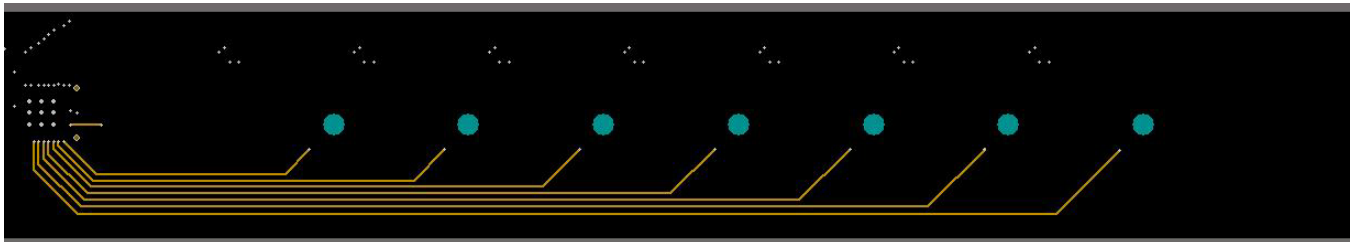

Figure 67 Touch+Proximity Module Layout - Mid1

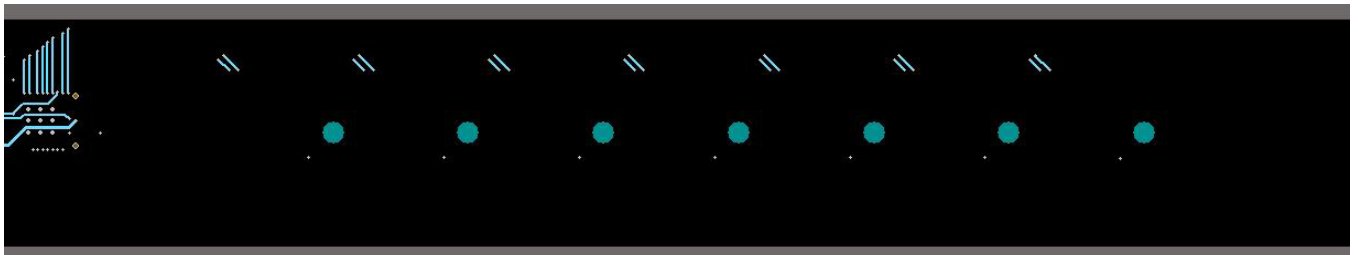

Figure 68 Touch+Proximity Module Layout - Mid2

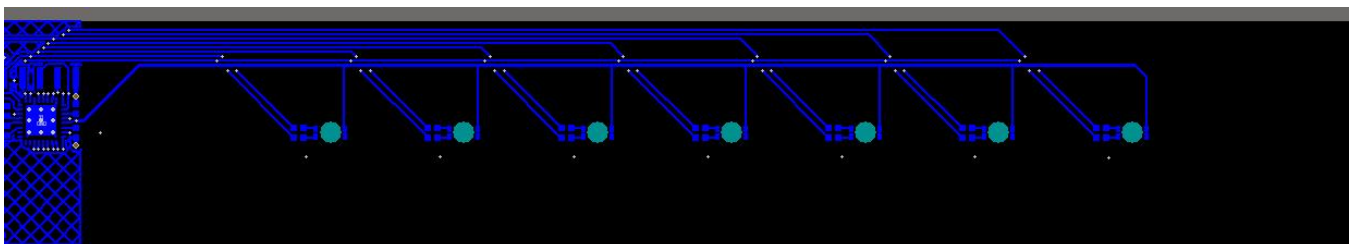

Figure 69 Touch+Proximity Module Layout - Bottom

8 REFERENCES

[1] Capacitive Touch Sensing Layout guidelines on www.semtech.com

**9 PACKAGING INFORMATION****9.1 Package Outline Drawing**

SX8661Z is assembled in a MLPQ-UT28 package as shown in Figure 70.

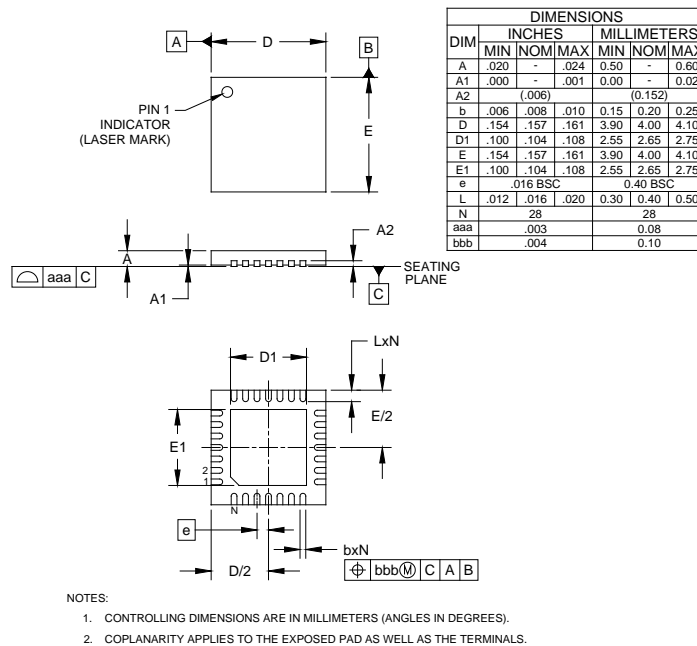
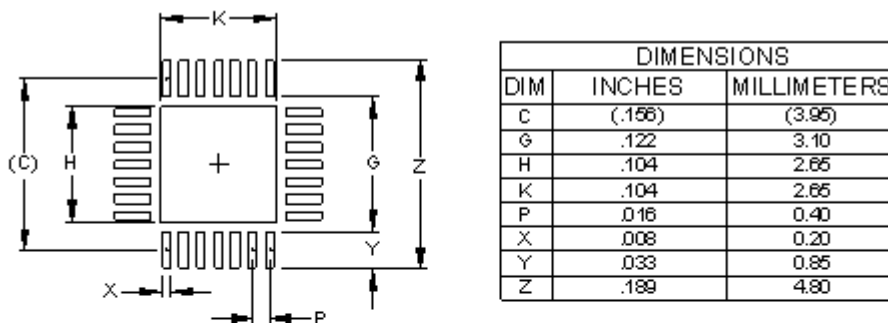

Figure 70 Package outline drawing

9.2 Land Pattern

The land pattern of MLPQ-UT28 package, 4 mm x 4 mm is shown in Figure 71.



- NOTES:
1. CONTROLLING DIMENSIONS ARE IN MILLIMETERS (ANGLES IN DEGREES).
 2. THIS LAND PATTERN IS FOR REFERENCE PURPOSES ONLY. CONSULT YOUR MANUFACTURING GROUP TO ENSURE YOUR COMPANY'S MANUFACTURING GUIDELINES ARE MET.
 3. THERMAL VIAS IN THE LAND PATTERN OF THE EXPOSED PAD SHALL BE CONNECTED TO A SYSTEM GROUND PLANE. FAILURE TO DO SO MAY COMPROMISE THE THERMAL AND/OR FUNCTIONAL PERFORMANCE OF THE DEVICE.
 4. SQUARE PACKAGE DIMENSIONS APPLY IN BOTH X AND Y DIRECTIONS.

Figure 71 Land pattern



© Semtech 2012

All rights reserved. Reproduction in whole or in part is prohibited without the prior written consent of the copyright owner. The information presented in this document does not form part of any quotation or contract, is believed to be accurate and reliable and may be changed without notice. No liability will be accepted by the publisher for any consequence of its use. Publication thereof does not convey nor imply any license under patent or other industrial or intellectual property rights. Semtech assumes no responsibility or liability whatsoever for any failure or unexpected operation resulting from misuse, neglect improper installation, repair or improper handling or unusual physical or electrical stress including, but not limited to, exposure to parameters beyond the specified maximum ratings or operation outside the specified range.

SEMTECH PRODUCTS ARE NOT DESIGNED, INTENDED, AUTHORIZED OR WARRANTED TO BE SUITABLE FOR USE IN LIFE-SUPPORT APPLICATIONS, DEVICES OR SYSTEMS OR OTHER CRITICAL APPLICATIONS. INCLUSION OF SEMTECH PRODUCTS IN SUCH APPLICATIONS IS UNDERSTOOD TO BE UNDERTAKEN SOLELY AT THE CUSTOMER'S OWN RISK. Should a customer purchase or use Semtech products for any such unauthorized application, the customer shall indemnify and hold Semtech and its officers, employees, subsidiaries, affiliates, and distributors harmless against all claims, costs damages and attorney fees which could arise.

Notice: All referenced brands, product names, service names and trademarks are the property of their respective owners.

Contact Information

Semtech Corporation
Advanced Communications and Sensing Products Division
200 Flynn Road, Camarillo, CA 93012
Phone: (805) 498-2111 Fax: (805) 498-3804