

**TTL-to-DIFFERENTIAL  
ECL TRANSLATOR****SY100ELT24****FEATURES**

- 500ps typical propagation delay
- Differential ECL output
- PNP TTL input for minimal loading
- Flow-through pinouts
- Available in 8-pin SOIC package

**DESCRIPTION**

The SY100ELT24 is a TTL-to-differential ECL translator. Because ECL levels are used, a +5V, -5.2V (or -4.5V) and ground are required. The small outline 8-lead SOIC package and the single gate of the ELT24 makes it ideal for those applications where performance, space and low power are at a premium.

**PIN NAMES**

Pin	Function
Q, $\bar{Q}$	Differential ECL Output
D	TTL Input
Vcc	Positive Supply
VEE	Negative Supply
GND	Ground

## PACKAGE/ORDERING INFORMATION

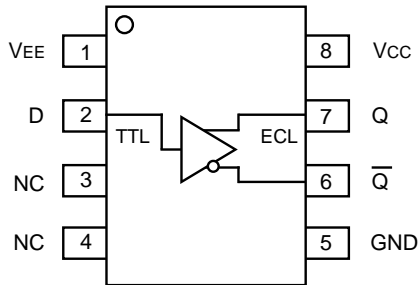

8-Pin SOIC (Z8-1)

### Ordering Information<sup>(1)</sup>

Part Number	Package Type	Operating Range	Package Marking	Lead Finish
SY100ELT24ZC	Z8-1	Commercial	XEL24	Sn-Pb
SY100ELT24ZCTR <sup>(2)</sup>	Z8-1	Commercial	XEL24	Sn-Pb
SY100ELT24ZI	Z8-1	Industrial	XEL24	Sn-Pb
SY100ELT24ZITR <sup>(2)</sup>	Z8-1	Industrial	XEL24	Sn-Pb
SY100ELT24ZG <sup>(3)</sup>	Z8-1	Industrial	XEL24 with Pb-Free bar-line indicator	Pb-Free NiPdAu
SY100ELT24ZGTR <sup>(2, 3)</sup>	Z8-1	Industrial	XEL24 with with Pb-Free bar-line indicator	Pb-Free NiPdAu

**Notes:**

1. Contact factory for die availability. Dice are guaranteed at  $T_A = 25^\circ\text{C}$ , DC Electricals only.
2. Tape and Reel.
3. Pb-Free package is recommended for new designs.

**ABSOLUTE MAXIMUM RATINGS<sup>(1)</sup>**

Symbol	Parameter	Value	Unit
V <sub>CC</sub>	Power Supply Voltage	-0.5 to +7.0	V
V <sub>I</sub>	TTL Input Voltage	-0.5 to V <sub>CC</sub>	V
I <sub>I</sub>	TTL Input Current	-30 to +5.0	mA
I <sub>OUT</sub>	ECL Output Current — Continuous — Surge	50 100	mA
T <sub>LEAD</sub>	Lead Temperature (soldering, 20sec.)	+260	°C
T <sub>store</sub>	Storage Temperature	-65 to +150	°C
T <sub>A</sub>	Operating Temperature	-40 to +85	°C

**TRUTH TABLE**

D	Q	$\bar{Q}$
H	H	L
L	L	H
Open	H	L

**NOTE:**

1. Permanent device damage may occur if absolute maximum ratings are exceeded. This is a stress rating only and functional operation is not implied at conditions other than those detailed in the operational sections of this data sheet. Exposure to absolute maximum rating conditions for extended periods may affect device reliability.

**DC ELECTRICAL CHARACTERISTICS**V<sub>CC</sub> = 4.5V to 5.5V; V<sub>EE</sub> = -4.2V to -5.5V

Symbol	Parameter	T <sub>A</sub> = -40°C		T <sub>A</sub> = 0°C		T <sub>A</sub> = +25°C		T <sub>A</sub> = +85°C		Unit	Condition
		Min.	Max.	Min.	Max.	Min.	Max.	Min.	Max.		
I <sub>CC</sub>	Power Supply Current	—	10	—	10	—	10	—	10	mA	—
I <sub>EE</sub>	Power Supply Current	—	20	—	20	—	20	—	20	mA	No output load

**AC ELECTRICAL CHARACTERISTICS**V<sub>CC</sub> = 4.5V to 5.5V; V<sub>EE</sub> = -4.2V to -5.5V

Symbol	Parameter	T <sub>A</sub> = -40°C		T <sub>A</sub> = 0°C		T <sub>A</sub> = +25°C			T <sub>A</sub> = +85°C		Unit	Condition
		Min.	Max.	Min.	Max.	Min.	Typ.	Max.	Min.	Max.		
t <sub>PLH</sub> t <sub>PHL</sub>	Propagation Delay	300	900	300	900	300	500	900	300	900	ps	50Ω to -2.0V
t <sub>r</sub> t <sub>f</sub>	Output Rise/Fall Time 20% to 80%	200	700	200	700	200	300	700	200	700	ps	50Ω to -2.0V
f <sub>MAX</sub>	Maximum Input Frequency	200	—	200	—	200	—	—	200	—	MHz	

## TTL DC ELECTRICAL CHARACTERISTICS

VCC = 4.5V to 5.5V; VEE = -4.2V to -5.5V

Symbol	Parameter	TA = -40°C		TA = 0°C		TA = +25°C		TA = +85°C		Unit	Condition
		Min.	Max.	Min.	Max.	Min.	Max.	Min.	Max.		
V <sub>IH</sub>	Input HIGH Voltage	2.0	—	2.0	—	2.0	—	2.0	—	V	—
V <sub>IL</sub>	Input LOW Voltage	—	0.8	—	0.8	—	0.8	—	0.8	V	—
I <sub>IH</sub>	Input HIGH Current	—	20 100	—	20 100	—	20 100	—	20 100	μA	V <sub>IN</sub> = 2.7V V <sub>IN</sub> = V <sub>CC</sub>
I <sub>IL</sub>	Input LOW Current	—	-0.6	—	-0.6	—	-0.6	—	-0.6	mA	V <sub>IN</sub> = 0.5V
V <sub>IK</sub>	Input Clamp Voltage	—	-1.2	—	-1.2	—	-1.2	—	-1.2	V	I <sub>IN</sub> = -18mA

## ECL DC ELECTRICAL CHARACTERISTICS

VCC = 4.5V to 5.5V; VEE = -4.2V to -5.5V

Symbol	Parameter	TA = -40°C		TA = 0°C		TA = +25°C		TA = +85°C		Unit	Condition
		Min.	Max.	Min.	Max.	Min.	Max.	Min.	Max.		
V <sub>OH</sub>	Output HIGH Voltage	-1085	-880	-1025	-880	-1025	-880	-1025	-880	mV	50Ω to -2.0V
V <sub>OL</sub>	Output LOW Voltage	-1830	-1555	-1810	-1620	-1810	-1620	-1810	-1620	mV	50Ω to -2.0V

**8-PIN SOIC .150" WIDE (Z8-1)**

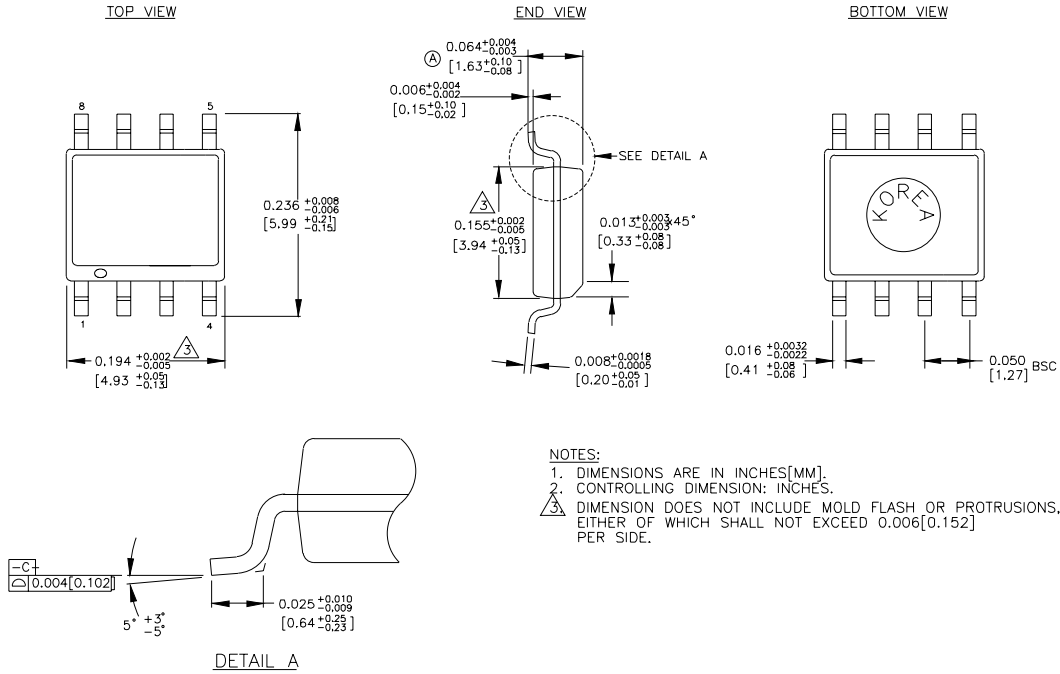

Rev. 03

**MICREL, INC. 2180 FORTUNE DRIVE SAN JOSE, CA 95131 USA**

TEL + 1 (408) 944-0800 FAX + 1 (408) 474-1000 WEB <http://www.micrel.com>

The information furnished by Micrel in this datasheet is believed to be accurate and reliable. However, no responsibility is assumed by Micrel for its use. Micrel reserves the right to change circuitry and specifications at any time without notification to the customer.

Micrel Products are not designed or authorized for use as components in life support appliances, devices or systems where malfunction of a product can reasonably be expected to result in personal injury. Life support devices or systems are devices or systems that (a) are intended for surgical implant into the body or (b) support or sustain life, and whose failure to perform can be reasonably expected to result in a significant injury to the user. A Purchaser's use or sale of Micrel Products for use in life support appliances, devices or systems is at Purchaser's own risk and Purchaser agrees to fully indemnify Micrel for any damages resulting from such use or sale.

© 2006 Micrel, Incorporated.