

FEATURES

- 425ps propagation delay
- 1.6V output swings
- Single +5V operation
- Internal 75KΩ input pull-down resistors
- Available in 16-pin SOIC package

LOGIC DIAGRAM

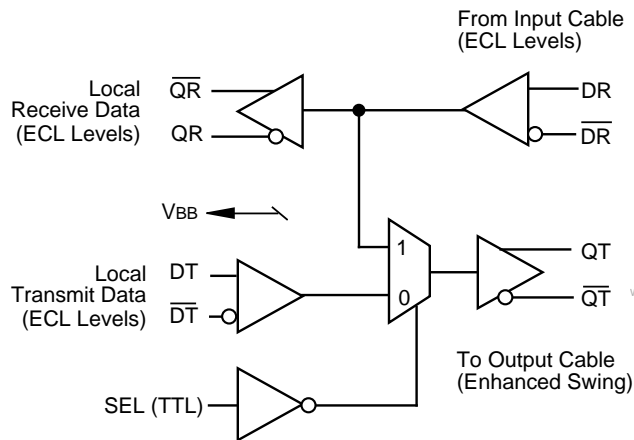

PIN CONFIGURATION

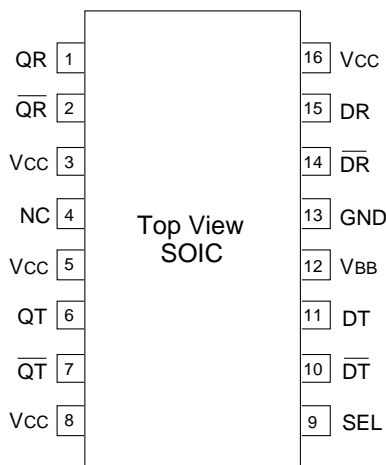

DESCRIPTION

The SY10EL1189 is a differential receiver, differential transmitter specifically designed to drive coaxial cables. It incorporates the output cable driver capability of the SY10EL89 Coaxial Cable Driver with additional circuitry to multiplex the output cable drive source between the cable receiver or the local transmitter inputs. The multiplexer control circuitry is TTL compatible for ease of operation.

The SY10EL1189 is useful as a bypass element for Fibre Channel-Arbitrated Loop (FC-AL) or Serial Storage Architecture (SSA) applications, to create loop style interconnects with fault tolerant, active switches at each device node. This device is particularly useful for back panel applications where small size is desirable.

The EL89 style drive circuitry produces swings twice as large as a standard PECL output. When driving a coaxial cable, proper termination is required at both ends of the line to minimize reflections. The 1.6V output swings allow for proper termination at both ends of the cable. Because of the larger output swings, the QT, QT-bar outputs are terminated into the thevenin equivalent of 50Ω to VCC-3.0V instead of 50Ω to VCC-2.0V.

PIN NAMES

Pin	Function
DR/DR-bar	Differential Input from Receive Cable
QR/QR-bar	Buffered Differential Output from Receive Cable
DT/DT-bar	Differential Input to Transmit Cable
QT/QT-bar	Buffered Differential Output to Transmit Cable
SEL	Multiplexer Control Signal (TTL)
Vcc	Positive Power Supply
GND	Ground
VBB	Reference Voltage Output

TRUTH TABLE

SEL	Function
L	DR → QT
H	DT → QT

ABSOLUTE MAXIMUM RATINGS⁽¹⁾

Symbol	Rating	Value	Unit
V _{CC}	Power Supply Voltage (Referenced to GND)	0 to +7.0	V
V _{IN}	Input Voltage (Referenced to GND)	0 to V _{CC}	V
I _{OUT}	Output Current — Continuous — Surge	50 100	mA
T _A	Operating Temperature Range	-40 to +85	°C
T _{store}	Storage Temperature Range	-50 to +150	°C
V _{CC}	Operating Voltage Range ⁽²⁾	4.5 to 5.5	V

NOTES:

1. Permanent device damage may occur if ABSOLUTE MAXIMUM RATINGS are exceeded. This is a stress rating only and functional operation is not implied at conditions other than those detailed in the operational sections of this data sheet. Exposure to ABSOLUTE MAXIMUM RATING conditions for extended periods may affect device reliability.
2. Parametric values specified at 4.75 to 5.25V.

DC ELECTRICAL CHARACTERISTICS⁽¹⁾V_{CC} = 5.0V, GND = 0V

Symbol	Parameter	T _A = -40°C			T _A = 0°C			T _A = +25°C			T _A = +85°C			Unit
		Min.	Typ.	Max.	Min.	Typ.	Max.	Min.	Typ.	Max.	Min.	Typ.	Max.	
V _{OL}	Output LOW Voltage ^(2,3) (Q _R , \overline{Q}_R)	3.05	3.23	3.35	3.05	3.24	3.37	3.05	3.24	3.37	3.05	3.25	3.41	V
V _{OH}	Output HIGH Voltage ^(2,3) (Q _R , \overline{Q}_R)	3.92	4.05	4.11	3.98	4.09	4.16	4.02	4.11	4.19	4.09	4.16	4.28	V
V _{OL}	Output LOW Voltage ^(2,4) (Q _T , \overline{Q}_T)	1.94	2.22	2.50	1.83	2.12	2.41	1.80	2.10	2.39	1.77	2.06	2.35	V
V _{OH}	Output HIGH Voltage ^(2,4) (Q _T , \overline{Q}_T)	3.71	3.89	4.08	3.79	3.98	4.17	3.83	4.02	4.20	3.90	4.09	4.28	V
I _{CC}	Quiescent Supply Current ⁽⁵⁾	20	25	42	22	26	47	23	27	47	25	28	47	mA
V _{IL}	Input LOW Voltage ⁽²⁾ (D _R , \overline{D}_R & D _T , \overline{D}_T)	3.05	—	3.50	3.05	—	3.52	3.05	—	3.52	3.05	—	3.56	V
V _{IH}	Input HIGH Voltage ⁽²⁾ (D _R , \overline{D}_R & D _T , \overline{D}_T)	3.77	—	4.11	3.83	—	4.16	3.87	—	4.19	3.94	—	4.28	V
I _{IL}	Input LOW Current (D _R , \overline{D}_R & D _T , \overline{D}_T)	—	—	150	—	—	150	—	—	150	—	—	150	μA
I _{IH}	Input HIGH Current (D _R , \overline{D}_R & D _T , \overline{D}_T)	0.5	—	—	0.5	—	—	0.5	—	—	0.5	—	—	μA
V _{IL}	Input LOW Voltage SEL	—	—	0.8	—	—	0.8	—	—	0.8	—	—	0.8	V
V _{IH}	Input HIGH Voltage SEL	2.0	—	—	2.0	—	—	2.0	—	—	2.0	—	—	V
I _{IL}	Input LOW Current SEL V _{IN} = 500mV	—	—	600	—	—	600	—	—	600	—	—	600	μA
I _{IH}	Input HIGH Current SEL V _{IN} = 2.7V V _{IN} = V _{CC}	—	—	20 100	—	—	20 100	—	—	20 100	—	—	20 100	μA
V _{BB}	Output Reference Voltage ⁽²⁾	3.57	3.63	3.70	3.62	3.67	3.73	3.65	3.70	3.75	3.69	3.75	3.81	V

NOTES:

1. 10EL circuits are designed to meet the DC specifications shown in the table after thermal equilibrium has been established. The circuit is mounted in a test socket or mounted on a printed circuit board and transverse air greater than 500lfm is maintained.
2. Values will track 1:1 with the V_{CC} supply.
3. Outputs loaded with 50Ω to +3.0V.
4. Outputs loaded with 50Ω to +2.0V.
5. Outputs open circuited.

AC ELECTRICAL CHARACTERISTICS⁽¹⁾

VCC = 4.75 to 5.25V

Symbol	Parameter	TA = -40°C			TA = 0°C to 85°C			Unit	Condition	
		Min.	Typ.	Max.	Min.	Typ.	Max.			
tPLH tPHL	Propagation Delay to Output	DR → QR (Diff) (SE)	175 150	300 300	450 500	225 175	325 325	500 550	ps	Note 2 Note 3
		DR → QT (Diff) (SE)	250 225	425 425	650 700	300 250	450 450	650 700		
		DT → QT (Diff) (SE)	225 200	400 400	650 725	275 225	425 425	650 725		
tPLH tPHL	Propagation Delay	SEL → QT, \overline{QT}	450	600	850	500	650	800	ps	1.5V to 50% Pt
tr tf	Rise/Fall Time (20% to 80%)	QR, \overline{QR}	100	275	400	125	275	400	ps	
tr tf	Rise/Fall Time (20% to 80%)	QT, \overline{QT}	150	300	550	150	300	550	ps	
tskew	Within Device Skew ⁽⁴⁾		—	15	—	—	15	—	ps	
VPP	Minimum Input Swing ⁽⁵⁾		200	—	—	200	—	—	mV	
VCMR	Common Mode Range ⁽⁶⁾		3.00	—	4.35	3.00	—	4.35	V	

NOTES:

- 10EL circuits are designed to meet the DC specifications shown in the table after thermal equilibrium has been established. The circuit is mounted in a test socket or mounted on a printed circuit board and transverse air greater than 500lfm is maintained.
- The differential propagation delay is defined as the delay from the crossing points of the differential input signals to the crossing point of the differential output signals.
- The single-ended propagation delay is defined as the delay from the 50% point of the input signal to the 50% point of the output signal.
- Duty cycle skew is the difference between tPLH and tPHL propagation delay through a device.
- Minimum input swing for which AC parameters are guaranteed.
- The CMR range is referenced to the most positive side of the differential input signal. Normal operation is obtained if the HIGH level falls within the specified range and the peak-to-peak voltage lies between VPP Min. and 1.0V.

PRODUCT ORDERING CODE

Ordering Code	Package Type	Operating Range	Marking Code
SY10EL1189ZC	Z16-2	Commercial	HEL1189
SY10EL1189ZCTR*	Z16-2	Commercial	HEL1189

Ordering Code	Package Type	Operating Range	Marking Code
SY10EL1189ZI ⁽¹⁾	Z16-2	Industrial	HEL1189
SY10EL1189ZITR ⁽¹⁾	Z16-2	Industrial	HEL1189

*Tape and Reel

Note 1. Recommended for new designs.

16 LEAD SOIC .150" WIDE (Z16-2)

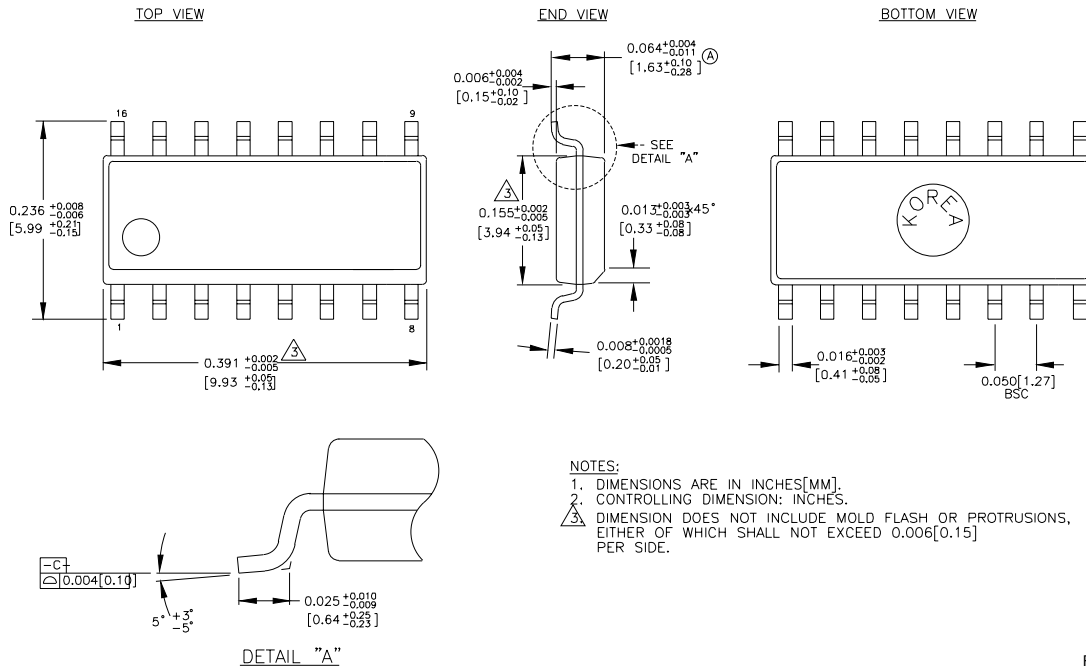

Rev. 02

MICREL, INC. 1849 FORTUNE DRIVE SAN JOSE, CA 95131 USA

TEL + 1 (408) 944-0800 FAX + 1 (408) 944-0970 WEB <http://www.micrel.com>

The information furnished by Micrel in this datasheet is believed to be accurate and reliable. However, no responsibility is assumed by Micrel for its use. Micrel reserves the right to change circuitry and specifications at any time without notification to the customer.

Micrel Products are not designed or authorized for use as components in life support appliances, devices or systems where malfunction of a product can reasonably be expected to result in personal injury. Life support devices or systems are devices or systems that (a) are intended for surgical implant into the body or (b) support or sustain life, and whose failure to perform can be reasonably expected to result in a significant injury to the user. A Purchaser's use or sale of Micrel Products for use in life support appliances, devices or systems is at Purchaser's own risk and Purchaser agrees to fully indemnify Micrel for any damages resulting from such use or sale.

© 2003 Micrel, Incorporated.