

# HIGH TORQUE HYBRID STEPPING MOTOR SPECIFICATIONS

General specifications		Electrical specifications	
Step Angle (°)	1.8	Rated Voltage (V)	7.28
Temperature Rise (°C)	80 Max (rated current, 2 phase on)	Rated Current (A)	0.28
Ambient Temperature (°C)	-20~+50	Resistance Per Phase ( $\pm 10\%$ $\Omega$ )	26
Number of Phase	2	Inductance Per Phase ( $\pm 20\%$ mH)	19.2
Insulation Resistance (M $\Omega$ )	100 Min (500VDC)	Holding Torque (N.cm)	6.5
Insulation Class	Class B		
Max.radial force (N)	28 (20mm from the flange)		
Max.axial force (N)	10		

● Wiring Diagram :

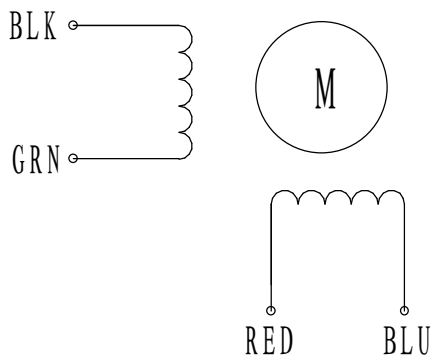

● Pull out torque curve:

VOLTAGE: 24VAC, CONSTANT CURRENT: 0.28, HALF STEP

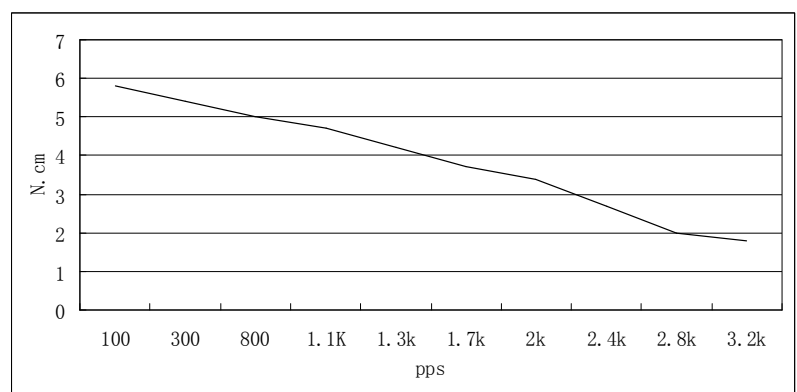

● Dimensions:

(unit=mm)

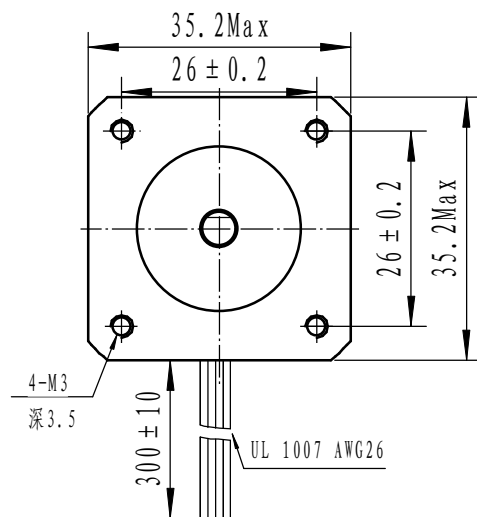
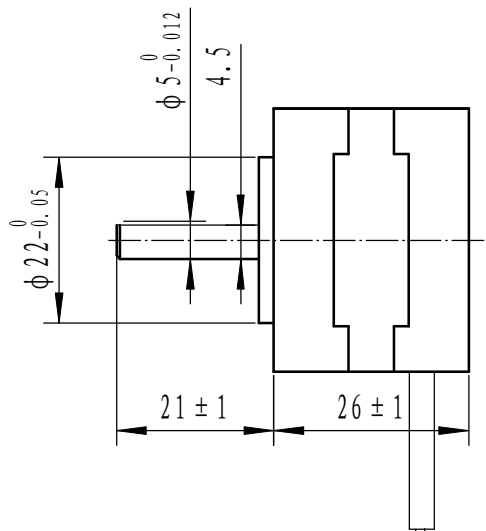

REV	REVISIONS	DESCRIPTION	BY	DATE	SY35ST26-0284A	TECHNICAL CONDITIONS
DRAW	2012/12/28					
CHECK						
APPROVE						