



Application Note: AN_SY6952B

2A Single-Cell High Efficiency Switching Charger with Adaptive Input Current Limit

General Description

SY6952B is a 4.0-23V input, 2A single-cell synchronous buck Li-Ion battery charger, suitable for portable application. Select pin is convenient for different cell voltage. Integrated 800 kHz synchronous buck regulator consists of 23V rating FETs with extremely low ON resistance to achieve high charge efficiency and simple peripheral circuit design.

Ordering Information

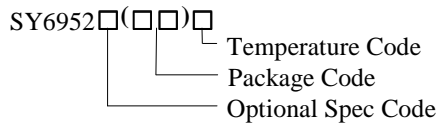

Temperature Range: -40°C to 85°C

Ordering Number	Package type	Note
SY6952BFCC	SO8E	

Features

- Wide Input Voltage Range: 4.0V to 23V
- High Efficiency Int. Synchronous Buck Regulator with Fixed 800kHz Switching Frequency
- Trickle Current / Constant Current / Constant Voltage Charge Mode
- Adaptive input current limit
- Programmable Charging Timeout
- 4.35 and 4.2V selectable cell voltage
- Programmable (2A MAX) Constant Charge Current
- Input Voltage UVLO and Battery OVP
- Over Temperature Protection
- Output Short Circuit Protection
- Charge Status Indication
- Normal Synchronous Buck Operation when Battery Removed
- Compact package SO8E

Applications

- Cellular Telephones,
- PDA, MP3 Players, MP4 Players
- Digital Cameras
- Bluetooth Applications
- PSP Game Players, NDS Game Players
- Notebook

Typical Applications

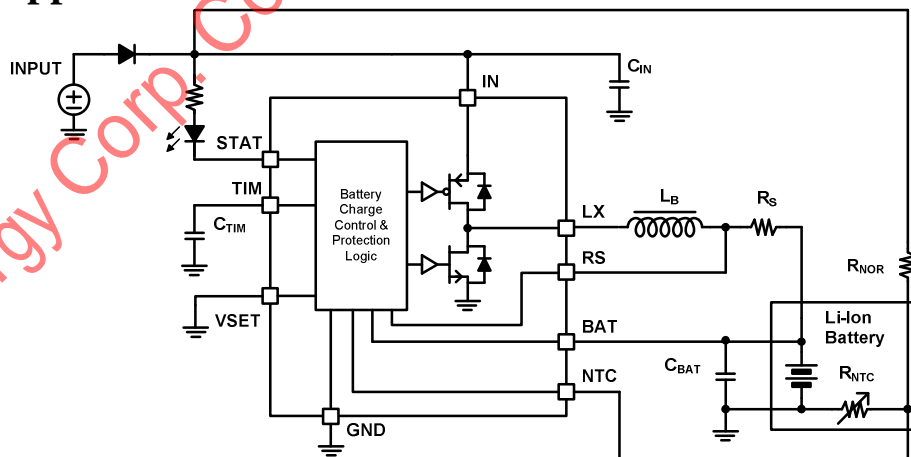
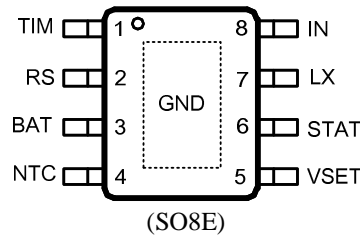

Figure1. Schematic Diagram

Pinout (top view)



Top Mark: ALBxyz (device code: **ALB**, *x*=year code, *y*=week code, *z*=lot number code)

Name	Number	Description
TIM	1	Charge time limit pin. Connect this pin with a capacitor to ground. Internal current source charge the capacitor for TC mode and CC mode's charge time limit. TC charge time limit is about 1/9 of CC charge time.
RS	2	Charge current program pin. Connect a current sense resistor from RS pin to BAT pin. Average charge current is detected for both TC mode and CC mode.
BAT	3	Battery positive pin.
NTC	4	Thermal protection pin. UTP threshold is about 75%V _{IN} and OTP threshold is about 30%V _{IN} . Pull up to VIN can disable charge logic and make the IC operate as normal buck regulator. Pull down to ground can shut down the IC.
VSET	5	VSET is pull down internally. Open or pull down for 4.2V cell voltage, pull up for 4.35V cell voltage.
STAT	6	Charge status indication pin. It is open drain output pin and can be used to turn on a LED to indicate the charge in process. When the charge is done, LED is off.
LX	7	Switch node pin. This pin connects the drains of the integrated main and synchronous power MOSFET switches. Connect to external inductor.
IN	8	Positive power supply input pin. V _{IN} ranges from 4V to 23V for normal operation. It has UVLO function and must be 300mV greater than the battery voltage to enable normal operation.
GND	Exposed pad	Ground pin.

Absolute Maximum Ratings (Note 1)

IN, BAT, RS, LX, -----	-0.5- 25V
VSET, TIM, NTC, STAT -----	-0.5- 25V
LX Pin current continuous -----	2A
Power Dissipation, Pd @ T _A = 25°C, SO8E-----	3.3W
Package Thermal Resistance	
θ _{JA} -----	30°C/W
θ _{JC} -----	20°C/W
Junction Temperature Range -----	-40°C to 150°C
Lead Temperature (Soldering, 10 sec.) -----	260°C
Storage Temperature Range -----	-65°C to 125°C
ESD Susceptibility (Note 2)	
HBM (Human Body Mode) -----	2kV
MM (Machine Mode) -----	200V

Recommended Operating Conditions

IN, BAT, RS, LX, -----	less than 23V
VSET, TIM, NTC, STAT -----	less than 23V
LX Pin current continuous -----	less than 1.5A
Junction Temperature Range -----	-20°C to 100°C
Ambient Temperature Range -----	-40°C to 85°C



AN_SY6952B

Electrical Characteristics

T_A=25°C, V_{IN}=15V, GND=0V, C_{IN}=10uF, L_B=6.8uH, R_S=25mΩ, C_{TIM}=330nF, unless otherwise specified.

Symbol	Parameter	Conditions	Min	Typ	Max	Unit
Bias Supply (V_{IN})						
V _{IN}	Supply voltage		4.0		23	V
V _{UVLO}	V _{IN} under voltage lockout threshold	V _{IN} rising and measured from V _{IN} to GND			3.9	V
ΔV _{UVLO}	V _{IN} under voltage lockout hysteresis	Measured from V _{IN} to GND		190		mV
V _{OV}	Input overvoltage protection	V _{IN} rising and measured from V _{IN} to GND	23			V
ΔV _{OV}	Input overvoltage protection hysteresis	Measured from V _{IN} to GND		750		mV
Quiescent Current						
I _{BAT}	Battery discharge current	Enable off			25	uA
I _{IN}	Input leakage current	Disable Charge			1.5	mA
Oscillator and PWM						
f _{OSC}	Oscillator frequency		640	800	960	kHz
D	PFET duty cycle				100	%
Power MOSFET						
R _{NFET}	R _{DS(ON)} of N-FET	Include bond-wire		150		mΩ
R _{PFET}	R _{DS(ON)} of P-FET			160		mΩ
Voltage Regulation						
V _{CV}	Low VSET for 4.2V cell voltage	0°C ≤ T _A ≤ 70°C	4.16	4.20	4.24	V
	High VSET for 4.35V cell voltage		4.30	4.35	4.40	
ΔV _{RCH}	4.2V CV threshold for Recharge	0°C ≤ T _A ≤ 70°C	50	100	150	mV
	4.35V CV threshold for Recharge		100	150	200	
V _{TRK}	TC charge mode voltage threshold	0°C ≤ T _A ≤ 70°C	2.2	2.5	2.8	V
Battery Connect Detection						
V _{DET}	Detect voltage threshold	V _{SHOT} < V _{BAT} < V _{RCH}	80%		90%	V _{IN}
t _{DET}	Detect delay time		30	35	40	ms
Charge Current						
	Internal charge current accuracy for Constant Current Mode	I _{CC} =25mV/R _S	-10%		10%	
	Internal charge current accuracy for Trickle Current Mode	I _{IC} =2.5mV/R _S	-50%		50%	
Input current limit slow response						
V _{INSL}	IN voltage falling threshold at high current			4.6		V
ΔV _{INSL}	IN voltage hysteresis at high current			50		mV
Input current limit quick response						
ΔV	IN voltage falling threshold at high current			4.4		V
ΔV _{INQK}	IN voltage hysteresis at high current			100		mV
Output Voltage OVP						
V _{OV}	Output voltage OVP threshold		105%	110%	115%	V _{CV}
Output Short Protection						
V _{SHOT}	Output short protection threshold	V _{BAT} falling edge	1.70	2.00	2.30	V
f _{FBK}	Frequency fold back	V _{BAT} < 2V/CELL		12.5%		f _{OSC}
I _{LM}	Power FET current limit			3.0		A
Timer						
T _{TC}	Trickle current charge timeout	C _{TIM} =330nF	0.23	0.5	0.67	hour
T _{CC}	Constant current charge timeout		3.0	4.5	6.0	hour
T _{MC}	Charge mode change delay time			30		ms
T _{TERM}	Termination delay time			30		ms
T _{RCHG}	Recharge time delay			30		ms
Battery Thermal Protection NTC						
UTP	Under temperature protection		70%	75%	80%	V _{IN}
	Under temperature protection hysteresis	Falling edge		5%		
OTP	Over temperature protection		28%	30%	32%	
	Over temperature protection hysteresis	Rising edge		2%		
Automatic Shutdown						
ΔV _{ASD}	ASD voltage threshold hysteresis	Measured from V _{IN} to V _{BAT}		80		mV
Thermal Shutdown						
T _{SD}	Thermal shutdown temperature	Rising Threshold		160		°C
T _{SDHYS}	Thermal shutdown temperature hysteresis			20		°C



Note 1: Stresses beyond the “Absolute Maximum Ratings” may cause permanent damage to the device. These are stress ratings only. Functional operation of the device at these or any other conditions beyond those indicated in the operational sections of the specification is not implied. Exposure to absolute maximum rating conditions for extended periods may affect device reliability.

Note 2: θ_{JA} is measured in the natural convection at $T_A = 25^\circ\text{C}$ on a low effective four-layer thermal conductivity test board of JEDEC 51-3 thermal measurement standard.

Note 3: The device is not guaranteed to function outside its operating conditions

Silergy Corp. Confidential-Prepared for PAX

Basic Li-Ion Battery Charge Operation Flow Chart

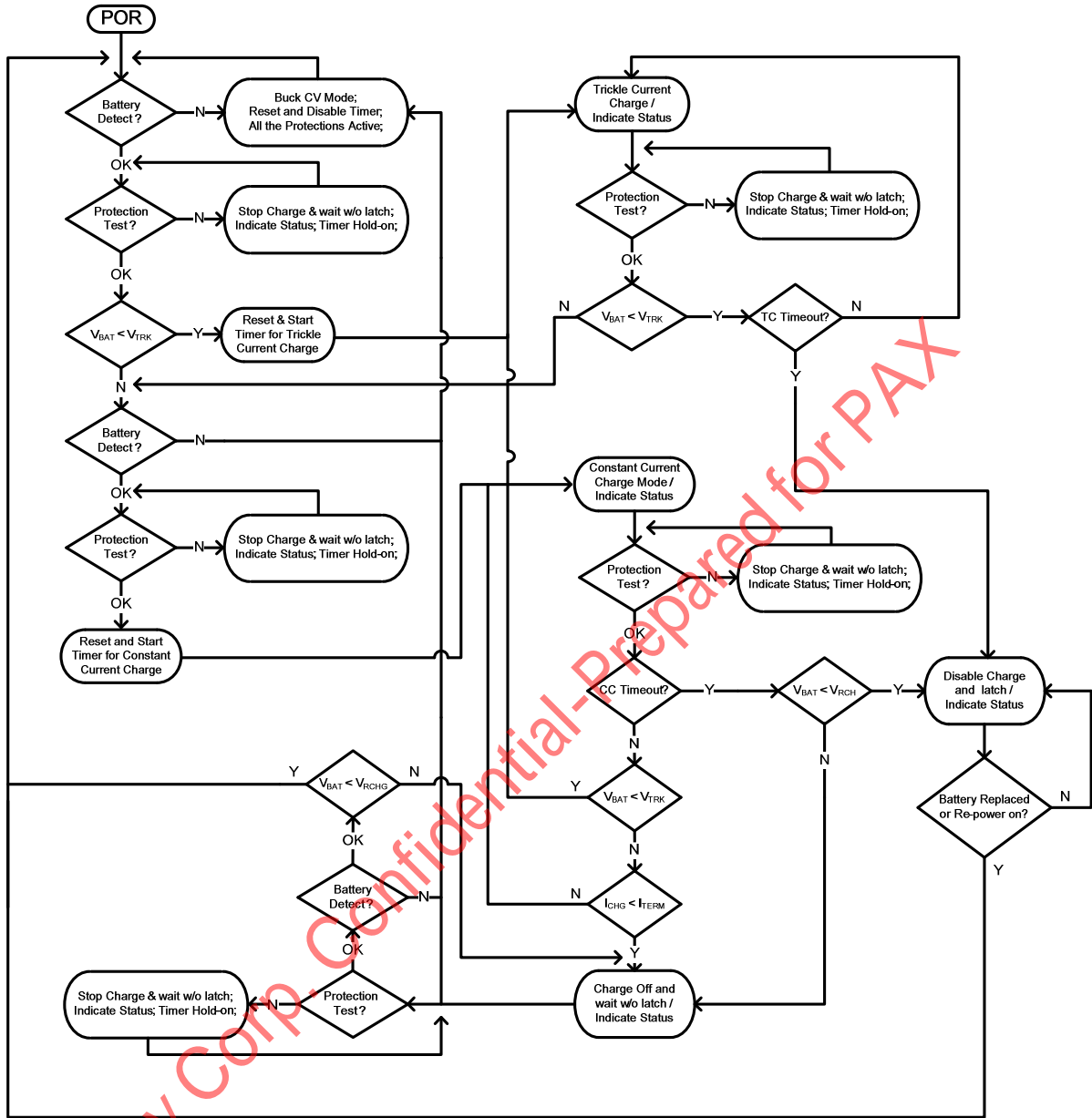



General Function Description

SY6952B is a 4.0-23V input, 2A single-cell synchronous Buck Li-Ion battery charger. The compact package SO8E is widely suitable for portable application. VSET pin is convenient for selecting 4.35V or 4.2V cell voltage. Integrated 800 kHz synchronous buck regulator consists of 23V rating FETs with extremely low ON resistance to achieve high charge efficiency and simple peripheral circuit design.

Charging Status Indication Description

1. **Charge-In-Process** – Pulls and keeps STAT pin to Low;
2. **Charge Done** – Pulls and keeps STAT pin to High;
3. **Fault Mode** – Outputs high and low voltage alternatively with 0.5Hz frequency when the C_{TIM} is 330nF.

Connects a LED from VIN to STAT pin, LED ON means Charge-in-Process, LED OFF means Charge Done, LED Flash means Fault Mode.

Buck Regulator Operation Description

If the Li-Ion battery is absent suddenly, the output battery load current drawn from BAT pin pulls down the voltage across the C_{BAT} until reaching the recharge threshold 4V. Then, SY6952B can operate as a normal peak current mode controlled synchronous buck converter and the output voltage on BAT pin is regulated at V_{CV} . In this operation mode, the input current limit and the constant output current loop are still active, however the charge timeout and the trickle current charge are disabled both.

Protection Description

Thermal Protection-Thermal shutdown is active for battery and IC both. IC recovers to normal work when the temperature backs in normal range again. Timer stop and hold-on without reset.

Short Circuit Protection- When VBAT voltage is lower than the short circuit protection threshold, short circuit protection is active. The switching frequency is fold back to 12.5% of the default value and VC begins to re-soft start periodically. During this mode, if the battery exists, the trickle charge timer is still active and would timeout the IC finally.

Over Current Protection- The internal current loop with different constant current capability is always active no matter in Buck mode or Battery Charging mode for the over current protection.

Over Voltage Protection- When VBAT voltage is higher than the over voltage protection threshold no matter with or without battery connecting, IC shuts down and recovers to normal work when VBAT backs to normal level. Input voltage has UVLO and OVP, which would make IC shutdown and recover to normal work when the VIN backs to normal range.

Adaptive Input Current Limit- When the input is drawn from a USB port, SY6952B will adaptively limit the current if the input current is over the USB supply capability.

Timeout Protection-Programmable timeout protection is for both Trickle Current Charge Mode and Constant Current Charge Mode. Once timeout is active, IC stops the charge operation and latches off. Only power or battery re-plug in can get the latch logic reset and the IC restarted.

Typical Performance Characteristics

$T_A=25^{\circ}\text{C}$, $V_{IN}=5\text{V}$, $R_S=20\text{m}\Omega$, 1cell battery, unless otherwise specified.

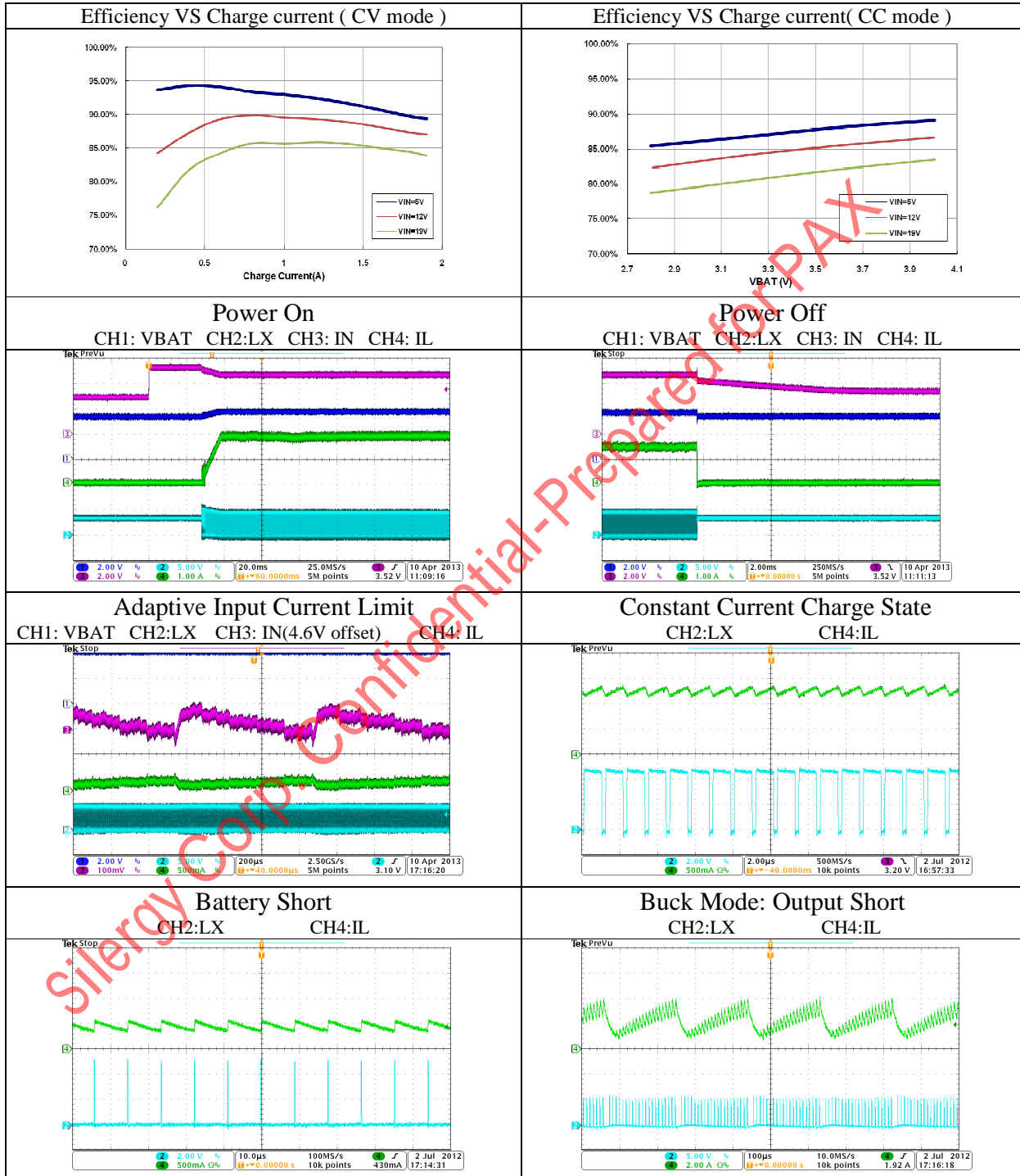

Applications Information

Because of the high integration of SY6952B, the application circuit based on this regulator IC is rather simple. Only input capacitor C_{IN} , output capacitor C_{OUT} , inductor L, NTC resistors R1,R2 ,charge current sense resistor R_s and timer capacitor C_{TIM} need to be selected for the targeted applications specifications.

NTC resistor:

SY6952B monitors battery temperature by measuring the input voltage and NTC voltage. The controller triggers the UTP or OTP when the rate K ($K = V_{NTC}/V_{IN}$) reaches the threshold of UTP (K_{UT}) or OTP (K_{OT}). The temperature sensing network is showed as below.

Choose R1 and R2 to program the proper UTP and OTP points.

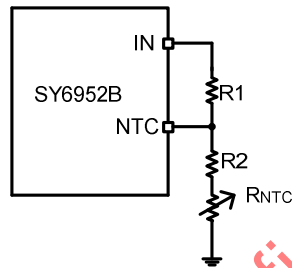

The calculation steps are:

1. Define K_{UT} , $K_{UT} = 70\sim 80\%$
2. Define K_{OT} , $K_{OT} = 28\sim 32\%$
3. Assume the resistance of the battery NTC thermistor is R_{UT} at UTP threshold and R_{OT} at OTP threshold.

4. Calculate R2,

$$R2 = \frac{K_{OT}(1 - K_{UT})R_{UT} - K_{UT}(1 - K_{OT})R_{OT}}{K_{UT} - K_{OT}}$$

5. Calculate R1

$$R1 = (1 / K_{OT} - 1)(R2 + R_{OT})$$

If choose the typical values $K_{UT} = 75\%$ and $K_{OT} = 30\%$, then

$$R2 = 0.17R_{UT} - 1.17R_{OT}$$

$$R1 = 2.3(R2 + R_{OT})$$

Charge current sense resistor R_s

The charge current sense resistor R_s is calculated as below:

$$R_s = \frac{25}{I_{CHG}}, \quad \text{Unit: mohm}$$

While the I_{CHG} is the battery constant charge current.

Timer capacitor C_{TIM}

The charger also provides a programmable charge timer. The charge time is programmed by the capacitor connected between the TIM pin and GND. The capacitance is given by the formula:

$$C_{TIM} = 2 * 10^{-11} T_{CC} \quad \text{Unit: F}$$

T_{CC} is the target constant charge time, measured in seconds.

Input capacitor C_{IN} :

The ripple current through input capacitor is greater than

$$I_{CIN_MIN} = I_{CHG} \sqrt{D(1-D)}$$

To minimize the potential noise problem, place a typical X7R or better grade ceramic capacitor really close to the IN and GND pins. Care should be taken to minimize the loop area formed by C_{IN} , and IN/GND pins.

Output capacitor C_{OUT} :

The output capacitor is selected to handle the output ripple noise requirements. Both steady state ripple and transient requirements must be taken into consideration when selecting this capacitor. For the best performance, it is recommended to use X7R or better grade ceramic capacitor with 10uF capacitance.

Output inductor L:

There are several considerations in choosing this inductor.

- 1) Choose the inductance to provide the desired ripple current. It is suggested to choose the ripple current to be about 40% of the average input current. The inductance is calculated as:



$$L = \frac{V_{OUT}(1 - V_{OUT}/V_{IN, MAX})}{F_{SW} \times I_{OUT, MAX} \times 40\%}$$

Where F_{SW} is the switching frequency and $I_{OUT, MAX}$ is the maximum load current.

The SY6952B regulator IC is quite tolerant of different ripple current amplitude. Consequently, the final choice of inductance can be slightly off the calculation value without significantly impacting the performance.

- 2) The saturation current rating of the inductor must be selected to be greater than the peak inductor current under full load conditions.

$$I_{SAT, MIN} > I_{OUT, MAX} + \frac{V_{OUT}(1 - V_{OUT}/V_{IN, MAX})}{2 \times F_{SW} \times L}$$

- 3) The DCR of the inductor and the core loss at the switching frequency must be low enough to achieve the desired efficiency requirement. It is desirable to choose an inductor with $DCR < 10\text{mohm}$ to achieve a good overall efficiency.

Layout Design:

The layout design of SY6952B regulator is relatively simple. For the best efficiency and minimum noise problems, we should place the following components close to the IC: C_{IN} , L, R_1 and R_2 .

- 1) It is desirable to maximize the PCB copper area connecting to GND pin to achieve the best thermal and noise performance. If the board space allowed, a ground plane is highly desirable.

- 2) C_{IN} must be close to Pins IN and GND. The loop area formed by C_{IN} and GND must be minimized.

- 3) The PCB copper area associated with LX pin must be minimized to avoid the potential noise problem.

- 4) The capacitor C_{TM} and the trace connecting to the TIM pin must NOT be adjacent to the LX net on the PCB layout to avoid the noise problem. It should be better to ground C_{TM} to the output Capacitor's ground.

SO8E Package outline & PCB layout design

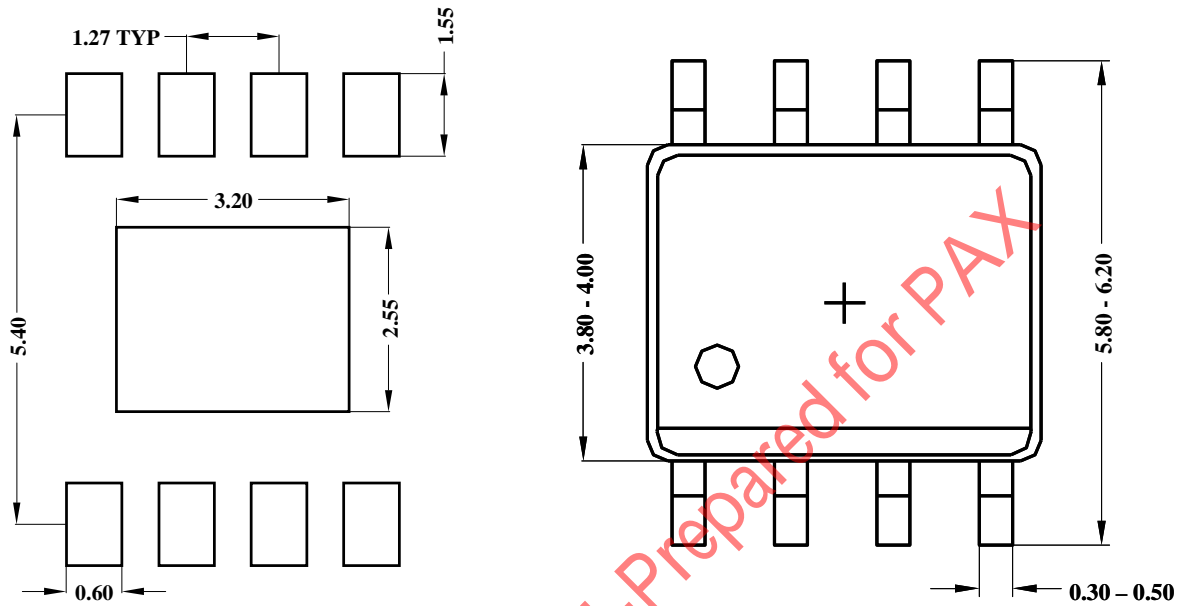

Recommended Pad Layout

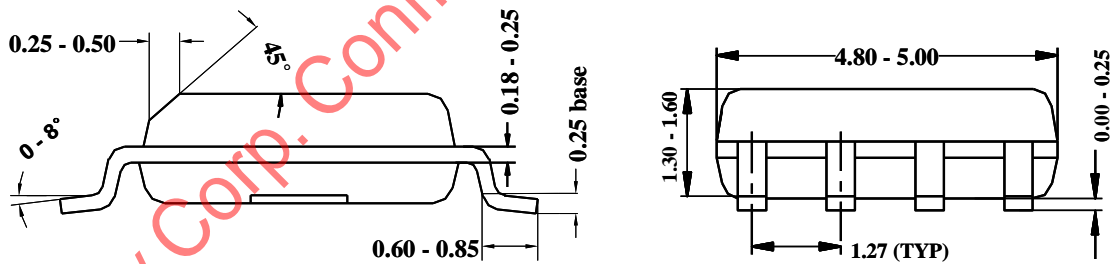

Notes: All dimensions are in millimeters.
All dimensions don't include mold flash & metal burr.

Taping & Reel Specification

1. Taping orientation

SO8E

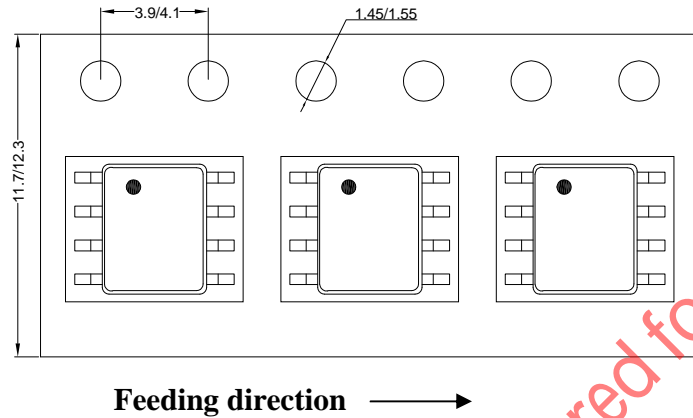

2. Carrier Tape & Reel specification for packages

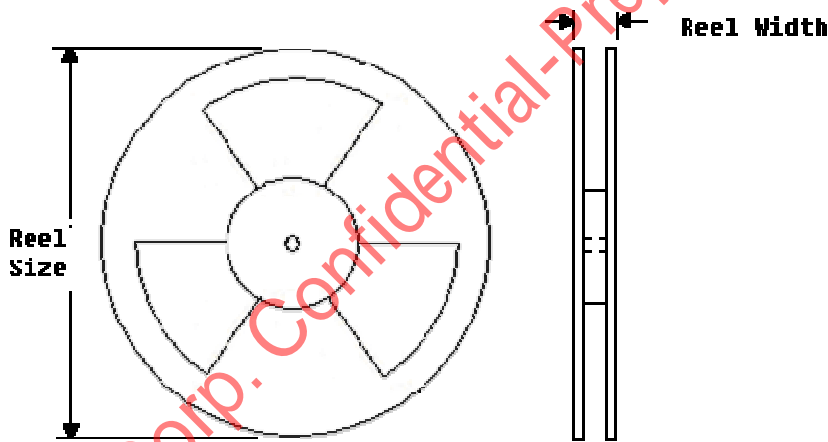

Package types	Tape width (mm)	Pocket pitch(mm)	Reel size (Inch)	Reel width(mm)	Trailer length(mm)	Leader length (mm)	Qty per reel
SO8E	12	8	13"	12.4	400	400	2500

3. Others: NA