



Application Note: SY6981

High Efficiency, 1.2A

Two-cell Boost Li-Ion Battery Charger

General Description

SY6981 is a 3.6-5.5V_{IN}, 1.2A two-cell synchronous Boost Li-Ion battery charger which integrates 1MHz switching frequency and full protection functions. The charge current up to 1.2A can be programmed by using the external resistor for different portable applications and indicates the charger current information simultaneously. It also has a programmable charge timeout for safety battery charge operation and a programmable input voltage threshold for adaptive input current limit. SY6981 can disconnect output when there is an output short circuit or shutdown. It consists of 18V rating FETs with extremely low on resistance to achieve high charge efficiency and simple peripheral circuit design.

SY6981 along with small QFN3×3 footprint provides small PCB area application.

Ordering Information

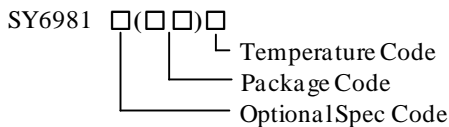

| Ordering Number | Package type | Note |
|-----------------|--------------|------|
| SY6981QDC | QFN3×3-16 | |

Features

- Low Profile QFN3×3 Package
- Integrated Synchronous Boost with 18V Rating Low R_{DS(on)} FETs for High Charge Efficiency
- Trickle Current / Constant Current / Constant Voltage Charge Mode
- Programmable Input Voltage Threshold for Adaptive Current Limit.
- Maximum 1.2A Constant Charge Current
- Charge Current Information Indication.
- Programmable Charge Timeout
- Programmable Constant Charge Current
- Selectable Constant Voltage
- ±0.5% Battery Voltage Accuracy
- Thermal Regulation Protection
- External Shutdown Function
- Input Voltage UVLO and OVP
- Over Temperature Protection
- Output Short Circuit Protection
- Charge Status Indication
- Normal Synchronous Boost Operation When the Battery is Removed

Applications

- Cellular Telephones, PDA, MP3 Players, MP4 Players
- Digital Cameras
- Bluetooth Applications
- PSP Game Players, NDS Game Players
- Notebook

Typical Applications

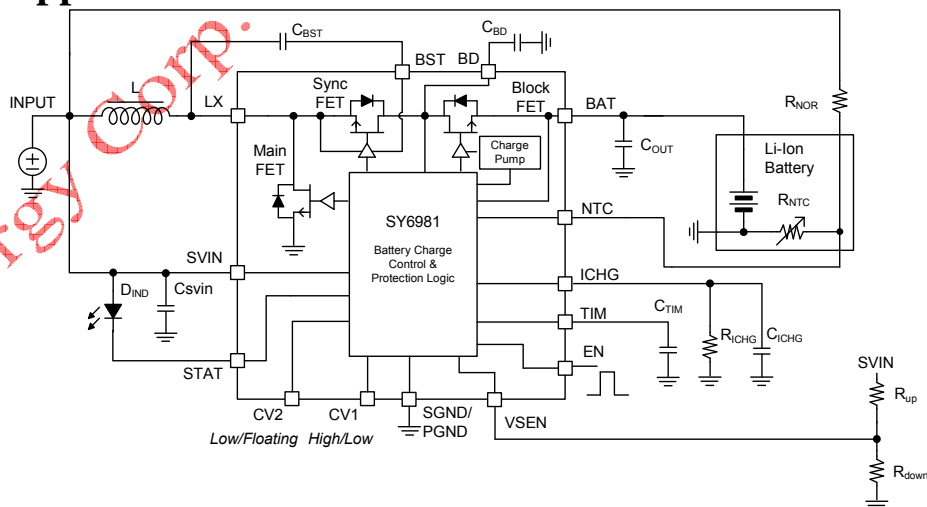
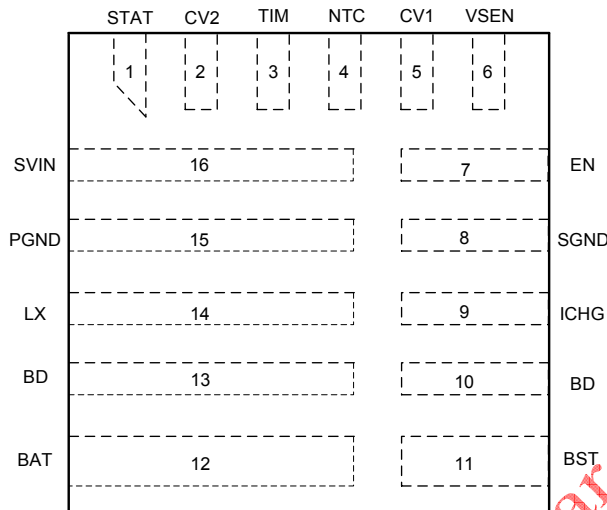

Figure1. Schematic Diagram

Pinout (top view)

(QFN3×3-16)

 Top Mark: **cRxyz**, (Device code: cR, *x*=year code, *y*=week code, *z*=lot number code)

| Name | Pin Number | Description |
|------|------------|---|
| STAT | 1 | Charge status indication pin. It is open-drain output pin and pulled high to SVIN through a LED to indicate the charge in process. When the charge is done, the LED will be off. |
| CV2 | 2 | Battery CV voltage selection pin. Program 4 different CV thresholds by setting different voltage on this pin and pin5. Floating or grounding this pin in the application. CV2 pin can't be pulled high to any bias voltage higher than 3.3V. |
| TIM | 3 | Charge time limit pin. Connect this pin with a capacitor to ground. Internal current source charge the capacitor for TC mode and CC mode's charge time limit. TC charge time limit is about 1/9 of CC charge time. |
| NTC | 4 | Thermal protection pin. UTP threshold is typical 76% of V_{SVIN} and OTP threshold is typical 30.5% of V_{SVIN} . Pull up to SVIN can disable charge logic and make the IC operate as a normal Boost regulator. Pull down to ground can shut down the IC. |
| CV1 | 5 | Battery CV voltage selection pin. Program 4 different CV thresholds by setting different voltage on this pin and pin2. The detailed information is shown in description section. |
| VSEN | 6 | Voltage sense of SVIN. If the voltage drops to internal 1.195V reference voltage, the SVIN will be clamped to setting value and input current will be limited. |
| EN | 7 | Enable control pin. High logic for enable on, and low logic for enable off. |
| SGND | 8 | Signal ground pin. |
| ICHG | 9 | Charge current program pin. Pull down to GND with a resistor R_{ICHG} . The mirror current about 1/10000 of the blocking FET current will dump into the external RC network through ICHG pin and compared to the internal reference 1V. So $I_{CC} = (1V / R_{ICHG}) \times 10000$, $I_{TC} = (1V / R_{ICHG}) \times 1000 + 0.02$. |
| BD | 10, 13 | Connect it to the drain of internal blocking FET. Bypass at least a 4.7 μ F ceramic cap to GND. |
| BST | 11 | Boost-strap pin. Supply rectified FET's gate driver. Decouple this pin to LX with a 0.1 μ F ceramic cap. |
| BAT | 12 | Battery positive pin. |
| LX | 14 | Switch node pin. Connect it to the external inductor. |
| PGND | 15 | Power ground pin. |
| SVIN | 16 | Analog power input pin. Connect a MLCC from this pin to ground to decouple high harmonic noise. This pin has OVP and UVLO function to make the charger operate within safe input voltage range. |



Absolute Maximum Ratings (Note1)

| | |
|---|----------------|
| STAT, NTC, CV1, VSEN, EN, ICHG, BD, BAT, LX, SVIN | 18V |
| CV2, TIM, BST-LX | 4V |
| LX Pin Continuous Current | 5A |
| Power Dissipation, P _D @ T _A = 25°C, QFN3×3 | 2.6W |
| Package Thermal Resistance (Note2) | |
| θ _{JA} | 38°C/W |
| θ _{JC} | 4°C/W |
| Junction Temperature Range | -40°C to 125°C |
| Lead Temperature (Soldering, 10 sec.) | 260°C |
| Storage Temperature Range | -65°C to 125°C |

Recommended Operating Conditions (Note3)

| | |
|--|----------------|
| SVIN | 3.6V to 5.5V |
| STAT, NTC, CV1, VSEN, EN, ICHG, BD, BAT, LX, | -0.3V to 16V |
| CV2, TIM, BST-LX | -0.3V to 3.3V |
| LX Pin Continuous Current | 5A |
| Junction Temperature Range | -40°C to 125°C |
| Ambient Temperature Range | -40°C to 85°C |

Silergy Corp. Confidential Prepared for YuCen



Electrical Characteristics

T_A=25°C, V_{IN}=5V, GND=0V, C_{IN}=4.7μF, L=0.68μH, R_{ICHG}=10kΩ, C_{TIM}=470nF, unless otherwise specified.

| Parameter | Symbol | Conditions | Min | Typ | Max | Unit |
|---|----------------------|---|-------|------|-------|------|
| Bias Supply (V_{SVIN}) | | | | | | |
| Supply Voltage | V _{SVIN} | | 3.6 | | 16 | V |
| V _{SVIN} Under Voltage Lockout Threshold | V _{UVLO} | V _{SVIN} rising and measured from V _{SVIN} to GND | | | 3.6 | V |
| V _{SVIN} Under Voltage Lockout Hysteresis | ΔV _{UVLO} | Measured from V _{SVIN} to GND | | 100 | | mV |
| Input Over Voltage Protection | V _{OVV} | V _{SVIN} rising and measured from V _{SVIN} to GND | 5.8 | | | V |
| Input Over Voltage Protection Hysteresis | ΔV _{OVV} | Measured from V _{SVIN} to GND | | 0.5 | | V |
| Quiescent Current | | | | | | |
| Battery Discharge Current | I _{BAT} | Shut down IC, EN=NTC=0 | | | 10 | μA |
| Input Quiescent Current | I _{IN} | Disable charge, EN=1,NTC=0 | | | 1.5 | mA |
| Oscillator and PWM | | | | | | |
| Switching Frequency | f _{SW} | | | 1000 | | kHz |
| Main N-FET Minimum Off Time | t _{MIN_OFF} | With 18V rating | | 100 | | ns |
| Main N-FET Maximum Off Time | t _{MAX_OFF} | With 18V rating | | 30 | | μs |
| Main N-FET Minimum On Time | t _{MIN_ON} | With 18V rating | | 100 | | ns |
| Power MOSFET | | | | | | |
| R _{DS(ON)} of Main N-FET | R _{NFET_M} | | | 100 | | mΩ |
| R _{DS(ON)} of Rectified N-FET | R _{NFET_R} | | | 50 | | mΩ |
| R _{DS(ON)} of Blocking N-FET | R _{NFET_B} | | | 50 | | mΩ |
| Voltage Regulation | | | | | | |
| Battery Charge Voltage | V _{BAT_REG} | V _{CV1} >1.5V, V _{CV2} is floating | 8.159 | 8.2 | 8.241 | V |
| | | V _{CV1} <0.4V, V _{CV2} is floating | 8.358 | 8.4 | 8.442 | |
| | | V _{CV1} >1.5V, V _{CV2} <0.4V | 8.656 | 8.7 | 8.743 | |
| | | V _{CV1} <0.4V, V _{CV2} <0.4V | 8.756 | 8.8 | 8.844 | |
| High Level Logic for CV1 | V _{CV_H} | | 1.5 | | | V |
| Low Level Logic for CV1,CV2 | V _{CV_L} | | | | 0.4 | V |
| Recharge Threshold Refer to V _{BAT_REG} | ΔV _{RCH} | | 100 | 200 | 300 | mV |
| Trickle Current Charge Mode Battery Voltage Threshold | V _{TRK} | Rising edge threshold | 5.4 | 5.6 | 5.8 | V |



| Battery Connect Detection | | | | | | |
|---|---------------------|---------------------------------|-------|-------|-------|----------------|
| NTC Voltage Threshold for Battery Detect | V_{DET} | NTC Falling Edge | 85% | | 95% | V_{SVIN} |
| Detect Delay Time | t_{DET} | | | 30 | | ms |
| Charge Current | | | | | | |
| Internal Charge Current Accuracy for Constant Current Mode | | $I_{CC}=1000mA$ | -10 | | 10 | % |
| Internal Charge Current Accuracy for Trickle Current Mode | | $I_{TC}=120mA$ | -50 | | 50 | % |
| Termination Current | I_{TERM} | $I_{CC}=1000mA$ | 50 | 100 | 150 | mA |
| Output Voltage OVP | | | | | | |
| Output Voltage OVP Threshold | V_{OVP} | | 105% | 110% | 115% | V_{BAT_REG} |
| Input Voltage Threshold for Adaptive Current Limit | | | | | | |
| Voltage Reference of VSEN | V_{SEN} | | 1.17 | 1.195 | 1.22 | V |
| Timer | | | | | | |
| Trickle Current Charge Timeout | t_{TC} | $C_{TIM}=330nF$ | 0.4 | 0.5 | 0.65 | hour |
| Constant Current Charge Timeout | t_{CC} | | 3.8 | 4.5 | 5.82 | hour |
| Charge Mode Change Delay Time | t_{MC} | | | 30 | | ms |
| Termination Delay Time | t_{TERM} | | | 30 | | ms |
| Recharge Time Delay | t_{RCHG} | | | 30 | | ms |
| Short Circuit Protection | | | | | | |
| Output Short Protection Threshold | V_{SHORT} | | 1.70 | 2.00 | 2.30 | V |
| Linear Charger Mode | | | | | | |
| Battery Charger Current When the Blocking FET is in Linear Mode | I_{SC} | $V_{BAT} < V_{SHORT}$ | 4% | 10% | | I_{CC} |
| BD Voltage Regulation | V_{BD} | $V_{SHORT} < V_{BAT} < V_{TRK}$ | 5.8 | 6 | 6.2 | V |
| Enable ON/OFF Control | | | | | | |
| High Level Logic for Enable Control | V_{EN_H} | | 1.5 | | | V |
| Low Level Logic for Enable Control | V_{EN_L} | | | | 0.4 | V |
| Battery Thermal Protection NTC | | | | | | |
| Under Temperature Protection | V_{NTC_UTP} | | 75% | 76% | 77% | V_{SVIN} |
| Under Temperature Protection Hysteresis | $V_{NTC_UTP_HYS}$ | Falling edge | | 6% | | |
| Over Temperature Protection | V_{NTC_OTP} | | 29.5% | 30.5% | 31.5% | |
| Over Temperature Protection Hysteresis | $V_{NTC_OTP_HYS}$ | Rising edge | | 2% | | |
| Thermal Fold-back and Thermal Shutdown | | | | | | |
| Thermal Fold-back Threshold | T_{Fold} | Rising edge | | 120 | | °C |
| Thermal Fold-back Threshold Hysteresis | T_{Fold_HYS} | | | 20 | | °C |
| Thermal Fold-back Ratio | | | | 0.25 | | I_{CC} |
| Thermal Shutdown Temperature | T_{SD} | Rising edge | | 160 | | °C |
| Thermal Shutdown Temperature Hysteresis | T_{SD_HYS} | | | 30 | | °C |

Note 1: Stresses beyond the “Absolute Maximum Ratings” may cause permanent damage to the device. These are stress ratings only. Functional operation of the device at these or any other conditions beyond those indicated in the



operational sections of the specification is not implied. Exposure to absolute maximum rating conditions for extended periods may affect device reliability.

Note 2: θ_{JA} is measured in the natural convection at $T_A = 25^\circ\text{C}$ on a low effective four-layer thermal conductivity test board of JEDEC 51-3 thermal measurement standard.

Note 3: The device is not guaranteed to function outside its operating conditions.

Silergy Corp. Confidential Prepared for Yucan

Typical Performance Characteristics

($T_A=25^\circ\text{C}$, $V_{IN}=5\text{V}$, $R_{ICHG}=10\text{k}\Omega$, unless otherwise specified.)

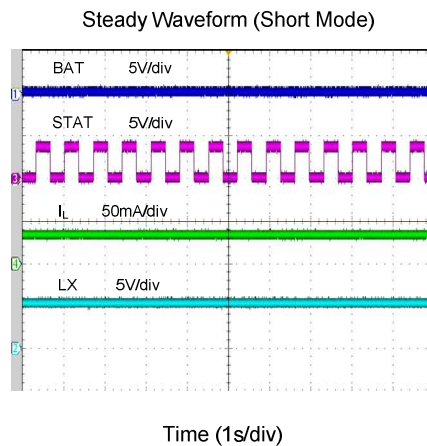
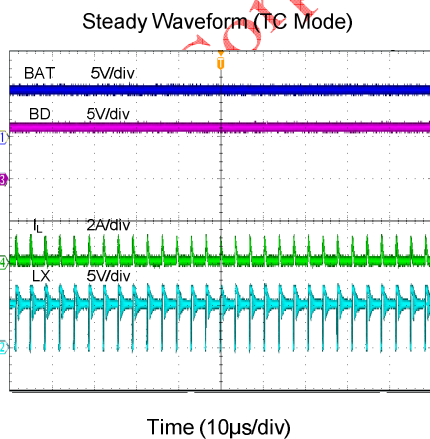
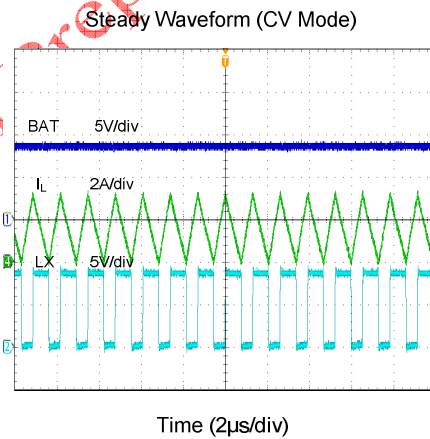
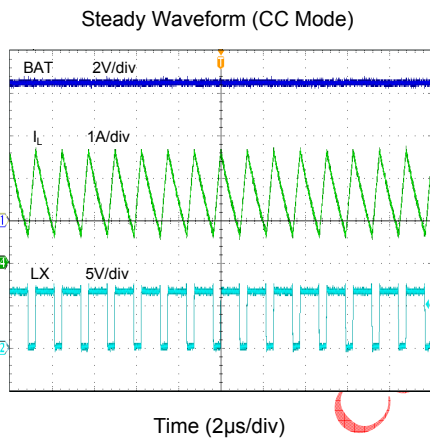
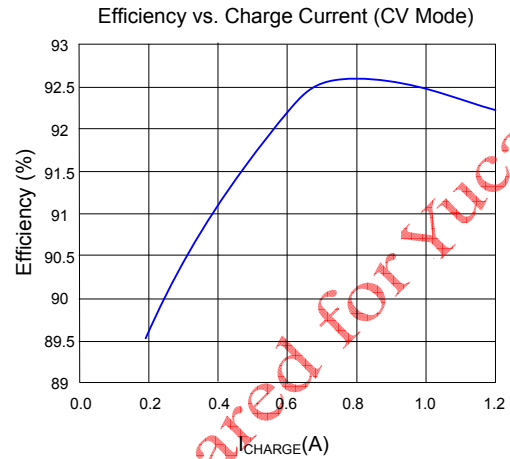
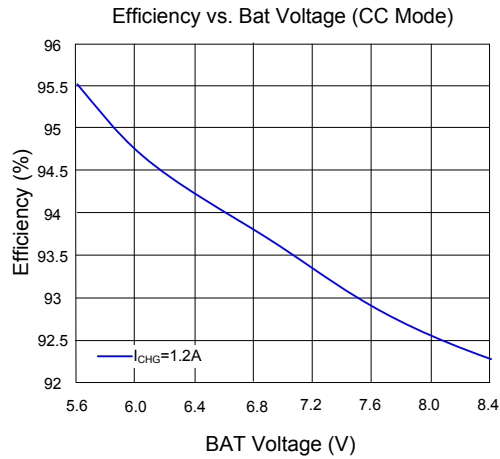

Power ON (CC Mode)

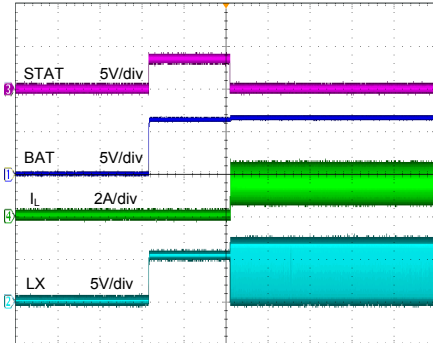

Time (400ms/div)

Power OFF (CC Mode)

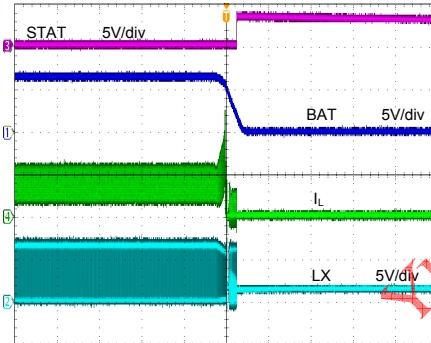

Time (2ms/div)

Power ON (CV Mode)

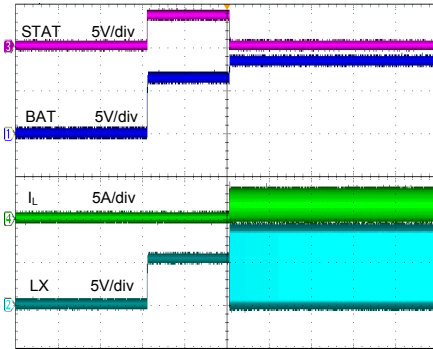

Time (400ms/div)

Power OFF (CV Mode)

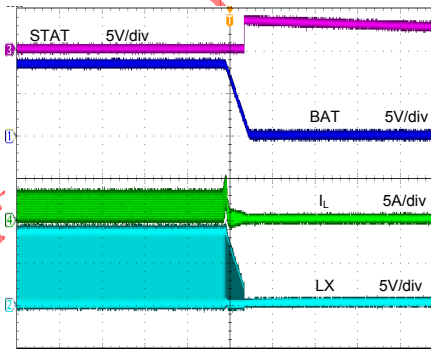

Time (4ms/div)

Adaptive Input Current Limit
(5V/1A Adapter)

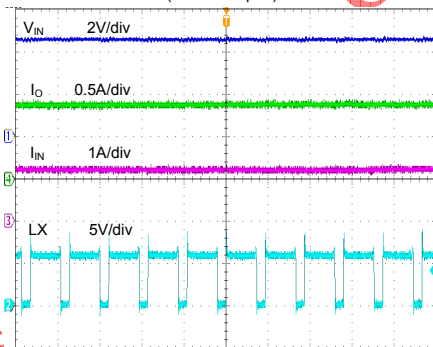

Time (1μs/div)

Boost Mode (Null load)

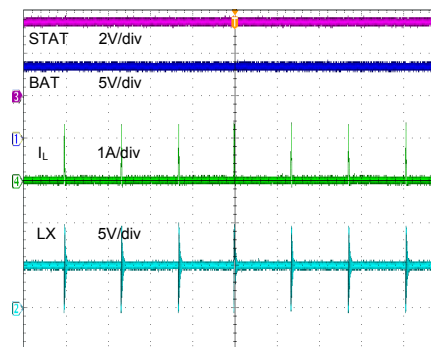

Time (20μs/div)



General Function Description

SY6981 is a 3.6-5.5V_{IN}, 1.2A two-cell synchronous Boost Li-Ion battery charger which integrates 1MHz switching frequency and full protection functions. The charge current up to 1.2A can be programmed by using the external resistor for different portable applications and indicates the charger current information simultaneously. It also has a programmable charge timeout for safety battery charge operation and a programmable input voltage threshold for adaptive input current limit. SY6981 can disconnect output when there is an output short circuit or shutdown. It consists of 18V rating FETs with extremely low on resistance to achieve high charge efficiency and simple peripheral circuit design.

Charging Status Indication Description

1. Charge-in-process – Pull and keep STAT pin low;
2. Charge Done – Pull and keep STAT pin high;
3. Fault Mode – Output high and low voltage alternatively at the frequency of 1.3Hz. Connect a LED from SVIN to STAT pin, LED on means charge-in-process, LED off means charge done, LED flashing at 1.3Hz means fault mode. Fault Mode includes Input OVP, BAT OVP, BAT Short Circuit, NTC(UTP/OTP), Thermal Shutdown and Charge Timeout.

Switching Mode Boost Charger Basic Operation Description

Switching Mode Control Strategy

SY6981 is a switching mode Boost charger for the applications with USB power input. The 1MHz fixed frequency is easy for the size minimization of peripheral circuit design.

Operation Principle

SY6981 can normally work with or without Li-Ion battery.

Battery Present

When the battery is present, SY6981 will work on trickle current charge, constant current charge and constant voltage charge mode according to the battery voltage.

Battery Absent

If there's no battery connection detected through NTC pin, SY6981 will operate as a normal switching mode Boost converter. The internal constant current

loop and voltage loop are active both.

Basic Protection Principle

SY6981 has fully battery charging protection. When the input over voltage protection, the output over voltage protection, the thermal protection or the timeout protection happens, the Boost charger will stop switching immediately. When the V_{BAT} is lower than V_{SHORT}, the short circuit protection will happen. The main FET will be turned off firstly. The block FET will enter linear mode with 1/10 of I_{CH} charging current. When V_{BAT} returns to be higher than V_{SHORT}, the Boost charger will restart to work at light load and regulate V_{BD} at 6V. The linear charge current will keep 1/10 I_{CC}. When V_{BAT} returns to be higher than V_{TRK}, the Boost switching charger will take over.

Adaptive Input Current Limit Principle

SY6981 can protect the input DC source from over load by the special loop control. The high charging current will cause a voltage drop at SVIN when the input DC source is over load. When VSEN drops below the internal 1.195V reference, SY6981 will decrease the duty cycle to reduce the charging current.

Constant Voltage Threshold Program Principle

SY6981 can program the constant voltage threshold thru the CV1 and CV2. When V_{CV1} is higher than 1.5V and CV2 is floating, the constant voltage threshold is 8.2V; when V_{CV1} is lower than 0.4V and CV2 is floating, the constant voltage threshold is 8.4V; when V_{CV1} is high than 1.5V and V_{CV2} is lower than 0.4V, the constant voltage threshold is 8.7V; when V_{CV1} and V_{CV2} are lower than 0.4V both, the constant voltage threshold is 8.8V.

Applications Information

Because of the high integration of SY6981, the application circuit based on this regulator IC is rather simple. Only input capacitor C_{IN}, output capacitor C_{OUT}, inductor L, NTC resistors R1, R2, input voltage threshold resistors R_{UP}, R_{DOWN} and timer capacitor C_{TM} need to be selected for the target applications specifications.

NTC Resistor

SY6981 monitors battery temperature by measuring the input voltage and NTC voltage. The controller will trigger the UTP or OTP when the rate K (K = V_{NTC}/V_{SVIN}) reaches the threshold of UTP (K_{UT}) or OTP (K_{OT}). The temperature sensing network is showed as below.

Choose R1 and R2 to program the proper UTP and OTP points.

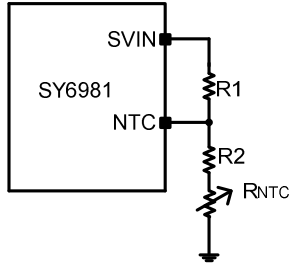

The calculation steps are:

1. Define K_{UT} , $K_{UT} = 75\sim 77\%$
2. Define K_{OT} , $K_{OT} = 29.5\sim 31.5\%$
3. Assume the resistance of the battery NTC thermistor is R_{UT} at UTP threshold and R_{OT} at OTP threshold.
4. Calculate R2,

$$R2 = \frac{K_{OT}(1-K_{UT})R_{UT} - K_{UT}(1-K_{OT})R_{OT}}{K_{UT} - K_{OT}}$$

5. Calculate R1

$$R1 = (1/K_{OT} - 1)(R2 + R_{OT})$$

If choose the typical values $K_{UT} = 76\%$ and $K_{OT} = 30.5\%$, then

$$R2 = 0.16R_{UT} - 1.16R_{OT}$$

$$R1 = 2.3(R2 + R_{OT})$$

Input Voltage Threshold for Adaptive Current

Limit

SY6981 will monitor input voltage by measuring the VSEN voltage, when VSEN drops below the internal 1.195V reference, SY6981 will decrease the duty cycle to reduce the charging current.

The input voltage sense network shows below, choose R_{UP} , R_{DOWN} to set the input voltage threshold V_{INT} :

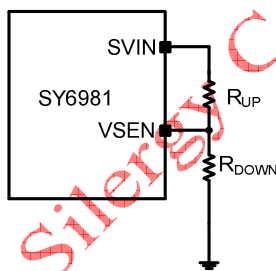

$$V_{INT} = \frac{V_{SEN} \times (R_{down} + R_{up})}{R_{down}} \quad \text{unit: V}$$

V_{SEN} is 1.195V.

Timer Capacitor C_{TIM}

The charger also provides a programmable charge timer. The charge time is programmed by the capacitor connected between the TIM pin and GND. The capacitance is given by the formula:

$$C_{TIM} = 2 \times 10^{-11} S \times T_{CC} \quad \text{unit: F}$$

T_{CC} is the target constant charge time, unit: s.

Input Capacitor C_{IN}

The ripple current through input capacitor is greater than

$$I_{C_{IN_RMS}} = \frac{V_{IN} \times (V_{OUT} - V_{IN})}{2\sqrt{3} \times L \times F_{SW} \times V_{OUT}}$$

X5R or X7R ceramic capacitors with greater than 4.7 μ F capacitance are recommended to handle this ripple current.

Output Capacitor C_{OUT}

The output capacitor is selected to handle the output ripple noise requirements. This ripple voltage is related to the capacitance and its equivalent series resistance (ESR). For the best performance, it is recommended to use X5R or a better grade low ESR ceramic capacitor. The voltage rating of the output capacitor should be higher than the maximum output voltage. The minimum required capacitance can be calculated as:

$$C_{OUT} = \frac{I_{CC} \times (V_{OUT} - V_{IN})}{F_{SW} \times V_{OUT} \times V_{RIPPLE}}$$

V_{RIPPLE} is the peak to peak output ripple, I_{CC} is the setting charge current.

For SY6981, output capacitor is paralleled by C_{BD} and C_{BAT} , for smaller output ripple noise, each capacitor with greater than 10 μ F capacitance is recommended.

Inductor L

There are several considerations in choosing this inductor.

- 1) Choose the inductance to provide the desired ripple current. It is suggested to choose the ripple current to be about 40% of the average input current. The inductance is calculated as:

$$L = \left(\frac{V_{IN}}{V_{OUT}} \right)^2 \frac{(V_{OUT} - V_{IN})}{I_{CC} \times F_{SW} \times 40\%}$$

Where F_{SW} is the switching frequency and I_{CC} is the setting charge current.

The SY6981 is quite tolerant of different ripple current amplitudes. Consequently, the final choice of inductance can be slightly off the calculation value without significantly impacting the performance.

- 2) The saturation current rating of the inductor must be selected to be greater than the peak inductor current under full load conditions.

$$I_{SAT,MIN} > \left(\frac{V_{OUT}}{V_{IN}}\right) \times I_{CC} + \left(\frac{V_{IN}}{V_{OUT}}\right) \times \frac{(V_{OUT} - V_{IN})}{2 \times F_{SW} \times L}$$

- 3) The DCR of the inductor and the core loss at the switching frequency must be low enough to achieve the desired efficiency requirement. It is desirable to choose an inductor with $DCR < 10\text{mohm}$ to achieve a good overall efficiency.

Layout Design

The layout design of SY6981 regulator is relatively simple. For the best efficiency and to minimize noise

problems, we should place the following components close to the IC: C_{SVIN} , L, C_{BD} .

- 1) The loop of main MOSFET, rectifier diode, and C_{BD} must be as short as possible
- 2) It is desirable to maximize the PCB copper area connected to GND pin to achieve the best thermal and noise performance.
- 3) C_{SVIN} must be close to pin SVIN and GND.
- 4) The PCB copper area associated with LX pin must be minimized to avoid the potential noise problem.
- 5) The small signal components, R_{ICRG} , R_{UP} and R_{DOWN} must be placed close to the IC and must not be adjacent to the LX net on the PCB layout to avoid the noise problem.

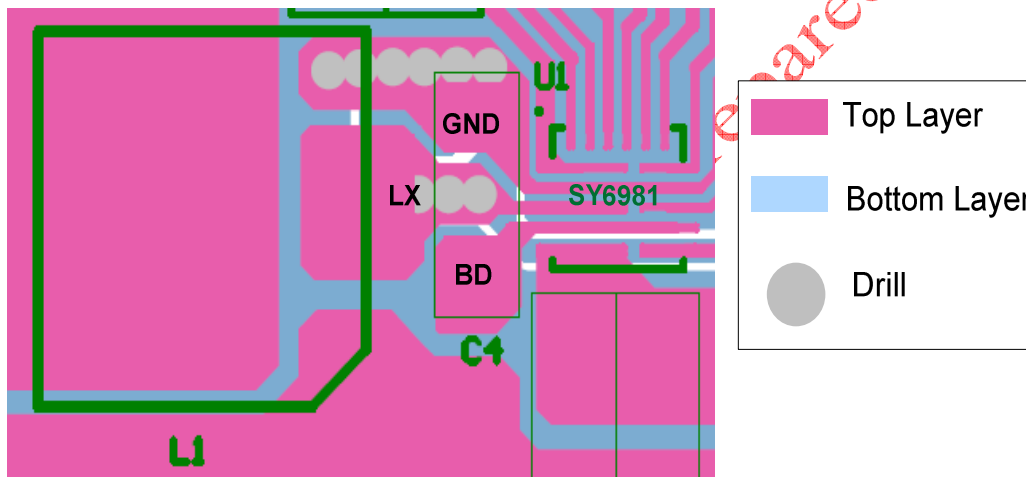
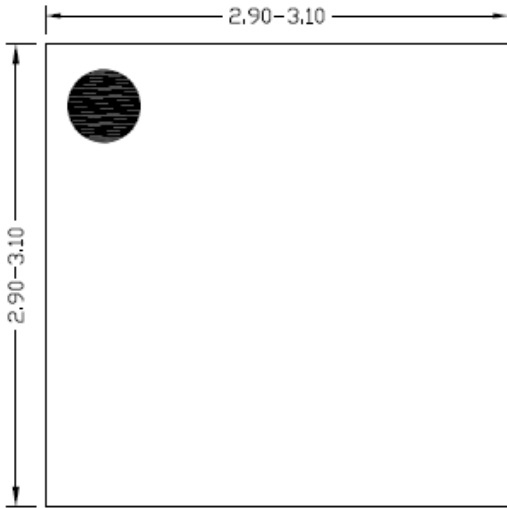
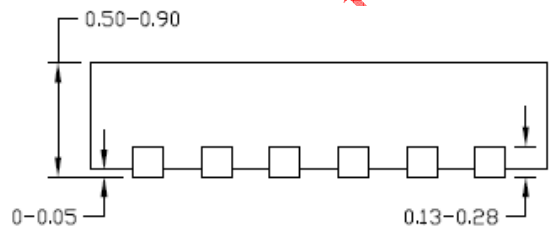

Figure2. PCB Layout Suggestion

QFN3×3-16 Package Outline Drawing



Top View



Side View

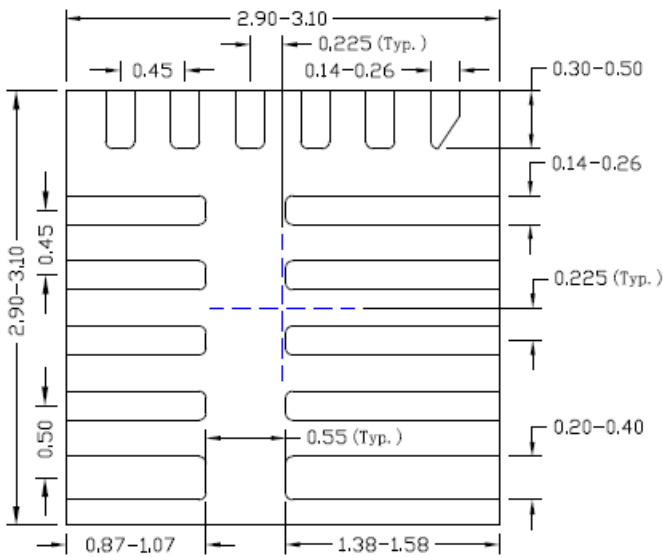

Bottom View

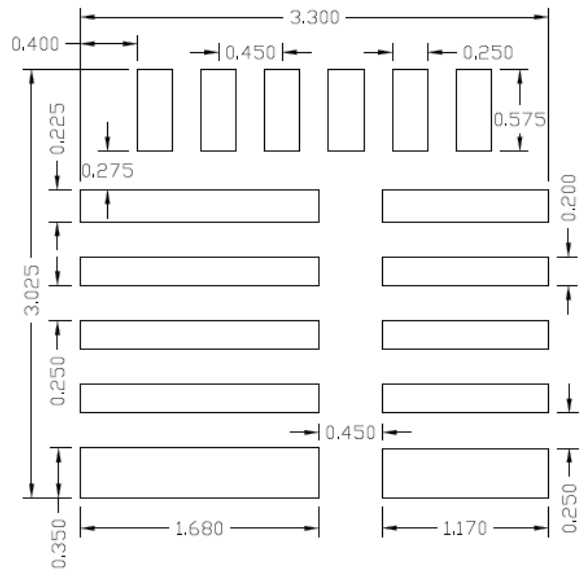

Recommended PCB layout
(Reference only)

Notes: All dimension in millimeter and exclude mold flash & metal burr.

Taping & Reel Specification

1. Taping orientation

QFN3×3

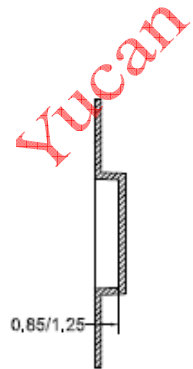
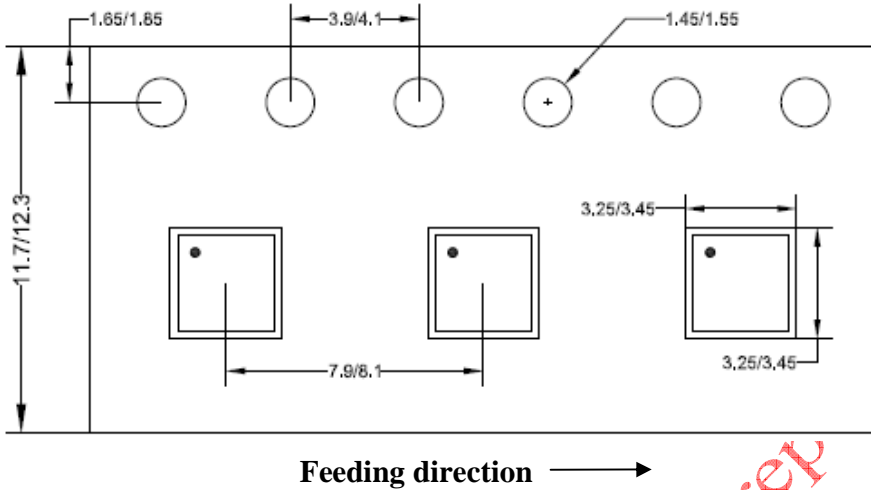

2. Carrier Tape & Reel specification for packages

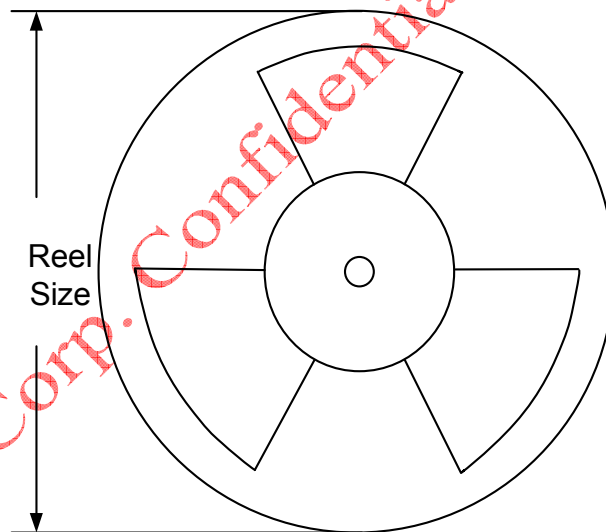

| Package type | Tape width (mm) | Pocket pitch (mm) | Reel size (Inch) | Trailer length (mm) | Leader length (mm) | Qty per reel |
|--------------|-----------------|-------------------|------------------|---------------------|--------------------|--------------|
| QFN3×3 | 12 | 8 | 13" | 400 | 400 | 5000 |

3. Others: NA