

**Surface Mount Zener Diodes**
**VZ : 3.3 to 330V P<sub>D</sub>=1W**

# SMA4728A thru SZ1330A

**Features**

- Glass passivated chip
- Low leakage
- Built in strain relief
- Low inductance
- High peak reverse power dissipation
- Lead ( Pb ) free components
- For use in stabilizing and clipping with high power rating

**Mechanical Data**

- Case : JEDEC DO-214AC(SMA) molded plastic body
- Epoxy: UL 94V-0 rate flame retardant
- Lead: Solderable per MIL-STD-750, method 2026
- Polarity : Color band denotes cathode end
- Mounting position : Any

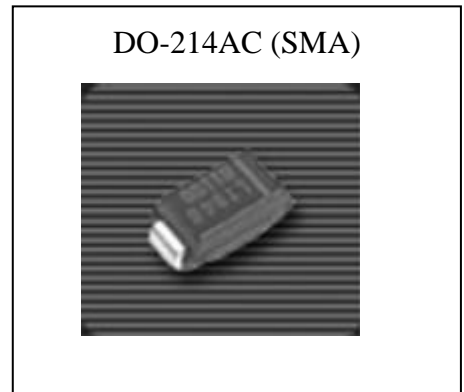
**Outline**

**Maximum Ratings** (T<sub>A</sub>=25°C, unless otherwise noted)

Parameter	Symbol	Value	Unit
DC power dissipation at T <sub>L</sub> =50°C (Note 1)	P <sub>D</sub>	1	W
Maximum forward voltage at I <sub>F</sub> =200mA	V <sub>F</sub>	1.2	V
Maximum thermal resistance, junction-to-ambient (Note 2)	R <sub>θJA</sub>	170	°C/W
Operating junction and storage temperature range	T <sub>J</sub> ;T <sub>STG</sub>	-55 ~ +175	°C

 Notes: 1. T<sub>L</sub>=lead temperature at 3/8" (9.5mm) from body

2. Valid provided that leads are kept at ambient temperature at a distance of 10mm from case

**Ordering Information**

Device	Package	Shipping
SMAXXXXA-0-T4-G	SMA	7500 pcs / Tape & Reel
SZXXXXA-0-T4-G	(Pb-free lead plating and halogen-free package)	

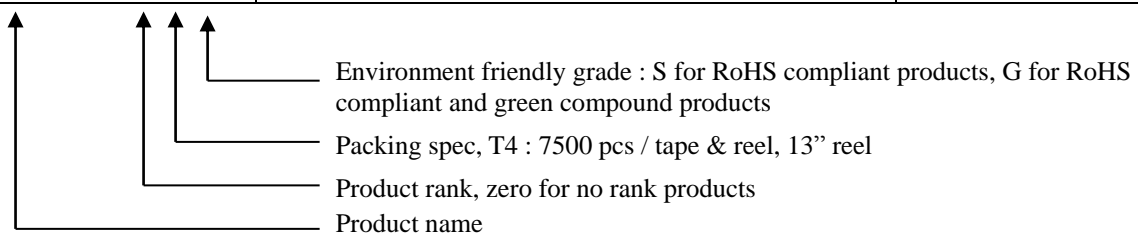



**Electrical Characteristics** Ratings at 25°C ambient temperature, unless otherwise noted.

Part Number	Device marking code	Nominal zener voltage		Maximum zener impedance			Maximum reverse leakage Current		Maximum DC zener current	Maximum surge current
		V <sub>Z</sub> @I <sub>ZT</sub>	I <sub>ZT</sub>	Z <sub>ZT</sub> @I <sub>ZT</sub>	Z <sub>ZK</sub> @I <sub>ZK</sub>	I <sub>ZK</sub>	I <sub>R</sub> @V <sub>R</sub>		I <sub>ZM</sub>	I <sub>RM</sub>
		(V)	(mA)	(Ω)	(Ω)	(mA)	(μA)	(V)	(mA)	(mA)
SMA4728A	28A	3.3	76.0	10.0	400	1.00	100.0	1.0	274.0	1370
SMA4729A	29A	3.6	69.0	10.0	400	1.00	100.0	1.0	251.0	1255
SMA4730A	30A	3.9	64.0	9.0	400	1.00	50.0	1.0	232.0	1160
SMA4731A	31A	4.3	58.0	9.0	400	1.00	10.0	1.0	210.0	1050
SMA4732A	32A	4.7	53.0	8.0	500	1.00	10.0	1.0	192.0	960
SMA4733A	33A	5.1	49.0	7.0	550	1.00	10.0	1.0	177.0	885
SMA4734A	34A	5.6	45.0	5.0	600	1.00	10.0	2.0	161.0	805
SMA4735A	35A	6.2	41.0	2.0	700	1.00	10.0	3.0	146.0	730
SMA4736A	36A	6.8	37.0	3.5	700	1.00	5.0	4.0	133.0	660
SMA4737A	37A	7.5	34.0	4.0	700	0.50	5.0	5.0	121.0	605
SMA4738A	38A	8.2	31.0	4.5	700	0.50	5.0	6.0	110.0	550
SMA4739A	39A	9.1	28.0	5.0	700	0.50	0.5	7.0	100.0	500
SMA4740A	40A	10.0	25.0	7.0	700	0.25	0.5	7.6	91.0	454
SMA4741A	41A	11.0	23.0	8.0	700	0.25	0.1	8.4	83.0	414
SMA4742A	42A	12.0	21.0	9.0	700	0.25	0.1	9.1	76.0	380
SMA4743A	43A	13.0	19.0	10.0	700	0.25	0.1	9.9	69.0	344
SMA4744A	44A	15.0	17.0	14.0	700	0.25	0.1	11.4	61.0	305
SMA4745A	45A	16.0	15.5	16.0	700	0.25	0.1	12.2	57.0	285
SMA4746A	46A	18.0	14.0	20.2	750	0.25	0.1	13.7	50.0	250
SMA4747A	47A	20.0	12.5	22.0	750	0.25	0.1	15.2	45.0	225
SMA4748A	48A	22.0	11.5	23.0	750	0.25	0.1	16.7	41.0	205
SMA4749A	49A	24.0	10.5	25.0	750	0.25	0.1	18.2	38.0	190
SMA4750A	50A	27.0	9.5	35.0	750	0.25	0.1	20.6	34.0	170
SMA4751A	51A	30.0	8.5	40.0	1000	0.25	0.1	22.8	30.0	150
SMA4752A	52A	33.0	7.5	45.0	1000	0.25	0.1	25.1	27.0	135
SMA4753A	53A	36.0	7.0	50.0	1000	0.25	0.1	27.4	25.0	125
SMA4754A	54A	39.0	6.5	60.0	1000	0.25	0.1	29.7	23.0	115
SMA4755A	55A	43.0	6.0	70.0	1500	0.25	0.1	32.7	22.0	110
SMA4756A	56A	47.0	5.5	80.0	1500	0.25	0.1	35.8	19.0	95
SMA4757A	57A	51.0	5.0	95.0	1500	0.25	0.1	38.8	18.0	90
SMA4758A	58A	56.0	4.5	110.0	2000	0.25	0.1	42.6	16.0	80
SMA4759A	59A	62.0	4.0	125.0	2000	0.25	0.1	47.1	14.0	70
SMA4760A	60A	68.0	3.7	150.0	2000	0.25	0.1	51.7	13.0	65
SMA4761A	61A	75.0	3.3	175.0	2000	0.25	0.1	56.0	12.0	60
SMA4762A	62A	82.0	3.0	200.0	3000	0.25	0.1	62.2	11.0	55
SMA4763A	63A	91.0	2.8	250.0	3000	0.25	0.1	69.2	10.0	50
SMA4764A	64A	100.0	2.5	350.0	3000	0.25	0.1	76.0	9.0	45
SZ1110A	11Z	110.0	2.3	450.0	4000	0.25	0.1	83.6	8.6	40
SZ1120A	12Z	120.0	2.0	550.0	4500	0.25	0.1	91.2	7.8	37
SZ1130A	13Z	130.0	1.9	700.0	5000	0.25	0.1	98.8	7.0	34
SZ1150A	15Z	150.0	1.7	1000.0	6000	0.25	0.1	114.0	6.4	30
SZ1160A	16Z	160.0	1.6	1100.0	6500	0.25	0.1	121.6	5.8	28

**Electrical Characteristics(Cont.)**

Part Number	Device marking code	Nominal zener voltage		Maximum zener impedance			Maximum reverse leakage Current		Maximum DC zener current	Maximum surge current
		V <sub>Z</sub> @I <sub>ZT</sub>	I <sub>ZT</sub>	Z <sub>ZT</sub> @I <sub>ZT</sub>	Z <sub>ZK</sub> @I <sub>ZK</sub>	I <sub>ZK</sub>	I <sub>R</sub> @V <sub>R</sub>		I <sub>ZM</sub>	I <sub>RM</sub>
		(V)	(mA)	(Ω)	(Ω)	(mA)	(μA)	(V)	(A)	(A)
SZ1180A	18Z	180.0	1.4	1200.0	7000	0.25	0.1	136.8	5.2	25
SZ1200A	20Z	200.0	1.2	1900.0	9990	0.25	0.1	152.0	4.7	22
SZ1220A	22Z	220.0	1.0	1600.0	8000	0.25	0.1	167.2	4.0	20
SZ1240A	24Z	240.0	0.9	1800.0	8500	0.25	0.1	182.4	3.8	19
SZ1250A	25Z	250.0	0.9	2000.0	9000	0.25	0.1	190.0	3.6	18
SZ1270A	27Z	270.0	0.8	2100.0	9000	0.25	0.1	205.0	3.3	16
SZ1300A	30Z	300.0	0.8	2300.0	9500	0.25	0.1	228.0	3.0	15
SZ1330A	33Z	330.0	0.7	2500.0	9500	0.25	0.1	250.2	2.7	13

Note: 1. The type number listed have a standard tolerance on the nominal zener voltage of ±5%.

2. The reverse surge current is a non-repetitive, 8.3ms pulse width square wave or equivalent sine-wave superimposed on I<sub>ZT</sub> per JEDEC.

**Recommended soldering footprint**

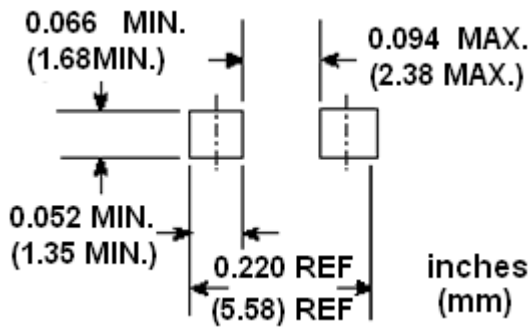

**Typical Characteristics and Characteristics(TA=25°C, unless otherwise noted)**

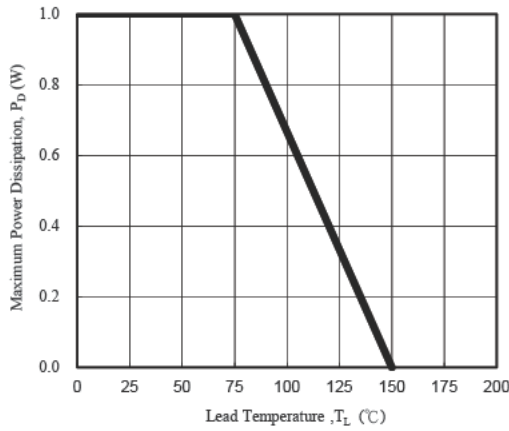

Fig. 1 - Power Temperature Derating Curve

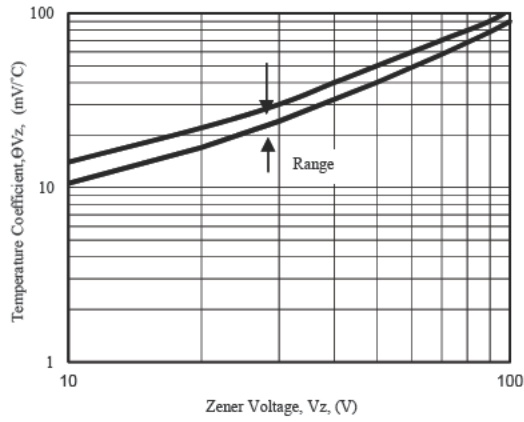

Fig. 2 - Temperature Coefficients v.s. Zener Voltage

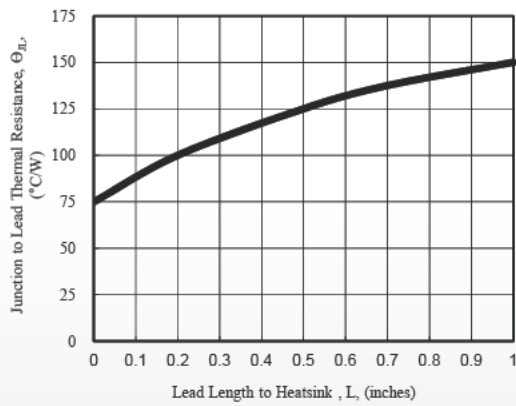

Fig. 3 - Typical Thermal Resistance v.s. Lead Length

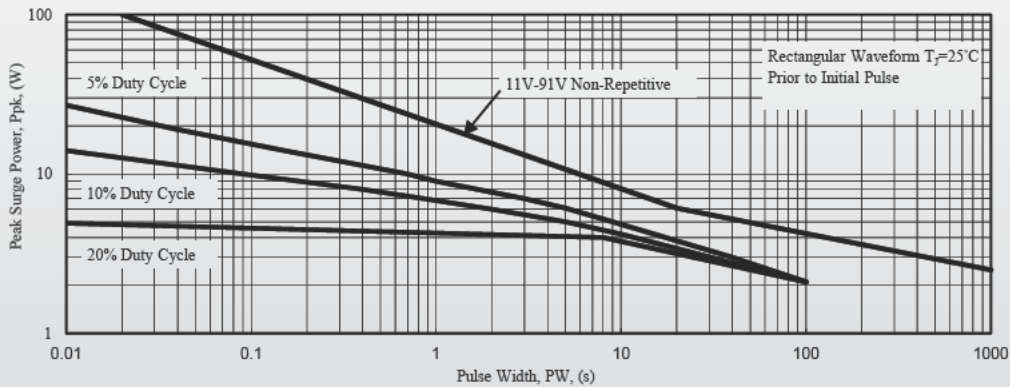
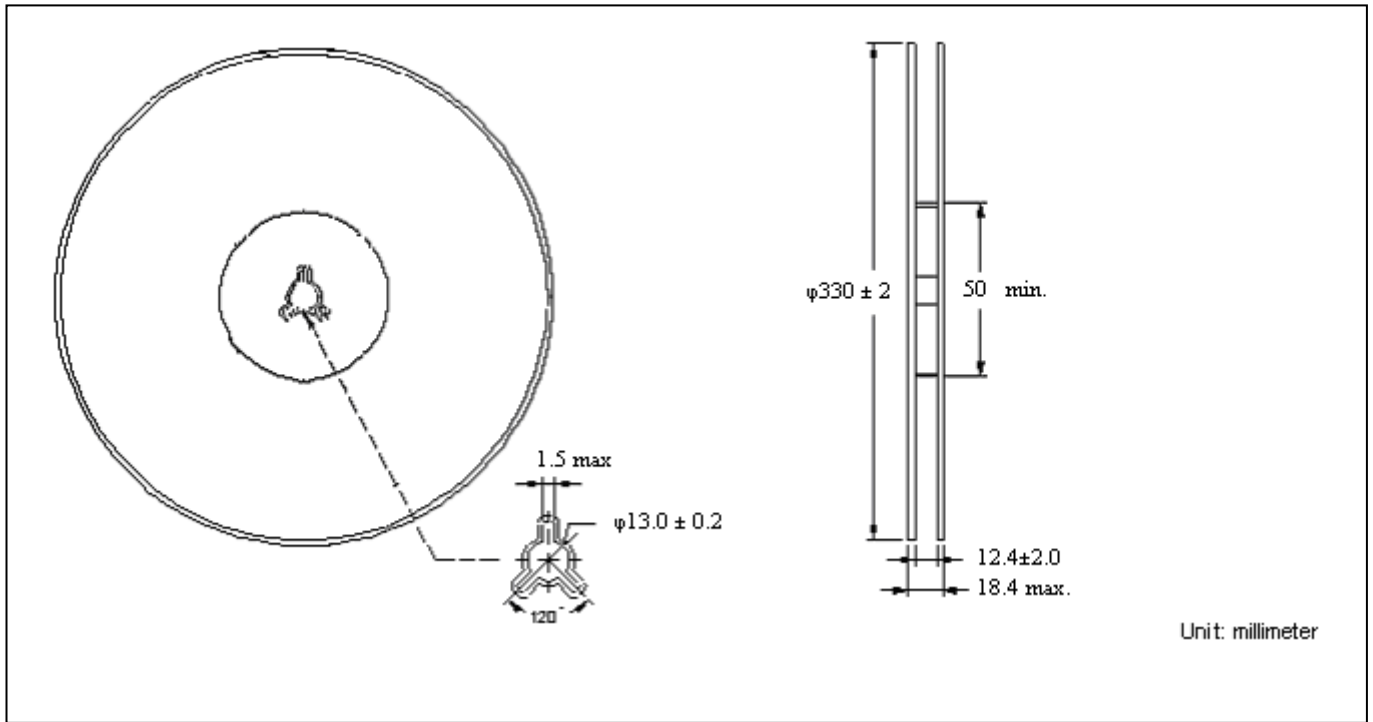
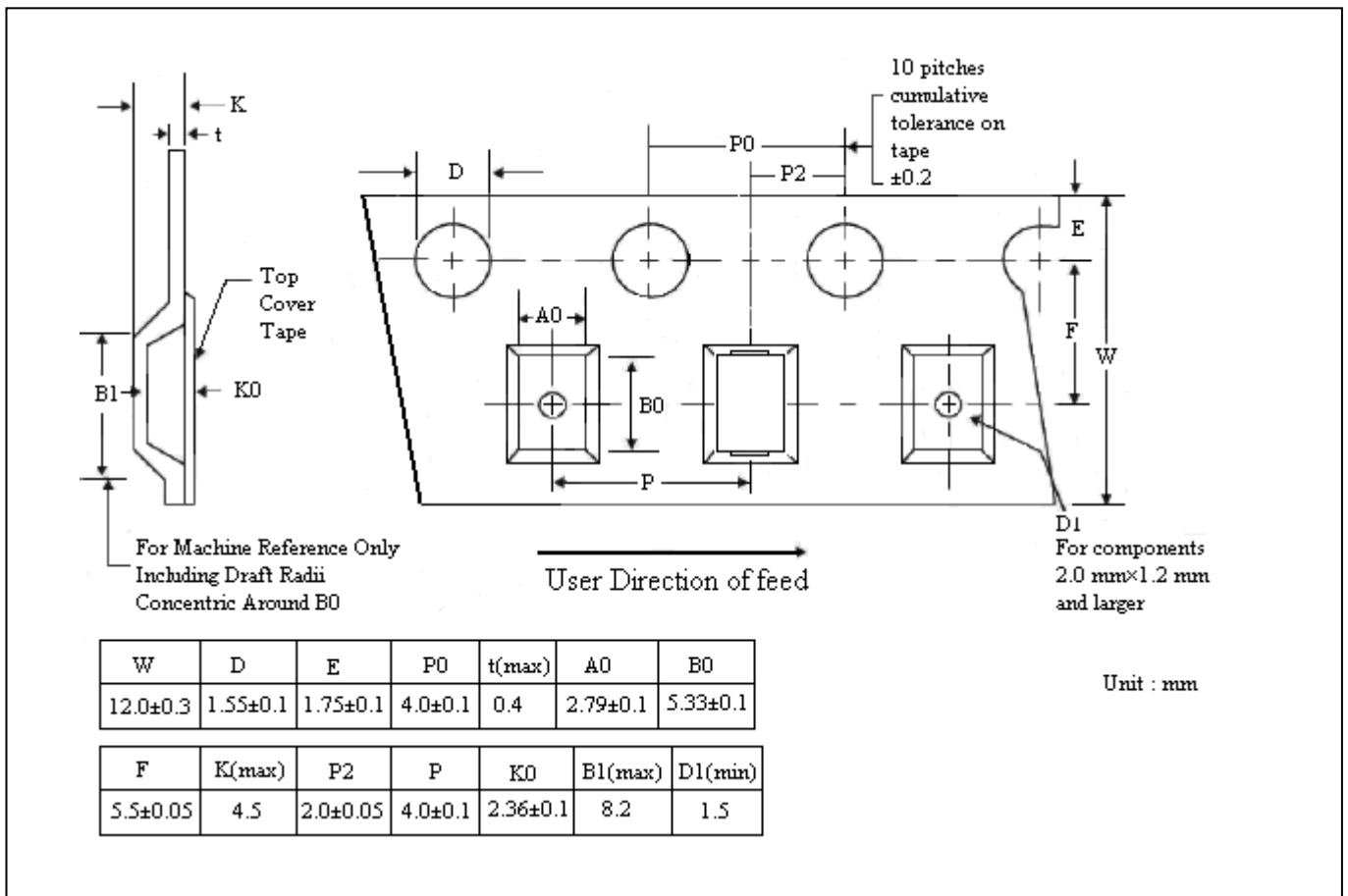

Fig. 4 - Maximum Surge Power

**Reel Dimension**



**Carrier Tape Dimension**



**Recommended wave soldering condition**

Product	Peak Temperature	Soldering Time
Pb-free devices	260 +0/-5 °C	5 +1/-1 seconds

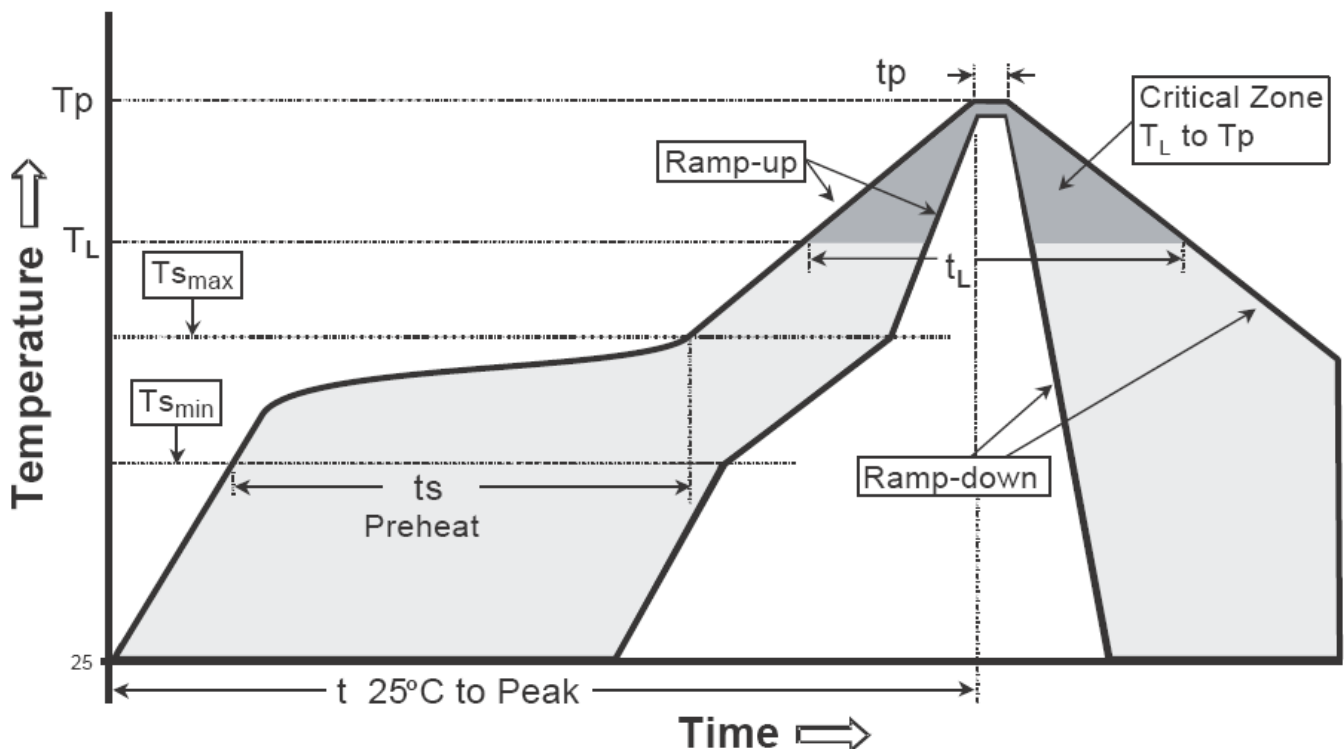
**Recommended temperature profile for IR reflow**

Profile feature	Sn-Pb eutectic Assembly	Pb-free Assembly
Average ramp-up rate (Ts_max to Tp)	3°C/second max.	3°C/second max.
Preheat		
-Temperature Min(Ts_min)	100°C	150°C
-Temperature Max(Ts_max)	150°C	200°C
-Time(ts_min to ts_max)	60-120 seconds	60-180 seconds
Time maintained above:		
-Temperature (T_L)	183°C	217°C
- Time (t_L)	60-150 seconds	60-150 seconds
Peak Temperature(Tp)	240 +0/-5 °C	260 +0/-5 °C
Time within 5°C of actual peak temperature(tp)	10-30 seconds	20-40 seconds
Ramp down rate	6°C/second max.	6°C/second max.
Time 25 °C to peak temperature	6 minutes max.	8 minutes max.

Note : All temperatures refer to topside of the package, measured on the package body surface.

**DO-214AC/SMA Dimension**

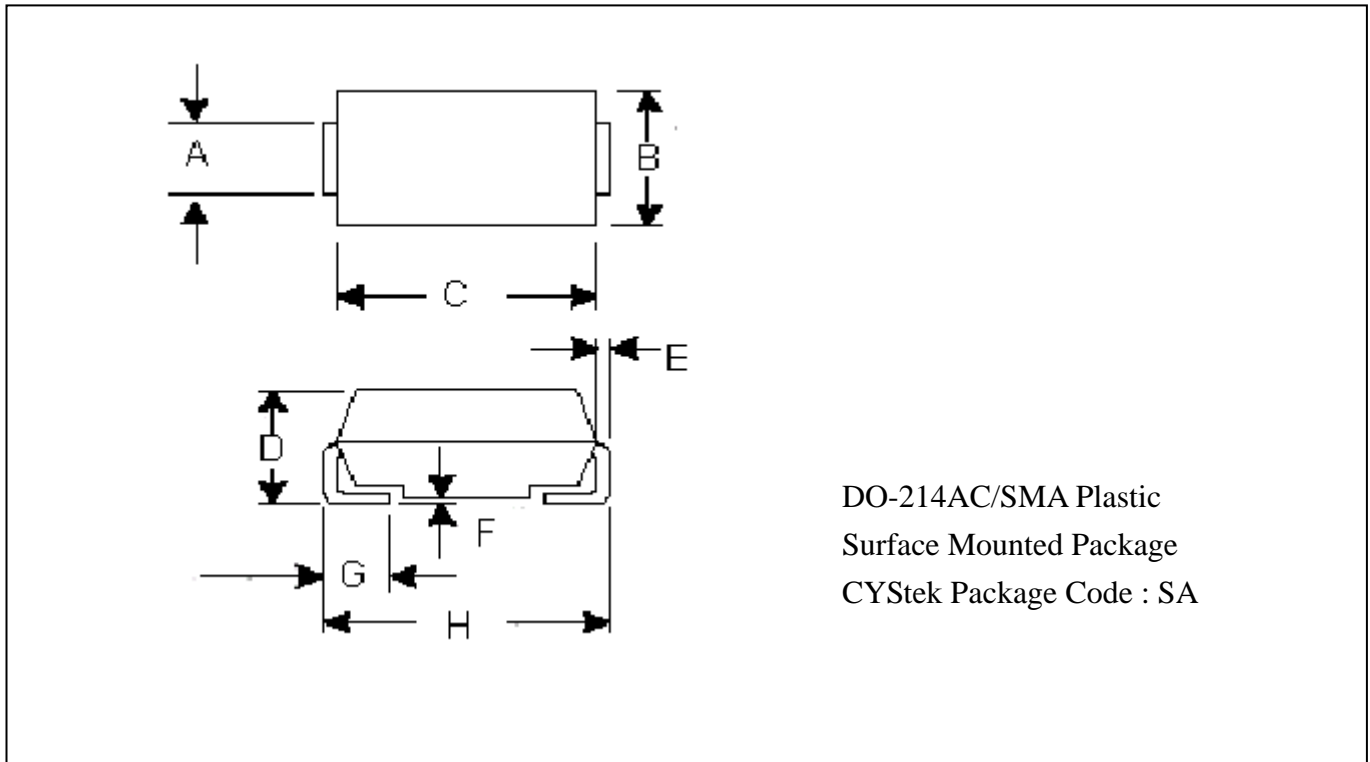

\*:Typical

DIM	Inches		Millimeters		DIM	Inches		Millimeters	
	Min.	Max.	Min.	Max.		Min.	Max.	Min.	Max.
A	0.048	0.064	1.23	1.63	E	0.006	0.012	0.15	0.31
B	0.095	0.109	2.40	2.76	F	0.000	0.008	0.00	0.20
C	0.157	0.181	4.00	4.60	G	0.030	0.059	0.75	1.51
D	0.075	0.089	1.90	2.26	H	0.189	0.206	4.80	5.22

Notes : 1.Controlling dimension : millimeters.  
 2.Maximum lead thickness includes lead finish thickness, and minimum lead thickness is the minimum thickness of base material.  
 3.If there is any question with packing specification or packing method, please contact your local CYStek sales office.

**Material :**

- Lead : Pure tin plated.
- Mold Compound : Epoxy resin family, flammability solid burning class:UL94V-0.

**Important Notice:**

- All rights are reserved. Reproduction in whole or in part is prohibited without the prior written approval of CYStek.
- CYStek reserves the right to make changes to its products without notice.
- CYStek **semiconductor products are not warranted to be suitable for use in Life-Support Applications, or systems.**
- CYStek assumes no liability for any consequence of customer product design, infringement of patents, or application assistance.