

## PROSLIC<sup>®</sup> PROGRAMMABLE WIDEBAND SLIC/CODEC WITH RINGING/BATTERY VOLTAGE GENERATION

### Features

- Dual-mode wideband (50 Hz to 7 kHz)/ narrowband (200 Hz to 3.4 kHz) codec with 16-bit 16 kHz sampling for enhanced audio quality
- Performs all BORSCHT functions
- Ideal for customer premise equipment applications
- Software-programmable internal ringing up to 90 V<sub>PK</sub>
- Integrated battery supply with dynamic voltage output
  - On-chip dc-dc converter continuously minimizes power in all operating modes
  - Entire solution can be powered from a single 3.3 V or 5 V supply
  - 3.3 V to 35 V dc input range
  - Dynamic 0 V to -94.5 V output
  - Low-cost inductor and high-efficiency transformer versions supported
- Software-programmable features and parameters:
  - Ringing frequency, amplitude, cadence, and waveshape
  - 2-wire ac impedance and hybrid
  - Constant current feed (20 to 41 mA)
  - Loop closure and ring trip thresholds
- Software programmable signal generation and audio processing:
  - $\mu$ -law/A-law companding
  - FSK (caller ID) generation
  - Dual audio tone generators
  - Smooth and abrupt polarity reversal
- 100% software-configurable global solution
- Audio loopback, dc, and GR-909 subscriber line diagnostic capabilities
- Lead-free and RoHS-compliant packages available

### Applications

- Voice-over-broadband systems: DSL, cable, wireless
- PBX/IP-PBX/key telephone systems
- Terminal adapters: ISDN, Ethernet, USB

### Description

The Si3216 ProSLIC<sup>®</sup> is a low-voltage CMOS device that provides a complete analog telephone interface supporting both wideband (50 Hz to 7.0 kHz) and narrowband (200 Hz to 3.4 kHz) audio codec modes for enhanced voice quality in Voice-over-IP (VoIP) applications. The ProSLIC integrates subscriber line interface circuit (SLIC), wideband voice codec, and battery generation functionality into a single fully-programmable device for global operation using only one hardware solution. The Si3216's wideband codec provides expanded audio band (50 Hz to 7 kHz), 16 kHz sampling rate, and increased dynamic range for improved audio quality over traditional telephony codecs. The integrated battery supply continuously adapts its output voltage to minimize power and enables the entire solution to be powered from a single 3.3 V (Si3216M only) or 5 V supply. Si3216 features include software-configurable 5 REN internal ringing up to 90 V<sub>PK</sub>, DTMF and caller ID generation, and a comprehensive set of telephony signaling capabilities including expanded support of Japan and China country requirements. The ProSLIC is packaged in a 38-pin QFN and TSSOP, and the Si3201 high-voltage line interface device is packaged in a thermally-enhanced 16-pin SOIC.

### Functional Block Diagram

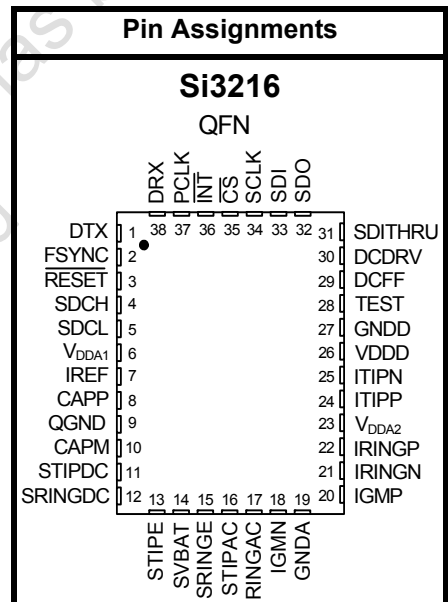
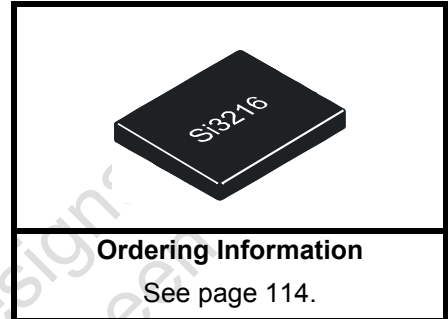
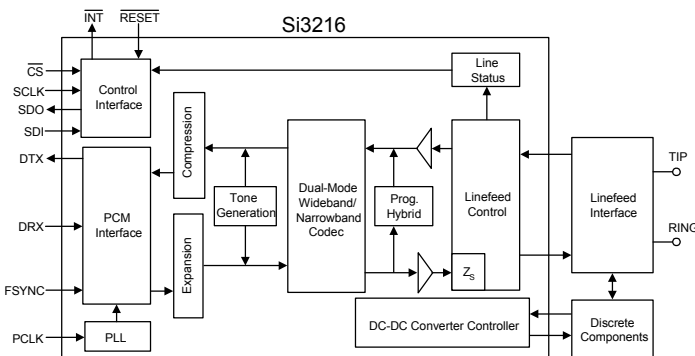

U.S. Patent #6,567,521

U.S. Patent #6,812,744

Other patents pending

Not recommended for new designs.  
Please note the Si3201 has been discontinued.

---

**TABLE OF CONTENTS**

---

<b><u>Section</u></b>	<b><u>Page</u></b>
<b>1. Electrical Specifications</b> .....	<b>4</b>
<b>2. Functional Description</b> .....	<b>27</b>
2.1. Linefeed Interface .....	27
2.2. Battery Voltage Generation and Switching .....	33
2.3. Tone Generation .....	36
2.4. Ringing Generation .....	39
2.5. Audio Path .....	43
2.6. Two-Wire Impedance Matching .....	45
2.7. Clock Generation .....	46
2.8. Interrupt Logic .....	46
2.9. Serial Peripheral Interface .....	46
2.10. PCM Interface .....	49
<b>3. Control Registers</b> .....	<b>52</b>
<b>4. Indirect Registers</b> .....	<b>104</b>
4.1. Oscillators .....	104
4.2. Digital Programmable Gain/Attenuation .....	105
4.3. SLIC Control .....	107
4.4. FSK Control .....	109
<b>5. Pin Descriptions: Si3216</b> .....	<b>110</b>
<b>6. Pin Descriptions: Si3201</b> .....	<b>113</b>
<b>7. Ordering Guides</b> .....	<b>114</b>
<b>8. Package Outline: 38-Pin QFN</b> .....	<b>116</b>
<b>9. Package Outline: 38-Pin TSSOP</b> .....	<b>117</b>
<b>10. Package Outline: 16-Pin ESOIC</b> .....	<b>118</b>
<b>11. Silicon Labs Si3216 Support Documentation</b> .....	<b>119</b>
<b>Document Change List</b> .....	<b>120</b>
<b>Contact Information</b> .....	<b>122</b>

## 1. Electrical Specifications

**Table 1. Absolute Maximum Ratings and Thermal Information<sup>1</sup>**

Parameter	Symbol	Value	Unit
<b>Si3216</b>			
DC Supply Voltage	$V_{DD}, V_{DDA1}, V_{DDA2}$	-0.5 to 6.0	V
Input Current, Digital Input Pins	$I_{IN}$	±10	mA
Digital Input Voltage	$V_{IND}$	-0.3 to ( $V_{DD} + 0.3$ )	V
Operating Temperature Range <sup>2</sup>	$T_A$	-40 to 100	C
Storage Temperature Range	$T_{STG}$	-40 to 150	C
TSSOP-38 Thermal Resistance, Typical	$\theta_{JA}$	70	C/W
QFN-38 Thermal Resistance, Typical	$\theta_{JA}$	35	C/W
Continuous Power Dissipation <sup>2</sup>	$P_D$	0.7	W
<b>Si3201</b>			
DC Supply Voltage	$V_{DD}$	-0.5 to 6.0	V
Battery Supply Voltage	$V_{BAT}$	-104	V
Input Voltage: TIP, RING, SRINGE, STIPE pins	$V_{INH}$	( $V_{BAT} - 0.3$ ) to ( $V_{DD} + 0.3$ )	V
Input Voltage: ITIPP, ITIPN, IRINGP, IRINGN pins	$V_{IN}$	-0.3 to ( $V_{DD} + 0.3$ )	V
Operating Temperature Range <sup>2</sup>	$T_A$	-40 to 100	C
Storage Temperature Range	$T_{STG}$	-40 to 150	C
SOIC-16 Thermal Resistance, Typical <sup>3</sup>	$\theta_{JA}$	55	C/W
Continuous Power Dissipation <sup>2</sup>	$P_D$	0.8 at 70 °C	W
		0.6 at 85 °C	
<b>Notes:</b>			
<ol style="list-style-type: none"> <li>Permanent device damage may occur if the absolute maximum ratings are exceeded. Functional operation should be restricted to the conditions as specified in the operational sections of this data sheet. Exposure to absolute maximum rating conditions for extended periods may affect device reliability.</li> <li>Operation above 125 °C junction temperature may degrade device reliability.</li> <li>Thermal resistance assumes a multi-layer PCB with the exposed pad soldered to a topside PCB pad.</li> </ol>			

Table 2. Recommended Operating Conditions

Parameter	Symbol	Test Condition	Min*	Typ	Max*	Unit
Ambient Temperature	$T_A$	K-grade	0	25	70	°C
Ambient Temperature	$T_A$	B-grade	-40	25	85	°C
Si3216 Supply Voltage	$V_{DDD}, V_{DDA1}, V_{DDA2}$		3.13	3.3/5.0	5.25	V
Si3201 Supply Voltage	$V_{DD}$		3.13	3.3/5.0	5.25	V
Si3201 Battery Voltage	$V_{BAT}$	$V_{BATH} = V_{BAT}$	-96	—	-10	V
<p><b>*Note:</b> All minimum and maximum specifications are guaranteed and apply across the recommended operating conditions. Typical values apply at nominal supply voltages and an operating temperature of 25 °C unless otherwise stated. Product specifications are only guaranteed when the typical application circuit (including component tolerances) is used.</p>						

Not recommended for new designs.  
Please note the Si3201 has been discontinued.

**Table 3. AC Characteristics—Wideband Audio Mode: Si3216**

( $V_{DDA}$ ,  $V_{DDD} = 3.13$  to  $5.25$  V,  $T_A = 0$  to  $70$  °C for K-Grade,  $-40$  to  $85$  °C for B-Grade)

Parameter	Test Condition	Min	Typ	Max	Unit	
<b>TX/RX Performance—Wideband Audio Mode</b>						
Overload Level	THD = 1.5%	2.5	—	—	$V_{PK}$	
Single Frequency Distortion <sup>1</sup>	2-wire – PCM or PCM – 2-wire: 50 Hz–7.0 kHz	—	—	–45	dB	
Signal-to-(Noise + Distortion) Ratio <sup>2</sup>	50 Hz–7.0 kHz D/A or A/D 16-bit Active off-hook and OHT, $Z_{ac} = 600 \Omega$	TBD	—	—		
Audio Tone Generator Signal-to-Distortion Ratio <sup>2</sup>	0 dBm0, Active off-hook and OHT, $Z_{ac} = 600 \Omega$	45	—	—	dB	
Intermodulation Distortion		—	—	–41	dB	
Gain Accuracy <sup>2</sup>	2-wire to PCM, 1014 Hz $Z_{ac} = 600 \Omega$	–0.5	0	0.5	dB	
	PCM to 2-wire, 1014 Hz $Z_{ac} = 600 \Omega$	–0.5	0	0.5	dB	
Gain Accuracy Over Frequency	$Z_{ac} = 600 \Omega$	Figure 1,2	—	—		
Group Delay Over Frequency		—	—	—		
Gain Tracking	1014 Hz sine wave, refer- ence level –10 dBm signal level:	3 dB to –37 dB	–0.25	—	0.25	dB
		–37 dB to –50 dB	–0.5	—	0.5	dB
		–50 dB to –60 dB	–1.0	—	1.0	dB
Round-Trip Group Delay	at 1000 Hz	—	1100	—	$\mu s$	
Gain Step Accuracy	–6 dB to 6 dB	–0.017	—	0.017	dB	
Gain Variation with Temperature	All gain settings	–0.25	—	0.25	dB	
Gain Variation with Supply	$V_{DDA} = V_{DDD} = 3.3/5$ V $\pm 5\%$	–0.1	—	0.1	dB	
2-Wire Return Loss	50 Hz–7.0 kHz $Z_{ac} = 600 \Omega$	20	25	—	dB	
Transhybrid Balance	50 Hz–7.0 kHz $Z_{ac} = 600 \Omega$	20	—	—	dB	
<b>Notes:</b>						
1. The input signal level should be 0 dBm0 for frequencies greater than 100 Hz. For 100 Hz and below, the level should be –10 dBm0. The output signal magnitude at any other frequency will be smaller than the maximum value specified.						
2. Analog signal measured as $V_{TIP} - V_{RING}$ . Assumes ideal line impedance matching.						
3. The level of any unwanted tones within the bandwidth of 0 to 8 kHz does not exceed –55 dBm.						
4. Assumes normal distribution of betas.						

**Table 3. AC Characteristics—Wideband Audio Mode: Si3216 (Continued)** $(V_{DDA}, V_{DDD} = 3.13 \text{ to } 5.25 \text{ V}, T_A = 0 \text{ to } 70 \text{ }^\circ\text{C} \text{ for K-Grade, } -40 \text{ to } 85 \text{ }^\circ\text{C} \text{ for B-Grade})$ 

Parameter	Test Condition	Min	Typ	Max	Unit	
<b>Noise Performance—Wideband Audio Mode</b>						
Idle Channel Noise <sup>3</sup>	7 kHz flat	—	—	23	dBrn	
PSRR from $V_{DDA}$	RX and TX, DC to 7 kHz	40	—	—	dB	
PSRR from $V_{DDD}$	RX and TX, DC to 7 kHz	40	—	—	dB	
PSRR from $V_{BAT}$	RX and TX, DC to 7 kHz	40	—	—	dB	
<b>Longitudinal Performance—Wideband Audio Mode</b>						
Longitudinal to Metallic or PCM Balance	50 Hz–7.0 kHz, $\beta_{Q1,Q2} \geq 150$ , 1% mismatch	—	60	—	dB	
	$\beta_{Q1,Q2} = 60 \text{ to } 240^4$	—	60	—	dB	
	$\beta_{Q1,Q2} = 300 \text{ to } 800^4$	—	60	—	dB	
Metallic to Longitudinal Balance	50 Hz–7.0 kHz	40	—	—	dB	
Longitudinal Impedance	50 Hz–7.0 kHz at TIP or RING Register selectable ETBO/ETBA	00	—	33	—	$\Omega$
		01	—	17	—	$\Omega$
		10	—	17	—	$\Omega$
Longitudinal Current per Pin	Active off-hook 50 Hz–7.0 kHz Register selectable ETBO/ETBA	00	—	4	—	mA
		01	—	8	—	mA
		10	—	8	—	mA
<b>Notes:</b>						
1. The input signal level should be 0 dBm0 for frequencies greater than 100 Hz. For 100 Hz and below, the level should be –10 dBm0. The output signal magnitude at any other frequency will be smaller than the maximum value specified.						
2. Analog signal measured as $V_{TIP} - V_{RING}$ . Assumes ideal line impedance matching.						
3. The level of any unwanted tones within the bandwidth of 0 to 8 kHz does not exceed –55 dBm.						
4. Assumes normal distribution of betas.						

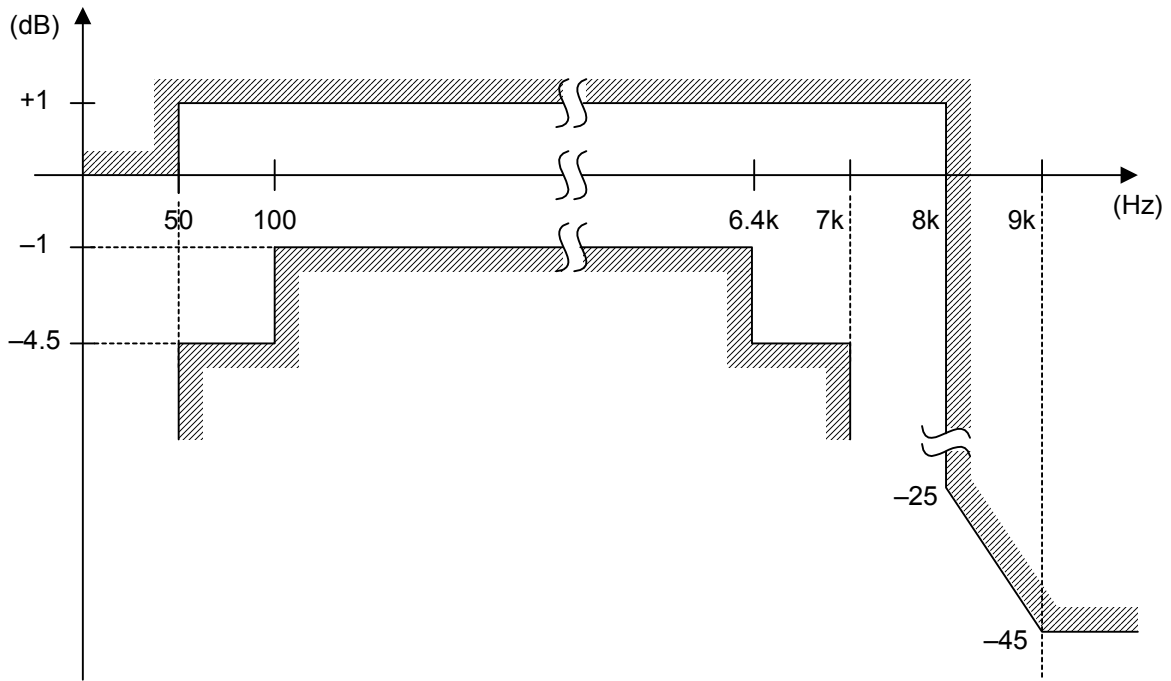

Figure 1. Transmit and Receive Path Attenuation Distortion—Wideband Mode

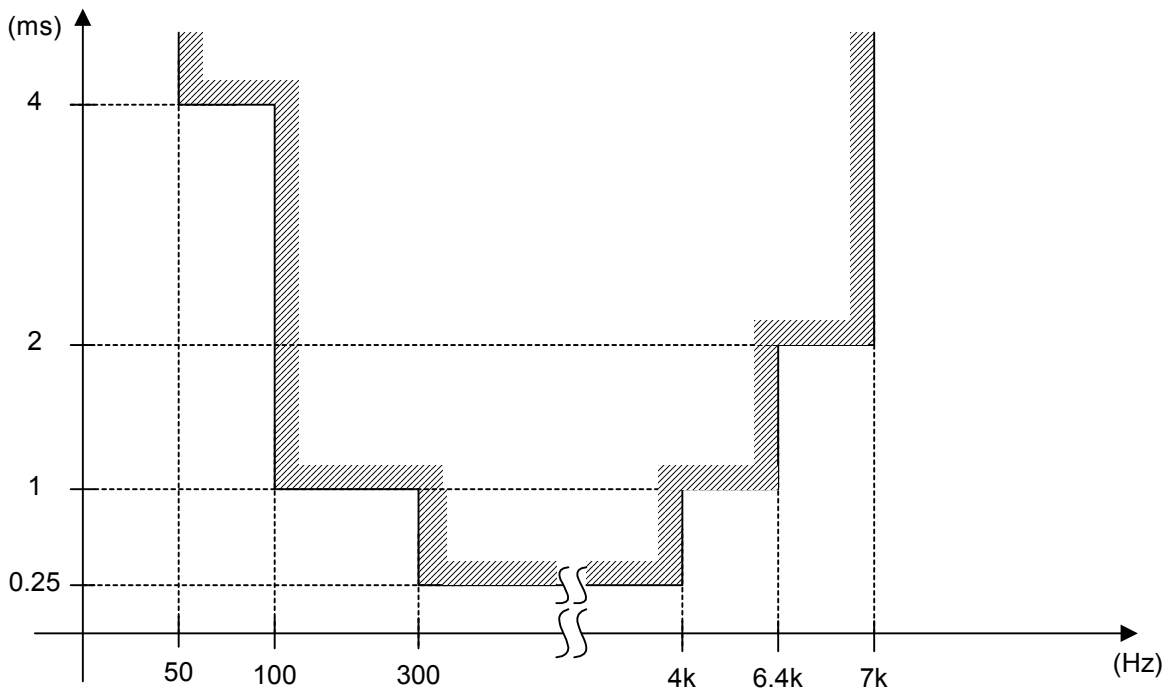

Figure 2. Transmit and Receive Path Group Delay Distortion—Wideband Mode



**Table 4. AC Characteristics—Narrowband Audio Mode**(V<sub>DDA</sub>, V<sub>DDD</sub> = 3.13 to 5.25 V, T<sub>A</sub> = 0 to 70 °C for K-Grade, –40 to 85 °C for B-Grade)

Parameter	Test Condition	Min	Typ	Max	Unit
<b>TX/RX Performance—Narrowband Audio Mode</b>					
Overload Level	THD = 1.5%	2.5	—	—	V <sub>PK</sub>
Single Frequency Distortion <sup>1</sup>	2-wire – PCM or PCM – 2-wire: 200 Hz–3.4 kHz	—	—	–45	dB
Signal-to-(Noise + Distortion) Ratio <sup>2</sup>	200 Hz–3.4 kHz D/A or A/D 16-bit Active off-hook and OHT, any Zac	Figure 3	—	—	
Audio Tone Generator Signal-to-Distortion Ratio <sup>2</sup>	0 dBm0, Active off-hook and OHT, any Zac	45	—	—	dB
Intermodulation Distortion		—	—	–41	dB
Gain Accuracy <sup>2</sup>	2-wire to PCM, 1014 Hz	–0.5	0	0.5	dB
	PCM to 2-wire, 1014 Hz	–0.5	0	0.5	dB
Gain Accuracy Over Frequency		Figure 5,6	—	—	
Group Delay Over Frequency		Figure 7,8	—	—	
Gain Tracking <sup>3</sup>	1014 Hz sine wave, refer- ence level –10 dBm signal level:				
	3 dB to –37 dB	–0.25	—	0.25	dB
	–37 dB to –50 dB	–0.5	—	0.5	dB
	–50 dB to –60 dB	–1.0	—	1.0	dB
Round-Trip Group Delay	at 1000 Hz	—	1100	—	μs
Gain Step Accuracy	–6 dB to 6 dB	–0.017	—	0.017	dB
Gain Variation with Temperature	All gain settings	–0.25	—	0.25	dB
Gain Variation with Supply	V <sub>DDA</sub> = V <sub>DDD</sub> = 3.3/5 V ±5%	–0.1	—	0.1	dB
2-Wire Return Loss	200 Hz–3.4 kHz	30	35	—	dB
Transhybrid Balance	200 Hz–3.4 kHz	30	—	—	dB

**Notes:**

1. The input signal level should be 0 dBm0 for frequencies greater than 100 Hz. For 100 Hz and below, the level should be –10 dBm0. The output signal magnitude at any other frequency will be smaller than the maximum value specified.
2. Analog signal measured as V<sub>TIP</sub> – V<sub>RING</sub>. Assumes ideal line impedance matching.
3. The quantization errors inherent in the μ/A-law companding process can generate slightly worse gain tracking performance in the signal range of 3 dB to –37 dB for signal frequencies that are integer divisors of the 8 kHz PCM sampling rate.
4. The level of any unwanted tones within the bandwidth of 0 to 4 kHz does not exceed –55 dBm.
5. Assumes normal distribution of betas.

**Table 4. AC Characteristics—Narrowband Audio Mode (Continued)**(V<sub>DDA</sub>, V<sub>DDD</sub> = 3.13 to 5.25 V, T<sub>A</sub> = 0 to 70 °C for K-Grade, –40 to 85 °C for B-Grade)

Parameter	Test Condition	Min	Typ	Max	Unit	
<b>Noise Performance—Narrowband Audio Mode</b>						
Idle Channel Noise <sup>4</sup>	C-Message Weighted	—	—	15	dBmC	
	Psophometric Weighted	—	—	–75	dBmP	
	3 kHz flat	—	—	18	dBm	
PSRR from V <sub>DDA</sub>	RX and TX, DC to 3.4 kHz	40	—	—	dB	
PSRR from V <sub>DDD</sub>	RX and TX, DC to 3.4 kHz	40	—	—	dB	
PSRR from V <sub>BAT</sub>	RX and TX, DC to 3.4 kHz	40	—	—	dB	
<b>Longitudinal Performance—Narrowband Audio Mode</b>						
Longitudinal to Metallic or PCM Balance	200 Hz–3.4 kHz, $\beta_{Q1,Q2} \geq 150$ , 1% mismatch	—	60	—	dB	
	$\beta_{Q1,Q2} = 60$ to 240 <sup>5</sup>	—	60	—	dB	
	$\beta_{Q1,Q2} = 300$ to 800 <sup>5</sup>	—	60	—	dB	
	Using Si3201	—	60	—	dB	
Metallic to Longitudinal Balance	200 Hz–3.4 kHz	40	—	—	dB	
Longitudinal Impedance	200 Hz–3.4 kHz at TIP or RING Register selectable ETBO/ETBA	00	—	33	—	$\Omega$
		01	—	17	—	$\Omega$
		10	—	17	—	$\Omega$
Longitudinal Current per Pin	Active off-hook 200 Hz–3.4 kHz Register selectable ETBO/ETBA	00	—	4	—	mA
		01	—	8	—	mA
		10	—	8	—	mA

**Notes:**

1. The input signal level should be 0 dBm0 for frequencies greater than 100 Hz. For 100 Hz and below, the level should be –10 dBm0. The output signal magnitude at any other frequency will be smaller than the maximum value specified.
2. Analog signal measured as V<sub>TIP</sub> – V<sub>RING</sub>. Assumes ideal line impedance matching.
3. The quantization errors inherent in the  $\mu$ /A-law companding process can generate slightly worse gain tracking performance in the signal range of 3 dB to –37 dB for signal frequencies that are integer divisors of the 8 kHz PCM sampling rate.
4. The level of any unwanted tones within the bandwidth of 0 to 4 kHz does not exceed –55 dBm.
5. Assumes normal distribution of betas.

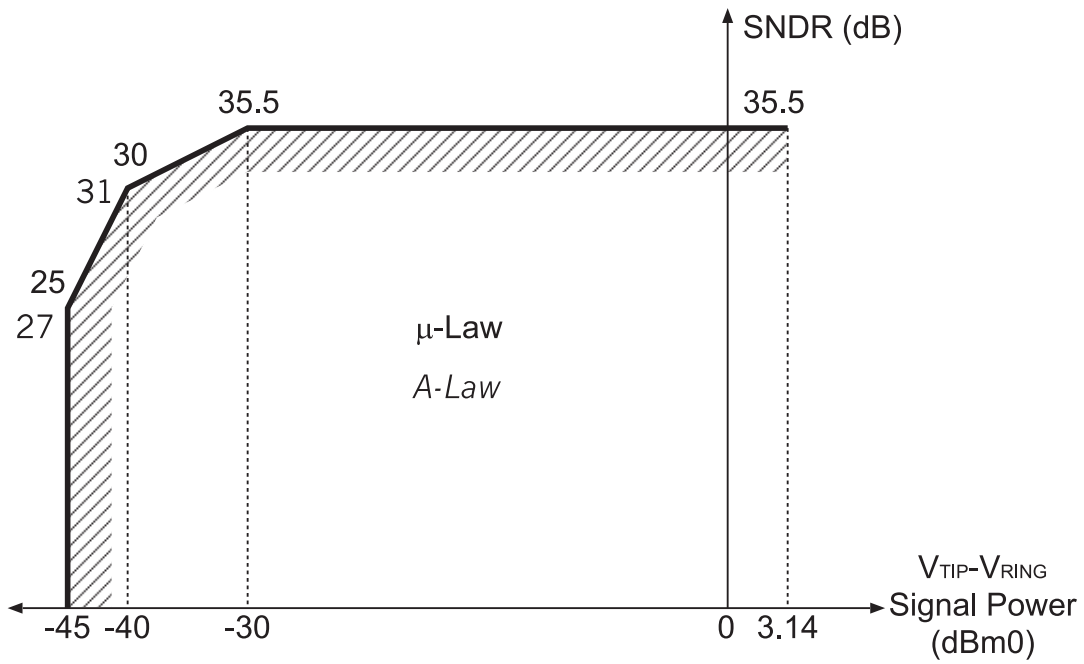

Figure 3. Transmit and Receive Path SNDR—Narrowband Mode

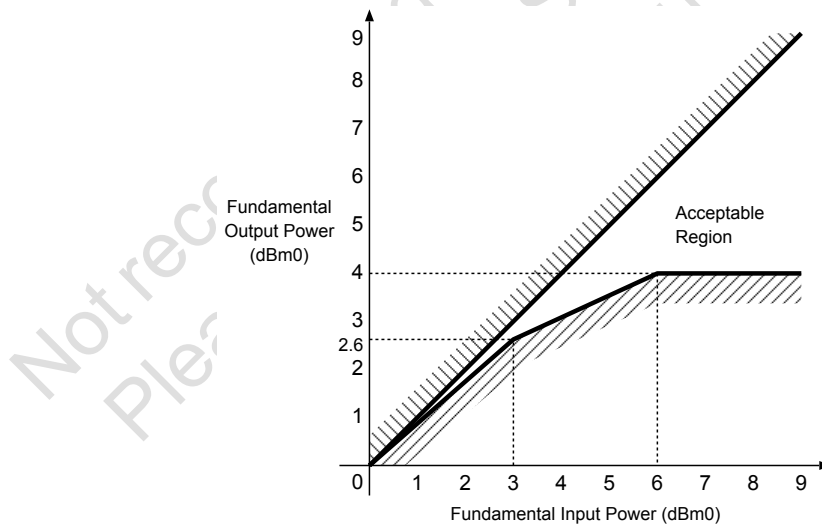

Figure 4. Overload Compression Performance

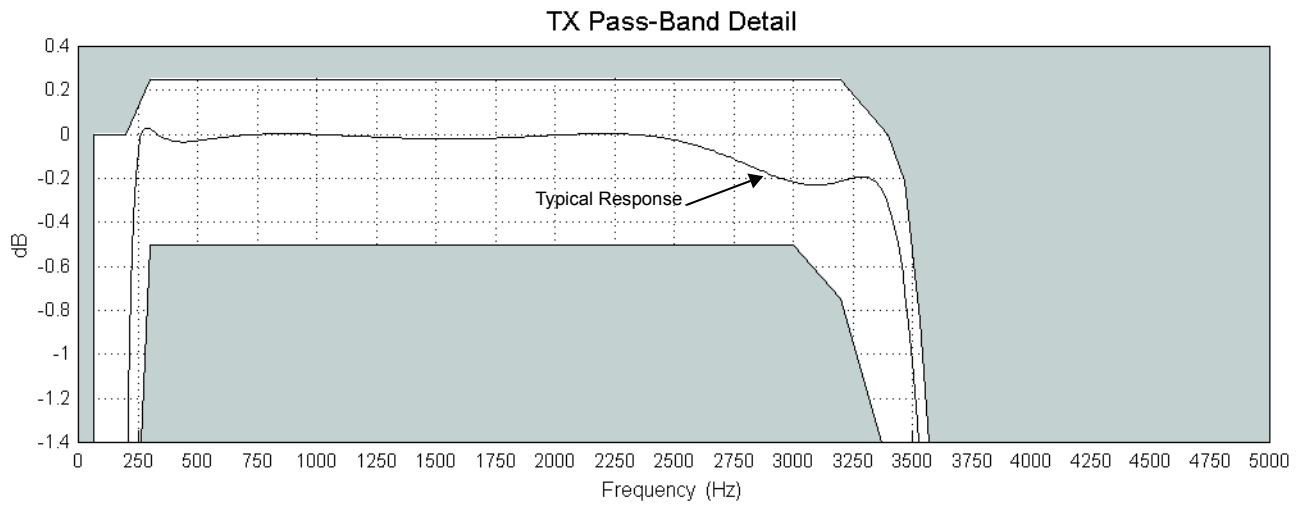
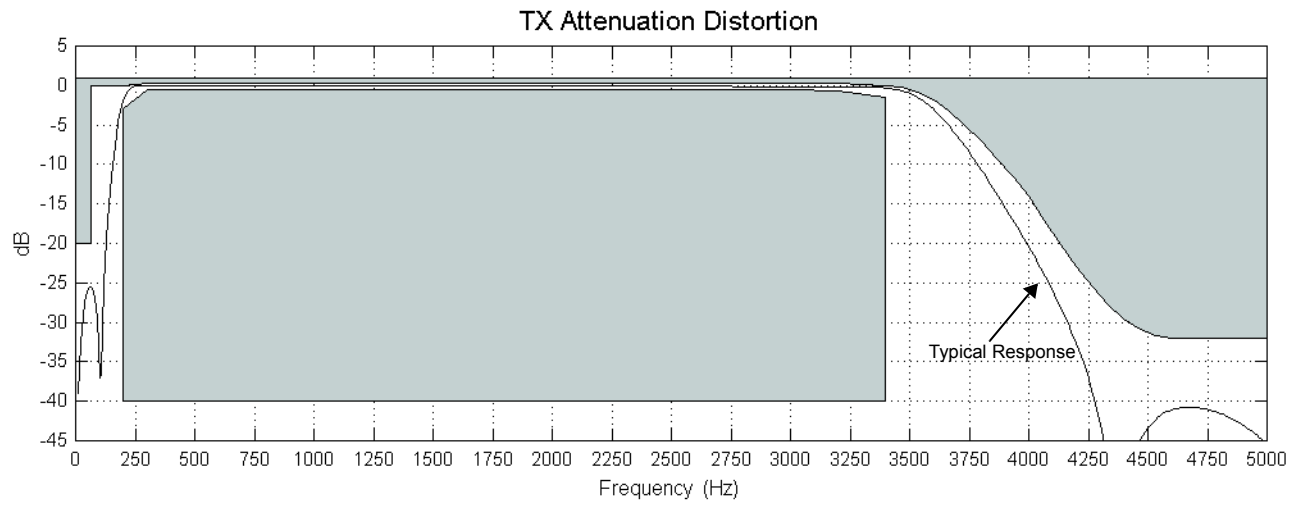

Figure 5. Transmit Path Frequency Response—Narrowband Mode

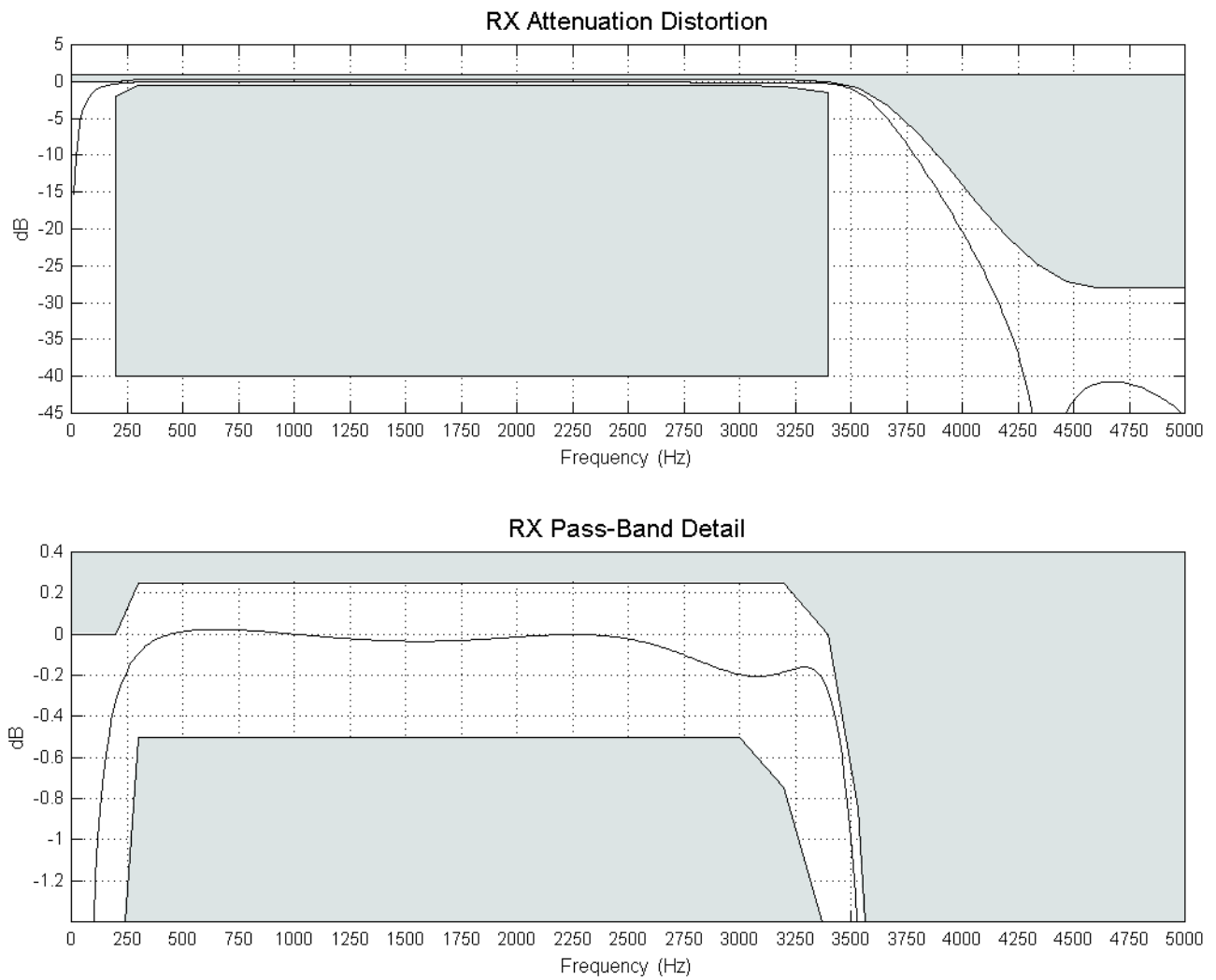

Figure 6. Receive Path Frequency Response—Narrowband Mode

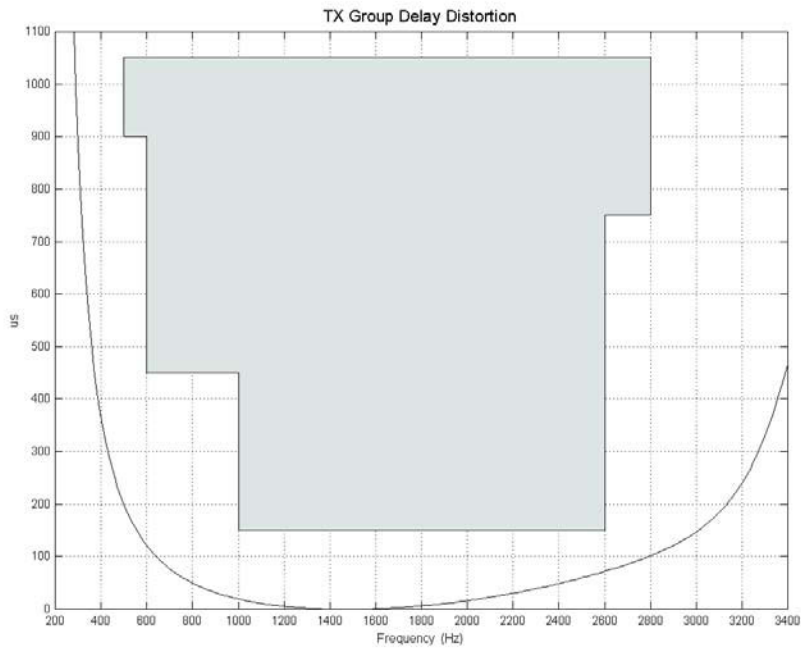

Figure 7. Transmit Group Delay Distortion—Narrowband Mode

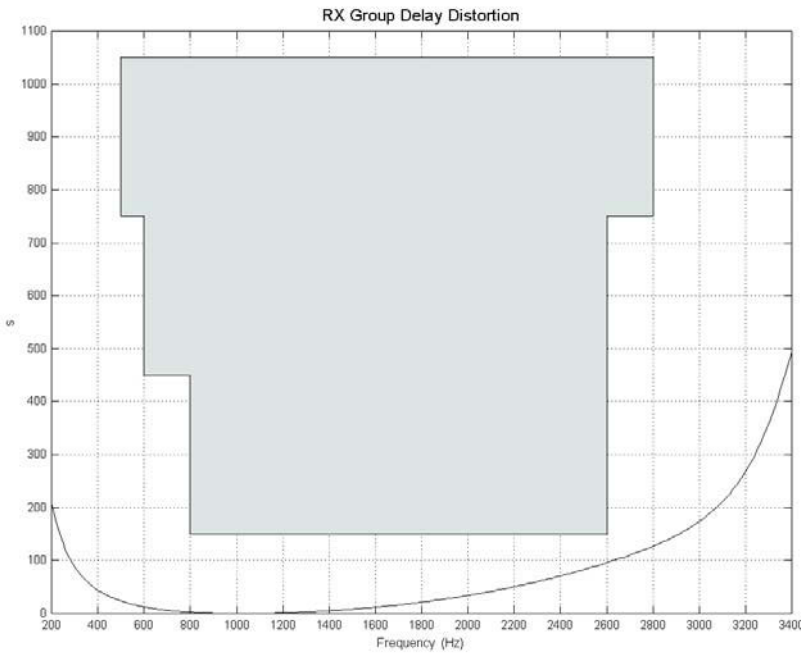

Figure 8. Receive Group Delay Distortion—Narrowband Mode

**Table 5. Linefeed Characteristics**(V<sub>DDA</sub>, V<sub>DDD</sub> = 3.13 to 5.25 V, T<sub>A</sub> = 0 to 70 °C for K-Grade, -40 to 85 °C for B-Grade)

Parameter	Symbol	Test Condition	Min	Typ	Max	Unit
Loop Resistance Range	R <sub>LOOP</sub>	See Note	0	—	160	Ω
DC Loop Current Accuracy		I <sub>LIM</sub> = 29 mA, ETBA = 4 mA	-10	—	10	%
DC Open Circuit Voltage Accuracy		Active Mode; V <sub>OC</sub> = 48 V, V <sub>TIP</sub> - V <sub>RING</sub>	-4	—	4	V
DC Differential Output Resistance	R <sub>DO</sub>	I <sub>LOOP</sub> < I <sub>LIM</sub>	—	160	—	Ω
DC Open Circuit Voltage—Ground Start	V <sub>OCTO</sub>	I <sub>RING</sub> < I <sub>LIM</sub> ; V <sub>RING</sub> wrt ground V <sub>OC</sub> = 48 V	-4	—	4	V
DC Output Resistance—Ground Start	R <sub>ROTO</sub>	I <sub>RING</sub> < I <sub>LIM</sub> ; RING to ground	—	160	—	Ω
DC Output Resistance—Ground Start	R <sub>TOTO</sub>	TIP to ground	150	—	—	kΩ
Loop Closure/Ring Ground Detect Threshold Accuracy		I <sub>THR</sub> = 11.43 mA	-20	—	20	%
Ring Trip Threshold Accuracy		R <sub>THR</sub> = 1100 Ω	-20	—	20	%
Ring Trip Response Time		User Programmable Register 70 and Indirect Register 23	—	—	—	
Ring Amplitude	V <sub>TR</sub>	5 REN load; sine wave; R <sub>LOOP</sub> = 160 Ω, V <sub>BAT</sub> = -75 V	44	—	—	V <sub>rms</sub>
Ring DC Offset	R <sub>OS</sub>	Programmable in Indirect Register 6	0	—	—	V
Trapezoidal Ring Crest Factor Accuracy		Crest factor = 1.3	-.05	—	.05	
Sinusoidal Ring Crest Factor	R <sub>CF</sub>		1.35	—	1.45	
Ringing Frequency Accuracy		f = 20 Hz	-1	—	1	%
Ringing Cadence Accuracy		Accuracy of ON/OFF Times	-50	—	50	ms
Calibration Time		↑CAL to ↓CAL Bit	—	—	600	ms
Power Alarm Threshold Accuracy		At Power Threshold = 300 mW	-25	—	25	%

**Note:** DC resistance round trip; 160 Ω corresponds to 2 kft 26 gauge AWG.

**Table 6. Monitor ADC Characteristics**

( $V_{DDA}, V_{DDD} = 3.13$  to  $5.25$  V,  $T_A = 0$  to  $70$  °C for K-Grade,  $-40$  to  $85$  °C for B-Grade)

Parameter	Symbol	Test Condition	Min	Typ	Max	Unit
Differential Nonlinearity (6-bit resolution)	DNLE		-1/2	—	1/2	LSB
Integral Nonlinearity (6-bit resolution)	INLE		-1	—	1	LSB
Gain Error (voltage)			—	—	10	%
Gain Error (current)			—	—	20	%

**Table 7. Si321x DC Characteristics,  $V_{DDA} = V_{DDD} = 5.0$  V**

( $V_{DDA}, V_{DDD} = 4.75$  to  $5.25$  V,  $T_A = 0$  to  $70$  °C for K-Grade,  $-40$  to  $85$  °C for B-Grade)

Parameter	Symbol	Test Condition	Min	Typ	Max	Unit
High Level Input Voltage	$V_{IH}$		$0.7 \times V_{DDD}$	—	—	V
Low Level Input Voltage	$V_{IL}$		—	—	$0.3 \times V_{DDD}$	V
High Level Output Voltage	$V_{OH}$	DIO1,DIO2,SDITHRU: $I_O = -4$ mA SDO, DTX: $I_O = -8$ mA	$V_{DDD} - 0.6$	—	—	V
		DOUT: $I_O = -40$ mA	$V_{DDD} - 0.8$	—	—	V
Low Level Output Voltage	$V_{OL}$	DIO1,DIO2,DOUT,SDITHRU: $I_O = 4$ mA SDO,INT,DTX: $I_O = 8$ mA	—	—	0.4	V
Input Leakage Current	$I_L$		-10	—	10	$\mu$ A

**Table 8. Si321x DC Characteristics,  $V_{DDA} = V_{DDD} = 3.3$  V**

( $V_{DDA}, V_{DDD} = 3.13$  to  $3.47$  V,  $T_A = 0$  to  $70$  °C for K-Grade,  $-40$  to  $85$  °C for B-Grade)

Parameter	Symbol	Test Condition	Min	Typ	Max	Unit
High Level Input Voltage	$V_{IH}$		$0.7 \times V_{DDD}$	—	—	V
Low Level Input Voltage	$V_{IL}$		—	—	$0.3 \times V_{DDD}$	V
High Level Output Voltage	$V_{OH}$	DIO1,DIO2,SDITHRU: $I_O = -2$ mA SDO, DTX: $I_O = -4$ mA	$V_{DDD} - 0.6$	—	—	V
		DOUT: $I_O = -40$ mA	$V_{DDD} - 0.8$	—	—	V
Low Level Output Voltage	$V_{OL}$	DIO1,DIO2,DOUT,SDITHRU: $I_O = 2$ mA SDO,INT,DTX: $I_O = 4$ mA	—	—	0.4	V
Input Leakage Current	$I_L$		-10	—	10	$\mu$ A



**Table 9. Power Supply Characteristics** $(V_{DDA}, V_{DDD} = 3.13 \text{ to } 5.25 \text{ V}, T_A = 0 \text{ to } 70 \text{ }^\circ\text{C} \text{ for K-Grade, } -40 \text{ to } 85 \text{ }^\circ\text{C} \text{ for B-Grade})$ 

Parameter	Symbol	Test Condition	Typ <sup>1</sup>	Typ <sup>2</sup>	Max	Unit
Power Supply Current, Analog and Digital	$I_A + I_D$	Sleep (RESET = 0)	0.1	0.13	0.3	mA
		Open	33	42.8	49	mA
		Active on-hook ETBO = 4 mA, codec and Gm amplifier powered down	37	53	68	mA
		Active OHT ETBO = 4 mA	57	72	83	mA
		Active off-hook ETBA = 4 mA, $I_{LIM} = 20 \text{ mA}$	73	88	99	mA
		Ground-start	36	47	55	mA
		Ringing Sinewave, REN = 1, $V_{PK} = 56 \text{ V}$	45	55	65	mA
$V_{DD}$ Supply Current (Si3201)	$I_{VDD}$	Sleep mode, RESET = 0	—	100	—	$\mu\text{A}$
		Open (high impedance)	—	100	—	$\mu\text{A}$
		Active on-hook standby	—	110	—	$\mu\text{A}$
		Forward/reverse active off-hook, no $I_{LOOP}$ , ETBO = 4 mA, $V_{BAT} = -24 \text{ V}$	—	1	—	mA
		Forward/reverse OHT, ETBO = 4 mA, $V_{BAT} = -70 \text{ V}$	—	1	—	mA
$V_{BAT}$ Supply Current <sup>3</sup>	$I_{BAT}$	Sleep (RESET = 0)	—	0	—	mA
		Open (DCOF = 1)	—	0	—	mA
		Active on-hook $V_{OC} = 48 \text{ V}$ , ETBO = 4 mA	—	3	—	mA
		Active OHT ETBO = 4 mA	—	11	—	mA
		Active off-hook ETBA = 4 mA, $I_{LIM} = 20 \text{ mA}$	—	30	—	mA
		Ground-start	—	2	—	mA
		Ringing $V_{PK\_RING} = 56 \text{ V}_{PK}$ , sinewave ringing, REN = 1	—	5.5	—	mA
$V_{BAT}$ Supply Slew Rate		When using Si3201	—	—	10	V/ $\mu\text{s}$
<b>Notes:</b>						
1. $V_{DDD}, V_{DDA} = 3.3 \text{ V}$ .						
2. $V_{DDD}, V_{DDA} = 5.25 \text{ V}$ .						
3. $I_{BAT}$ = current from $V_{BAT}$ (the large negative supply). For a switched-mode power supply regulator efficiency of 71%, the user can calculate the regulator current consumption as $I_{BAT} \times V_{BAT} / (0.71 \times V_{DC})$ .						

**Table 10. Switching Characteristics—General Inputs**

$V_{DDA} = V_{DDA} = 3.13$  to  $5.25$  V,  $T_A = 0$  to  $70$  °C for K-Grade,  $-40$  to  $85$  °C for B-Grade,  $C_L = 20$  pF)

Parameter	Symbol	Min	Typ	Max	Unit
Rise Time, $\overline{\text{RESET}}$	$t_r$	—	—	20	ns
$\overline{\text{RESET}}$ Pulse Width	$t_{r1}$	100	—	—	ns

**Note:** All timing (except Rise and Fall time) is referenced to the 50% level of the waveform. Input test levels are  $V_{IH} = V_D - 0.4$  V,  $V_{IL} = 0.4$  V. Rise and Fall times are referenced to the 20% and 80% levels of the waveform.

**Table 11. Switching Characteristics—SPI**

$V_{DDA} = V_{DDA} = 3.13$  to  $5.25$  V,  $T_A = 0$  to  $70$  °C for K-Grade,  $-40$  to  $85$  °C for B-Grade,  $C_L = 20$  pF

Parameter	Symbol	Test Conditions	Min	Typ	Max	Unit
Cycle Time SCLK	$t_c$		0.062	—	—	$\mu$ s
Rise Time, SCLK	$t_r$		—	—	25	ns
Fall Time, SCLK	$t_f$		—	—	25	ns
Delay Time, SCLK Fall to SDO Active	$t_{d1}$		—	—	20	ns
Delay Time, SCLK Fall to SDO Transition	$t_{d2}$		—	—	20	ns
Delay Time, $\overline{\text{CS}}$ Rise to SDO Tri-state	$t_{d3}$		—	—	20	ns
Setup Time, $\overline{\text{CS}}$ to SCLK Fall	$t_{su1}$		25	—	—	ns
Hold Time, $\overline{\text{CS}}$ to SCLK Rise	$t_{h1}$		20	—	—	ns
Setup Time, SDI to SCLK Rise	$t_{su2}$		25	—	—	ns
Hold Time, SDI to SCLK Rise	$t_{h2}$		20	—	—	ns
Delay Time between Chip Selects (Continuous SCLK)	$t_{cs}$		440	—	—	ns
Delay Time between Chip Selects (Non-continuous SCLK)	$t_{cs}$		220	—	—	ns
SDI to SDITHRU Propagation Delay	$t_{d4}$		—	4	10	ns

**Note:** All timing is referenced to the 50% level of the waveform. Input test levels are  $V_{IH} = V_{DDD} - 0.4$  V,  $V_{IL} = 0.4$  V

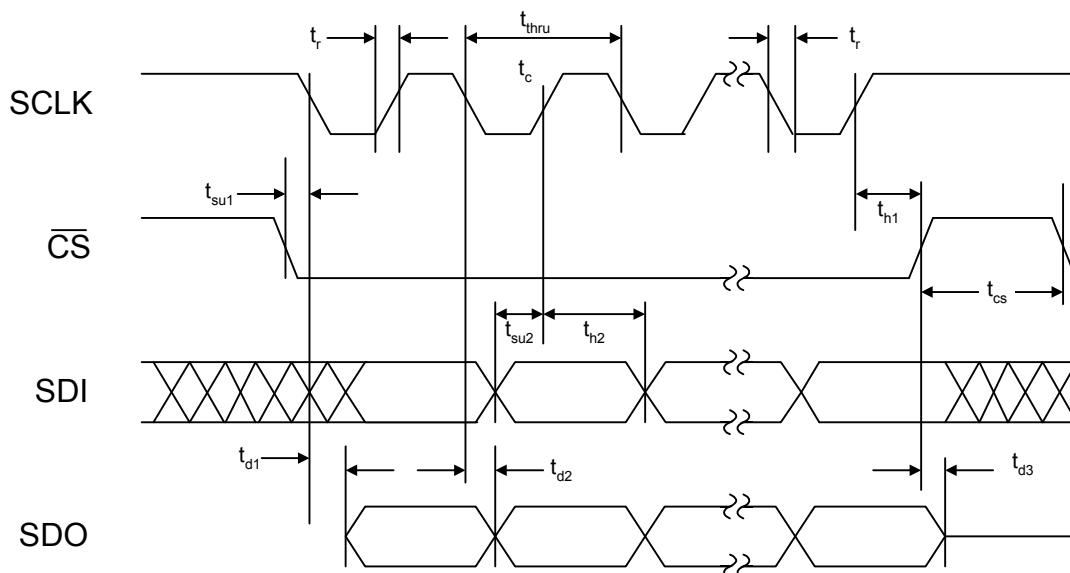

Figure 9. SPI Timing Diagram

Table 12. Switching Characteristics—PCM Highway Serial Interface

$V_D = 3.13$  to  $5.25$  V,  $T_A = 0$  to  $70$  °C for K-Grade,  $-40$  to  $85$  °C for B-Grade,  $C_L = 20$  pF

Parameter	Symbol	Test Conditions	Min <sup>1</sup>	Typ <sup>1</sup>	Max <sup>1</sup>	Units
PCLK Frequency	$1/t_c$		—	0.256	—	MHz
			—	0.512	—	MHz
			—	0.768	—	MHz
			—	1.024	—	MHz
			—	1.536	—	MHz
			—	2.048	—	MHz
			—	4.096	—	MHz
			—	8.192	—	MHz
PCLK Duty Cycle Tolerance	$t_{dty}$		40	50	60	%
PCLK Period Jitter Tolerance	$t_{jitter}$		-120	—	120	ns
Rise Time, PCLK	$t_r$		—	—	25	ns
Fall Time, PCLK	$t_f$		—	—	25	ns
Delay Time, PCLK Rise to DTX Active	$t_{d1}$		—	—	20	ns
Delay Time, PCLK Rise to DTX Transition	$t_{d2}$		—	—	20	ns
Delay Time, PCLK Rise to DTX Tri-state <sup>2</sup>	$t_{d3}$		—	—	20	ns
Setup Time, FSYNC to PCLK Fall	$t_{su1}$		25	—	—	ns
Hold Time, FSYNC to PCLK Fall	$t_{h1}$		20	—	—	ns
Setup Time, DRX to PCLK Fall	$t_{su2}$		25	—	—	ns
Hold Time, DRX to PCLK Fall	$t_{h2}$		20	—	—	ns

**Notes:**

- All timing is referenced to the 50% level of the waveform. Input test levels are  $V_{IH} = V_{IO} - 0.4$  V,  $V_{IL} = 0.4$  V.
- Spec applies to PCLK fall to DTX tri-state when that mode is selected ( $TRI = 0$ ).

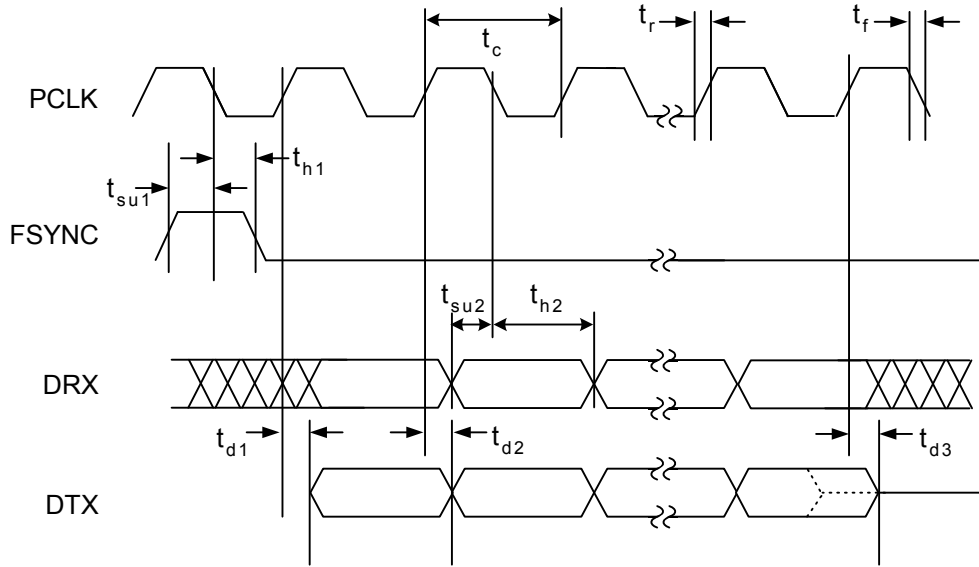

Figure 10. PCM Highway Interface Timing Diagram

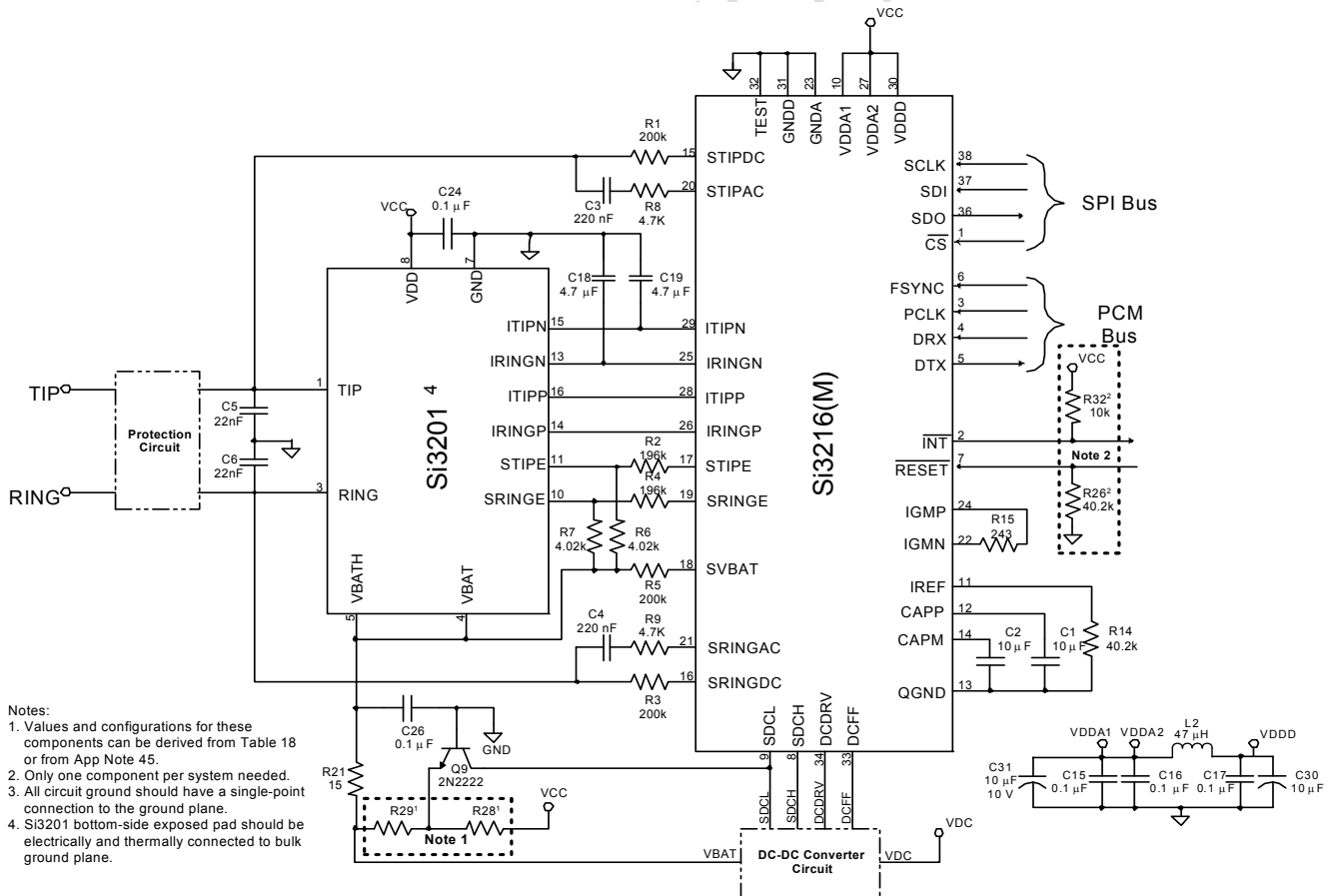
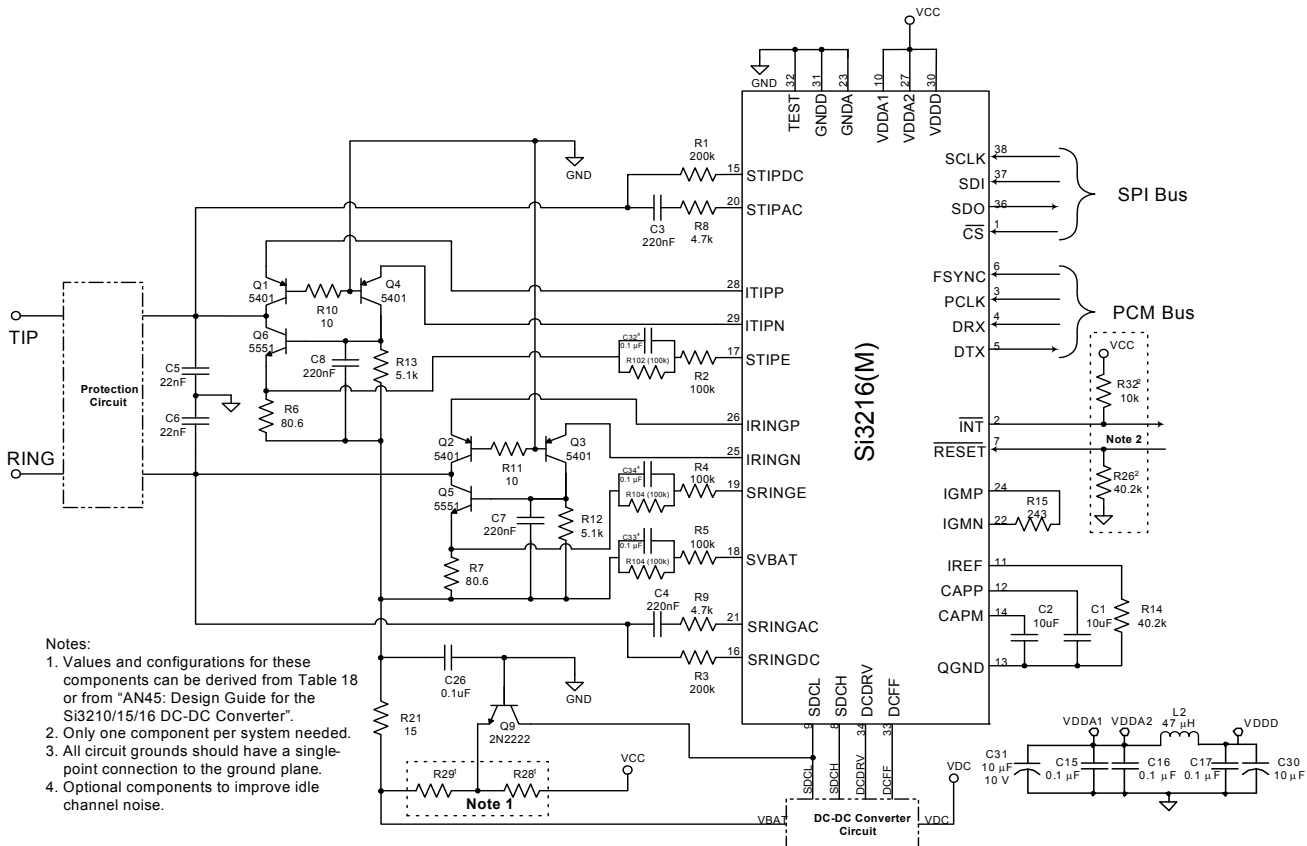

Figure 11. Si3216(M) Application Circuit Using Si3201

Table 13. Si3216(M) + Si3201 External Component Values

Component (s)	Value	Supplier
C1,C2	10 $\mu$ F, 6 V Ceramic or 16 V Low Leakage Electrolytic, $\pm 20\%$	Murata, Nichicon URL1C100MD
C3,C4	220 nF, 100 V, X7R, $\pm 20\%$	Murata, Johanson, Novacap, Venkel
C5,C6	22 nF, 100 V, X7R, $\pm 20\%$	Murata, Johanson, Novacap, Venkel
C15,C16,C17,C24	0.1 $\mu$ F, 6 V, Y5V, $\pm 20\%$	Murata, Johanson, Novacap, Venkel
C18,C19	4.7 $\mu$ F Ceramic, 6 V, X7R, $\pm 20\%$	Murata, Johanson, Novacap, Venkel
C26	0.1 $\mu$ F, 100 V, X7R, $\pm 20\%$	Murata, Johanson, Novacap, Venkel
C30, C31	10 $\mu$ F, 6 V, Electrolytic, $\pm 20\%$	Panasonic
L2	47 $\mu$ H, 150 A	Coilcraft
R1,R3,R5	200 k $\Omega$ , 1/10 W, $\pm 1\%$	
R2,R4	196 k $\Omega$ , 1/10 W, $\pm 1\%$	
R6,R7	4.02 k $\Omega$ , 1/10 W, $\pm 1\%$	
R8,R9	4.7 k $\Omega$ , 1/10 W, $\pm 1\%$	
R14,R26*	40.2 k $\Omega$ , 1/10 W, $\pm 1\%$	
R15	243 $\Omega$ , 1/10 W, $\pm 1\%$	
R21	15 $\Omega$ , 1/4 W, $\pm 5\%$	
R28,R29	1/10 W, 1% (See "AN45: Design Guide for The Si3210 DC-DC Converter" or Table 18 for value selection)	
R32*	10 k $\Omega$ , 1/10 W, $\pm 5\%$	
Q9	60 V, General Purpose Switching NPN	ON Semi MMBT2222ALT1; Central Semi CMPT2222A; Zetex FMMT2222

**\*Note:** Only one component is necessary on each signal in the system.



- Notes:
1. Values and configurations for these components can be derived from Table 18 or from "AN45: Design Guide for the Si3210/15/16 DC-DC Converter".
  2. Only one component per system needed.
  3. All circuit grounds should have a single-point connection to the ground plane.
  4. Optional components to improve idle channel noise.

**Figure 12. Si3216(M) Typical Application Circuit Using Discrete Line Interface Circuit**

**Table 14. Si3216(M) External Component Values**

Component	Value	Supplier/Part Number
C1,C2	10 $\mu$ F, 6 V Ceramic/Tantalum or 16 V Low Leakage Electrolytic, $\pm$ 20%	Murata, Panasonic, Nichicon URL1C100MD
C3,C4	220 nF, 100 V, X7R, $\pm$ 20%	Murata, Johanson, Novacap, Venkel
C5,C6	22 nF, 100 V, X7R, $\pm$ 20%	Murata, Johanson, Novacap, Venkel
C7,C8	220 nF, 50 V, X7R, $\pm$ 20%	Murata, Johanson, Novacap, Venkel
C15,C16,C17	0.1 $\mu$ F, 6 V, Y5V, $\pm$ 20%	Murata, Johanson, Novacap, Venkel
C26	0.1 $\mu$ F, 100 V, X7R, $\pm$ 20%	Murata, Johanson, Novacap, Venkel
C30, C31	10 $\mu$ F, 16 V, Electrolytic, $\pm$ 20%	Panasonic
L2	47 $\mu$ H, 150 A	Coilcraft
Q1,Q2,Q3,Q4	120 V, PNP, BJT	Central Semi CMPT5401; ON Semi MMBT5401LT1, 2N5401; Zetex FM5401; Fairchild 2N5401; Samsung 2N5401
Q5,Q6	120 V, NPN, BJT	Central Semi CZT5551, ON Semi 2N5551; Fairchild 2N5551; Phillips 2N5551
Q9	NPN General Purpose BJT	ON Semi MMBT2222ALT1; Central Semi CMPT2222A; Zetex FM5401

Table 14. Si3216(M) External Component Values (Continued)

R1,R3	200 k $\Omega$ , 1/10 W, $\pm 1\%$	
R2,R4,R5, R102,R104,R105	100 k $\Omega$ , 1/10 W, $\pm 1\%$	
R6,R7	80.6 $\Omega$ , 1/4 W, $\pm 1\%$	
R8,R9	4.7 k $\Omega$ , 1/10 W, $\pm 1\%$	
R10,R11	10 $\Omega$ , 1/10 W, $\pm 5\%$	
R12,R13	5.1 k $\Omega$ , 1/10 W, $\pm 5\%$	
R14,R26*	40.2 k $\Omega$ , 1/10 W, $\pm 1\%$	
R15	243 $\Omega$ , 1/10 W, $\pm 1\%$	
R21	15 $\Omega$ , 1/4 W, $\pm 1\%$	
R28,R29	1/10 W, $\pm 1\%$ (See "AN45: Design Guide for The Si3210 DC-DC Converter" or Table 18 for value selection)	
R32*	10 k $\Omega$ , 1/10 W, $\pm 5\%$	

**\*Note:** Only one component is necessary on each signal in the system.

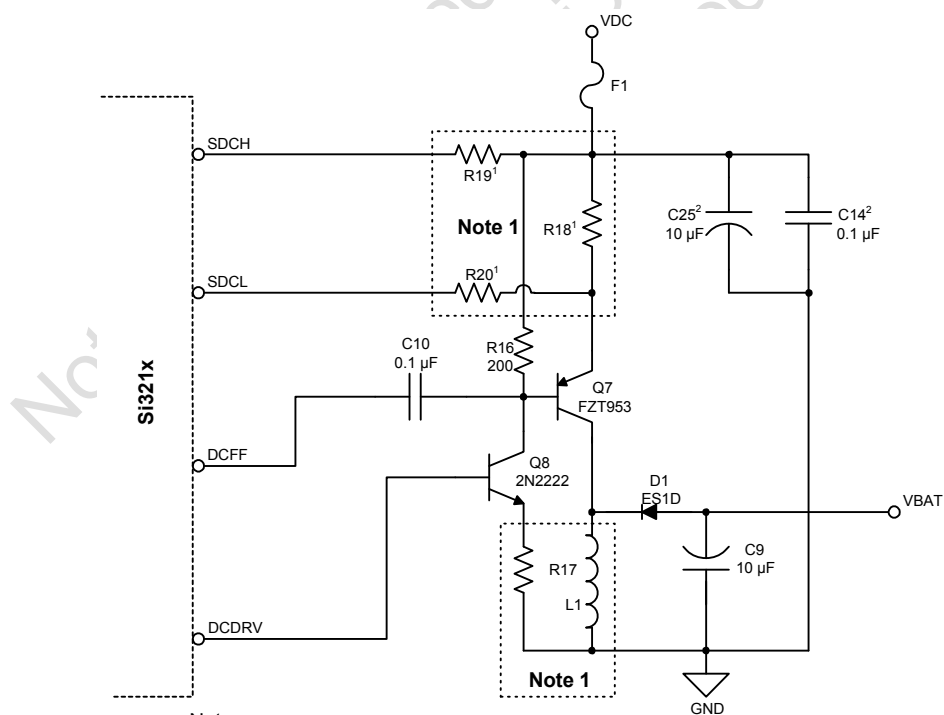

Notes:

1. Values and configurations for these components can be derived from Table 20 or from "AN45: Design Guide for the Si3210/15/16 DC-DC Converter".
2. Voltage rating for C14 and C25 must be greater than VDC.

Figure 13. Si321x BJT/Inductor DC-DC Converter Circuit

**Table 15. Si321x BJT/Inductor DC-DC Converter Component Values**

Component(s)	Value	Supplier
C9	10 $\mu$ F, 100 V, Electrolytic, $\pm$ 20%	Panasonic
C10*	0.1 $\mu$ F, X7R, $\pm$ 20%	Murata, Johanson, Novacap, Venkel
C14*	0.1 $\mu$ F, X7R, $\pm$ 20%	Murata, Johanson, Novacap, Venkel
C25*	10 $\mu$ F, Electrolytic, $\pm$ 20%	Panasonic
R16	200 $\Omega$ , 1/10 W, $\pm$ 5%	
R17	1/10 W, $\pm$ 5% (See "AN45: Design Guide for The Si3210 DC-DC Converter" or Table 20 for value selection)	
R18	1/4 W, $\pm$ 5% (See AN45 or Table 20 for value selection)	
R19,R20	1/10 W, $\pm$ 1% (See AN45 or Table 20 for value selection)	
F1	Fuse	Belfuse SSQ Series
D1	Ultra Fast Recovery 200 V, 1 A Rectifier	General Semi ES1D; Central Semi CMR1U-02
L1	1A, Shielded Inductor (See AN45 or Table 20 for value selection)	API Delevan SPD127 series, Sumida CDRH127 series, Datatronics DR340-1 series, Coilcraft DS5022
Q7	120 V, High Current Switching PNP	Zetex FZT953, FZT955, ZTX953, ZTX955; Sanyo 2SA1552
Q8	60 V, General Purpose Switching NPN	ON Semi MMBT2222ALT1; Central Semi CMPT2222A; Zetex FMMT2222

**\*Note:** Voltage rating of this device must be greater than  $V_{DC}$ .

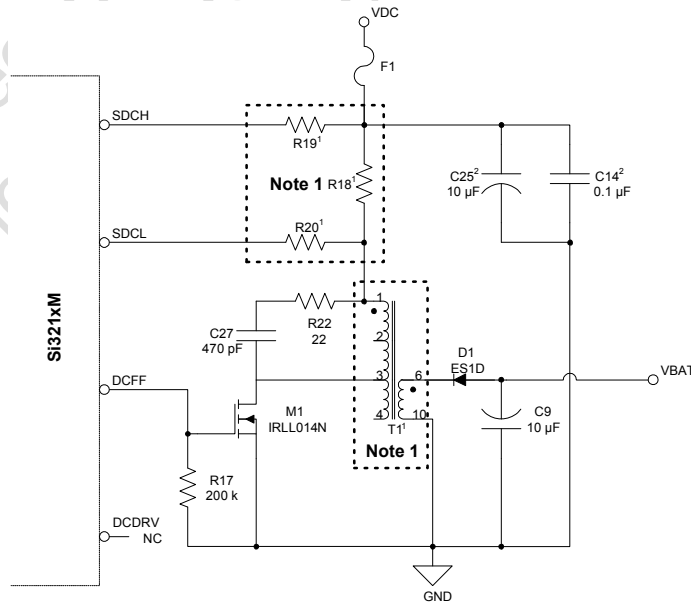

Notes:

1. Values and configurations for these components can be derived from Table 19 or from "AN45: Design Guide for the Si3210/15/16 DC-DC Converter".
2. Voltage rating for C14 and C25 must be greater than VDC.

**Figure 14. Si321xM MOSFET/Transformer DC-DC Converter Circuit**



Table 16. Si321xM MOSFET/Transformer DC-DC Converter Component Values

Component (s)	Value	Supplier
C9	10 $\mu$ F, 100 V, Electrolytic, $\pm 20\%$	Panasonic
C14*	0.1 $\mu$ F, X7R, $\pm 20\%$	Murata, Johanson, Novacap, Venkel
C25*	10 $\mu$ F, Electrolytic, $\pm 20\%$	Panasonic
C27	470 pF, 100 V, X7R, $\pm 20\%$	Murata, Johanson, Novacap, Venkel
R17	200 k $\Omega$ , 1/10 W, $\pm 5\%$	
R18	1/4 W, $\pm 5\%$ (See "AN45: Design Guide for the Si3210 DC-DC Converter" or Table 19 for value selection)	
R19,R20	1/10 W, $\pm 1\%$ (See AN45 or Table 19 for value selection)	
R22	22 $\Omega$ , 1/10 W, $\pm 5\%$	
F1	Fuse	Belfuse SSQ Series
D1	Ultra Fast Recovery 200 V, 1A Rectifier	General Semi ES1D; Central Semi CMR1U-02
T1	Power Transformer	Coiltronic CTX01-15275; Datatronics SM76315; Midcom 31353R-02
M1	100 V, Logic Level Input MOSFET	Intl Rect. IRL014N; Intersil HUF76609D3S; ST Micro STD5NE10L, STN2NE10L

**\*Note:** Voltage rating of this device must be greater than  $V_{DC}$ .

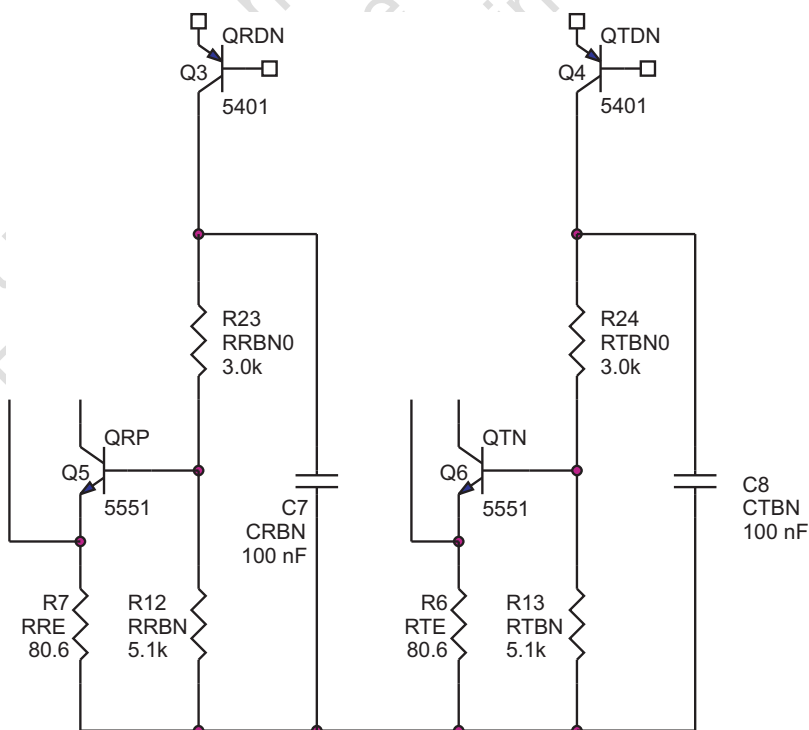

Figure 15. Si321x Optional Equivalent Q5, Q6 Bias Circuit

**Table 17. Si321x Optional Bias Component Values**

Component	Value	Supplier/Part Number
C7,C8	100 nF, 100 V, X7R, $\pm 20\%$	Murata, Johanson, Venkel
R23,R24	3.0 k $\Omega$ , 1/10 W, $\pm 5\%$	

The subcircuit above can be substituted into any of the ProSLIC solutions as an optional bias circuit for Q5, Q6. For this optional subcircuit, C7 and C8 are different in voltage and capacitance to the standard circuit. R23 and R24 are additional components.

**Table 18. Component Value Selection for Si321x/Si321xM**

Component	Value	Comments
R28	1/10 W, 1% resistor For $V_{DD} = 3.3$ V: 26.1 k $\Omega$ For $V_{DD} = 5.0$ V: 37.4 k $\Omega$	$R28 = (V_{DD} + V_{BE})/148 \mu A$ where $V_{BE}$ is the nominal VBE for Q9
R29	1/10 W, 1% resistor For $V_{CLAMP} = 80$ V: 541 k $\Omega$ For $V_{CLAMP} = 85$ V: 574 k $\Omega$ For $V_{CLAMP} = 100$ V: 676 k $\Omega$	$R29 = V_{CLAMP}/148 \mu A$ where $V_{CLAMP}$ is the clamping voltage for $V_{BAT}$

**Table 19. Component Value Selection Examples for Si321xM MOSFET/Transformer DC-DC Converter**

VDC	Ringing Load/Loop Resistance	Transformer Ratio	R18	R19, R20
3.3 V	3 REN/117 $\Omega$	1:2	0.06 $\Omega$	7.15 k $\Omega$
5.0 V	5 REN/117 $\Omega$	1:2	0.10 $\Omega$	16.5 k $\Omega$
12 V	5 REN/117 $\Omega$	1:3	0.68 $\Omega$	56.2 k $\Omega$
24 V	5 REN/117 $\Omega$	1:4	2.20 $\Omega$	121 k $\Omega$

**Note:** There are other system and software conditions that influence component value selection; so, please refer to “AN45: Design Guide for the Si3210 DC-DC Converter” for detailed guidance.

**Table 20. Component Value Selection Examples for Si321x BJT/Inductor DC-DC Converter**

VDC	Ringing Load/Loop Length	L1	R17	R18	R19, R20
5 V	3 REN/117 $\Omega$	33 $\mu H$	100 $\Omega$	0.12 $\Omega$	16.5 k $\Omega$
12 V	5 REN/117 $\Omega$	150 $\mu H$	162 $\Omega$	0.56 $\Omega$	56.2k $\Omega$
24 V	5 REN/117 $\Omega$	560 $\mu H$	274 $\Omega$	2.2 $\Omega$	121 k $\Omega$

**Note:** There are other system and software conditions that influence component value selection, so please refer to “AN45: Design Guide for the Si3210 DC-DC Converter” for detailed guidance.

## 2. Functional Description

The ProSLIC is a single, low-voltage CMOS device that provides all SLIC, codec, DTMF detection, and signal generation functions needed for a complete analog telephone interface. The ProSLIC performs all battery, overvoltage, ringing, supervision, codec, hybrid, and test (BORSCHT) functions. The Si3216 supports wideband (50 Hz–7 kHz) and narrowband (200 Hz–3.4 kHz) audio codec modes to provide an expanded audio band at a 16 kHz sample rate for enhanced audio quality as well as standard telephony audio compatibility. The Si3216 is ideal for Customer Premise Equipment (CPE) where enhanced audio quality is required.

Unlike most monolithic SLICs, the ProSLIC does not require externally-supplied, high-voltage battery supplies. Instead, it generates all necessary battery voltages from a positive dc supply using its own dc-dc converter controller. Two fully-programmable tone generators can produce DTMF tones, phase continuous FSK (caller ID) signaling, and call progress tones. Pulse metering signal generation is also integrated. The Si3201 linefeed interface IC performs all high-voltage functions. As an option, the Si3201 can be replaced with low-cost discrete components.

The linefeed provides programmable on-hook voltage, programmable off-hook loop current, reverse battery operation, loop or ground start operation, and on-hook transmission ringing voltage. Loop current and voltage are continuously monitored using an integrated A/D converter. Balanced 5 REN ringing with or without a programmable dc offset is integrated. The available offset, frequency, waveshape, and cadence options are designed to ring the widest variety of terminal devices and to reduce external controller requirements.

A complete audio transmit and receive path is integrated, including ac impedance and hybrid gain. These features are software-programmable, allowing for a single hardware design to meet global requirements. Digital voice data transfer occurs over a standard PCM bus. Control data is transferred using a standard SPI. The device is available in a 38-pin QFN or TSSOP.

### 2.1. Linefeed Interface

The ProSLIC's linefeed interface offers a rich set of features and programmable flexibility to meet the broadest application requirements. The dc linefeed characteristics are software programmable; key current, voltage, and power measurements are acquired in real time and provided in software registers.

#### 2.1.1. DC Feed Characteristics

The ProSLIC has programmable constant voltage and constant current zones as depicted in Figure 16. Open circuit TIP-to-RING voltage ( $V_{OC}$ ) defines the constant voltage zone and is programmable from 0 V to 94.5 V in 1.5 V steps. The loop current limit ( $I_{LIM}$ ) defines the constant current zone and is programmable from 20 mA to 41 mA in 3 mA steps. The ProSLIC has an inherent dc output resistance ( $R_O$ ) of 160  $\Omega$ .

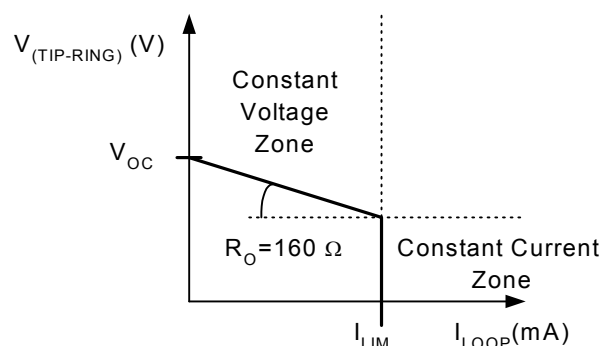

**Figure 16. Simplified DC Current/Voltage Linefeed Characteristic**

The TIP-to-RING voltage ( $V_{OC}$ ) is offset from ground by a programmable voltage ( $V_{CM}$ ) to provide voltage headroom to the positive-most terminal (TIP in forward polarity states and RING in reverse polarity states) for carrying audio signals. Table 21 summarizes the parameters to be initialized before entering an Active state.

**Table 21. Programmable Ranges of DC Linefeed Characteristics**

Parameter	Programmable Range	Default Value	Register Bits	Location*
$I_{LIM}$	20 to 41 mA	20 mA	ILIM[2:0]	Direct Register 71
$V_{OC}$	0 to 94.5 V	48 V	VOC[5:0]	Direct Register 72
$V_{CM}$	0 to 94.5 V	3 V	VCM[5:0]	Direct Register 73

**\*Note:** The ProSLIC uses registers that are both directly and indirectly mapped. A "direct" register is one that is mapped directly.

## 2.1.2. Linefeed Architecture

The ProSLIC is a low-voltage CMOS device that uses either an Si3201 linefeed interface IC or low-cost external components to control the high voltages required for subscriber line interfaces. Figure 17 is a simplified illustration of the linefeed control loop circuit for TIP or RING and the external components used.

The ProSLIC uses both voltage and current sensing to control TIP and RING. DC and ac line voltages on TIP and RING are measured through sense resistors  $R_{DC}$  and  $R_{AC}$ , respectively. The ProSLIC uses linefeed transistors  $Q_P$  and  $Q_N$  to drive TIP and RING.  $Q_{DN}$  isolates the high-voltage base of  $Q_N$  from the ProSLIC.

The ProSLIC measures voltage at various nodes in order to monitor the linefeed current.  $R_{DC}$ ,  $R_{SE}$ , and  $R_{BAT}$  provide access to these measuring points. The sense circuitry is calibrated on-chip to guarantee measurement accuracy with standard external component tolerances. See 2.1.9. "Linefeed Calibration" on page 33 for details.

## 2.1.3. Linefeed Operation States

The ProSLIC linefeed has eight states of operation as shown in Table 22. The state of operation is controlled using the Linefeed Control register (direct Register 64).

The Open state turns off all currents into the external bipolar transistors and can be used in the presence of fault conditions on the line and to generate Open Switch Intervals (OSIs). TIP and RING are tri-stated with a dc output impedance of about 150 k $\Omega$ . The ProSLIC can also automatically enter the Open state if it detects excessive power being consumed in the external bipolar transistors. See 2.1.5. "Power Monitoring and Line Fault Detection" on page 30 for more details.

In the Forward Active and Reverse Active states, linefeed circuitry is on, and the audio signal paths are disabled. In the forward and reverse on-hook transmission states, audio signal paths are enabled to provide data transmission during an on-hook loop condition.

The TIP Open state turns off all control currents to the external bipolar devices connected to TIP and provides an active linefeed on RING for ground start operation.

The RING Open state provides similar operation with the RING drivers off and TIP active.

The Ringing state drives programmable ringing waveforms onto the line.

## 2.1.4. Loop Voltage and Current Monitoring

The ProSLIC continuously monitors the TIP and RING voltages and external BJT currents. These values are available in registers 78–89. Table 23 on page 30 lists the values that are measured and their associated

registers. An internal A/D converter samples the measured voltages and currents from the analog sense circuitry and translates them into the digital domain. The A/D updates the samples at an 800 Hz rate. Two derived values are also reported—loop voltage and loop current. The loop voltage,  $V_{TIP} - V_{RING}$ , is reported as a 1-bit sign, 6-bit magnitude format. For ground start operation, the reported value is the RING voltage. The loop current,  $(I_{Q1} - I_{Q2} + I_{Q5} - I_{Q6})/2$ , is reported in a 1-bit sign, 6-bit magnitude format. In RING open and TIP Open states, the loop current is reported as  $(I_{Q1} - I_{Q2}) + (I_{Q5} - I_{Q6})$ .

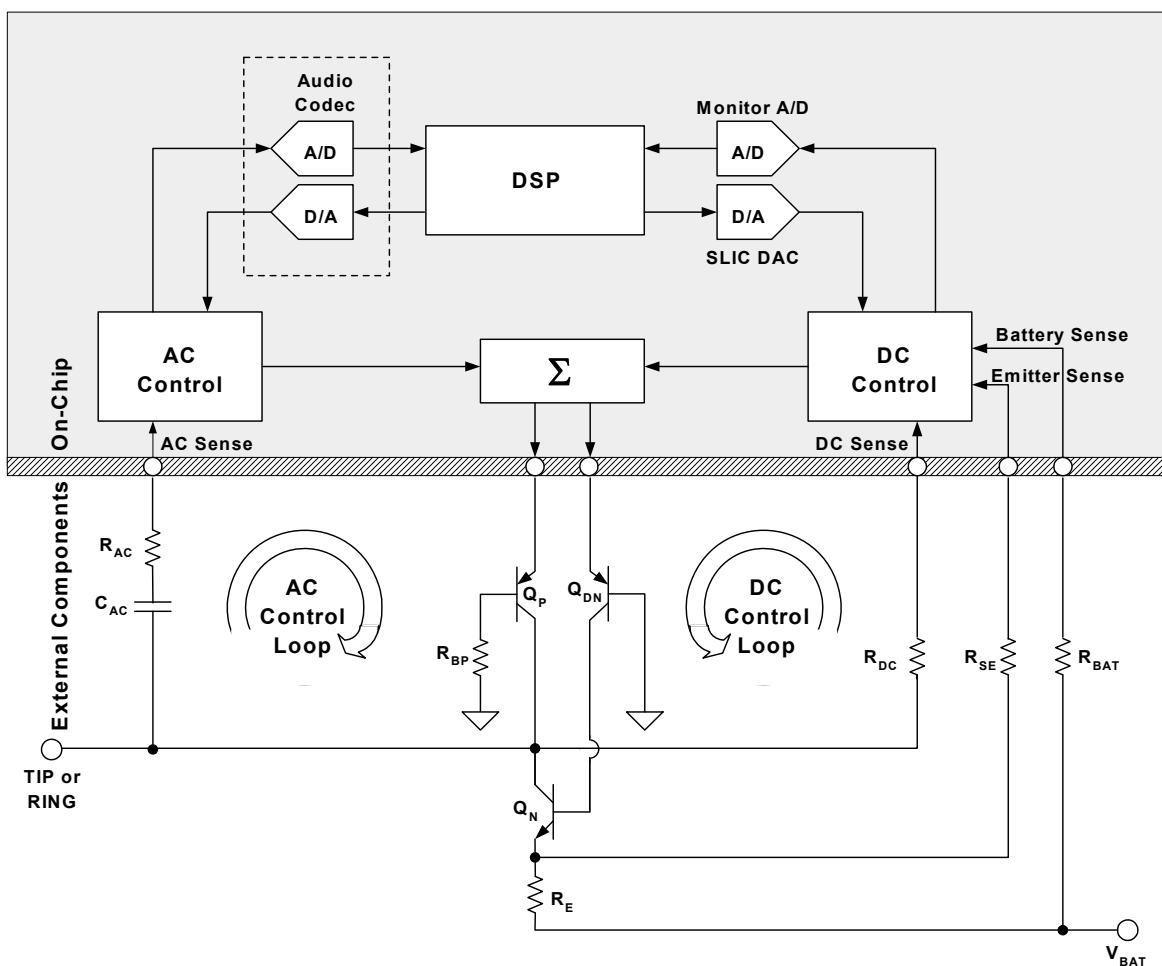

Figure 17. Simplified ProSLIC Linefeed Architecture for TIP and RING Leads (One Shown)

Table 22. ProSLIC Linefeed Operations

LF[2:0]*	Linefeed State	Description
000	Open	TIP and RING tri-stated
001	Forward Active	$V_{TIP} > V_{RING}$
010	Forward On-Hook Transmission	$V_{TIP} > V_{RING}$ ; audio signal paths enabled
011	TIP Open	TIP tri-stated, RING active; used for ground start
100	Ringing	Ringing waveform applied to TIP and RING
101	Reverse Active	$V_{RING} > V_{TIP}$
110	Reverse On-Hook Transmission	$V_{RING} > V_{TIP}$ ; audio signal paths enabled
111	Ring Open	RING tri-stated, TIP active

\*Note: The Linefeed register (LF) is located in direct Register 64.

Table 23. Measured Real Time Linefeed Interface Characteristics

Parameter	Measurement Range	Resolution	Register Bits	Location*
Loop Voltage Sense ( $V_{TIP} - V_{RING}$ )	-94.5 to +94.5 V	1.5 V	LVSP, LVS[6:0]	Direct Register 78
Loop Current Sense	-80 to +80 mA	1.27 mA	LCSP, LCS[5:0]	Direct Register 79
TIP Voltage Sense	0 to -95.88 V	0.376 V	VTIP[7:0]	Direct Register 80
RING Voltage Sense	0 to -95.88 V	0.376 V	VRING[7:0]	Direct Register 81
Battery Voltage Sense 1 ( $V_{BAT}$ )	0 to -95.88 V	0.376 V	VBATS1[7:0]	Direct Register 82
Battery Voltage Sense 2 ( $V_{BAT}$ )	0 to -95.88 V	0.376 V	VBATS2[7:0]	Direct Register 83
Transistor 1 Current Sense	0 to 81.35 mA	0.319 mA	IQ1[7:0]	Direct Register 84
Transistor 2 Current Sense	0 to 81.35 mA	0.319 mA	IQ2[7:0]	Direct Register 85
Transistor 3 Current Sense	0 to 9.59 mA	37.6 $\mu$ A	IQ3[7:0]	Direct Register 86
Transistor 4 Current Sense	0 to 9.59 mA	37.6 $\mu$ A	IQ4[7:0]	Direct Register 87
Transistor 5 Current Sense	0 to 80.58 mA	0.316 mA	IQ5[7:0]	Direct Register 88
Transistor 6 Current Sense	0 to 80.58 mA	0.316 mA	IQ6[7:0]	Direct Register 89

\*Note: The ProSLIC uses registers that are both directly and indirectly mapped. A direct register is one that is mapped directly.

### 2.1.5. Power Monitoring and Line Fault Detection

In addition to reporting voltages and currents, the ProSLIC continuously monitors the power dissipated in each external bipolar transistor. Real time output power of any one of the six linefeed transistors can be read by setting the Power Monitor Pointer (direct Register 76) to point to the desired transistor and then reading the Line Power Output Monitor (direct Register 77).

The real time power measurements are low-pass filtered and compared to a maximum power threshold. Maximum power thresholds and filter time constants are software-programmable and should be set for each transistor pair based on the characteristics of the transistors used. Table 24 describes the registers associated with this function. If the power in any external transistor exceeds the programmed threshold, a power alarm event is triggered. The ProSLIC sets the Power Alarm register bit, generates an interrupt (if enabled), and automatically enters the Open state (if AOPN = 1). This feature protects the external transistors from fault conditions and, combined with the loop voltage and current monitors, allows diagnosis of

the type of fault condition present on the line.

The value of each thermal low-pass filter pole is set according to the following equation:

$$\text{thermal LPF register} = \frac{4096}{800 \times \tau} \times 2^3$$

where  $\tau$  is the thermal time constant of the transistor package; 4096 is the full range of the 12-bit register, and 800 is the sample rate in Hertz. Generally  $\tau = 3$  seconds for SOT223 packages and 0.16 seconds for SOT23, but check with the manufacturer for the thermal time constant of a specific device. For example, the power alarm threshold and low-pass filter values for Q5 and Q6 using an SOT223 package transistor are computed as follows:

$$\text{PPT56} = \frac{P_{\text{MAX}}}{\text{Resolution}} \times 2^7 = \frac{1.28}{0.0304} \times 2^7 = 5389 = 150\text{Dh}$$

Thus, indirect Register 34 should be set to 150Dh.

**Note:** The power monitor resolution for Q3 and Q4 is different from that of Q1, Q2, Q5, and Q6.

Table 24. Associated Power Monitoring and Power Fault Registers

Parameter	Description/ Range	Resolution	Register Bits	Location*
Power Monitor Pointer	0 to 5 points to Q1 to Q6, respectively	N/A	PWRMP[2:0]	Direct Register 76
Line Power Monitor Output	0 to 7.8 W for Q1, Q2, Q5, Q6 0 to 0.9 W for Q3, Q4	30.4 mW 3.62 mW	PWROM[7:0]	Direct Register 77
Power Alarm Threshold, Q1 & Q2	0 to 7.8 W	30.4 mW	PPT12[7:0]	Indirect Register 19
Power Alarm Threshold, Q3 & Q4	0 to 0.9 W	3.62 mW	PPT34[7:0]	Indirect Register 20
Power Alarm Threshold, Q5 & Q6	0 to 7.8 W	30.4 mW	PPT56[7:0]	Indirect Register 21
Thermal LPF Pole, Q1 & Q2	See equation in “2.1.5. Power Monitoring and Line Fault Detection”		NQ12[7:0]	Indirect Register 24
Thermal LPF Pole, Q3 & Q4	See equation in “2.1.5. Power Monitoring and Line Fault Detection”		NQ34[7:0]	Indirect Register 25
Thermal LPF Pole, Q5 & Q6	See equation in “2.1.5. Power Monitoring and Line Fault Detection”		NQ56[7:0]	Indirect Register 26
Power Alarm Interrupt Pending	Bits 2 to 7 correspond to Q1 to Q6, respectively	N/A	QnAP[n+1], where n = 1 to 6	Direct Register 19
Power Alarm Interrupt Enable	Bits 2 to 7 correspond to Q1 to Q6, respectively	N/A	QnAE[n+1], where n = 1 to 6	Direct Register 22
Power Alarm Automatic/Manual Detect	0 = manual mode 1 = enter Open state upon power alarm	N/A	AOPN	Direct Register 67
<p><b>*Note:</b> The ProSLIC device uses registers that are both directly and indirectly mapped. A “direct” register is one that is mapped directly. An “indirect” register is one that is accessed using the indirect access registers (direct registers 28 through 31).</p>				

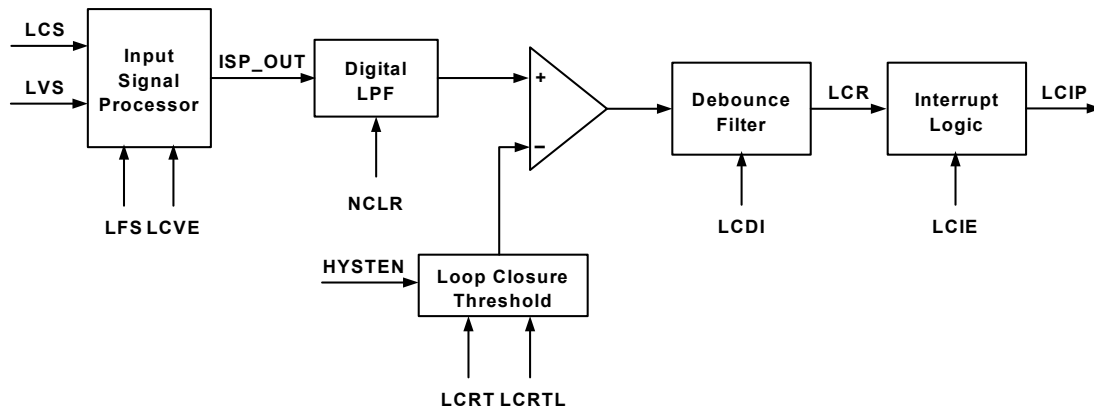

**Figure 18. Loop Closure Detection**

### 2.1.6. Loop Closure Detection

A loop closure event signals that the terminal equipment has gone off-hook during On-Hook Transmission or On-Hook Active states. The ProSLIC performs loop closure detection digitally using its on-chip monitor A/D converter. The functional blocks required to implement loop closure detection are shown in Figure 18. The primary input to the system is the Loop Current Sense value provided in the LCS register (direct Register 79). The LCS value is processed in the Input Signal Processor when the ProSLIC is in the On-Hook Transmission or On-Hook Active Linefeed state, as indicated by the Linefeed Shadow register, LFS[2:0] (direct Register 64). The data then feeds into a programmable digital low-pass filter, which removes unwanted ac signal components before threshold detection.

The output of the low-pass filter is compared to a programmable threshold, LCRT (indirect Register 15). The threshold comparator output feeds a programmable debouncing filter. The output of the debouncing filter remains in its present state unless the input remains in the opposite state for the entire period of time programmed by the loop closure debounce interval, LCDI (direct Register 69). If the debounce interval has been satisfied, the LCR bit will be set to indicate that a valid loop closure has occurred. A loop closure interrupt is generated if enabled by the LCIE bit (direct Register 22). Table 25 lists the registers that must be written or monitored to correctly detect a loop closure condition.

### 2.1.7. Loop Closure Threshold Hysteresis

Programmable hysteresis to the loop closure threshold can be enabled by setting HYSTEN = 1 (direct Register 108, bit 0). The hysteresis is defined by LCRT (indirect Register 15) and LCRTL (indirect Register 66), which set the upper and lower bounds, respectively.

### 2.1.8. Voltage-Based Loop Closure Detection

An optional voltage-based loop closure detection mode is enabled by setting LCVE = 1 (direct Register 108, bit 2). In this mode, the loop voltage is compared to the loop closure threshold register (LCRT), which represents a minimum voltage threshold instead of a maximum current threshold. If hysteresis is also enabled, then LCRT represents the upper voltage boundary and LCRTL represents the lower voltage boundary for hysteresis. Although voltage-based loop closure detection is an option, the default current-based loop closure detection is recommended.

**Table 25. Register Set for Loop Closure Detection**

Parameter	Register	Location
Loop Closure Interrupt Pending	LCIP	Direct Reg.19
Loop Closure Interrupt Enable	LCIE	Direct Reg. 22
Loop Closure Threshold	LCRT[5:0]	Indirect Reg.15
Loop Closure Threshold—Lower	LCRTL[5:0]	Indirect Reg. 66
Loop Closure Filter Coefficient	NCLR[12:0]	Indirect Reg. 22
Loop Closure Detect Status (monitor only)	LCR	Direct Reg. 68
Loop Closure Detect Debounce Interval	LCDI[6:0]	Direct Reg. 69
Hysteresis Enable	HYSTEN	Direct Reg. 108
Voltage-Based Loop Closure	LCVE	Direct Reg. 108



### 2.1.9. Linefeed Calibration

An internal calibration algorithm corrects for internal and external component errors. The calibration is initiated by setting the CAL bit in direct Register 96. Upon completion of the calibration cycle, this bit is automatically reset.

It is recommended that a calibration be executed following system powerup. Upon release of the chip reset, the ProSLIC is in the Open state. After powering up the dc-dc converter and allowing it to settle for time ( $T_{SETTLE}$ ) the calibration can be initiated. Additional calibrations may be performed, but only one calibration should be necessary as long as the system remains powered up.

During calibration,  $V_{BAT}$ ,  $V_{TIP}$ , and  $V_{RING}$  voltages are controlled by the calibration engine to provide the correct external voltage conditions for the algorithm. Calibration should be performed in the On-Hook state. RING or TIP must not be connected to ground during the calibration.

When using the Si3201, automatic calibration routines for RING gain mismatch and TIP gain mismatch should not be performed. Instead of running these two calibrations automatically, consult “AN35: Si321x User’s Quick Reference Guide”, and follow the instructions for manual calibration.

## 2.2. Battery Voltage Generation and Switching

The ProSLIC integrates a dc-dc converter controller that dynamically regulates a single output voltage. This mode eliminates the need to supply large external battery voltages. Instead, it converts a single positive input voltage into the real-time battery voltage needed for any given state according to programmed linefeed parameters.

### 2.2.1. DC-DC Converter General Description

The dc-dc converter dynamically generates the large negative voltages required to operate the linefeed interface. The ProSLIC acts as the controller for a buck-boost dc-dc converter that converts a positive dc voltage into the desired negative battery voltage. In addition to eliminating external power supplies, this allows the ProSLIC to dynamically control the battery voltage to the minimum required for any given mode of operation.

Two different dc-dc circuit options are offered: a BJT/inductor version and a MOSFET/transformer version.

Due to the differences on the driving circuits, there are two different versions of the ProSLIC. The Si321x supports the BJT/inductor circuit option, and the Si321xM version supports the MOSFET solution. The

only difference between the two versions is the polarity of the DCFF pin with respect to the DCDRV pin. For the Si321x, DCDRV and DCFF are opposite polarity. For the Si321xM, DCDRV and DCFF are the same polarity. Table 26 summarizes these differences.

**Table 26. Si321x and Si321xM Differences**

Device	DCFF Signal Polarity	DCPOL
Si321x	= $\overline{\text{DCDRV}}$	0
Si321xM	= DCDRV	1

**Notes:**

- DCFF signal polarity with respect to DCDRV signal.
- Direct Register 93, bit 5; This is a read-only bit.

Extensive design guidance on each of these circuits can be obtained from “AN45: Design Guide for the Si3210 DC-DC Converter” and from an interactive dc-dc converter design spreadsheet. Both of these documents are available on the Silicon Laboratories website ([www.silabs.com](http://www.silabs.com)).

### 2.2.2. BJT/Inductor Circuit Option Using Si321x

The BJT/Inductor circuit option, as defined in Figure 13 on page 23, offers a flexible, low-cost solution. Depending on selected L1 inductance value and the switching frequency, the input voltage ( $V_{DC}$ ) can range from 5 V to 30 V. By nature of a dc-dc converter’s operation, peak and average input currents can become large with small input voltages. Consider this when selecting the appropriate input voltage and power rating for the  $V_{DC}$  power supply.

For this solution, a PNP power BJT (Q7) switches the current flow through low ESR inductor L1. The Si3216 uses the DCDRV and DCFF pins to switch Q7 on and off. DCDRV controls Q7 through NPN BJT Q8. DCFF is ac-coupled to Q7 through capacitor C10 to assist R16 in turning off Q7. Therefore, DCFF must have opposite polarity to DCDRV, and the Si321x (not Si321xM) must be used.

### 2.2.3. MOSFET/Transformer Circuit Option Using Si321xM

The MOSFET/transformer circuit option, as defined in Figure 14 on page 24, offers higher power efficiencies across a larger input voltage range. Depending on the transformer’s primary inductor value and the switching frequency, the input voltage ( $V_{DC}$ ) can range from 3.3 V to 35 V. Therefore, it is possible to power the entire ProSLIC solution from a single 3.3 V or 5 V power supply. By nature of a dc-dc converter’s operation, peak and average input currents can become large with small input voltages. Consider this when selecting the appropriate input voltage and power rating for the  $V_{DC}$

power supply (number of REN supported).

For this solution, an n-channel power MOSFET (M1) switches the current flow through a power transformer T1. T1 is specified in “AN45: Design Guide for the Si3210/15/16 DC-DC Converter” and includes several taps on the primary side to facilitate a wide range of input voltages. The “M” version of the ProSLIC must be used for the application circuit depicted in Figure 14 on page 24 because the DCFF pin is used to drive M1 directly and, therefore, must be the same polarity as DCDRV. DCDRV is not used in this circuit option; connecting DCFF and DCDRV together is not recommended.

#### 2.2.4. DC-DC Converter Architecture

The control logic for a pulse-width modulated (PWM) dc-dc converter is incorporated in the ProSLIC. Output pins DCDRV and DCFF are used to switch a bipolar transistor or MOSFET. The polarity of DCFF is opposite that of DCDRV.

The dc-dc converter circuit is powered on when the DCOF bit in the powerdown register (direct Register 14, bit 4) is cleared to 0. The switching regulator circuit within the ProSLIC is a high-performance, pulse-width modulation controller. The control pins are driven by the PWM controller logic in the ProSLIC. The regulated output voltage ( $V_{BAT}$ ) is sensed by the SVBAT pin and used to detect whether the output voltage is above or below an internal reference for the desired battery voltage. The dc monitor pins SDCH and SDCL monitor input current and voltage to the dc-dc converter external circuitry. If an overload condition is detected, the PWM controller will turn off the switching transistor for the remainder of a PWM period to prevent damage to external components. It is important that the proper value of R18 be selected to ensure safe operation. Guidance is given in “AN45: Design Guide for the Si3210/15/16 DC-DC Converter”.

The PWM controller operates at a frequency set by the dc-dc Converter PWM register (direct Register 92). During a PWM period the outputs of the control pins DCDRV and DCFF are asserted for a time given by the read-only PWM Pulse Width register (direct Register 94).

The dc-dc converter must be off for some time in each cycle to allow the inductor or transformer to transfer its stored energy to the output capacitor, C9. This minimum off time can be set through the dc-dc Converter Switching Delay register, (direct Register 93). The number of 16.384 MHz clock cycles that the controller is off is equal to DCTOF (bits 0 through 4) plus 4. If the dc monitor pins detect an overload condition, the dc-dc converter interrupts its conversion cycles regardless of

the register settings to prevent component damage. These inputs should be calibrated by writing the DCCAL bit (bit 7) of the dc-dc Converter Switching Delay register, direct Register 93, after the dc-dc converter has been turned on.

Because the ProSLIC dynamically regulates its own battery supply voltage using the dc-dc converter controller, the battery voltage ( $V_{BAT}$ ) is offset from the negative-most terminal by a programmable voltage ( $V_{OV}$ ) to allow voltage headroom for carrying audio signals.

As mentioned previously, the ProSLIC dynamically adjusts  $V_{BAT}$  to suit the particular circuit requirement. To illustrate this, the behavior of  $V_{BAT}$  in the Active state is shown in Figure 19. In the Active state, the TIP-to-RING open circuit voltage is kept at  $V_{OC}$  in the constant voltage region while the regulator output voltage,  $V_{BAT} = V_{CM} + V_{OC} + V_{OV}$ .

When the loop current attempts to exceed  $I_{LIM}$ , the dc line driver circuit enters constant current mode allowing the TIP to RING voltage to track  $R_{LOOP}$ . As the TIP terminal is kept at a constant voltage, it is the RING terminal voltage that tracks  $R_{LOOP}$  and, as a result, the  $|V_{BAT}|$  voltage will also track  $R_{LOOP}$ . In this state,  $|V_{BAT}| = I_{LIM} \times R_{LOOP} + V_{CM} + V_{OV}$ . As  $R_{LOOP}$  decreases below the  $V_{OC}/I_{LIM}$  mark, the regulator output voltage can continue to track  $R_{LOOP}$  (TRACK = 1), or the  $R_{LOOP}$  tracking mechanism is stopped when  $|V_{BAT}| = |V_{BATL}|$  (TRACK = 0). The former case is the more common application and provides the maximum power dissipation savings. In principle, the regulator output voltage can go as low as  $|V_{BAT}| = V_{CM} + V_{OV}$ , offering significant power savings.

When TRACK = 0,  $|V_{BAT}|$  does not decrease below  $V_{BATL}$ . The RING terminal voltage, however, continues to decrease with decreasing  $R_{LOOP}$ . The power dissipation on the NPN bipolar transistor driving the RING terminal can become large and may require a higher power rating device. The non-tracking mode of operation is required by specific terminal equipment which, in order to initiate certain data transmission modes, goes briefly on-hook to measure the line voltage to determine whether there is any other off-hook terminal equipment on the same line. TRACK = 0 mode is desired since the regulator output voltage has long settling time constants (tens of milliseconds) and cannot change rapidly for TRACK = 1 mode. Therefore, the brief on-hook voltage measurement would yield approximately the same voltage as the off-hook line voltage and would cause the terminal equipment to incorrectly sense another off-hook terminal.

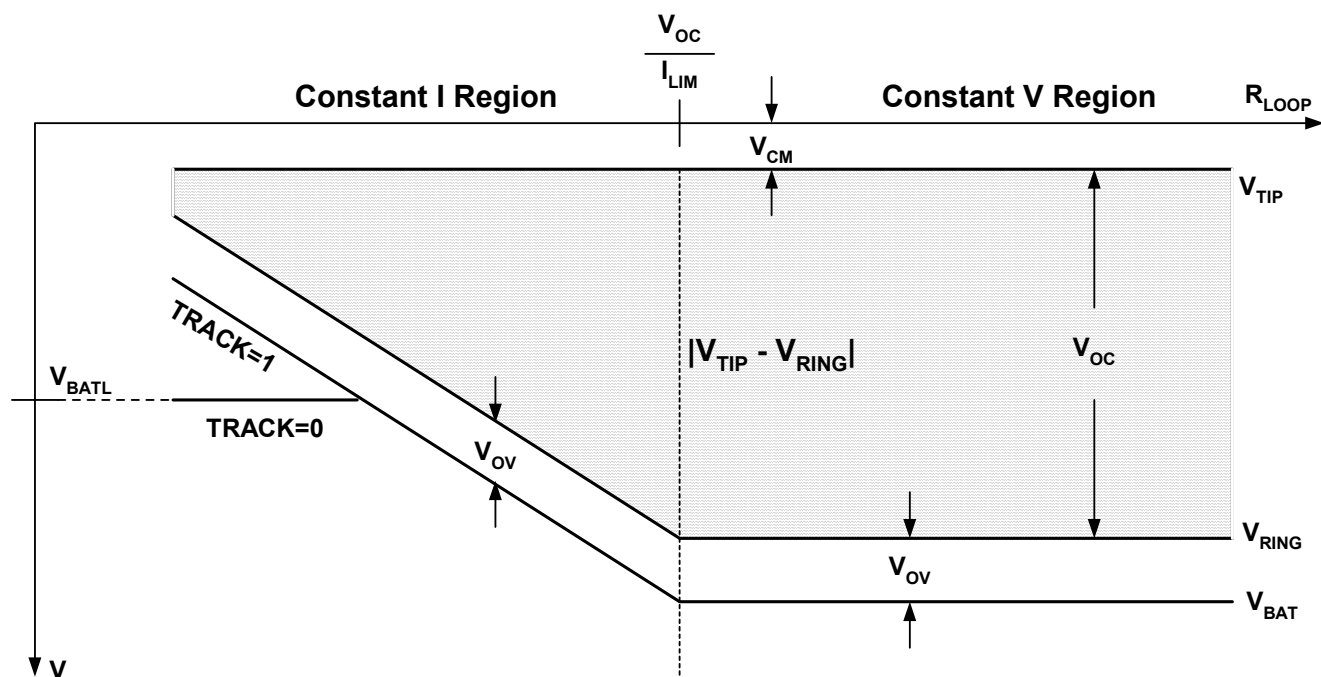

Figure 19.  $V_{TIP}$ ,  $V_{RING}$  and  $V_{BAT}$  in the Forward Active State

Table 27. Associated Relevant DC-DC Converter Registers

Parameter	Range	Resolution	Register Bit	Location
DC-DC Converter Power-Off Control	N/A	N/A	DCOF	Direct Register 14
DC-DC Converter Calibration Enable/Status	N/A	N/A	DCCAL	Direct Register 93
DC-DC Converter PWM Period	0 to 15.564 $\mu$ s	61.035 ns	DCN[7:0]	Direct Register 92
DC-DC Converter Min. Off Time	(0 to 1.892 $\mu$ s) + 4 ns	61.035 ns	DCTOF[4:0]	Direct Register 93
High Battery Voltage— $V_{BATH}$	0 to -94.5 V	1.5 V	VBATH[5:0]	Direct Register 74
Low Battery Voltage— $V_{BATL}$	0 to -94.5 V	1.5 V	VBATL[5:0]	Direct Register 75
$V_{OV}$	0 to -9 V or 0 to -13.5 V	1.5 V	VMIND[3:0] VOV	Indirect Register 64 Direct Register 66

**Note:** The ProSLIC uses registers that are both directly and indirectly mapped. A “direct” register is one that is mapped directly. An “indirect” register is one that is accessed using the indirect access registers (direct registers 28 through 31).

## 2.2.5. DC-DC Converter Enhancements

The ProSLIC supports two selectable enhancements to the dc-dc converter. The first is a multi-threshold error control algorithm that enables the dc-dc converter to adjust more quickly to voltage changes. This option is enabled by setting  $DCSU = 1$  (direct Register 108, bit 5). The second enhancement is an audio band filter that removes audio band noise from the dc-dc converter control loop. This option is enabled by setting  $DCFIL = 1$  (direct Register 108, bit 1).

## 2.2.6. DC-DC Converter During Ringing

When the ProSLIC enters the Ringing state, it requires voltages well above those used in the active mode. The voltage to be generated and regulated by the dc-dc converter during a ringing burst is set using the  $V_{BATH}$  register (direct Register 74).  $V_{BATH}$  can be set between 0 and  $-94.5\text{ V}$  in  $1.5\text{ V}$  steps. To avoid clipping the ringing signal,  $V_{BATH}$  must be set larger than the ringing amplitude. At the end of each ringing burst the dc-dc converter adjusts back to active state regulation as

described above.

## 2.3. Tone Generation

Two digital tone generators are provided in the ProSLIC. They allow the generation of a wide variety of single or dual tone frequency and amplitude combinations and spare the user the effort of generating the required POTS signaling tones on the PCM highway. DTMF, FSK (caller ID), call progress, and other tones can all be generated on-chip. The tones can be sent to either the receive or transmit paths. (See Figure 24 on page 44.)

### 2.3.1. Tone Generator Architecture

A simplified diagram of the tone generator architecture is shown in Figure 20. The oscillator, active/inactive timers, interrupt block, and signal routing block are connected to give the user flexibility in creating audio signals. Control and status register bits are placed in the figure to indicate their association with the tone generator architecture. These registers are described in more detail in Table 28 on page 38.

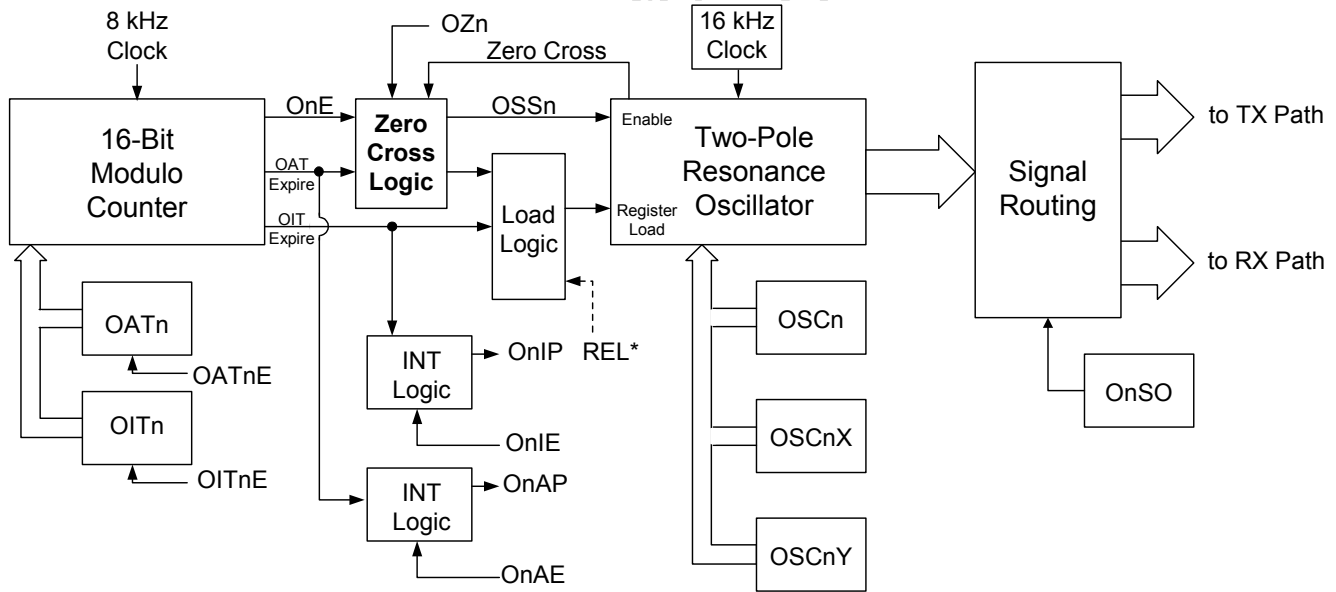

\*Tone Generator 1 Only  
 n = "1" or "2" for Tone Generator 1 and 2, respectively

**Figure 20. Simplified Tone Generator Diagram**

### 2.3.2. Oscillator Frequency and Amplitude

Each of the two-tone generators contains a two-pole resonant oscillator circuit with a programmable frequency and amplitude. These two-tone generators are programmed via indirect registers OSC1, OSC1X, OSC1Y, OSC2, OSC2X, and OSC2Y. The sample rate for the two oscillators is 16 kHz. The equations are as follows:

$$\text{coeff}_n = \cos(2\pi f_n / 16 \text{ kHz}),$$

where  $f_n$  is the frequency to be generated;

$$\text{OSC}_n = \text{coeff}_n \times (2^{15});$$

$$\text{OSC}_n\text{X} = \frac{1}{4} \times \sqrt{\frac{1 - \text{coeff}}{1 + \text{coeff}}} \times (2^{15} - 1) \times \frac{\text{Desired } V_{\text{rms}}}{1.11 V_{\text{rms}}}$$

where desired  $V_{\text{rms}}$  is the amplitude to be generated;

$$\text{OSC}_n\text{Y} = 0,$$

$n = 1$  or  $2$  for oscillator 1 or oscillator 2, respectively.

For example, to generate a DTMF digit of 8, the two required tones are 852 Hz and 1336 Hz. Assuming the generation of half-scale values (ignoring twist) is desired, the following values are calculated:

$$\text{coeff}_1 = \cos\left(\frac{2\pi 852}{16000}\right) = 0.94455$$

$$\text{OSC}_1 = 0.94455(2^{15}) = 30951 = 78\text{E6h}$$

$$\text{OSC}_1\text{X} = \frac{1}{4} \times \sqrt{\frac{0.05545}{1.94455}} \times (2^{15} - 1) \times 0.5 = 692 = 2\text{B3h}$$

$$\text{OSC}_1\text{Y} = 0$$

$$\text{coeff}_2 = \cos\left(\frac{2\pi 1336}{16000}\right) = 0.86550$$

$$\text{OSC}_2 = 0.86550(2^{15}) = 28361 = 6\text{EC8h}$$

$$\text{OSC}_2\text{X} = \frac{1}{4} \times \sqrt{\frac{0.13450}{1.86550}} \times (2^{15} - 1) \times 0.5 = 1098 = 44\text{Bh}$$

$$\text{OSC}_2\text{Y} = 0$$

The above computed values are written to the corresponding registers to initialize the oscillators. Once the oscillators are initialized, the oscillator control registers can be accessed to enable the oscillators and direct their outputs.

### 2.3.3. Tone Generator Cadence Programming

Each of the two-tone generators contains two timers, one for setting the active period and one for setting the inactive period. The oscillator signal is generated during the active period and suspended during the inactive period. Both the active and inactive periods can be programmed from 0 to 8 seconds in 125  $\mu\text{s}$  steps. The active period time interval is set using OAT1 (direct registers 36 and 37) for tone generator 1 and OAT2 (direct registers 40 and 41) for tone generator 2.

To enable automatic cadence for tone generator 1, define the OAT1 and OIT1 registers and then set the O1TAE bit (direct Register 32, bit 4) and O1TIE bit (direct Register 32, bit 3). This enables each of the timers to control the state of the Oscillator Enable bit, O1E (direct Register 32, bit 2). The 16-bit counter begins counting until the active timer expires, at which time the 16-bit counter resets to zero and begins counting until the inactive timer expires. The cadence continues until the user clears the O1TAE and O1TIE control bits. The zero crossing detect feature can be implemented by setting the OZ1 bit (direct Register 32, bit 5). This ensures that each oscillator pulse ends without a dc component. The timing diagram in Figure 21 is an example of an output cadence using the zero crossing feature.

One-shot oscillation can be achieved by enabling O1E and O1TAE. Direct control over the cadence can be achieved by controlling the O1E bit (direct Register 32, bit 2) directly if O1TAE and O1TIE are disabled.

The operation of tone generator 2 is identical to that of tone generator 1 using its respective control registers.

**Note:** Tone Generator 2 should not be enabled simultaneously with the ringing oscillator due to resource sharing within the hardware.

Continuous phase frequency-shift keying (FSK) waveforms may be created using tone generator 1 (not available on tone generator 2) by setting the REL bit (direct Register 32, bit 6), which enables reloading of the OSC1, OSC1X, and OSC1Y registers at the expiration of the active timer (OAT1).

**Table 28. Associated Tone Generator Registers**

Tone Generator 1			
Parameter	Description/Range	Register Bits	Location
Oscillator 1 Frequency Coefficient	Sets oscillator frequency	OSC1[15:0]	Indirect Register 0
Oscillator 1 Amplitude Coefficient	Sets oscillator amplitude	OSC1X[15:0]	Indirect Register 1
Oscillator 1 initial phase coefficient	Sets initial phase	OSC1Y[15:0]	Indirect Register 2
Oscillator 1 Active Timer	0 to 8 s	OAT1[15:0]	Direct Registers 36 & 37
Oscillator 1 Inactive Timer	0 to 8 s	OIT1[15:0]	Direct Registers 38 & 39
Oscillator 1 Control	Status and control registers	OSS1, REL, OZ1, O1TAE, O1TIE, O1E, O1SO[1:0]	Direct Register 32
Tone Generator 2			
Parameter	Description/Range	Register	Location
Oscillator 2 Frequency Coefficient	Sets oscillator frequency	OSC2[15:0]	Indirect Register 3
Oscillator 2 Amplitude Coefficient	Sets oscillator amplitude	OSC2X[15:0]	Indirect Register 4
Oscillator 2 initial phase coefficient	Sets initial phase	OSC2Y[15:0]	Indirect Register 5
Oscillator 2 Active Timer	0 to 8 s	OAT2[15:0]	Direct Registers 40 & 41
Oscillator 2 Inactive Timer	0 to 8 s	OIT2[15:0]	Direct Registers 42 & 43
Oscillator 2 Control	Status and control registers	OSS2, OZ2, O2TAE, O2TIE, O2E, O2SO[1:0]	Direct Register 33

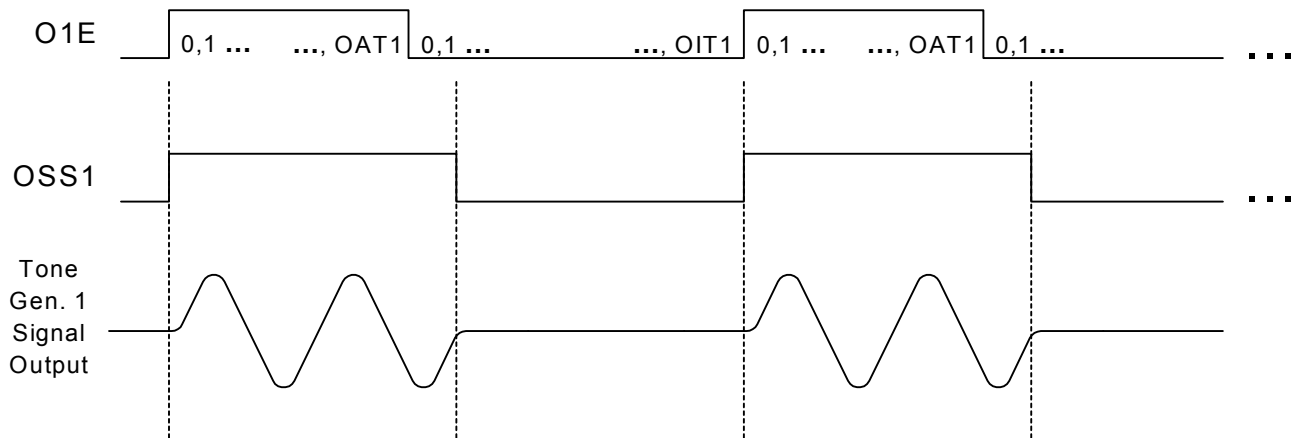

**Figure 21. Tone Generator Timing Diagram**

### 2.3.4. Enhanced FSK Waveform Generation

Enhanced FSK generation capabilities can be enabled by setting FSKEN = 1 (direct Register 108, bit 6) and REN = 1 (direct Register 32, bit 6). In this mode, the user can define mark (1) and space (0) attributes once during initialization by defining indirect Registers 69–74. The user need only indicate 0-to-1 and 1-to-0 transitions in the information stream. By writing to FSKDAT (direct Register 52), this mode applies a 24 kHz sample rate to tone generator 1 to give additional resolution to timers and frequency generation. “AN32: Si321x Frequency Shift Keying (FSK) Modulation” gives detailed instructions on how to implement FSK in this mode. Additionally, sample source code is available from Silicon Laboratories upon request.

### 2.3.5. Tone Generator Interrupts

Both the active and inactive timers can generate their own interrupt to signal “on/off” transitions to the software. The timer interrupts for tone generator 1 can be individually enabled by setting the O1AE and O1IE bits (direct Register 21, bits 0 and 1, respectively). Timer interrupts for tone generator 2 are O2AE and O2IE (direct Register 21, bits 2 and 3, respectively). A pending interrupt for each of the timers is determined by reading the O1AP, O1IP, O2AP, and O2IP bits in the Interrupt Status 1 register (direct Register 18, bits 0 through 3, respectively).

## 2.4. Ringing Generation

The ProSLIC provides fully-programmable internal balanced ringing with or without a dc offset to ring a wide variety of terminal devices. All parameters associated with ringing are software-programmable: ringing frequency, waveform, amplitude, dc offset, and ringing cadence. Both sinusoidal and trapezoidal ringing waveforms are supported, and the trapezoidal crest factor is programmable. Ringing signals of up to 90 V peak or more can be generated, enabling the ProSLIC to drive a 5 REN (1380  $\Omega$  + 40  $\mu$ F) ringer load across loop lengths of 2000 feet (160  $\Omega$ ) or more.

### 2.4.1. Ringing Architecture

The ringing generator architecture is nearly identical to that of the tone generator. The sinusoid ringing waveform is generated using an internal two-pole resonance oscillator circuit with programmable frequency and amplitude. However, since ringing frequencies are very low compared to the audio band signaling frequencies, the ringing waveform is generated at a 1 kHz rate instead of 8 kHz.

The ringing generator has two timers that function the same as for the tone generator timers. They allow on/off cadence settings up to 8 seconds on/ 8 seconds off. In addition to controlling ringing cadence, these timers control the transition into and out of the Ringing state. Table 29 summarizes the list of registers used for ringing generation.

**Note:** Tone generator 2 should not be enabled concurrently with the ringing generator due to resource sharing within the hardware.

When the Ringing state is invoked by writing LF[2:0] = 100 (direct Register 64), the ProSLIC goes into the Ringing state and starts the first ring. At the expiration of RAT, the ProSLIC turns off the ringing waveform and goes to the on-hook transmission state. Upon expiration of RIT, ringing again initiates. This process continues as long as the two timers are enabled and the Linefeed Control register is set to the Ringing state.

Table 29. Registers for Ringing Generation

Parameter	Range/ Description	Register Bits	Location
Ringing Waveform	Sine/Trapezoid	TSWS	Direct Register 34
Ringing Voltage Offset Enable	Enabled/ Disabled	RVO	Direct Register 34
Ringing Active Timer Enable	Enabled/ Disabled	RTAE	Direct Register 34
Ringing Inactive Timer Enable	Enabled/ Disabled	RTIE	Direct Register 34
Ringing Oscillator Enable	Enabled/ Disabled	ROE	Direct Register 34
Ringing Oscillator Active Timer	0 to 8 s	RAT[15:0]	Direct Registers 48 and 49
Ringing Oscillator Inactive Timer	0 to 8 s	RIT[15:0]	Direct Registers 50 and 51
Linefeed Control (Initiates Ringing State)	Ringing State = 100 <sub>b</sub>	LF[2:0]	Direct Register 64
High Battery Voltage	0 to -94.5 V	VBATH[5:0]	Direct Register 74
Ringing dc voltage offset	0 to 94.5 V	ROFF[15:0]	Indirect Register 6
Ringing frequency	15 to 100 Hz	RCO[15:0]	Indirect Register 7
Ringing amplitude	0 to 94.5 V	RNGX[15:0]	Indirect Register 8
Ringing initial phase	Sets initial phase for sinewave and period for trapezoid	RNGY[15:0]	Indirect Register 9
Common Mode Bias Adjust During Ringing	0 to 22.5 V	VCMR[3:0]	Indirect Register 27
<b>Note:</b> The ProSLIC uses registers that are both directly and indirectly mapped. A “direct” register is one that is mapped directly. An “indirect” register is one that is accessed using the indirect access registers (direct registers 28 through 31).			

#### 2.4.2. Sinusoidal Ringing

To configure the ProSLIC for sinusoidal ringing, the frequency and amplitude are initialized by writing to the following indirect registers: RCO, RNGX, and RNGY. The equations for RCO, RNGX, RNGY are as follows:

$$RCO = \text{coeff} \times (2^{15})$$

where

$$\text{coeff} = \cos\left(\frac{2\pi f}{1000 \text{ Hz}}\right)$$

and f = desired ringing frequency in hertz.

$$RNGX = \frac{1}{4} \cdot \sqrt{\frac{1 - \text{coeff}}{1 + \text{coeff}}} \times 2^{15} \times \frac{\text{Desired } V_{PK}(0 \text{ to } 94.5 \text{ V})}{96 \text{ V}}$$

$$RNGY = 0$$

In selecting a ringing amplitude, the peak TIP-to-RING ringing voltage must be greater than the selected on-hook line voltage setting (VOC, direct Register 72). For example, to generate a 70 V<sub>PK</sub> 20 Hz ringing signal, the

equations are as follows:

$$\text{coeff} = \cos\left(\frac{2\pi \times 20}{1000 \text{ Hz}}\right) = 0.99211$$

$$RCO = 0.99211 \times (2^{15}) = 32509 = 7EFDh$$

$$RNGX = \frac{1}{4} \cdot \sqrt{\frac{0.00789}{1.99211}} \times 2^{15} \times \frac{70}{96} = 376 = 0177h$$

$$RNGY = 0$$

In addition, the user must select the sinusoidal ringing waveform by writing TSWS = 0 (direct Register 34, bit 0).

#### 2.4.3. Trapezoidal Ringing

In addition to the sinusoidal ringing waveform, the ProSLIC supports trapezoidal ringing. Figure 22 illustrates a trapezoidal ringing waveform with offset V<sub>ROFF</sub>.



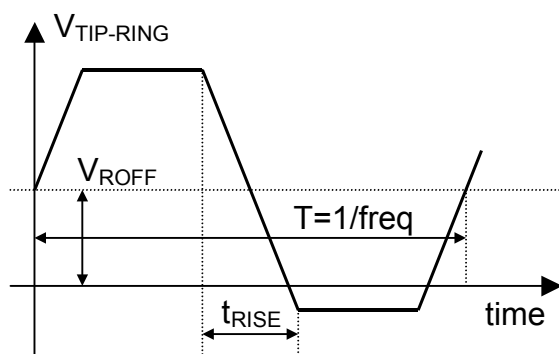

**Figure 22. Trapezoidal Ringing Waveform**

To configure the ProSLIC for trapezoidal ringing, the user should follow the same basic procedure as in the Sinusoidal Ringing section, but using the following equations:

$$\text{RNGY} = \frac{1}{2} \times \text{Period} \times 8000$$

$$\text{RNGX} = \frac{\text{Desired } V_{\text{PK}}}{96 \text{ V}} \times (2^{15})$$

$$\text{RCO} = \frac{2 \times \text{RNGX}}{t_{\text{RISE}} \times 8000}$$

RCO is a value which is added or subtracted from the waveform to ramp the signal up or down in a linear fashion. This value is a function of rise time, period, and amplitude, where rise time and period are related through the following equation for the crest factor of a trapezoidal waveform.

$$t_{\text{RISE}} = \frac{3}{4} T \left( 1 - \frac{1}{\text{CF}^2} \right)$$

where T = ringing period, and CF = desired crest factor.

For example, to generate a 71 V<sub>PK</sub>, 20 Hz ringing signal, the equations are as follows:

$$\text{RNGY}(20 \text{ Hz}) = \frac{1}{2} \times \frac{1}{20 \text{ Hz}} \times 8000 = 200 = \text{C8h}$$

$$\text{RNGX}(71 \text{ V}_{\text{PK}}) = \frac{71}{96} \times 2^{15} = 24235 = \text{5EABh}$$

For a crest factor of 1.3 and a period of 0.05 s (20 Hz), the rise time requirement is 0.0153 s.

$$\begin{aligned} \text{RCO}(20 \text{ Hz}, 1.3 \text{ crest factor}) \\ = \frac{2 \times 24235}{0.0153 \times 8000} = 396 = \text{018Ch} \end{aligned}$$

In addition, the user must select the trapezoidal ringing waveform by writing TSWS = 1 in direct Register 34.

#### 2.4.4. Ringing DC Voltage Offset

A dc offset can be added to the ac ringing waveform by defining the offset voltage in ROFF (indirect Register 6). The offset, V<sub>ROFF</sub>, is added to the ringing signal when RVO is set to 1 (direct Register 34, bit 1). The value of ROFF is calculated as follows:

$$\text{ROFF} = \frac{V_{\text{ROFF}}}{96} \times 2^{15}$$

#### 2.4.5. Linefeed Considerations During Ringing

Care must be taken to keep the generated ringing signal within the ringing voltage rails (GNDA and V<sub>BAT</sub>) to maintain proper biasing of the external bipolar transistors. If the ringing signal nears the rails, a distorted ringing signal and excessive power dissipation in the external transistors will result.

To prevent this invalid operation, set the V<sub>BATH</sub> value (direct Register 74) to a value higher than the maximum peak ringing voltage. The discussion below outlines the considerations and equations that govern the selection of the V<sub>BATH</sub> setting for a particular desired peak ringing voltage.

First, the required amount of ringing overhead voltage, V<sub>OVR</sub>, is calculated based on the maximum value of current through the load, I<sub>LOAD,PK</sub>, the minimum current gain of Q5 and Q6, and a reasonable voltage required to keep Q5 and Q6 out of saturation. For ringing signals up to V<sub>PK</sub> = 87 V, V<sub>OVR</sub> = 7.5 V is a safe value. However, to determine V<sub>OVR</sub> for a specific case, use the equations below.

$$I_{\text{LOAD,PK}} = \frac{V_{\text{AC,PK}}}{R_{\text{LOAD}}} + I_{\text{OS}} = V_{\text{AC,PK}} \times \left( \frac{N_{\text{REN}}}{6.9 \text{ k}\Omega} + I_{\text{OS}} \right)$$

where:

N<sub>REN</sub> is the ringing REN load (max value = 5),

I<sub>OS</sub> is the offset current flowing in the line driver circuit (max value = 2 mA), and

V<sub>AC,PK</sub> = amplitude of the ac ringing waveform.

It is good practice to provide a buffer of a few more milliamperes for I<sub>LOAD,PK</sub> to account for possible line leakages, etc. The total I<sub>LOAD,PK</sub> current should be smaller than 80 mA.

$$V_{\text{OVR}} = I_{\text{LOAD,PK}} \times \frac{\beta + 1}{\beta} \times 80.6 \Omega + 1 \text{ V}$$

where β is the minimum expected current gain of transistors Q5 and Q6.

The minimum value for V<sub>BATH</sub> is, therefore, given by the following equation:

$$V_{\text{BATH}} = V_{\text{AC,PK}} + V_{\text{ROFF}} + V_{\text{OVR}}$$

The ProSLIC is designed to create a fully-balanced ringing waveform, meaning that the TIP and RING common mode voltage,  $(V_{\text{TIP}} + V_{\text{RING}})/2$ , is fixed. This voltage is referred to as  $V_{\text{CM\_RING}}$  and is automatically set to the following:

$$V_{\text{CM\_RING}} = \frac{V_{\text{BATH}} - V_{\text{CMR}}}{2}$$

$V_{\text{CMR}}$  is an indirect register, which provides the headroom by the ringing waveform with respect to the  $V_{\text{BATH}}$  rail. The value is set as a 4-bit setting in indirect Register 27 with an LSB voltage of 1.5 V/LSB. Register 27 should be set with the calculated  $V_{\text{OVR}}$  to provide voltage headroom during ringing.

The ProSLIC has a mode to briefly increase the maximum differential current limit between the voltage transition of TIP and RING from ringing to a dc linefeed state. This mode is enabled by setting  $I_{\text{LIMEN}} = 1$  (direct Register 108, bit 7).

### 2.4.6. Ring Trip Detection

A ring trip event signals that the terminal equipment has gone off-hook during the Ringing state. The ProSLIC performs ring trip detection digitally using its on-chip A/D converter. The functional blocks required to implement ring trip detection are shown in Figure 23.

The primary input to the system is the Loop Current Sense (LCS) value provided by the current monitoring circuitry and reported in direct Register 79. LCS data is processed by the input signal processor when the ProSLIC is in the Ringing state as indicated by the Linefeed Shadow register (direct Register 64). The data then feeds into a programmable digital low pass filter, which removes unwanted ac signal components before threshold detection.

The output of the low-pass filter is compared to a programmable threshold, RPTP (indirect Register 16). The threshold comparator output feeds a programmable debouncing filter. The output of the debouncing filter remains in its present state unless the input remains in the opposite state for the entire period of time programmed by the ring trip debounce interval, RTDI[6:0] (direct Register 70). If the debounce interval has been satisfied, the RTP bit of direct Register 68 will be set to indicate that a valid ring trip has occurred. A ring trip interrupt is generated if enabled by the RTIE bit (direct Register 22). Table 30 lists the registers that must be written or monitored to correctly detect a ring trip condition.

The recommended values for RPTP, NRTP, and RTDI vary according to the programmed ringing frequency. Register values for various ringing frequencies are given in Table 31.

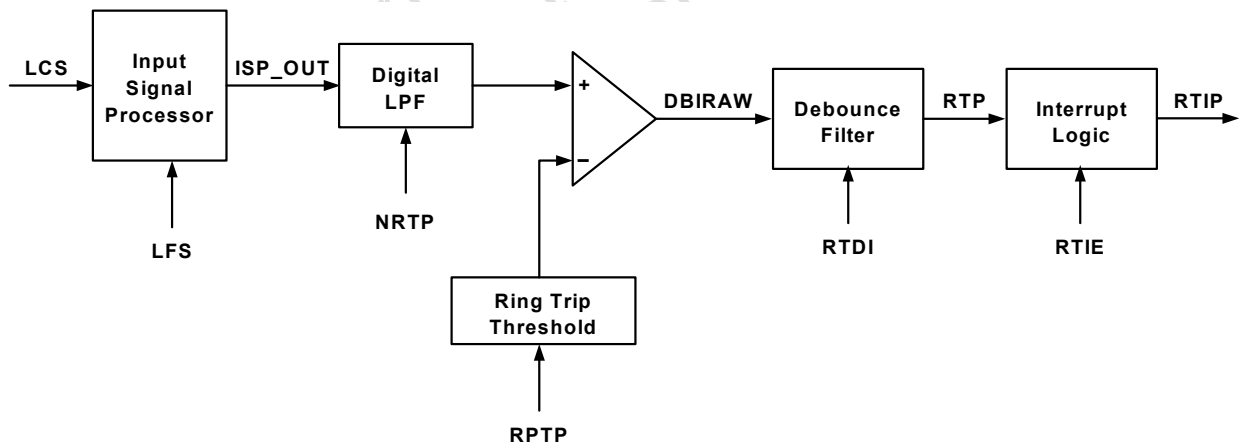

Figure 23. Ring Trip Detector

Table 30. Associated Registers for Ring Trip Detection

Parameter	Register	Location
Ring Trip Interrupt Pending	RTIP	Direct Register 19
Ring Trip Interrupt Enable	RTIE	Direct Register 22
Ring Trip Detect Debounce Interval	RTDI[6:0]	Direct Register 70
Ring Trip Threshold	RPTP[5:0]	Indirect Register 16
Ring Trip Filter Coefficient	NRTP[12:0]	Indirect Register 23
Ring Trip Detect Status (monitor only)	RTP	Direct Register 68

**Note:** The ProSLIC uses registers that are both directly and indirectly mapped. A “direct” register is one that is mapped directly. An “indirect” register is one that is accessed using the indirect access registers (direct registers 28 through 31).

Table 31. Recommended Ring Trip Values for Ringing

Ringing Frequency	NRTP		RPTP		RTDI	
	decimal	hex	decimal	hex	decimal	hex
Hz						
16.667	64	0200	34 mA	3600	15.4 ms	0F
20	100	0320	34 mA	3600	12.3 ms	0B
30	112	0380	34 mA	3600	8.96 ms	09
40	128	0400	34 mA	3600	7.5 ms	07
50	213	06A8	34 mA	3600	5 ms	05
60	256	0800	34 mA	3600	4.8 ms	05

## 2.5. Audio Path

Unlike traditional SLICs, the codec function is integrated into the ProSLIC. The 16-bit codec offers software-selectable 200 Hz to 3.4 kHz narrowband and 50 Hz to 7 kHz (Si3216 only) wideband audio modes, programmable gain/attenuation blocks, and several loop-back modes. The signal path block diagram is shown in Figure 24.

### 2.5.1. Transmit Path

In the transmit path, the analog signal fed by the external ac coupling capacitors is amplified by the analog transmit amplifier, ATX, prior to the A/D converter. ATX has the following gain options: mute, -3.5, 0, and 3.5 dB. The main role of ATX is to coarsely adjust the signal swing to be as close as possible to the full-scale input of the A/D converter to maximize the signal-to-

noise ratio of the transmit path. After passing through an anti-aliasing filter, the analog signal is processed by the A/D converter, producing a 16-bit wide, linear PCM data stream. The standard requirements for transmit path attenuation for signal frequencies above the audio band are implemented as part of the combined decimation filter characteristic of the A/D converter. An additional filter, THPF, implements the high-pass attenuation requirements for signals below 50 Hz. The linear PCM data stream output from THPF is amplified by the transmit-path programmable gain amplifier, ADCG, which can be programmed from  $-\infty$  dB to 6 dB. The final step in the transmit path signal processing is the user-selectable A-law or  $\mu$ -law compression block. In narrowband mode,  $\mu$ -law or A-law compression can be selected to reduce the data stream word width to 8 bits.

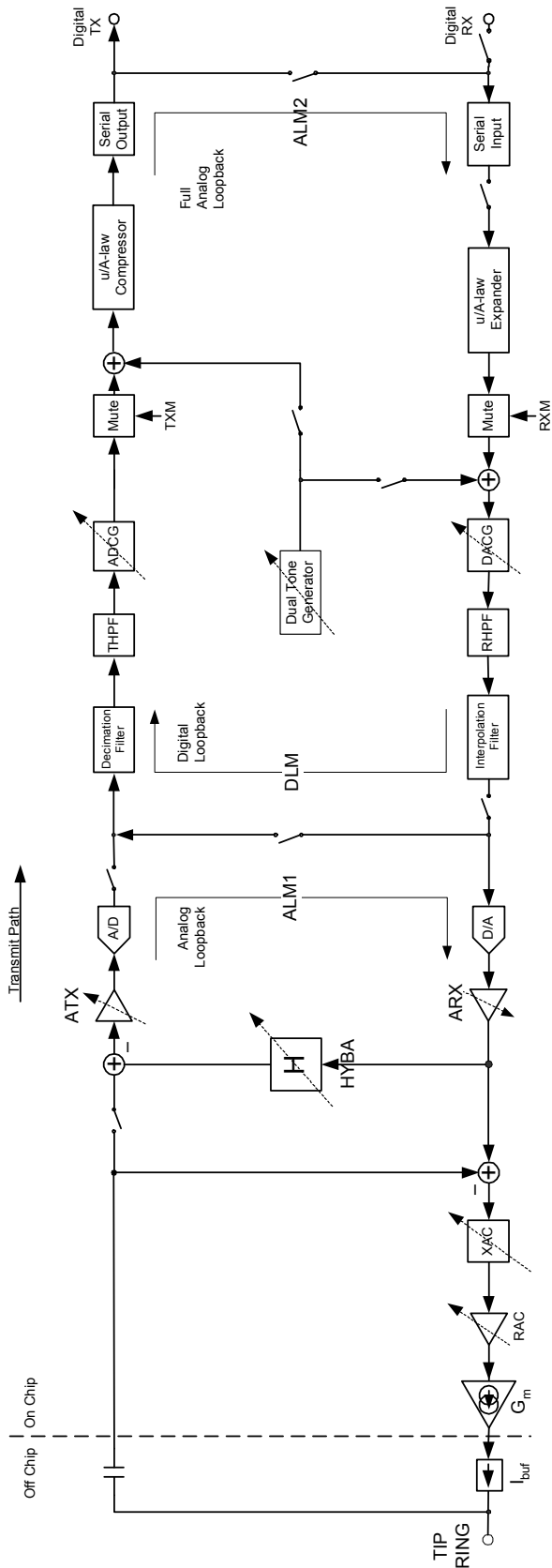

Figure 24. AC Signal Path Block Diagram

### 2.5.2. Receive Path

In the receive path, digital voice is expanded from  $\mu$ /A-law if enabled. DACG is the receive path programmable gain amplifier which can be programmed from  $-\infty$  dB to 6 dB. A 16-bit signal is then provided to a D/A converter. The resulting analog signal is amplified by the analog receive amplifier, ARX, which has the following gain options: mute,  $-3.5$ , 0, and 3.5 dB. It is then applied at the input of the transconductance amplifier ( $G_m$ ), which drives the off-chip current buffer ( $I_{BUF}$ ).

### 2.5.3. Companding

The ProSLIC supports both  $\mu$ -255 law and A-law companding formats when narrowband mode is selected.  $\mu$ -255 law is more commonly used in North America and Japan, while A-law is used primarily in Europe. Data format is selected using the PCMF register. Tables 32 and 33 define  $\mu$ -law and A-law formats, respectively.

The dominant source of distortion and noise in both the transmit and receive paths is the quantization noise introduced by the  $\mu$ -law or the A-law compression process. Figure 3 on page 11 specifies the minimum signal-to-noise and distortion ratio for either path for a sine wave input of 200 Hz to 3400 Hz.

Both  $\mu$ -law and A-law speech encoding allow the audio codec to transfer and process audio signals larger than 0 dBm0 without clipping. The maximum PCM code is generated for a  $\mu$ -law encoded sine wave of 3.17 dBm0 or an A-law encoded sine wave of 3.14 dBm0. The ProSLIC overload clipping limits are driven by the PCM encoding process. Figure 4 on page 11 shows the acceptable limits for the analog-to-analog fundamental power transfer function, which bounds the behavior of ProSLIC.

### 2.5.4. Transhybrid Balance

The ProSLIC provides programmable transhybrid balance with gain block H. (See Figure 24.) In the ideal case where the synthesized SLIC impedance exactly matches the subscriber loop impedance, the transhybrid balance should be set to subtract a  $-6$  dB level from the transmit path signal. The transhybrid balance gain can be adjusted from  $-2.77$  dB to  $+4.08$  dB around the ideal setting of  $-6$  dB by programming the HYBA[2:0] bits of the Hybrid Control register (direct Register 11). Adjusting any of the analog or digital gain blocks does not require any modification of the transhybrid balance gain block, as the transhybrid gain is subtracted from the transmit path signal prior to any gain adjustment stages. The transhybrid balance can also be disabled, if desired, using the appropriate register setting.

### 2.5.5. Loopback Testing

Four loopback test options are available in the ProSLIC:

- The full analog loopback (ALM2) tests almost all the circuitry of both the transmit and receive paths. The transmit data stream is fed back serially to the input of the receive path expander. (See Figure 24.) The signal path starts with the analog signal at the input of the transmit path and ends with an analog signal at the output of the receive path.
- An additional analog loopback (ALM1) takes the digital stream at the output of the A/D converter and feeds it back to the D/A converter. (See Figure 24.) The signal path starts with the analog signal at the input of the transmit path and ends with an analog signal at the output of the receive path. This loopback option allows testing of the analog signal processing circuitry of the ProSLIC completely independently of any activity in the DSP.
- The full digital loopback tests almost all the circuitry of both the transmit and receive paths. The analog signal at the output of the receive path is fed back to the input of the transmit path by way of the hybrid filter path. (See Figure 24.) The signal path starts with PCM data input to the receive path and ends with PCM data at the output of the transmit path.
- An additional digital loopback (DLM) takes the digital stream at the input of the D/A converter in the receive path and feeds it back to the transmit A/D digital filter. The signal path starts with PCM data input to the receive path and ends with PCM data at the output of the transmit path. This loopback option allows testing of the ProSLIC digital signal processing circuitry completely independently of any analog signal processing activity.

## 2.6. Two-Wire Impedance Matching

The ProSLIC provides on-chip programmable two-wire impedance settings to meet a wide variety of worldwide two-wire return loss requirements. The two-wire impedance is programmed by loading one of the eight available impedance values into the TISS[2:0] bits of the Two-Wire Impedance Synthesis Control register (direct Register 10). If direct Register 10 is not user-defined, the default setting of  $600 \Omega$  will be loaded into the TISS register.

Real and complex two-wire impedances are realized by internal feedback of a programmable amplifier (RAC), a switched capacitor network (XAC), and a transconductance amplifier ( $G_m$ ) (See Figure 24.) RAC creates the real portion, and XAC creates the imaginary portion of the ac impedance.  $G_m$  then creates a current that models the desired impedance value to the subscriber loop. The differential ac current is fed to the

subscriber loop via the ITIPP and IRINGP pins through an off-chip current buffer ( $I_{BUF}$ ), which is implemented using transistors Q1 and Q2 (see Figure on page 22).  $G_m$  is referenced to an off-chip resistor ( $R_{15}$ ).

The ProSLIC also provides a means of compensating for degraded subscriber loop conditions involving excessive line capacitance (leakage). The CLC[1:0] bits of direct Register 10 increase the ac signal magnitude to compensate for the additional loss at the high end of the audio frequency range. The default setting of CLC[2:0] assumes no line capacitance.

When  $600 + 1 \mu\text{F}$  or  $900 + 2.16 \mu\text{F}$  impedances are selected, an internal reference resistor is removed from the impedance synthesis circuit to accommodate an external resistor,  $R_{ZREF}$ , inserted into the application circuit as shown in Figure 25.

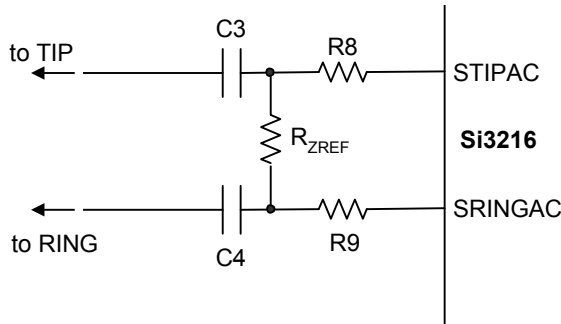

For  $600 + 1 \mu\text{F}$ ,  $R_{ZREF} = 12 \text{ k}\Omega$  and  $C3, C4 = 100 \text{ nF}$   
 For  $900 + 2.16 \mu\text{F}$ ,  $R_{ZREF} = 18 \text{ k}\Omega$  and  $C3, C4 = 220 \text{ nF}$

**Figure 25.  $R_{ZREF}$  External Resistor Placement**

## 2.7. Clock Generation

The ProSLIC generates the necessary internal clock frequencies from the PCLK input. PCLK must be synchronous to the 8 kHz FSYNC clock and run at one of the following rates: 256 kHz, 512 kHz, 768 kHz, 1.024 MHz, 1.536 MHz, 2.048 MHz, 4.096 MHz, or 8.192 MHz. The ratio of the PCLK rate to the FSYNC rate is determined via a counter clocked by PCLK. The three-bit ratio information is automatically transferred into an internal register, PLL\_MULT, following a reset of the ProSLIC. The internal PLL\_MULT register is used to control the internal PLL, which multiplies PCLK as needed to generate the 16.384 MHz rate needed to run the internal filters and other circuitry.

The PLL clock synthesizer settles very quickly following powerup. However, the settling time depends on the PCLK frequency and it can be approximately predicted by the following equation:

$$T_{SETTLE} = \frac{64}{F_{PCLK}}$$

## 2.8. Interrupt Logic

The ProSLIC is capable of generating interrupts for the following events:

- Loop current/ring ground detected
- Ring trip detected
- Power alarm
- Active timer 1 expired
- Inactive timer 1 expired
- Active timer 2 expired
- Inactive timer 2 expired
- Ringing active timer expired
- Ringing inactive timer expired
- Indirect register access complete

The interface to the interrupt logic consists of six registers. Three interrupt status registers contain 1 bit for each of the above interrupt functions. These bits are set when an interrupt is pending for the associated resource. Three interrupt enable registers also contain 1 bit for each interrupt function. In the case of the interrupt enable registers, the bits are active high. Refer to the appropriate functional description section for operational details of the interrupt functions.

When a resource reaches an interrupt condition, it signals an interrupt to the interrupt control block. The interrupt control block then sets the associated bit in the interrupt status register if the enable bit for that interrupt is set. The INT pin is an open-drain output and a NOR of the bits of the interrupt status registers. Therefore, if a bit in the interrupt status registers is asserted, IRQ asserts low. Upon receiving the interrupt, the interrupt handler should read interrupt status registers to determine which resource is requesting service. To clear a pending interrupt, write the desired bit in the appropriate interrupt status register to 1. Writing a 0 has no effect. This provides a mechanism for clearing individual bits when multiple interrupts occur simultaneously. While the interrupt status registers are non-zero, the INT pin will remain asserted.

## 2.9. Serial Peripheral Interface

The control interface to the ProSLIC is a 4-wire interface modeled after commonly-available microcontroller and serial peripheral devices. The interface consists of a clock (SCLK), chip select ( $\overline{CS}$ ), serial data input (SDI), and serial data output (SDO). Data is transferred a byte at a time with each register access consisting of a pair of byte transfers. Figures 26 and 27 illustrate read and write operation in the SPI bus.

The first byte of the pair is the command/address byte. The MSB of this byte indicates a register read when 1 and a register write when 0. The remaining seven bits of

the command/address byte indicate the address of the register to be accessed. The second byte of the pair is the data byte. During a read operation, the SDO becomes active, and the 8-bit contents of the register are driven out MSB first. The SDO will be high impedance on either the falling edge of SCLK following the LSB or the rising edge of  $\overline{CS}$ , whichever comes first. SDI is a “don’t care” during the data portion of read operations. During write operations, data is driven into the ProSLIC via the SDI pin MSB first. The SDO pin remains high-impedance during write operations. Data always transitions with the falling edge of the clock and is latched on the rising edge. The clock should return to a logic high when no transfer is in progress.

There are a number of variations of usage on this four-wire interface:

- Continuous clocking.** During continuous clocking, the data transfers are controlled by the assertion of the  $\overline{CS}$  pin.  $\overline{CS}$  must assert before the falling edge of SCLK on which the first bit of data is expected during a read cycle and must remain low for the duration of

the 8 bit transfer (command/address or data).

- SDI/SDO wired operation.** Independent of the clocking options described, SDI and SDO can be treated as two separate lines or wired together if the master is capable of tristating its output during the data byte transfer of a read operation.
- Daisy chain mode.** This mode allows communication with banks of up to eight ProSLIC devices using one chip select signal. When the SPIDC bit in the SPI Mode Select register is set, data transfer mode changes to a 3-byte operation: a chip select byte, an address/control byte, and a data byte. Using the circuit shown in Figure 28, a single device may select from the bank of devices by setting the appropriate chip select bit to “1”. Each device uses the LSB of the chip select byte, shifts the data right by one bit, and passes the chip select byte using the SDITHRU pin to the next device in the chain. Address/control and data bytes are unaltered.

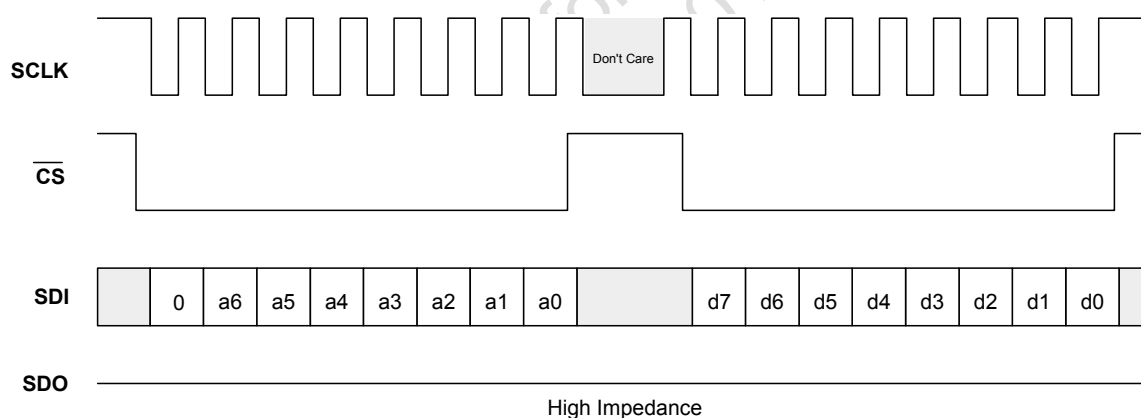

Figure 26. Serial Write 8-Bit Mode

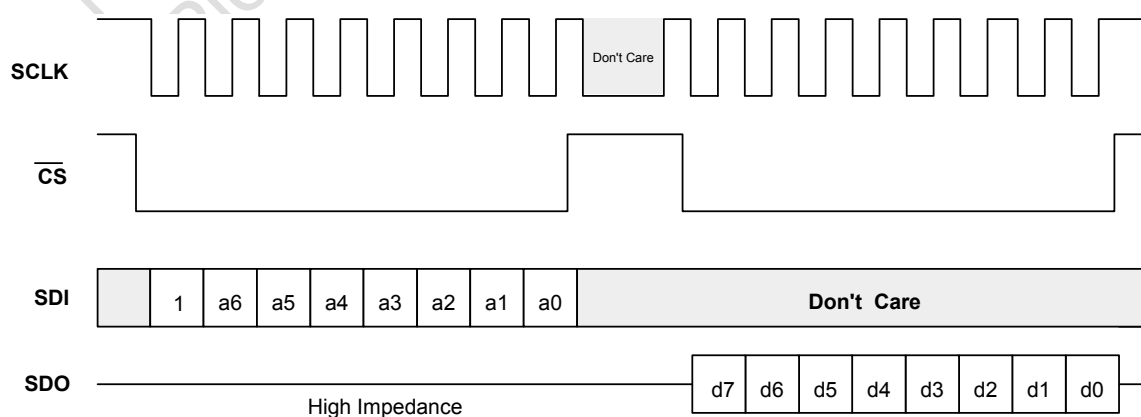
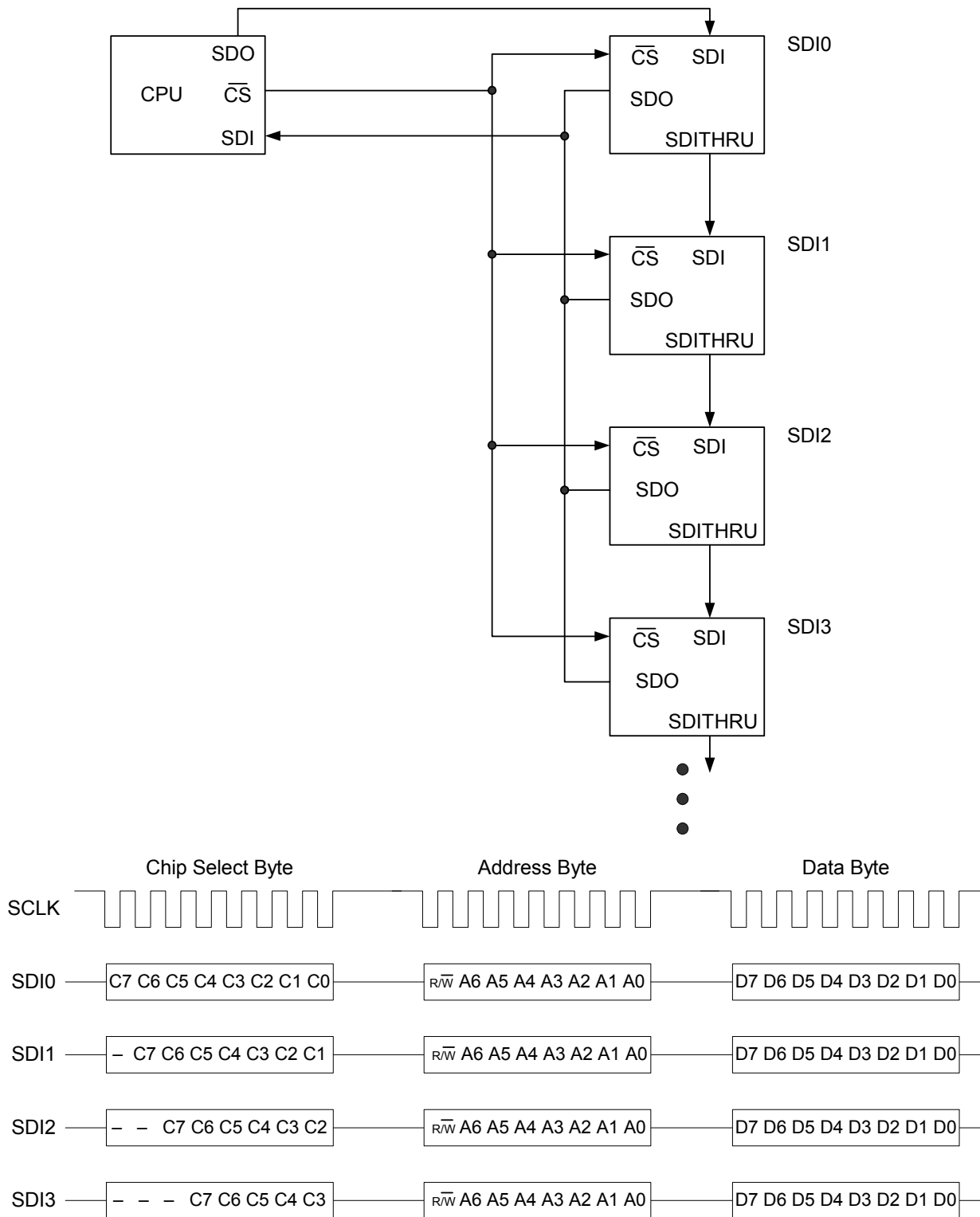

Figure 27. Serial Read 8-Bit Mode



Note: During chip select byte, SDITHRU = SDI delayed by one SCLK. Each device daisy-chained looks at the LSB of the chip select byte for its chip select.

**Figure 28. SPI Daisy Chain Mode**



## 2.10. PCM Interface

The ProSLIC contains a flexible programmable interface for the transmission and reception of digital PCM samples. PCM data transfer is controlled via the PCLK and FSYNC inputs as well as the PCM Mode Select (direct Register 1), PCM Transmit Start Count (direct registers 2 and 3), and PCM Receive Start Count (direct registers 4 and 5) registers. The interface can be configured to support from 2 to 64 16-bit timeslots in each frame. This corresponds to PCLK frequencies of 256 kHz to 8.192 MHz in power-of-2 increments. (768 kHz and 1.536 MHz are also available.) Timeslots for data transmission and reception are independently configured using the TXS and RXS registers. For the Si3216 in wideband mode (WBE = 1, PCMF = 11, and PCMT = 1), TXS and RXS set the correct starting point of the data for the first timeslot within the 8 kHz frame, and the second timeslot is set to follow 62.5  $\mu$ s later.

Figure 29 illustrates the use of the PCM in wideband mode. DTX data is high-impedance except for the duration of the 16-bit PCM transmit. DTX returns to high-impedance either on the negative edge of PCLK during the LSB or on the positive edge of PCLK following the LSB. This is based on the setting of the TRI bit of the PCM Mode Select register. Tristating on the negative edge allows the transmission of data by multiple sources in adjacent timeslots without the risk of driver contention. GCI timing is also supported in which the duration of a data bit is two PCLK cycles. This mode is also activated via the PCM Mode Select register. Setting the TXS or RXS register greater than the number of PCLK cycles in a sample period stops data transmission because TXS or RXS never equals the PCLK count.

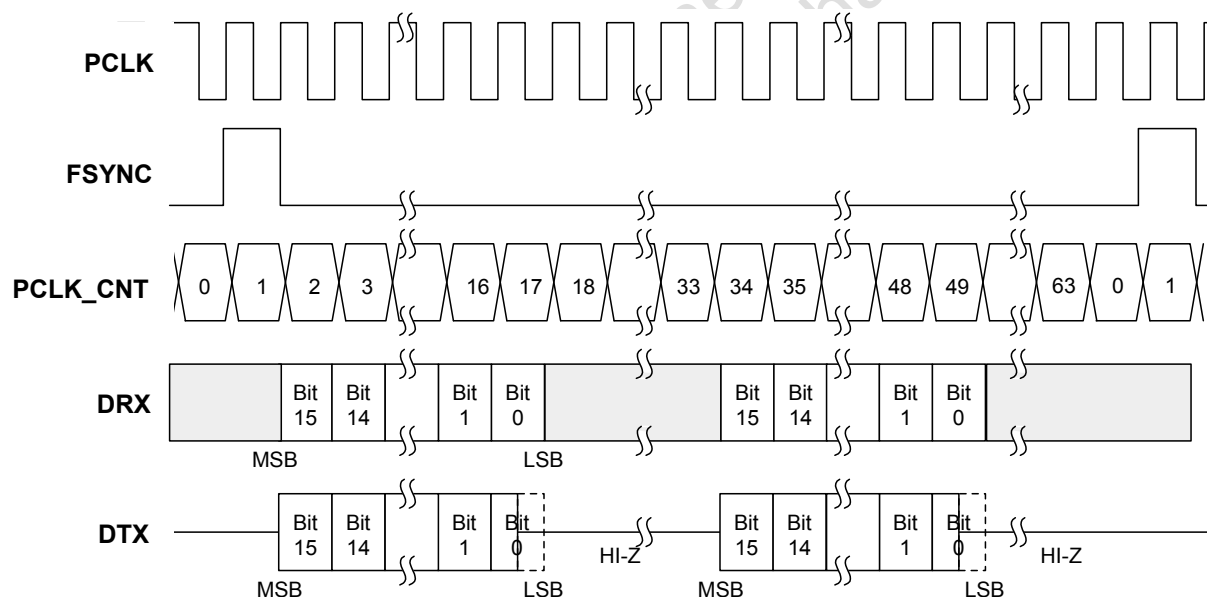

Figure 29. Wideband PCM Operation Example, Short FSYNC, PCLK = 512 kHz (TXS/RXS = 1)

**Table 32.  $\mu$ -Law Encode-Decode Characteristics<sup>1,2</sup>**

Segment Number	#Intervals X Interval Size	Value at Segment Endpoints	Digital Code	Decode Level
8	16 X 256	8159	10000000 <sub>b</sub>	8031
		. . . 4319 4063	10001111 <sub>b</sub>	4191
7	16 X 128	. . . 2143 2015	10011111 <sub>b</sub>	2079
		. . . 1055 991	10101111 <sub>b</sub>	1023
6	16 X 64	. . . 511 479	10111111 <sub>b</sub>	495
		. . . 239 223	11001111 <sub>b</sub>	231
5	16 X 32	. . . 103 95	11011111 <sub>b</sub>	99
		. . . 35 31	11101111 <sub>b</sub>	33
4	16 X 16	. . . 3 1	11111110 <sub>b</sub>	2
		. . . 0	11111111 <sub>b</sub>	0
3	16 X 8	<hr style="width: 100px; margin: 0 auto;"/>		
		1 X 1		

**Notes:**

1. Characteristics are symmetrical about analog zero with sign bit = 0 for negative analog values.
2. Digital code includes inversion of all magnitude bits.

Table 33. A-Law Encode-Decode Characteristics<sup>1,2</sup>

Segment Number	#intervals X interval size	Value at segment endpoints	Digital Code	Decode Level
7	16 X 128	4096 3968 . . 2176 2048	10101010 <sub>b</sub>    10100101 <sub>b</sub>	4032    2112
6	16 X 64	. . . 1088 1024	   10110101 <sub>b</sub>	   1056
5	16 X 32	. . . 544 512	   10000101 <sub>b</sub>	   528
4	16 X 16	. . 272 256	  10010101 <sub>b</sub>	  264
3	16 X 8	. . 136 128	  11100101 <sub>b</sub>	  132
2	16 X 4	. . . 68 64	   11110101 <sub>b</sub>	   66
1	32 X 2	. . . 2 0	   11010101 <sub>b</sub>	   1

**Notes:**

- Characteristics are symmetrical about analog zero with sign bit = 0 for negative values.
- Digital code includes inversion of all even numbered bits.

## 3. Control Registers

**Note:** Any register not listed here is reserved and must not be written.

**Table 34. Direct Register Summary**

Register	Name	Bit 7	Bit 6	Bit 5	Bit 4	Bit 3	Bit 2	Bit 1	Bit 0
<b>Setup</b>									
0	SPI Mode Select	SPIDC	SPIM	PNI[1:0]		RNI[3:0]			
1	PCM Mode Select	PN12	WBE	PCME	PCMF[1:0]		PCMT	GCI	TRI
2	PCM Transmit Start Count—Low Byte	TXS[7:0]							
3	PCM Transmit Start Count—High Byte							TXS[9:8]	
4	PCM Receive Start Count—Low Byte	RXS[7:0]							
5	PCM Receive Start Count—High Byte							RXS[9:8]	
6	Part Number Identification	PNI[2:0]							
<b>Audio</b>									
8	Audio Path Loopback Control						ALM2	DLM	ALM1
9	Audio Gain Control	RXHP	TXHP	TXM	RXM	ATX[1:0]		ARX[1:0]	
10	Two-Wire Impedance Synthesis Control			CLC[1:0]		TISE	TISS[2:0]		
11	Hybrid Control		HYBP[2:0]				HYBA[2:0]		
<b>Powerdown</b>									
14	Powerdown Control 1				DCOF	PFR		BIASOF	SLICOF
15	Powerdown Control 2			ADCM	ADCON	DACM	DACON	GMM	GMON
<b>Interrupts</b>									
18	Interrupt Status 1			RGIP	RGAP	O2IP	O2AP	O1IP	O1AP
19	Interrupt Status 2	Q6AP	Q5AP	Q4AP	Q3AP	Q2AP	Q1AP	LCIP	RTIP
20	Interrupt Status 3							INDP	
21	Interrupt Enable 1			RGIE	RGAE	O2IE	O2AE	O1IE	O1AE
22	Interrupt Enable 2	Q6AE	Q5AE	Q4AE	Q3AE	Q2AE	Q1AE	LCIE	RTIE
23	Interrupt Enable 3							INDE	
<b>Indirect Register Access</b>									
28	Indirect Data Access—Low Byte	IDA[7:0]							
29	Indirect Data Access—High Byte	IDA[15:8]							
30	Indirect Address	IAA[7:0]							

Table 34. Direct Register Summary (Continued)

Register	Name	Bit 7	Bit 6	Bit 5	Bit 4	Bit 3	Bit 2	Bit 1	Bit 0
31	Indirect Address Status								IAS
<b>Oscillators</b>									
32	Oscillator 1 Control	OSS1	REL	OZ1	O1TAE	O1TIE	O1E	O1SO[1:0]	
33	Oscillator 2 Control	OSS2		OZ2	O2TAE	O2TIE	O2E	O2SO[1:0]	
34	Ringling Oscillator Control	RSS		RDAC	RTAE	RTIE	ROE	RVO	TSWS
36	Oscillator 1 Active Timer—Low Byte	OAT1[7:0]							
37	Oscillator 1 Active Timer—High Byte	OAT1[15:8]							
38	Oscillator 1 Inactive Timer—Low Byte	OIT1[7:0]							
39	Oscillator 1 Inactive Timer—High Byte	OIT1[15:8]							
40	Oscillator 2 Active Timer—Low Byte	OAT2[7:0]							
41	Oscillator 2 Active Timer—High Byte	OAT2[15:8]							
42	Oscillator 2 Inactive Timer—Low Byte	OIT2[7:0]							
43	Oscillator 2 Inactive Timer—High Byte	OIT2[15:8]							
48	Ringling Oscillator Active Timer—Low Byte	RAT[7:0]							
49	Ringling Oscillator Active Timer—High Byte	RAT[15:8]							
50	Ringling Oscillator Inactive Timer—Low Byte	RIT[7:0]							
51	Ringling Oscillator Inactive Timer—High Byte	RIT[15:8]							
52	FSK Data								FSKDAT
<b>SLIC</b>									
63	Loop Closure Debounce Interval	LCD[7:0]							
64	Linefeed Control		LFS[2:0]				LF[2:0]		
65	External Bipolar Transistor Control		SQH	CBY	ETBE	ETBO[1:0]		ETBA[1:0]	
66	Battery Feed Control				VOV	FVBAT			TRACK
67	Automatic/Manual Control		MNCM	MNDIF	SPDS		AORD	AOLD	AOPN

**Table 34. Direct Register Summary (Continued)**

Register	Name	Bit 7	Bit 6	Bit 5	Bit 4	Bit 3	Bit 2	Bit 1	Bit 0
68	Loop Closure/Ring Trip Detect Status						DBIRAW	RTP	LCR
69	Loop Closure Debounce Interval	LCDI[6:0]							
70	Ring Trip Detect Debounce Interval	RTDI[6:0]							
71	Loop Current Limit						ILIM[2:0]		
72	On-Hook Line Voltage		VSGN	VOC[5:0]					
73	Common Mode Voltage	VCM[5:0]							
74	High Battery Voltage	VBATH[5:0]							
75	Low Battery Voltage	VBATL[5:0]							
76	Power Monitor Pointer						PWRMP[2:0]		
77	Line Power Output Monitor	PWROM[7:0]							
78	Loop Voltage Sense		LVSP	LVS[5:0]					
79	Loop Current Sense		LCSP	LCS[5:0]					
80	TIP Voltage Sense	VTIP[7:0]							
81	RING Voltage Sense	VRING[7:0]							
82	Battery Voltage Sense 1	VBATS1[7:0]							
83	Battery Voltage Sense 2	VBATS2[7:0]							
84	Transistor 1 Current Sense	IQ1[7:0]							
85	Transistor 2 Current Sense	IQ2[7:0]							
86	Transistor 3 Current Sense	IQ3[7:0]							
87	Transistor 4 Current Sense	IQ4[7:0]							
88	Transistor 5 Current Sense	IQ5[7:0]							
89	Transistor 6 Current Sense	IQ6[7:0]							
92	DC-DC Converter PWM Period	DCN[7:0]							
93	DC-DC Converter Switching Delay	DCCAL		DCPOL	DCTOF[4:0]				
94	DC-DC Converter PWM Pulse Width	DCPW[7:0]							
95	Reserved								

Table 34. Direct Register Summary (Continued)

Register	Name	Bit 7	Bit 6	Bit 5	Bit 4	Bit 3	Bit 2	Bit 1	Bit 0
96	Calibration Control/ Status Register 1		CAL	CALSP	CALR	CALT	CALD	CALC	CALIL
97	Calibration Control/ Status Register 2				CALM1	CALM2	CALDAC	CALADC	
98	RING Gain Mismatch Calibration Result				CALGMR[4:0]				
99	TIP Gain Mismatch Calibration Result				CALGMT[4:0]				
100	Differential Loop Current Gain Calibration Result				CALGD[4:0]				
101	Common Mode Loop Current Gain Calibration Result				CALGC[4:0]				
102	Current Limit Calibration Result					CALGIL[3:0]			
103	Monitor ADC Offset Calibration Result	CALMG1[3:0]				CALMG2[3:0]			
104	Analog DAC/ADC Offset					DACP	DACN	ADCP	ADCN
105	DAC Offset Calibration Result	DACOF[7:0]							
107	DC Peak Current Moni- tor Calibration Result					CMDCPK[3:0]			
108	Enhancement Enable	ILIMEN	FSKEN	DCSU			LCVE	DCFIL	HYSTEN

## Register 0. SPI Mode Select

Bit	D7	D6	D5	D4	D3	D2	D1	D0
<b>Name</b>	SPIDC	SPIM	PNI[1:0]		RNI[3:0]			
<b>Type</b>	R/W	R/W	R		R			

Reset settings = 00xx\_xxxx

Bit	Name	Function
7	SPIDC	<b>SPI Daisy Chain Mode Enable.</b> 0 = Disable SPI daisy chain mode. 1 = Enable SPI daisy chain mode.
6	SPIM	<b>SPI Mode.</b> 0 = Causes SDO to tri-state on rising edge of SCLK of LSB. 1 = Normal operation; SDO tri-states on rising edge of CS.
5:4	PNI[1:0]	<b>Part Number Identification.</b> <b>Note:</b> PNI[2:0] can be read in direct register 6. 00 = Si3216 01 = Reserved 10 = Reserved 11 = Si3216M
3:0	RNI[3:0]	<b>Revision Number Identification.</b> 0001 = Revision A, 0010 = Revision B, 0011 = Revision C, etc.



**Register 1. PCM Mode Select**

Bit	D7	D6	D5	D4	D3	D2	D1	D0
Name	PNI2	WBE	PCME	PCMF[1:0]		PCMT	GCI	TRI
Type	R	R/W	R/W	R/W		R/W	R/W	R/W

Reset settings = 1000\_1000

Bit	Name	Function
7	PNI2	<b>Part Number Identification 2.</b> <b>Note:</b> PNI[2:0] can be read in direct Register 6. 0 = Si3210, Si3211 family. 1 = Si3216 family.
6	WBE	<b>Wideband Enable.</b> 0 = Narrowband (200 Hz–3.4 kHz) audio filtering at 8 kHz sample rate. 1 = Wideband (50 Hz–7 kHz) audio filtering at 16 kHz sample rate when PCMF = 11 and PCMT = 1.
5	PCME	<b>PCM Enable.</b> 0 = Disable PCM transfers. 1 = Enable PCM transfers.
4:3	PCMF[1:0]	<b>PCM Format.</b> 00 = A-Law 01 = $\mu$ -Law 10 = Reserved 11 = Linear
2	PCMT	<b>PCM Transfer Size.</b> 0 = 8-bit transfer. 1 = 16-bit transfer.
1	GCI	<b>GCI Clock Format.</b> 0 = 1 PCLK per data bit. 1 = 2 PCLKs per data bit.
0	TRI	<b>Tri-state Bit 0.</b> 0 = Tri-state bit 0 on positive edge of PCLK. 1 = Tri-state bit 0 on negative edge of PCLK.

## Register 2. PCM Transmit Start Count—Low Byte

Bit	D7	D6	D5	D4	D3	D2	D1	D0
Name	TXS[7:0]							
Type	R/W							

Reset settings = 0000\_0000

Bit	Name	Function
7:0	TXS[7:0]	<b>PCM Transmit Start Count.</b> PCM transmit start count equals the number of PCLKs following FSYNC before data transmission begins. See Figure 29 on page 49.

## Register 3. PCM Transmit Start Count—High Byte

Bit	D7	D6	D5	D4	D3	D2	D1	D0
Name							TXS[9:8]	
Type	R/W							

Reset settings = 0000\_0000

Bit	Name	Function
7:2	Reserved	Read returns zero.
1:0	TXS[9:8]	<b>PCM Transmit Start Count.</b> PCM transmit start count equals the number of PCLKs following FSYNC before data transmission begins. See Figure 29 on page 49.

## Register 4. PCM Receive Start Count—Low Byte

Bit	D7	D6	D5	D4	D3	D2	D1	D0
Name	RXS[7:0]							
Type	R/W							

Reset settings = 0000\_0000

Bit	Name	Function
7:0	RXS[7:0]	<b>PCM Receive Start Count.</b> PCM receive start count equals the number of PCLKs following FSYNC before data reception begins. See Figure 29 on page 49.

**Register 5. PCM Receive Start Count—High Byte**

Bit	D7	D6	D5	D4	D3	D2	D1	D0
<b>Name</b>							RXS[9:8]	
<b>Type</b>	R/W							

Reset settings = 0000\_0000

Bit	Name	Function
7:2	Reserved	Read returns zero.
1:0	RXS[9:8]	<b>PCM Receive Start Count.</b> PCM receive start count equals the number of PCLKs following FSYNC before data reception begins. See Figure 29 on page 49.

**Register 6. Part Number Identification**

Bit	D7	D6	D5	D4	D3	D2	D1	D0
<b>Name</b>	PNI[2:0]							
<b>Type</b>	R							

Reset settings = 0xx0\_0000

Bit	Name	Function
7:5	PNI[2:0]	<b>Part Number Identification.</b> <b>Note:</b> PNI[2] can be read in direct Register 1. PNI[1:0] can be read in direct Register 0. 000 = Reserved                      100 = Si3216 001 = Reserved                      101 = Reserved 010 = Reserved                      110 = Reserved 011 = Reserved                      111 = Si3216M
4:0	Reserved	Read returns zero.

## Register 8. Audio Path Loopback Control

Bit	D7	D6	D5	D4	D3	D2	D1	D0
Name						ALM2	DLM	ALM1
Type						R/W	R/W	R/W

Reset settings = 0000\_0010

Bit	Name	Function
7:3	Reserved	Read returns zero.
2	ALM2	<b>Analog Loopback Mode 2. (See Figure 24 on page 44.)</b> 0 = Full analog loopback mode disabled. 1 = Full analog loopback mode enabled.
1	DLM	<b>Digital Loopback Mode. (See Figure 24 on page 44.)</b> 0 = Digital loopback disabled. 1 = Digital loopback enabled.
0	ALM1	<b>Analog Loopback Mode 1. (See Figure 24 on page 44.)</b> 0 = Analog loopback disabled. 1 = Analog loopback enabled.

Not recommended for new designs.  
Please note the Si3216 has been discontinued.

**Register 9. Audio Gain Control**

Bit	D7	D6	D5	D4	D3	D2	D1	D0
<b>Name</b>	RXHP	TXHP	TXM	RXM	ATX[1:0]		ARX[1:0]	
<b>Type</b>	R/W	R/W	R/W	R/W	R/W		R/W	

Reset settings = 0000\_0000

Bit	Name	Function
7	RXHP	<b>Receive Path High Pass Filter Disable.</b> 0 = HPF enabled in receive path, RHDF. 1 = HPF bypassed in receive path, RHDF.
6	TXHP	<b>Transmit Path High Pass Filter Disable.</b> 0 = HPF enabled in transmit path, THPF. 1 = HPF bypassed in transmit path, THPF.
5	TXM	<b>Transmit Path Mute.</b> Refer to position of digital mute in Figure 24 on page 44. 0 = Transmit signal passed. 1 = Transmit signal muted.
4	RXM	<b>Receive Path Mute.</b> Refer to position of digital mute in Figure 24 on page 44. 0 = Receive signal passed. 1 = Receive signal muted.
3:2	ATX[1:0]	<b>Analog Transmit Path Gain.</b> 00 = 0 dB 01 = -3.5 dB 10 = 3.5 dB 11 = ATX gain = 0 dB; analog transmit path muted.
1:0	ARX[1:0]	<b>Analog Receive Path Gain.</b> 00 = 0 dB 01 = -3.5 dB 10 = 3.5 dB 11 = Analog receive path muted.

## Register 10. Two-Wire Impedance Synthesis Control

Bit	D7	D6	D5	D4	D3	D2	D1	D0
Name			CLC[1:0]		TISE	TISS[2:0]		
Type			R/W		R/W	R/W		

Reset settings = 0000\_1000

Bit	Name	Function
7:6	Reserved	Read returns zero.
5:4	CLC[1:0]	<b>Line Capacitance Compensation.</b> 00 = Off 01 = 4.7 nF 10 = 10 nF 11 = Reserved
3	TISE	<b>Two-Wire Impedance Synthesis Enable.</b> 0 = Two-wire impedance synthesis disabled. 1 = Two-wire impedance synthesis enabled.
2:0	TISS[2:0]	<b>Two-Wire Impedance Synthesis Selection.</b> 000 = 600 $\Omega$ 001 = 900 $\Omega$ 010 = Japan (600 $\Omega$ + 1 $\mu$ F); requires external resistor $R_{ZREF} = 12$ k $\Omega$ and C3, C4 = 100 nF. 011 = 900 $\Omega$ + 2.16 $\mu$ F; requires external resistor $R_{ZREF} = 18$ k $\Omega$ and C3, C4 = 220 nF. 100 = CTR21 (270 $\Omega$ + 750 $\Omega$    150 nF). 101 = Australia/New Zealand #1 (220 $\Omega$ + 820 $\Omega$    120 nF). 110 = Slovakia/Slovenia/South Africa (220 $\Omega$ + 820 $\Omega$    115 nF). 111 = China (200 $\Omega$ + 680 $\Omega$    100 nF).

## Register 11. Hybrid Control

Bit	D7	D6	D5	D4	D3	D2	D1	D0
Name		HYBP[2:0]				HYBA[2:0]		
Type	R/W				R/W			

Reset settings = 0011\_0011

Bit	Name	Function
7	Reserved	Read returns zero.
6:4	HYBP[2:0]	<b>Pulse Metering Hybrid Adjustment.</b> 000 = 4.08 dB 001 = 2.5 dB 010 = 1.16 dB 011 = 0 dB 100 = -1.02 dB 101 = -1.94 dB 110 = -2.77 dB 111 = Off
3	Reserved	Read returns zero.
2:0	HYBA[2:0]	<b>Audio Hybrid Adjustment.</b> 000 = 4.08 dB 001 = 2.5 dB 010 = 1.16 dB 011 = 0 dB 100 = -1.02 dB 101 = -1.94 dB 110 = -2.77 dB 111 = Off

## Register 14. Powerdown Control 1

Bit	D7	D6	D5	D4	D3	D2	D1	D0
Name				DCOF	PFR		BIASOF	SLICOF
Type				R/W	R/W			R/W

Reset settings = 0001\_0000

Bit	Name	Function
7:5	Reserved	Read returns zero.
4	DCOF	<b>DC-DC Converter Power-Off Control.</b> 0 = Automatic power control. 1 = Override automatic control and force dc-dc circuitry off.
3	PFR	<b>PLL Free-Run Control.</b> 0 = Automatic free-run control. 1 = Override automatic control and force PLL into free-run state.
2	Reserved	Read returns zero.
1	BIASOF	<b>DC Bias Power-Off Control.</b> 0 = Automatic power control. 1 = Override automatic control and force dc bias circuitry off.
0	SLICOF	<b>SLIC Power-Off Control.</b> 0 = Automatic power control. 1 = Override automatic control and force SLIC circuitry off.



**Register 15. Powerdown Control 2**

Bit	D7	D6	D5	D4	D3	D2	D1	D0
Name			ADCM	ADCON	DACM	DACON	GMM	GMON
Type			R/W	R/W	R/W	R/W	R/W	R/W

Reset settings = 0000\_0000

Bit	Name	Function
7:6	Reserved	Read returns zero.
5	ADCM	<b>Analog to Digital Converter Manual/Automatic Power Control.</b> 0 = Automatic power control. 1 = Manual power control; ADCON controls on/off state.
4	ADCON	<b>Analog to Digital Converter On/Off Power Control.</b> When ADCM = 1: 0 = Analog to digital converter powered off. 1 = Analog to digital converter powered on. ADCON has no effect when ADCM = 0.
3	DACM	<b>Digital to Analog Converter Manual/Automatic Power Control.</b> 0 = Automatic power control. 1 = Manual power control; DACON controls on/off state.
2	DACON	<b>Digital to Analog Converter On/Off Power Control.</b> When DACM = 1: 0 = Digital to analog converter powered off. 1 = Digital to analog converter powered on. DACON has no effect when DACM = 0.
1	GMM	<b>Transconductance Amplifier Manual/Automatic Power Control.</b> 0 = Automatic power control. 1 = Manual power control; GMON controls on/off state.
0	GMON	<b>Transconductance Amplifier On/Off Power Control.</b> When GMM = 1: 0 = Analog to digital converter powered off. 1 = Analog to digital converter powered on. GMON has no effect when GMM = 0.

## Register 18. Interrupt Status 1

Bit	D7	D6	D5	D4	D3	D2	D1	D0
Name			RGIP	RGAP	O2IP	O2AP	O1IP	O1AP
Type			R/W	R/W	R/W	R/W	R/W	R/W

Reset settings = 0000\_0000

Bit	Name	Function
7:6	Reserved	Read returns zero.
5	RGIP	<b>Ringing Inactive Timer Interrupt Pending.</b> Writing 1 to this bit clears a pending interrupt. 0 = No interrupt pending. 1 = Interrupt pending.
4	RGAP	<b>Ringing Active Timer Interrupt Pending.</b> Writing 1 to this bit clears a pending interrupt. 0 = No interrupt pending. 1 = Interrupt pending.
3	O2IP	<b>Oscillator 2 Inactive Timer Interrupt Pending.</b> Writing 1 to this bit clears a pending interrupt. 0 = No interrupt pending. 1 = Interrupt pending.
2	O2AP	<b>Oscillator 2 Active Timer Interrupt Pending.</b> Writing 1 to this bit clears a pending interrupt. 0 = No interrupt pending. 1 = Interrupt pending.
1	O1IP	<b>Oscillator 1 Inactive Timer Interrupt Pending.</b> Writing 1 to this bit clears a pending interrupt. 0 = No interrupt pending. 1 = Interrupt pending.
0	O1AP	<b>Oscillator 1 Active Timer Interrupt Pending.</b> Writing 1 to this bit clears a pending interrupt. 0 = No interrupt pending. 1 = Interrupt pending.

**Register 19. Interrupt Status 2**

Bit	D7	D6	D5	D4	D3	D2	D1	D0
<b>Name</b>	Q6AP	Q5AP	Q4AP	Q3AP	Q2AP	Q1AP	LCIP	RTIP
<b>Type</b>	R/W	R/W	R/W	R/W	R/W	R/W	R/W	R/W

Reset settings = 0000\_0000

Bit	Name	Function
7	Q6AP	<b>Power Alarm Q6 Interrupt Pending.</b> Writing 1 to this bit clears a pending interrupt. 0 = No interrupt pending. 1 = Interrupt pending.
6	Q5AP	<b>Power Alarm Q5 Interrupt Pending.</b> Writing 1 to this bit clears a pending interrupt. 0 = No interrupt pending. 1 = Interrupt pending.
5	Q4AP	<b>Power Alarm Q4 Interrupt Pending.</b> Writing 1 to this bit clears a pending interrupt. 0 = No interrupt pending. 1 = Interrupt pending.
4	Q3AP	<b>Power Alarm Q3 Interrupt Pending.</b> Writing 1 to this bit clears a pending interrupt. 0 = No interrupt pending. 1 = Interrupt pending.
3	Q2AP	<b>Power Alarm Q2 Interrupt Pending.</b> Writing 1 to this bit clears a pending interrupt. 0 = No interrupt pending. 1 = Interrupt pending.
2	Q1AP	<b>Power Alarm Q1 Interrupt Pending.</b> Writing 1 to this bit clears a pending interrupt. 0 = No interrupt pending. 1 = Interrupt pending.
1	LCIP	<b>Loop Closure Transition Interrupt Pending.</b> Writing 1 to this bit clears a pending interrupt. 0 = No interrupt pending. 1 = Interrupt pending.
0	RTIP	<b>Ring Trip Interrupt Pending.</b> Writing 1 to this bit clears a pending interrupt. 0 = No interrupt pending. 1 = Interrupt pending.

## Register 20. Interrupt Status 3

Bit	D7	D6	D5	D4	D3	D2	D1	D0	
Name							INDP		
Type								R/W	

Reset settings = 0000\_0000

Bit	Name	Function
7:2	Reserved	Read returns zero.
1	INDP	<b>Indirect Register Access Serviced Interrupt.</b> This bit is set once a pending indirect register service request has been completed. Writing 1 to this bit clears a pending interrupt. 0 = No interrupt pending. 1 = Interrupt pending.
0	Reserved	Read returns zero.

Not recommended for new designs.  
Please note the Si3201 has been discontinued.

**Register 21. Interrupt Enable 1**

Bit	D7	D6	D5	D4	D3	D2	D1	D0
Name			RGIE	RGAE	O2IE	O2AE	O1IE	O1AE
Type			R/W	R/W	R/W	R/W	R/W	R/W

Reset settings = 0000\_0000

Bit	Name	Function
7:6	Reserved	Read/write bit with no function.
5	RGIE	<b>Ringling Inactive Timer Interrupt Enable.</b> 0 = Interrupt masked. 1 = Interrupt enabled.
4	RGAE	<b>Ringling Active Timer Interrupt Enable.</b> 0 = Interrupt masked. 1 = Interrupt enabled.
3	O2IE	<b>Oscillator 2 Inactive Timer Interrupt Enable.</b> 0 = Interrupt masked. 1 = Interrupt enabled.
2	O2AE	<b>Oscillator 2 Active Timer Interrupt Enable.</b> 0 = Interrupt masked. 1 = Interrupt enabled.
1	O1IE	<b>Oscillator 1 Inactive Timer Interrupt Enable.</b> 0 = Interrupt masked. 1 = Interrupt enabled.
0	O1AE	<b>Oscillator 1 Active Timer Interrupt Enable.</b> 0 = Interrupt masked. 1 = Interrupt enabled.

## Register 22. Interrupt Enable 2

Bit	D7	D6	D5	D4	D3	D2	D1	D0
Name	Q6AE	Q5AE	Q4AE	Q3AE	Q2AE	Q1AE	LCIE	RTIE
Type	R/W	R/W	R/W	R/W	R/W	R/W	R/W	R/W

Reset settings = 0000\_0000

Bit	Name	Function
7	Q6AE	<b>Power Alarm Q6 Interrupt Enable.</b> 0 = Interrupt masked. 1 = Interrupt enabled.
6	Q5AE	<b>Power Alarm Q5 Interrupt Enable.</b> 0 = Interrupt masked. 1 = Interrupt enabled.
5	Q4AE	<b>Power Alarm Q4 Interrupt Enable.</b> 0 = Interrupt masked. 1 = Interrupt enabled.
4	Q3AE	<b>Power Alarm Q3 Interrupt Enable.</b> 0 = Interrupt masked. 1 = Interrupt enabled.
3	Q2AE	<b>Power Alarm Q2 Interrupt Enable.</b> 0 = Interrupt masked. 1 = Interrupt enabled.
2	Q1AE	<b>Power Alarm Q1 Interrupt Enable.</b> 0 = Interrupt masked. 1 = Interrupt enabled.
1	LCIE	<b>Loop Closure Transition Interrupt Enable.</b> 0 = Interrupt masked. 1 = Interrupt enabled.
0	RTIE	<b>Ring Trip Interrupt Enable.</b> 0 = Interrupt masked. 1 = Interrupt enabled.

**Register 23. Interrupt Enable 3**

Bit	D7	D6	D5	D4	D3	D2	D1	D0	
Name							INDE		
Type								R/W	

Reset settings = 0000\_0000

Bit	Name	Function
7:2	Reserved	Read returns zero.
1	INDE	<b>Indirect Register Access Serviced Interrupt Enable.</b> 0 = Interrupt masked. 1 = Interrupt enabled.
0	Reserved	Read/write bit with no function.

Not recommended for new designs.  
Please note the Si3201 has been discontinued.

## Register 28. Indirect Data Access—Low Byte

Bit	D7	D6	D5	D4	D3	D2	D1	D0
Name	IDA[7:0]							
Type	R/W							

Reset settings = 0000\_0000

Bit	Name	Function
7:0	IDA[7:0]	<p><b>Indirect Data Access—Low Byte.</b></p> <p>A write to IDA followed by a write to IAA will place the contents of IDA into an indirect register at the location referenced by IAA at the next indirect register update (16 kHz update rate—a write operation). Writing IAA only will load IDA with the value stored at IAA at the next indirect memory update (a read operation).</p>

## Register 29. Indirect Data Access—High Byte

Bit	D7	D6	D5	D4	D3	D2	D1	D0
Name	IDA[15:8]							
Type	R/W							

Reset settings = 0000\_0000

Bit	Name	Function
7:0	IDA[15:8]	<p><b>Indirect Data Access—High Byte.</b></p> <p>A write to IDA followed by a write to IAA will place the contents of IDA into an indirect register at the location referenced by IAA at the next indirect register update (16 kHz update rate—a write operation). Writing IAA only will load IDA with the value stored at IAA at the next indirect memory update (a read operation).</p>



**Register 30. Indirect Address**

Bit	D7	D6	D5	D4	D3	D2	D1	D0
<b>Name</b>	IAA[7:0]							
<b>Type</b>	R/W							

Reset settings = xxxx\_xxxx

Bit	Name	Function
7:0	IAA[7:0]	<b>Indirect Address Access.</b> A write to IDA followed by a write to IAA will place the contents of IDA into an indirect register at the location referenced by IAA at the next indirect register update (16 kHz update rate—a write operation). Writing IAA only will load IDA with the value stored at IAA at the next indirect memory update (a read operation).

**Register 31. Indirect Address Status**

Bit	D7	D6	D5	D4	D3	D2	D1	D0
<b>Name</b>								IAS
<b>Type</b>	R							

Reset settings = 0000\_0000

Bit	Name	Function
7:1	Reserved	Read returns zero.
0	IAS	<b>Indirect Access Status.</b> 0 = No indirect memory access pending. 1 = Indirect memory access pending.

## Register 32. Oscillator 1 Control

Bit	D7	D6	D5	D4	D3	D2	D1	D0
Name	OSS1	REL	OZ1	O1TAE	O1TIE	O1E	O1SO[1:0]	
Type	R	R/W	R/W	R/W	R/W	R/W	R/W	

Reset settings = 0000\_0000

Bit	Name	Function
7	OSS1	<b>Oscillator 1 Signal Status.</b> 0 = Output signal inactive. 1 = Output signal active.
6	REL	<b>Oscillator 1 Automatic Register Reload.</b> This bit should be set for FSK signaling. 0 = Oscillator 1 will stop signaling after inactive timer expires. 1 = Oscillator 1 will continue to read register parameters and output signals.
5	OZ1	<b>Oscillator 1 Zero Cross Enable.</b> 0 = Signal terminates after active timer expires. 1 = Signal terminates at zero crossing after active timer expires.
4	O1TAE	<b>Oscillator 1 Active Timer Enable.</b> 0 = Disable timer. 1 = Enable timer.
3	O1TIE	<b>Oscillator 1 Inactive Timer Enable.</b> 0 = Disable timer. 1 = Enable timer.
2	O1E	<b>Oscillator 1 Enable.</b> 0 = Disable oscillator. 1 = Enable oscillator.
1:0	O1SO[1:0]	<b>Oscillator 1 Signal Output Routing.</b> 00 = Unassigned path (output not connected). 01 = Assign to transmit path. 10 = Assign to receive path. 11 = Assign to both paths.

**Register 33. Oscillator 2 Control**

Bit	D7	D6	D5	D4	D3	D2	D1	D0
Name	OSS2		OZ2	O2TAE	O2TIE	O2E	O2SO[1:0]	
Type	R		R/W	R/W	R/W	R/W	R/W	

Reset settings = 0000\_0000

Bit	Name	Function
7	OSS2	<b>Oscillator 2 Signal Status.</b> 0 = Output signal inactive. 1 = Output signal active.
6	Reserved	Read returns zero.
5	OZ2	<b>Oscillator 2 Zero Cross Enable.</b> 0 = Signal terminates after active timer expires. 1 = Signal terminates at zero crossing.
4	O2TAE	<b>Oscillator 2 Active Timer Enable.</b> 0 = Disable timer. 1 = Enable timer.
3	O2TIE	<b>Oscillator 2 Inactive Timer Enable.</b> 0 = Disable timer. 1 = Enable timer.
2	O2E	<b>Oscillator 2 Enable.</b> 0 = Disable oscillator. 1 = Enable oscillator.
1:0	O2SO[1:0]	<b>Oscillator 2 Signal Output Routing.</b> 00 = Unassigned path (output not connected). 01 = Assign to transmit path. 10 = Assign to receive path. 11 = Assign to both paths.

## Register 34. Ringing Oscillator Control

Bit	D7	D6	D5	D4	D3	D2	D1	D0
Name	RSS		RDAC	RTAE	RTIE	ROE	RVO	TSWS
Type	R		R	R/W	R/W	R	R/W	R/W

Reset settings = 0000\_0000

Bit	Name	Function
7	RSS	<b>Ringling Signal Status.</b> 0 = Ringing oscillator output signal inactive. 1 = Ringing oscillator output signal active.
6	Reserved	Read returns zero.
5	RDAC	<b>Ringling Signal DAC/Linefeed Cross Indicator.</b> For ringing signal start and stop, output to TIP and RING is suspended to ensure continuity with dc linefeed voltages. RDAC indicates that ringing signal is actually present at TIP and RING. 0 = Ringing signal not present at TIP and RING. 1 = Ringing signal present at TIP and RING.
4	RTAE	<b>Ringling Active Timer Enable.</b> 0 = Disable timer. 1 = Enable timer.
3	RTIE	<b>Ringling Inactive Timer Enable.</b> 0 = Disable timer. 1 = Enable timer.
2	ROE	<b>Ringling Oscillator Enable.</b> 0 = Ringing oscillator disabled. 1 = Ringing oscillator enabled.
1	RVO	<b>Ringling Voltage Offset.</b> 0 = No dc offset added to ringing signal. 1 = DC offset added to ringing signal.
0	TSWS	<b>Trapezoid/Sinusoid Waveshape Select.</b> 0 = Sinusoid. 1 = Trapezoid.

**Register 36. Oscillator 1 Active Timer—Low Byte**

Bit	D7	D6	D5	D4	D3	D2	D1	D0
<b>Name</b>	OAT1[7:0]							
<b>Type</b>	R/W							

Reset settings = 0000\_0000

Bit	Name	Function
7:0	OAT1[7:0]	<b>Oscillator 1 Active Timer.</b> LSB = 125 $\mu$ s

**Register 37. Oscillator 1 Active Timer—High Byte**

Bit	D7	D6	D5	D4	D3	D2	D1	D0
<b>Name</b>	OAT1[15:8]							
<b>Type</b>	R/W							

Reset settings = 0000\_0000

Bit	Name	Function
7:0	OAT1[15:8]	<b>Oscillator 1 Active Timer.</b>

**Register 38. Oscillator 1 Inactive Timer—Low Byte**

Bit	D7	D6	D5	D4	D3	D2	D1	D0
<b>Name</b>	OIT1[7:0]							
<b>Type</b>	R/W							

Reset settings = 0000\_0000

Bit	Name	Function
7:0	OIT1[7:0]	<b>Oscillator 1 Inactive Timer.</b> LSB = 125 $\mu$ s

## Register 39. Oscillator 1 Inactive Timer—High Byte

Bit	D7	D6	D5	D4	D3	D2	D1	D0
Name	OIT1[15:8]							
Type	R/W							

Reset settings = 0000\_0000

Bit	Name	Function
7:0	OIT1[15:8]	Oscillator 1 Inactive Timer.

## Register 40. Oscillator 2 Active Timer—Low Byte

Bit	D7	D6	D5	D4	D3	D2	D1	D0
Name	OAT2[7:0]							
Type	R/W							

Reset settings = 0000\_0000

Bit	Name	Function
7:0	OAT2[7:0]	Oscillator 2 Active Timer. LSB = 125 $\mu$ s

## Register 41. Oscillator 2 Active Timer—High Byte

Bit	D7	D6	D5	D4	D3	D2	D1	D0
Name	OAT2[15:8]							
Type	R/W							

Reset settings = 0000\_0000

Bit	Name	Function
7:0	OAT2[15:8]	Oscillator 2 Active Timer.

**Register 42. Oscillator 2 Inactive Timer—Low Byte**

Bit	D7	D6	D5	D4	D3	D2	D1	D0
<b>Name</b>	OIT2[7:0]							
<b>Type</b>	R/W							

Reset settings = 0000\_0000

Bit	Name	Function
7:0	OIT2[7:0]	<b>Oscillator 2 Inactive Timer.</b> LSB = 125 $\mu$ s

**Register 43. Oscillator 2 Inactive Timer—High Byte**

Bit	D7	D6	D5	D4	D3	D2	D1	D0
<b>Name</b>	OIT2[15:8]							
<b>Type</b>	R/W							

Reset settings = 0000\_0000

Bit	Name	Function
7:0	OIT2[15:8]	<b>Oscillator 2 Inactive Timer.</b>

**Register 48. Ringing Oscillator Active Timer—Low Byte**

Bit	D7	D6	D5	D4	D3	D2	D1	D0
<b>Name</b>	RAT[7:0]							
<b>Type</b>	R/W							

Reset settings = 0000\_0000

Bit	Name	Function
7:0	RAT[7:0]	<b>Ringing Active Timer.</b> LSB = 125 $\mu$ s

## Register 49. Ringing Oscillator Active Timer—High Byte

Bit	D7	D6	D5	D4	D3	D2	D1	D0
Name	RAT[15:8]							
Type	R/W							

Reset settings = 0000\_0000

Bit	Name	Function
7:0	RAT[15:8]	<b>Ringling Active Timer.</b>

## Register 50. Ringing Oscillator Inactive Timer—Low Byte

Bit	D7	D6	D5	D4	D3	D2	D1	D0
Name	RIT[7:0]							
Type	R/W							

Reset settings = 0000\_0000

Bit	Name	Function
7:0	RIT[7:0]	<b>Ringling Inactive Timer.</b> LSB = 125 $\mu$ s

## Register 51. Ringing Oscillator Inactive Timer—High Byte

Bit	D7	D6	D5	D4	D3	D2	D1	D0
Name	RIT[15:8]							
Type	R/W							

Reset settings = 0000\_0000

Bit	Name	Function
7:0	RIT[15:8]	<b>Ringling Inactive Timer.</b>



**Register 52. FSK Data**

Bit	D7	D6	D5	D4	D3	D2	D1	D0
Name								FSKDAT
Type								R/W

Reset settings = 0000\_0000

Bit	Name	Function
7:1	Reserved	Read returns zero.
0	FSKDAT	<b>FSK Data.</b> When FSKEN = 1 (direct Register 108, bit 6) and REL = 1 (direct Register 32, bit 6), this bit serves as the buffered input for FSK generation bit stream data.

**Register 63. Loop Closure Debounce Interval**

Bit	D7	D6	D5	D4	D3	D2	D1	D0
Name	LCD[7:0]							
Type								

Reset settings = 0101\_0100

Bit	Name	Function
7:0	LCD[7:0]	<b>Loop Closure Debounce Interval for Automatic Ringing.</b> This register sets the loop closure debounce interval for the ringing silent period when using automatic ringing cadences. The value may be set between 0 ms (0x00) and 159 ms (0x7F) in 1.25 ms steps.

## Register 64. Linefeed Control

Bit	D7	D6	D5	D4	D3	D2	D1	D0
Name		LFS[2:0]				LF[2:0]		
Type	R					R/W		

Reset settings = 0000\_0000

Bit	Name	Function
7	Reserved	Read returns zero.
6:4	LFS[2:0]	<p><b>Linefeed Shadow.</b>            This register reflects the actual real time linefeed state. Automatic operations may cause actual linefeed state to deviate from the state defined by linefeed register (e.g., when linefeed equals Ringing state, LFS will equal on-hook transmission state during ringing silent period and Ringing state during ring burst).</p> <p>000 = Open            001 = Forward active            010 = Forward on-hook transmission            011 = TIP open            100 = Ringing            101 = Reverse active            110 = Reverse on-hook transmission            111 = RING open</p>
3	Reserved	Read returns zero.
2:0	LF[2:0]	<p><b>Linefeed.</b>            Writing to this register sets the linefeed state.</p> <p>000 = Open            001 = Forward active            010 = Forward on-hook transmission            011 = TIP open            100 = Ringing            101 = Reverse active            110 = Reverse on-hook transmission            111 = RING open</p>

**Register 65. External Bipolar Transistor Control**

Bit	D7	D6	D5	D4	D3	D2	D1	D0
Name		SQH	CBY	ETBE	ETBO[1:0]		ETBA[1:0]	
Type		R/W	R/W	R/W	R/W		R/W	

Reset settings = 0110\_0001

Bit	Name	Function
7	Reserved	Read returns zero.
6	SQH	<b>Audio Squelch.</b> 0 = No squelch. 1 = STIPAC and SRINGAC pins squelched.
5	CBY	<b>Capacitor Bypass.</b> 0 = Capacitors CP (C1) and CM (C2) in circuit. 1 = Capacitors CP (C1) and CM (C2) bypassed.
4	ETBE	<b>External Transistor Bias Enable.</b> 0 = Bias disabled. 1 = Bias enabled.
3:2	ETBO[1:0]	<b>External Transistor Bias Levels—On-Hook Transmission State.</b> DC bias current which flows through external BJTs in the on-hook transmission state. Increasing this value increases the compliance of the ac longitudinal balance circuit. 00 = 4 mA 01 = 8 mA 10 = 12 mA 11 = Reserved
1:0	ETBA[1:0]	<b>External Transistor Bias Levels—Active Off-Hook State.</b> DC bias current which flows through external BJTs in the active off-hook state. Increasing this value increases the compliance of the ac longitudinal balance circuit. 00 = 4 mA 01 = 8 mA 10 = 12 mA 11 = Reserved

## Register 66. Battery Feed Control

Bit	D7	D6	D5	D4	D3	D2	D1	D0
Name				VOV	FVBAT			TRACK
Type				R/W	R/W			R/W

Reset settings = 0000\_0011

Bit	Name	Function
7:5	Reserved	Read returns zero.
4	VOV	<b>Overhead Voltage Range Increase. (See Figure 19 on page 35.)</b> This bit selects the programmable range for $V_{OV}$ , which is defined in indirect Register 41. 0 = $V_{OV}$ = 0 V to 9 V 1 = $V_{OV}$ = 0 V to 13.5 V
3	FVBAT	<b><math>V_{BAT}</math> Manual Setting.</b> 0 = Normal operation. 1 = $V_{BAT}$ tracks VBATH register.
2:1	Reserved	Read returns zero.
0	TRACK	<b>DC-DC Converter Tracking Mode.</b> 0 = $ V_{BAT} $ will not decrease below VBATL. 1 = $V_{BAT}$ tracks $V_{RING}$ .

**Register 67. Automatic/Manual Control**

Bit	D7	D6	D5	D4	D3	D2	D1	D0
<b>Name</b>		MNCM	MNDIF	SPDS		AORD	AOLD	AOPN
<b>Type</b>		R/W	R/W	R/W		R/W	R/W	R/W

Reset settings = 0001\_1111

Bit	Name	Function
7	Reserved	Read returns zero.
6	MNCM	<b>Common Mode Manual/Automatic Select.</b> 0 = Automatic control. 1 = Manual control, in which TIP (forward) or RING (reverse) forces voltage to follow VCM value.
5	MNDIF	<b>Differential Mode Manual/Automatic Select.</b> 0 = Automatic control. 1 = Manual control (forces differential voltage to follow VOC value).
4	SPDS	<b>Speed-Up Mode Enable.</b> 0 = Speed-up disabled. 1 = Automatic speed-up.
3	Reserved	Read returns zero.
2	AORD	<b>Automatic/Manual Ring Trip Detect.</b> 0 = Manual mode. 1 = Enter off-hook Active state automatically upon ring trip detect.
1	AOLD	<b>Automatic/Manual Loop Closure Detect.</b> 0 = Manual mode. 1 = Enter off-hook Active state automatically upon loop closure detect.
0	AOPN	<b>Power Alarm Automatic/Manual Detect.</b> 0 = Manual mode. 1 = Enter Open state automatically upon power alarm.

## Register 68. Loop Closure/Ring Trip Detect Status

Bit	D7	D6	D5	D4	D3	D2	D1	D0
Name						DBIRAW	RTP	LCR
Type						R	R	R

Reset settings = 0000\_0000

Bit	Name	Function
7:3	Reserved	Read returns zero.
2	DBIRAW	<b>Ring Trip/Loop Closure Unfiltered Output.</b> The state of this bit reflects the real time output of ring trip and loop closure detect circuits before debouncing. 0 = Ring trip/loop closure threshold exceeded. 1 = Ring trip/loop closure threshold not exceeded.
1	RTP	<b>Ring Trip Detect Indicator (Filtered Output).</b> 0 = Ring trip detect has not occurred. 1 = Ring trip detect occurred.
0	LCR	<b>Loop Closure Detect Indicator (Filtered Output).</b> 0 = Loop closure detect has not occurred. 1 = Loop closure detect has occurred.

## Register 69. Loop Closure Debounce Interval

Bit	D7	D6	D5	D4	D3	D2	D1	D0
Name								LCDI[6:0]
Type								R/W

Reset settings = 0000\_1010

Bit	Name	Function
7	Reserved	Read returns zero.
6:0	LCDI[6:0]	<b>Loop Closure Debounce Interval.</b> The value written to this register defines the minimum steady state debounce time. Value may be set between 0 ms (0x00) to 159 ms (0x7F) in 1.25 ms steps. Default value = 12.5 ms.

**Register 70. Ring Trip Detect Debounce Interval**

Bit	D7	D6	D5	D4	D3	D2	D1	D0
<b>Name</b>	RTDI[6:0]							
<b>Type</b>	R/W							

Reset settings = 0000\_1010

Bit	Name	Function
7	Reserved	Read returns zero.
6:0	RTDI[6:0]	<b>Ring Trip Detect Debounce Interval.</b> The value written to this register defines the minimum steady state debounce time. The value may be set between 0 ms (0x00) to 159 ms (0x7F) in 1.25 ms steps. Default value = 12.5 ms.

**Register 71. Loop Current Limit**

Bit	D7	D6	D5	D4	D3	D2	D1	D0
<b>Name</b>							ILIM[2:0]	
<b>Type</b>	R/W							

Reset settings = 0000\_0000

Bit	Name	Function
7:3	Reserved	Read returns zero.
2:0	ILIM[2:0]	<b>Loop Current Limit.</b> The value written to this register sets the constant loop current. The value may be set between 20 mA (0x00) and 41 mA (0x07) in 3 mA steps.

## Register 72. On-Hook Line Voltage

Bit	D7	D6	D5	D4	D3	D2	D1	D0
Name		VSGN	VOC[5:0]					
Type	R/W			R/W				

Reset settings = 0010\_0000

Bit	Name	Function
7	Reserved	Read returns zero.
6	VSGN	<b>On-Hook Line Voltage.</b> The value written to this bit sets the on-hook line voltage polarity ( $V_{TIP}-V_{RING}$ ). 0 = $V_{TIP}-V_{RING}$ is positive. 1 = $V_{TIP}-V_{RING}$ is negative.
5:0	VOC[5:0]	<b>On-Hook Line Voltage.</b> The value written to this register sets the on-hook line voltage ( $V_{TIP}-V_{RING}$ ). Value may be set between 0 V (0x00) and 94.5 V (0x3F) in 1.5 V steps. Default value = 48 V.

## Register 73. Common Mode Voltage

Bit	D7	D6	D5	D4	D3	D2	D1	D0
Name			VCM[5:0]					
Type	R/W							

Reset settings = 0000\_0010

Bit	Name	Function
7:6	Reserved	Read returns zero.
5:0	VCM[5:0]	<b>Common Mode Voltage.</b> The value written to this register sets $V_{TIP}$ for forward active and forward on-hook transmission states and $V_{RING}$ for reverse active and reverse on-hook transmission states. The value may be set between 0 V (0x00) and -94.5 V (0x3F) in 1.5 V steps. Default value = -3 V.



**Register 74. High Battery Voltage**

Bit	D7	D6	D5	D4	D3	D2	D1	D0
<b>Name</b>	VBATH[5:0]							
<b>Type</b>	R/W							

Reset settings = 0011\_0010

Bit	Name	Function
7:6	Reserved	Read returns zero.
5:0	VBATH[5:0]	<b>High Battery Voltage.</b> The value written to this register sets high battery voltage. $V_{BATH}$ must be greater than or equal to $V_{BATL}$ . The value may be set between 0 V (0x00) and -94.5 V (0x3F) in 1.5 V steps. Default value = -75 V.

**Register 75. Low Battery Voltage**

Bit	D7	D6	D5	D4	D3	D2	D1	D0
<b>Name</b>	VBATL[5:0]							
<b>Type</b>	R/W							

Reset settings = 0001\_0000

Bit	Name	Function
7:6	Reserved	Read returns zero.
5:0	VBATL[5:0]	<b>Low Battery Voltage.</b> The value written to this register sets low battery voltage. $V_{BATH}$ must be greater than or equal to $V_{BATL}$ . The value may be set between 0 V (0x00) and -94.5 V (0x3F) in 1.5 V steps. Default value = -24 V.

## Register 76. Power Monitor Pointer

Bit	D7	D6	D5	D4	D3	D2	D1	D0
Name	PWRMP[2:0]							
Type	R/W							

Reset settings = 0000\_0000

Bit	Name	Function
7:3	Reserved	Read returns zero.
2:0	PWRMP[2:0]	<b>Power Monitor Pointer.</b> Selects the external transistor from which to read power output. The power of the selected transistor is read in the PWROM register. 000 = Q1 001 = Q2 010 = Q3 011 = Q4 100 = Q5 101 = Q6 110 = Undefined 111 = Undefined

## Register 77. Line Power Output Monitor

Bit	D7	D6	D5	D4	D3	D2	D1	D0
Name	PWROM[7:0]							
Type	R							

Reset settings = 0000\_0000

Bit	Name	Function
7:0	PWROM[7:0]	<b>Line Power Output Monitor.</b> This register reports the real time power output of the transistor selected using PWRMP. The range is 0 W (0x00) to 7.8 W (0xFF) in 30.4 mW steps for Q1, Q2, Q5, and Q6. The range is 0 W (0x00) to 0.9 W (0xFF) in 3.62 mW steps for Q3 and Q4.

**Register 78. Loop Voltage Sense**

Bit	D7	D6	D5	D4	D3	D2	D1	D0
<b>Name</b>		LVSP	LVS[5:0]					
<b>Type</b>	R			R				

Reset settings = 0000\_0000

Bit	Name	Function
7	Reserved	Read returns zero.
6	LVSP	<b>Loop Voltage Sense Polarity.</b> This register reports the polarity of the differential loop voltage ( $V_{TIP} - V_{RING}$ ). 0 = Positive loop voltage ( $V_{TIP} > V_{RING}$ ). 1 = Negative loop voltage ( $V_{TIP} < V_{RING}$ ).
5:0	LVS[5:0]	<b>Loop Voltage Sense Magnitude.</b> This register reports the magnitude of the differential loop voltage ( $V_{TIP} - V_{RING}$ ). The range is 0 V to 94.5 V in 1.5 V steps.

**Register 79. Loop Current Sense**

Bit	D7	D6	D5	D4	D3	D2	D1	D0
<b>Name</b>		LCSP	LCS[5:0]					
<b>Type</b>	R			R				

Reset settings = 0000\_0000

Bit	Name	Function
7	Reserved	Read returns zero.
6	LCSP	<b>Loop Current Sense Polarity.</b> This register reports the polarity of the loop current. 0 = Positive loop current (forward direction). 1 = Negative loop current (reverse direction).
5:0	LCS[5:0]	<b>Loop Current Sense Magnitude.</b> This register reports the magnitude of the loop current. The range is 0 mA to 78.75 mA in 1.25 mA steps.

## Register 80. TIP Voltage Sense

Bit	D7	D6	D5	D4	D3	D2	D1	D0
Name	VTIP[7:0]							
Type	R							

Reset settings = 0000\_0000

Bit	Name	Function
7:0	VTIP[7:0]	<b>TIP Voltage Sense.</b> This register reports the real time voltage at TIP with respect to ground. The range is 0 V (0x00) to -95.88 V (0xFF) in .376 V steps.

## Register 81. RING Voltage Sense

Bit	D7	D6	D5	D4	D3	D2	D1	D0
Name	VRING[7:0]							
Type	R							

Reset settings = 0000\_0000

Bit	Name	Function
7:0	VRING[7:0]	<b>RING Voltage Sense.</b> This register reports the real time voltage at RING with respect to ground. The range is 0 V (0x00) to -95.88 V (0xFF) in .376 V steps.

## Register 82. Battery Voltage Sense 1

Bit	D7	D6	D5	D4	D3	D2	D1	D0
Name	VBATS1[7:0]							
Type	R							

Reset settings = 0000\_0000

Bit	Name	Function
7:0	VBATS1[7:0]	<b>Battery Voltage Sense 1.</b> This register is one of two registers that reports the real time voltage at $V_{BAT}$ with respect to ground. The range is 0 V (0x00) to -95.88 V (0xFF) in .376 V steps.

**Register 83. Battery Voltage Sense 2**

Bit	D7	D6	D5	D4	D3	D2	D1	D0
<b>Name</b>	VBATS2[7:0]							
<b>Type</b>	R							

Reset settings = 0000\_0000

Bit	Name	Function
7:0	VBATS2[7:0]	<b>Battery Voltage Sense 2.</b> This register is one of two registers that reports the real time voltage at $V_{BAT}$ with respect to ground. The range is 0 V (0x00) to -95.88 V (0xFF) in .376 V steps.

**Register 84. Transistor 1 Current Sense**

Bit	D7	D6	D5	D4	D3	D2	D1	D0
<b>Name</b>	IQ1[7:0]							
<b>Type</b>	R							

Reset settings = xxxx\_xxxx

Bit	Name	Function
7:0	IQ1[7:0]	<b>Transistor 1 Current Sense.</b> This register reports the real time current through Q1. The range is 0 A (0x00) to 81.35 mA (0xFF) in .319 mA steps. If ETBE = 1, the reported value does not include the additional ETBO/A current.

**Register 85. Transistor 2 Current Sense**

Bit	D7	D6	D5	D4	D3	D2	D1	D0
<b>Name</b>	IQ2[7:0]							
<b>Type</b>	R							

Reset settings = xxxx\_xxxx

Bit	Name	Function
7:0	IQ2[7:0]	<b>Transistor 2 Current Sense.</b> This register reports the real time current through Q2. The range is 0 A (0x00) to 81.35 mA (0xFF) in .319 mA steps. If ETBE = 1, the reported value does not include the additional ETBO/A current.

## Register 86. Transistor 3 Current Sense

Bit	D7	D6	D5	D4	D3	D2	D1	D0
Name	IQ3[7:0]							
Type	R							

Reset settings = xxxx\_xxxx

Bit	Name	Function
7:0	IQ3[7:0]	<b>Transistor 3 Current Sense.</b> This register reports the real time current through Q3. The range is 0 A (0x00) to 9.59 mA (0xFF) in 37.6 $\mu$ A steps.

## Register 87. Transistor 4 Current Sense

Bit	D7	D6	D5	D4	D3	D2	D1	D0
Name	IQ4[7:0]							
Type	R							

Reset settings = xxxx\_xxxx

Bit	Name	Function
7:0	IQ4[7:0]	<b>Transistor 4 Current Sense.</b> This register reports the real time current through Q4. The range is 0 A (0x00) to 9.59 mA (0xFF) in 37.6 $\mu$ A steps.

## Register 88. Transistor 5 Current Sense

Bit	D7	D6	D5	D4	D3	D2	D1	D0
Name	IQ5[7:0]							
Type	R							

Reset settings = xxxx\_xxxx

Bit	Name	Function
7:0	IQ5[7:0]	<b>Transistor 5 Current Sense.</b> This register reports the real time current through Q5. The range is 0 A (0x00) to 80.58 mA (0xFF) in .316 mA steps.

**Register 89. Transistor 6 Current Sense**

Bit	D7	D6	D5	D4	D3	D2	D1	D0
<b>Name</b>	IQ6[7:0]							
<b>Type</b>	R							

Reset settings = xxxx\_xxxx

Bit	Name	Function
7:0	IQ6[7:0]	<b>Transistor 6 Current Sense.</b> This register reports the real time current through Q6. The range is 0 A (0x00) to 80.58 mA (0xFF) in .316 mA steps.

**Register 92. DC-DC Converter PWM Period**

Bit	D7	D6	D5	D4	D3	D2	D1	D0
<b>Name</b>	DCN[7]	1	DCN[5:0]					
<b>Type</b>	R/W	R	R/W					

Reset settings = 1111\_1111

Bit	Name	Function
7:0	DCN[7:0]	<b>DC-DC Converter Period.</b> This register sets the PWM period for the dc-dc converter. The range is 3.906 $\mu$ s (0x40) to 15.564 $\mu$ s (0xFF) in 61.035 ns steps. Bit 6 is fixed to one and read-only, so there are two ranges of operation: 3.906–7.751 $\mu$ s, used for MOSFET transistor switching (Si3216M). 11.719–15.564 $\mu$ s, used for BJT transistor switching (Si3216).

## Register 93. DC-DC Converter Switching Delay

Bit	D7	D6	D5	D4	D3	D2	D1	D0
Name	DCCAL		DCPOL	DCTOF[4:0]				
Type	R/W		R	R/W				

Reset settings = 0001\_0100 (Si3216)

Reset settings = 0011\_0100 (Si3216M)

Bit	Name	Function
7	DCCAL	<b>DC-DC Converter Peak Current Monitor Calibration Status.</b> Writing a one to this bit starts the dc-dc converter peak current monitor calibration routine. 0 = Normal operation. 1 = Calibration being performed.
6	Reserved	Read returns zero.
5	DCPOL	<b>DC-DC Converter Feed Forward Pin (DCFF) Polarity.</b> This read-only register bit indicates the polarity relationship of the DCFF pin to the DCDRV pin. Two versions of the Si3216 are offered to support the two relationships. 0 = DCFF pin polarity is opposite of DCDRV pin (Si3216). 1 = DCFF pin polarity is same as DCDRV pin (Si3216M).
4:0	DCTOF[4:0]	<b>DC-DC Converter Minimum Off Time.</b> This register sets the minimum off time for the pulse width modulated dc-dc converter control. $T_{OFF} = (DCTOF + 4) \times 61.035 \text{ ns}$ .

## Register 94. DC-DC Converter PWM Pulse Width

Bit	D7	D6	D5	D4	D3	D2	D1	D0
Name	DCPW[7:0]							
Type	R							

Reset settings = 0000\_0000

Bit	Name	Function
7:0	DCPW[7:0]	<b>DC-DC Converter Pulse Width.</b> Pulse width of DCDRV is given by $PW = (DCPW - DCTOF - 4) \times 61.035 \text{ ns}$ .



**Register 96. Calibration Control/Status Register 1**

Bit	D7	D6	D5	D4	D3	D2	D1	D0
Name		CAL	CALSP	CALR	CALT	CALD	CALC	CALIL
Type		R/W	R/W	R/W	R/W	R/W	R/W	R/W

Reset settings = 0001\_1111

Bit	Name	Function
7	Reserved	Read returns zero.
6	CAL	<b>Calibration Control/Status Bit.</b> Setting this bit begins calibration of the entire system. 0 = Normal operation or calibration complete. 1 = Calibration in progress.
5	CALSP	<b>Calibration Speedup.</b> Setting this bit shortens the time allotted for V <sub>BAT</sub> settling at the beginning of the calibration cycle. 0 = 300 ms 1 = 30 ms
4	CALR	<b>RING Gain Mismatch Calibration.</b> For use with discrete solution only. When using the Si3201, consult “AN35: Si321x User’s Quick Reference Guide” and follow the instructions for manual calibration. 0 = Normal operation or calibration complete. 1 = Calibration enabled or in progress.
3	CALT	<b>TIP Gain Mismatch Calibration.</b> For use with discrete solution only. When using the Si3201, consult “AN35: Si321x User’s Quick Reference Guide” and follow the instructions for manual calibration. 0 = Normal operation or calibration complete. 1 = Calibration enabled or in progress.
2	CALD	<b>Differential DAC Gain Calibration.</b> 0 = Normal operation or calibration complete. 1 = Calibration enabled or in progress.
1	CALC	<b>Common Mode DAC Gain Calibration.</b> 0 = Normal operation or calibration complete. 1 = Calibration enabled or in progress.
0	CALIL	<b>I<sub>LIM</sub> Calibration.</b> 0 = Normal operation or calibration complete. 1 = Calibration enabled or in progress.

## Register 97. Calibration Control/Status Register 2

Bit	D7	D6	D5	D4	D3	D2	D1	D0
Name				CALM1	CALM2	CALDAC	CALADC	
Type				R/W	R/W	R/W	R/W	

Reset settings = 0001\_1110

Bit	Name	Function
7:5	Reserved	Read returns zero.
4	CALM1	<b>Monitor ADC Calibration 1.</b> 0 = Normal operation or calibration complete. 1 = Calibration enabled or in progress.
3	CALM2	<b>Monitor ADC Calibration 2.</b> 0 = Normal operation or calibration complete. 1 = Calibration enabled or in progress.
2	CALDAC	<b>DAC Calibration.</b> Setting this bit begins calibration of the audio DAC offset. 0 = Normal operation or calibration complete. 1 = Calibration enabled or in progress.
1	CALADC	<b>ADC Calibration.</b> Setting this bit begins calibration of the audio ADC offset. 0 = Normal operation or calibration complete. 1 = Calibration enabled or in progress.
0	Reserved	Read returns zero.

**Register 98. RING Gain Mismatch Calibration Result**

Bit	D7	D6	D5	D4	D3	D2	D1	D0
<b>Name</b>						CALGMR[4:0]		
<b>Type</b>	R/W							

Reset settings = 0001\_0000

Bit	Name	Function
7:5	Reserved	Read returns zero.
4:0	CALGMR[4:0]	<b>Gain Mismatch of IE Tracking Loop for RING Current.</b>

**Register 99. TIP Gain Mismatch Calibration Result**

Bit	D7	D6	D5	D4	D3	D2	D1	D0
<b>Name</b>						CALGMT[4:0]		
<b>Type</b>	R/W							

Reset settings = 0001\_0000

Bit	Name	Function
7:5	Reserved	Read returns zero.
4:0	CALGMT[4:0]	<b>Gain Mismatch of IE Tracking Loop for TIP Current.</b>

**Register 100. Differential Loop Current Gain Calibration Result**

Bit	D7	D6	D5	D4	D3	D2	D1	D0
<b>Name</b>						CALGD[4:0]		
<b>Type</b>	R/W							

Reset settings = 0001\_0001

Bit	Name	Function
7:5	Reserved	Read returns zero.
4:0	CALGD[4:0]	<b>Differential DAC Gain Calibration Result.</b>

## Register 101. Common Mode Loop Current Gain Calibration Result

Bit	D7	D6	D5	D4	D3	D2	D1	D0
Name	CALGC[4:0]							
Type	R/W							

Reset settings = 0001\_0001

Bit	Name	Function
7:5	Reserved	Read returns zero.
4:0	CALGC[4:0]	<b>Common Mode DAC Gain Calibration Result.</b>

## Register 102. Current Limit Calibration Result

Bit	D7	D6	D5	D4	D3	D2	D1	D0
Name	CALGIL[3:0]							
Type	R/W							

Reset settings = 0000\_1000

Bit	Name	Function
7:4	Reserved	Read returns zero.
3:0	CALGIL[3:0]	<b>Current Limit Calibration Result.</b>

## Register 103. Monitor ADC Offset Calibration Result

Bit	D7	D6	D5	D4	D3	D2	D1	D0
Name	CALMG1[3:0]				CALMG2[3:0]			
Type	R/W				R/W			

Reset settings = 1000\_1000

Bit	Name	Function
7:4	CALMG1[3:0]	<b>Monitor ADC Offset Calibration Result 1.</b>
3:0	CALMG2[3:0]	<b>Monitor ADC Offset Calibration Result 2.</b>

**Register 104. Analog DAC/ADC Offset**

Bit	D7	D6	D5	D4	D3	D2	D1	D0
Name					DACP	DACN	ADCP	ADCN
Type					R/W	R/W	R/W	R/W

Reset settings = 0000\_0000

Bit	Name	Function
7:4	Reserved	Read returns zero.
3	DACP	<b>Positive Analog DAC Offset.</b>
2	DACN	<b>Negative Analog DAC Offset.</b>
1	ADCP	<b>Positive Analog ADC Offset.</b>
0	ADCN	<b>Negative Analog ADC Offset.</b>

**Register 105. DAC Offset Calibration Result**

Bit	D7	D6	D5	D4	D3	D2	D1	D0
Name	DACOF[7:0]							
Type	R/W							

Reset settings = 0000\_0000

Bit	Name	Function
7:0	DACOF[7:0]	<b>DAC Offset Calibration Result.</b>

**Register 107. DC Peak Current Monitor Calibration Result**

Bit	D7	D6	D5	D4	D3	D2	D1	D0
Name					CMDCPK[3:0]			
Type	R/W							

Reset settings = 0000\_1000

Bit	Name	Function
7:4	Reserved	Read returns zero.
3:0	CMDCPK[3:0]	<b>DC Peak Current Monitor Calibration Result.</b>

**Register 108. Enhancement Enable**

Bit	D7	D6	D5	D4	D3	D2	D1	D0
<b>Name</b>	ILIMEN	FSKEN	DCSU			LCVE	DCFIL	HYSTEN
<b>Type</b>	R/W	R/W	R/W			R/W	R/W	R/W

Reset settings = 0000\_0000

Bit	Name	Function
7	ILIMEN	<p><b>Current Limit Increase.</b></p> <p>When enabled, this bit temporarily increases the maximum differential current limit at the end of a ring burst to enable a faster settling time to a dc linefeed state.</p> <p>0 = The value programmed in ILIM (direct Register 71) is used.</p> <p>1 = The maximum differential loop current limit is temporarily increased to 41 mA.</p>
6	FSKEN	<p><b>FSK Generation Enhancement.</b></p> <p>When enabled, this bit will increase the clocking rate of tone generator 1 to 24 kHz only when the REL bit (direct Register 32, bit 6) is set. Also, dedicated oscillator registers are used for FSK generation (indirect registers 99–104). Audio tones are generated using this new higher frequency, and oscillator 1 active and inactive timers have a finer bit resolution of 41.67 <math>\mu</math>s. This provides greater resolution during FSK caller ID signal generation.</p> <p>0 = Tone generator always clocked at 8 kHz; OSC1, OSC1X., and OSC1Y are always used.</p> <p>1 = Tone generator module clocked at 24 kHz and dedicated FSK registers used only when REL = 1; otherwise clocked at 8 kHz.</p>
5	DCSU	<p><b>DC-DC Converter Control Speedup.</b></p> <p>When enabled, this bit invokes a multi-threshold error control algorithm which allows the dc-dc converter to adjust more quickly to voltage changes.</p> <p>0 = Normal control algorithm used.</p> <p>1 = Multi-threshold error control algorithm used.</p>
4	Reserved	Write has no effect.
3	Reserved	Read returns zero.
2	LCVE	<p><b>Voltage-Based Loop Closure.</b></p> <p>Enables loop closure to be determined by the TIP-to-RING voltage rather than loop current.</p> <p>0 = Loop closure determined by loop current.</p> <p>1 = Loop closure determined by TIP-to-RING voltage.</p>

Bit	Name	Function
1	DCFIL	<b>DC-DC Converter Squelch.</b> When enabled, this bit squelches noise in the audio band from the dc-dc converter control loop. 0 = Voice band squelch disabled. 1 = Voice band squelch enabled.
0	HYSTEN	<b>Loop Closure Hysteresis Enable.</b> When enabled, this bit allows hysteresis to the loop closure calculation. The upper and lower hysteresis thresholds are defined by Indirect Registers 28 and 43, respectively. 0 = Loop closure hysteresis disabled. 1 = Loop closure hysteresis enabled.

Not recommended for new designs.  
Please note the Si3201 has been discontinued.

## 4. Indirect Registers

Indirect registers are not directly mapped into memory but are accessible through the IDA and IAA registers. A write to IDA followed by a write to IAA is interpreted as a write request to an indirect register. In this case, the contents of IDA are written to indirect memory at the location referenced by IAA at the next indirect register update. A write to IAA without first writing to IDA is interpreted as a read request from an indirect register. In this case, the value located at IAA is written to IDA at the next indirect register update. Indirect registers are updated at a rate of 16 kHz. For pending indirect register transfers, IAS (direct Register 31) will be one until serviced. In addition, an interrupt, IND (Register 20), can be generated upon completion of the indirect transfer.

The indirect memory map is different from what is described in the data sheet. The indirect memory map is as follows:

**Table 35. Si3210 to Si3216 Indirect Register Cross Reference**

Si3210 Indirect Register	Si3216 Indirect Register	Indirect Register Name	Si3210 Indirect Register	Si3216 Indirect Register	Indirect Register Name	Si3210 Indirect Register	Si3216 Indirect Register	Indirect Register Name
13	0	OSC1	27	14	ADCG	38	25	NQ34
14	1	OSC1X	28	15	LCRT	39	26	NQ56
15	2	OSC1Y	29	16	RPTP	40	27	VCMR
16	3	OSC2	30	17	CML	41	64	VMIND
17	4	OSC2X	31	18	CMH	43	66	LCRTL
18	5	OSC2Y	32	19	PPT12	99	69	FSK0X
19	6	ROFF	33	20	PPT34	100	70	FSK0
20	7	RCO	34	21	PPT56	101	71	FSK1X
21	8	RNGX	35	22	NCLR	102	72	FSK1
22	9	RNGY	36	23	NRTP	103	73	FSK01
26	13	DACG	37	24	NQ12	104	74	FSK10

### 4.1. Oscillators

See functional description sections of tone generation, ringing, and pulse metering for guidelines on computing register values. All values are represented in 2s-complement format.

**Note:** The values of all indirect registers are undefined following the reset state. Shaded areas denote bits that can be read and written but should be written to zeroes.

**Table 36. Oscillator Indirect Registers Summary**

Addr.	D15	D14	D13	D12	D11	D10	D9	D8	D7	D6	D5	D4	D3	D2	D1	D0
0	OSC1[15:0]															
1	OSC1X[15:0]															
2	OSC1Y[15:0]															
3	OSC2[15:0]															
4	OSC2X[15:0]															
5	OSC2Y[15:0]															
6																



Table 36. Oscillator Indirect Registers Summary (Continued)

Addr.	D15	D14	D13	D12	D11	D10	D9	D8	D7	D6	D5	D4	D3	D2	D1	D0
7	RCO[15:0]															
8	RNGX[15:0]															
9	RNGY[15:0]															

Table 37. Oscillator Indirect Registers Description

Addr.	Description	Reference Page
0	<b>Oscillator 1 Frequency Coefficient.</b> Sets tone generator 1 frequency.	37
1	<b>Oscillator 1 Amplitude Register.</b> Sets tone generator 1 signal amplitude.	37
2	<b>Oscillator 1 Initial Phase Register.</b> Sets initial phase of tone generator 1 signal.	37
3	<b>Oscillator 2 Frequency Coefficient.</b> Sets tone generator 2 frequency.	37
4	<b>Oscillator 2 Amplitude Register.</b> Sets tone generator 2 signal amplitude.	37
5	<b>Oscillator 2 Initial Phase Register.</b> Sets initial phase of tone generator 2 signal.	37
6	<b>Ringling Oscillator DC Offset.</b> Sets dc offset component ( $V_{TIP}-V_{RING}$ ) to ringling waveform. The range is 0 to 94.5 V in 1.5 V increments.	39
7	<b>Ringling Oscillator Frequency Coefficient.</b> Sets ringling generator frequency.	39
8	<b>Ringling Oscillator Amplitude Register.</b> Sets ringling generator signal amplitude.	39
9	<b>Ringling Oscillator Initial Phase Register.</b> Sets initial phase of ringling generator signal.	39

## 4.2. Digital Programmable Gain/Attenuation

See functional description sections of digital programmable gain/attenuation for guidelines on computing register values. All values are represented in 2s-complement format.

**Note:** The values of all indirect registers are undefined following the reset state. Shaded areas denote bits that can be read and written but should be written to zeros.

Table 38. Digital Programmable Gain/Attenuation Indirect Registers Summary

Addr.	D15	D14	D13	D12	D11	D10	D9	D8	D7	D6	D5	D4	D3	D2	D1	D0
13	DACG[11:0]															
14	ADCG[11:0]															

**Table 39. Digital Programmable Gain/Attenuation Indirect Registers Description**

Addr.	Description	Reference Page
13	<b>Receive Path Digital to Analog Converter Gain/Attenuation.</b> This register sets gain/attenuation for the receive path. The digitized signal is effectively multiplied by DACG to achieve gain/attenuation. A value of 0x00 corresponds to $-\infty$ dB gain (mute). A value of 0x400 corresponds to unity gain. A value of 0x7FF corresponds to a gain of 6 dB.	43
14	<b>Transmit Path Analog to Digital Converter Gain/Attenuation.</b> This register sets gain/attenuation for the transmit path. The digitized signal is effectively multiplied by ADCG to achieve gain/attenuation. A value of 0x00 corresponds to $-\infty$ dB gain (mute). A value of 0x400 corresponds to unity gain. A value of 0x7FF corresponds to a gain of 6 dB.	43

Not recommended for new designs.  
Please note the Si3201 has been discontinued.

### 4.3. SLIC Control

See descriptions of linefeed interface and power monitoring for guidelines on computing register values. All values are represented in 2s-complement format.

**Note:** The values of all indirect registers are undefined following the reset state. Shaded areas denote bits that can be read and written but should be written to zeroes.

**Table 40. SLIC Control Indirect Registers Summary**

Addr.	D15	D14	D13	D12	D11	D10	D9	D8	D7	D6	D5	D4	D3	D2	D1	D0
15				LCRT[5:0]												
16				RPTP[5:0]												
17				CML[5:0]												
18				CMH[5:0]												
19				PPT12[7:0]												
20				PPT34[7:0]												
21				PPT56[7:0]												
22				NCLR[12:0]												
23				NRTP[12:0]												
24				NQ12[12:0]												
25				NQ34[12:0]												
26				NQ56[12:0]												
27				VCMR[3:0]												
64				VMIND[3:0]												
66				LCRTL[5:0]												

**Table 41. SLIC Control Indirect Registers Description**

Addr.	Description	Reference Page
15	<b>Loop Closure Threshold.</b> Loop closure detection threshold. This register defines the upper bounds threshold if hysteresis is enabled (direct Register 108, bit 0). The range is 0–80 mA in 1.27 mA steps.	32
16	<b>Ring Trip Threshold.</b> Ring trip detection threshold during ringing.	42
17	<b>Common Mode Minimum Threshold for Speed-Up.</b> This register defines the negative common mode voltage threshold. Exceeding this threshold enables a wider bandwidth of dc linefeed control for faster settling times. The range is 0–23.625 V in 0.375 V steps.	
18	<b>Common Mode Maximum Threshold for Speed-Up.</b> This register defines the positive common mode voltage threshold. Exceeding this threshold enables a wider bandwidth of dc linefeed control for faster settling times. The range is 0–23.625 V in 0.375 V steps.	

Table 41. SLIC Control Indirect Registers Description (Continued)

Addr.	Description	Reference Page
19	<b>Power Alarm Threshold for Transistors Q1 and Q2.</b>	30
20	<b>Power Alarm Threshold for Transistors Q3 and Q4.</b>	30
21	<b>Power Alarm Threshold for Transistors Q5 and Q6.</b>	30
22	<b>Loop Closure Filter Coefficient.</b>	32
23	<b>Ring Trip Filter Coefficient.</b>	42
24	<b>Thermal Low Pass Filter Pole for Transistors Q1 and Q2.</b>	30
25	<b>Thermal Low Pass Filter Pole for Transistors Q3 and Q4.</b>	30
26	<b>Thermal Low Pass Filter Pole for Transistors Q5 and Q6.</b>	30
27	<b>Common Mode Bias Adjust During Ringing.</b> Recommended value of 0 decimal.	39
64	<b>DC-DC Converter <math>V_{OV}</math> Voltage.</b> This register sets the overhead voltage, $V_{OV}$ , to be supplied by the dc-dc converter. When the VOV bit = 0 (direct Register 66, bit 4), $V_{OV}$ should be set between 0 and 9 V (VMIND = 0 to 6h). When the VOV bit = 1, $V_{OV}$ should be set between 0 and 13.5 V (VMIND = 0 to 9h).	33
66	<b>Loop Closure Threshold—Lower Bound.</b> This register defines the lower threshold for loop closure hysteresis, which is enabled in bit 0 of direct Register 108. The range is 0–80 mA in 1.27 mA steps.	32

#### 4.4. FSK Control

For detailed instructions on FSK signal generation, refer to “Application Note 32: FSK Generation” (AN32). These registers support enhanced FSK generation mode, which is enabled by setting FSKEN = 1 (direct Register 108, bit 6) and REL = 1 (direct Register 32, bit 6).

**Table 42. FSK Control Indirect Registers Summary**

Addr.	D15	D14	D13	D12	D11	D10	D9	D8	D7	D6	D5	D4	D3	D2	D1	D0
69	FSK0X[15:0]															
70	FSK0[15:0]															
71	FSK1X[15:0]															
72	FSK1[15:0]															
73	FSK01[15:0]															
74	FSK10[15:0]															

**Table 43. FSK Control Indirect Registers Description**

Addr.	Description	Reference Page
69	<b>FSK Amplitude Coefficient for Space.</b> When FSKEN = 1 and REL = 1, this register sets the amplitude to be used when generating a space or 0. When the active timer (OAT1) expires, the value of this register is loaded into oscillator 1 instead of OSC1X.	39 and AN32
70	<b>FSK Frequency Coefficient for Space.</b> When FSKEN = 1 and REL = 1, this register sets the frequency to be used when generating a space or 0. When the active timer (OAT1) expires, the value of this register is loaded into oscillator 1 instead of OSC1.	39 and AN32
71	<b>FSK Amplitude Coefficient for Mark.</b> When FSKEN = 1 and REL = 1, this register sets the amplitude to be used when generating a mark or 1. When the active timer (OAT1) expires, the value of this register is loaded into oscillator 1 instead of OSC1X.	39 and AN32
72	<b>FSK Frequency Coefficient for Mark.</b> When FSKEN = 1 and REL = 1, this register sets the frequency to be used when generating a mark or 1. When the active timer (OAT1) expires, the value of this register is loaded into oscillator 1 instead of OSC1.	39 and AN32
73	<b>FSK Transition Parameter from 0 to 1.</b> When FSKEN = 1 and REL = 1, this register defines a gain correction factor that is applied to signal amplitude when transitioning from a space (0) to a mark (1).	39 and AN32
74	<b>FSK Transition Parameter from 1 to 0.</b> When FSKEN = 1 and REL = 1, this register defines a gain correction factor that is applied to signal amplitude when transitioning from a mark (1) to a space (0).	39 and AN32

## 5. Pin Descriptions: Si3216

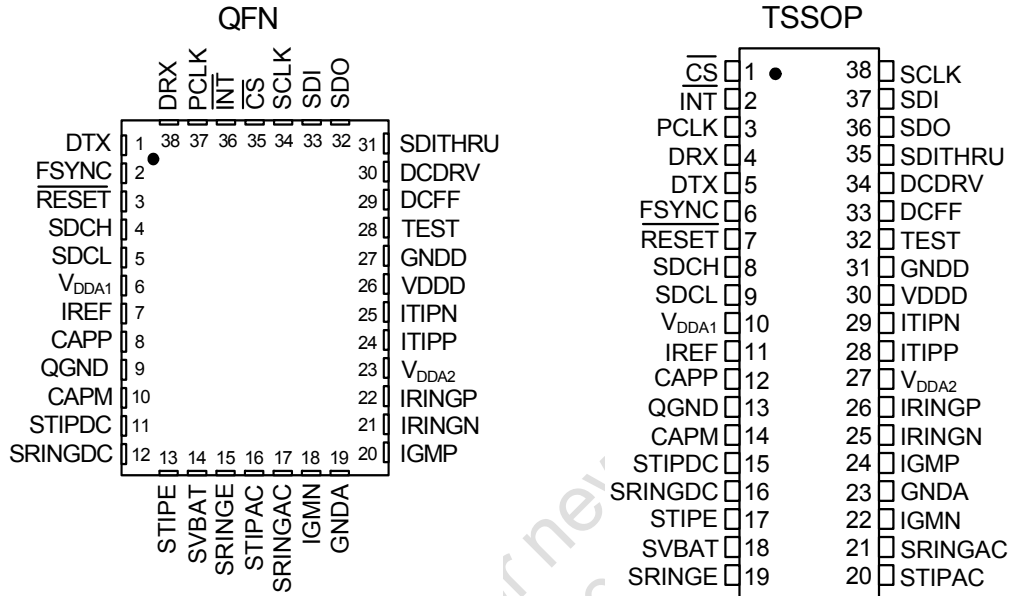

Pin # QFN	Pin # TSSOP	Name	Description
35	1	$\overline{\text{CS}}$	<b>Chip Select.</b> Active low. When inactive, SCLK and SDI are ignored and SDO is high-impedance. When active, the serial port is operational.
36	2	$\overline{\text{INT}}$	<b>Interrupt.</b> Maskable interrupt output. Open drain output for wire-ORed operation.
37	3	PCLK	<b>PCM Bus Clock.</b> Clock input for PCM bus timing.
38	4	DRX	<b>Receive PCM Data.</b> Input data from PCM bus.
1	5	DTX	<b>Transmit PCM Data.</b> Output data to PCM bus.
2	6	FSYNC	<b>Frame Synch.</b> 8 kHz frame synchronization signal for the PCM bus. May be short or long pulse format.
3	7	$\overline{\text{RESET}}$	<b>Reset.</b> Active low input. Hardware reset used to place all control registers in the default state.
4	8	SDCH	<b>DC Monitor.</b> DC-DC converter monitor input used to detect overcurrent situations in the converter.

Pin # QFN	Pin # TSSOP	Name	Description
5	9	SDCL	<b>DC Monitor.</b> DC-DC converter monitor input used to detect overcurrent situations in the converter.
6	10	VDDA1	<b>Analog Supply Voltage.</b> Analog power supply for internal analog circuitry.
7	11	IREF	<b>Current Reference.</b> Connects to an external resistor used to provide a high accuracy reference current.
8	12	CAPP	<b>SLIC Stabilization Capacitor.</b> Capacitor used in low pass filter to stabilize SLIC feedback loops.
9	13	QGND	<b>Component Reference Ground.</b>
10	14	CAPM	<b>SLIC Stabilization Capacitor.</b> Capacitor used in low pass filter to stabilize SLIC feedback loops.
11	15	STIPDC	<b>TIP Sense.</b> Analog current input used to sense voltage on the TIP lead.
12	16	SRINGDC	<b>RING Sense.</b> Analog current input used to sense voltage on the RING lead.
13	17	STIPE	<b>TIP Emitter Sense.</b> Analog current input used to sense voltage on the Q6 emitter lead.
14	18	SVBAT	<b>VBAT Sense.</b> Analog current input used to sense voltage on dc-dc converter output voltage lead.
15	19	SRINGE	<b>RING Emitter Sense.</b> Analog current input used to sense voltage on the Q5 emitter lead.
16	20	STIPAC	<b>TIP Transmit Input.</b> Analog ac input used to detect voltage on the TIP lead.
17	21	SRINGAC	<b>RING Transmit Input.</b> Analog ac input used to detect voltage on the RING lead.
18	22	IGMN	<b>Transconductance Amplifier External Resistor.</b> Negative connection for transconductance gain setting resistor.
19	23	GND A	<b>Analog Ground.</b> Ground connection for internal analog circuitry.
20	24	IGMP	<b>Transconductance Amplifier External Resistor.</b> Positive connection for transconductance gain setting resistor.
21	25	IRINGN	<b>Negative Ring Current Control.</b> Analog current output driving Q3.
22	26	IRINGP	<b>Positive Ring Current Control.</b> Analog current output driving Q2.
23	27	VDDA2	<b>Analog Supply Voltage.</b> Analog power supply for internal analog circuitry.

# Si3216

Pin # QFN	Pin # TSSOP	Name	Description
24	28	ITIPP	<b>Positive TIP Current Control.</b> Analog current output driving Q1.
25	29	ITIPN	<b>Negative TIP Current Control.</b> Analog current output driving Q4.
26	30	VDDD	<b>Digital Supply Voltage.</b> Digital power supply for internal digital circuitry.
27	31	GNDD	<b>Digital Ground.</b> Ground connection for internal digital circuitry.
28	32	TEST	<b>Test.</b> Enables test modes for Silicon Labs internal testing. This pin should always be tied to ground for normal operation.
29	33	DCFF	<b>DC Feed-Forward/High Current General Purpose Output.</b> Feed-forward drive of external bipolar transistors to improve dc-dc converter efficiency.
30	34	DCDRV	<b>DC Drive/Battery Switch.</b> DC-DC converter control signal output which drives external bipolar transistor.
31	35	SDITHRU	<b>SDI Passthrough.</b> Cascaded SDI output signal for daisy-chain mode.
32	36	SDO	<b>Serial Port Data Out.</b> Serial port control data output.
33	37	SDI	<b>Serial Port Data In.</b> Serial port control data input.
34	38	SCLK	<b>Serial Port Bit Clock Input.</b> Serial port clock input. Controls the serial data on SDO and latches the data on SDI.



## 6. Pin Descriptions: Si3201

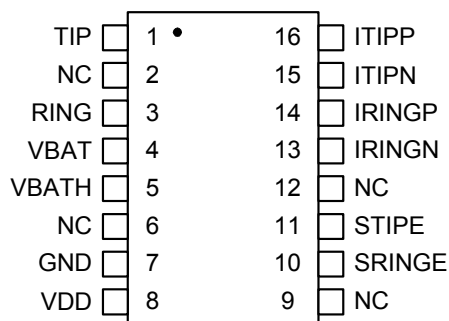

Pin #	Name	Input/Output	Description
1	TIP	I/O	<b>TIP Output</b> —Connect to the TIP lead of the subscriber loop.
2, 6, 9, 12	NC		<b>No Internal Connection</b> —Do not connect to any electrical signal.
3	RING	I/O	<b>RING Output</b> —Connect to the RING lead of the subscriber loop.
4	VBAT		<b>Operating Battery Voltage</b> —Connect to the battery supply.
5	VBATH		<b>High Battery Voltage</b> —This pin is internally connected to VBAT.
7	GND		<b>Ground</b> —Connect to a low impedance ground plane.
8	VDD		<b>Supply Voltage</b> —Main power supply for all internal circuitry. Connect to a 3.3 V or 5 V supply. Decouple locally with a 0.1 $\mu$ F/6 V capacitor.
10	SRINGE	O	<b>RING Emitter Sense Output</b> —Connect to the SRINGE pin of the Si321x pin.
11	STIPE	O	<b>TIP Emitter Sense Output</b> —Connect to the STIPE pin of the Si321x pin.
13	IRINGN	I	<b>Negative RING Current Control</b> —Connect to the IRINGN lead of the Si321x.
14	IRINGP	I	<b>Positive RING Current Drive</b> —Connect to the IRINGP lead of the Si321x.
15	ITIPN	I	<b>Negative TIP Current Control</b> —Connect to the ITIPN lead of the Si321x.
16	ITIPP	I	<b>Positive TIP Current Control</b> —Connect to the ITIPP lead of the Si321x.
Bottom-Side Exposed Pad			<b>Exposed Thermal Pad</b> —Connect to the bulk ground plane.

## 7. Ordering Guides

**Table 44. Device Ordering Guide**

Device	Description	Wideband Codec	DCFF Pin Output	Package	Lead-Free and RoHS-Compliant	Temperature
Si3216-C-FM	ProSLIC	✓	$\overline{\text{DCDRV}}$	QFN-38	Yes	0 to 70 °C
Si3216-C-GM	ProSLIC	✓	$\overline{\text{DCDRV}}$	QFN-38	Yes	-40 to 85 °C
Si3216M-C-FM	ProSLIC	✓	DCDRV	QFN-38	Yes	0 to 70 °C
Si3216M-C-GM	ProSLIC	✓	DCDRV	QFN-38	Yes	-40 to 85 °C
Si3216-KT	ProSLIC	✓	$\overline{\text{DCDRV}}$	TSSOP-38	No	0 to 70 °C
Si3216-BT	ProSLIC	✓	$\overline{\text{DCDRV}}$	TSSOP-38	No	-40 to 85 °C
Si3216-FT	ProSLIC	✓	$\overline{\text{DCDRV}}$	TSSOP-38	Yes	0 to 70 °C
Si3216-GT	ProSLIC	✓	$\overline{\text{DCDRV}}$	TSSOP-38	Yes	-40 to 85 °C
Si3216M-KT	ProSLIC	✓	DCDRV	TSSOP-38	No	0 to 70 °C
Si3216M-BT	ProSLIC	✓	DCDRV	TSSOP-38	No	-40 to 85 °C
Si3216M-FT	ProSLIC	✓	DCDRV	TSSOP-38	Yes	0 to 70 °C
Si3216M-GT	ProSLIC	✓	DCDRV	TSSOP-38	Yes	-40 to 85 °C
Si3201-KS	Linefeed Interface		N/A	SOIC-16	No	0 to 70 °C
Si3201-BS	Linefeed Interface		N/A	SOIC-16	No	-40 to 85 °C
Si3201-FS	Linefeed Interface		N/A	SOIC-16	Yes	0 to 70 °C
Si3201-GS	Linefeed Interface		N/A	SOIC-16	Yes	-40 to 85 °C

**Note:** Add an "R" at the end of the device to denote tape and reel option; 2500 quantity per reel.

Table 45. Evaluation Kit Ordering Guide

Item	Supported ProSLIC	Description	Linefeed Interface
Si3216PPQX-EVB	Si3216-QFN	Eval Board, Daughter Card	Discrete
Si3216PPQ1-EVB	Si3216-QFN	Eval Board, Daughter Card	Si3201
Si3216DCQX-EVB	Si3216-QFN	Daughter Card Only	Discrete
Si3216DCQ1-EVB	Si3216-QFN	Daughter Card Only	Si3201
Si3216MPPQX-EVB	Si3216M-QFN	Eval Board, Daughter Card	Discrete
Si3216MPPQ1-EVB	Si3216M-QFN	Eval Board, Daughter Card	Si3201
Si3216MDCQ1-EVB	Si3216M-QFN	Daughter Card Only	Si3201
Si3216MDCQX-EVB	Si3216M-QFN	Daughter Card Only	Discrete
Si3216PPTX-EVB	Si3216-TSSOP	Eval Board, Daughter Card	Discrete
Si3216PPT1-EVB	Si3216-TSSOP	Eval Board, Daughter Card	Si3201
Si3216DCX-EVB	Si3216-TSSOP	Daughter Card Only	Discrete
Si3216DC1-EVB	Si3216-TSSOP	Daughter Card Only	Si3201

Not recommended for new designs.  
Please note the Si3201 is discontinued.

## 8. Package Outline: 38-Pin QFN

Figure 30 illustrates the package details for the Si321x. Table 46 lists the values for the dimensions shown in the illustration.

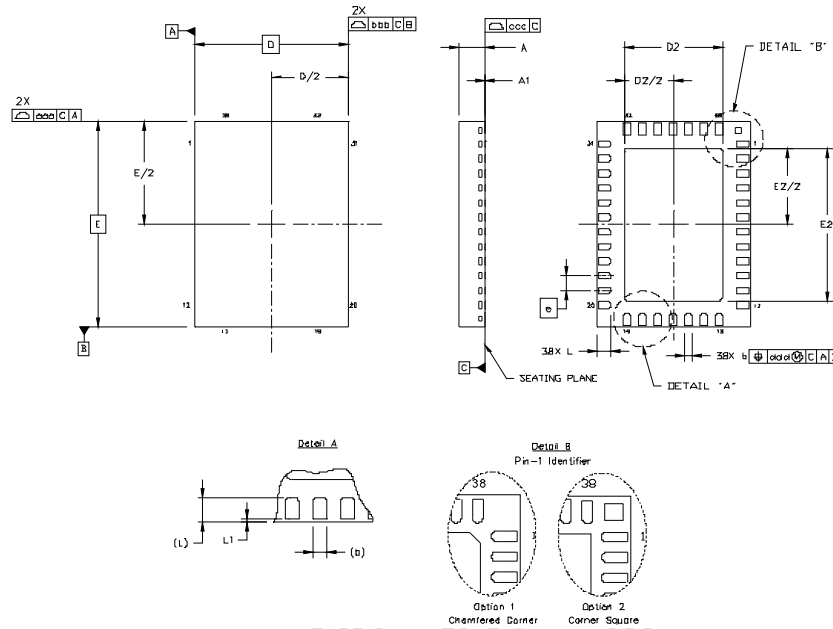

Figure 30. 38-Pin Quad Flat No-Lead Package (QFN)

Table 46. Package Diagram Dimensions<sup>1,2,3</sup>

Symbol	Millimeters		
	Min	Nom	Max
A	0.75	0.85	0.95
A1	0.00	0.01	0.05
b	0.18	0.23	0.30
D	5.00 BSC.		
D2	3.10	3.20	3.30
e	0.50 BSC.		
E	7.00 BSC.		
E2	5.10	5.20	5.30
L	0.35	0.45	0.55
L1	0.03	0.05	0.08
aaa	—	—	0.10
bbb	—	—	0.10
ccc	—	—	0.08
ddd	—	—	0.10
<b>Notes:</b>			
1. All dimensions shown are in millimeters (mm) unless otherwise noted.			
2. Dimensioning and Tolerancing per ANSI Y14.5M-1982.			
3. Recommended card reflow profile is per the JEDEC/IPC J-STD-020C specification for Small Body Components.			

## 9. Package Outline: 38-Pin TSSOP

Figure 31 illustrates the package details for the Si321x. Table 47 lists the values for the dimensions shown in the illustration.

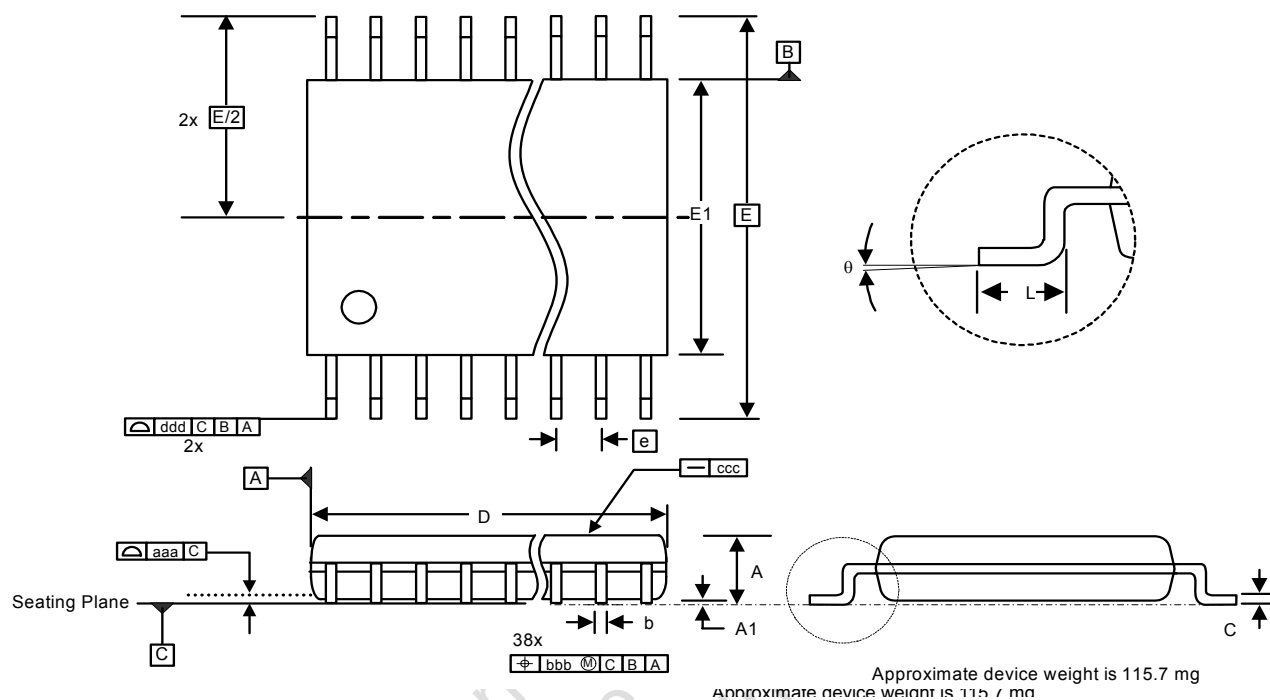

Figure 31. 38-Pin Thin Shrink Small Outline Package (TSSOP)

Table 47. Package Diagram Dimensions

Symbol	Millimeters		
	Min	Nom	Max
A	—	—	1.20
A1	0.05	—	0.15
b	0.17	—	0.27
c	0.09	—	0.20
D	9.60	9.70	9.80
e	0.50 BSC		
E	6.40 BSC		
E1	4.30	4.40	4.50
L	0.45	0.60	0.75
$\theta$	0°	—	8°
aaa	0.10		
bbb	0.08		
ccc	0.05		
ddd	0.20		

## 10. Package Outline: 16-Pin ESOIC

Figure 32 illustrates the package details for the Si3201. Table 48 lists the values for the dimensions shown in the illustration.

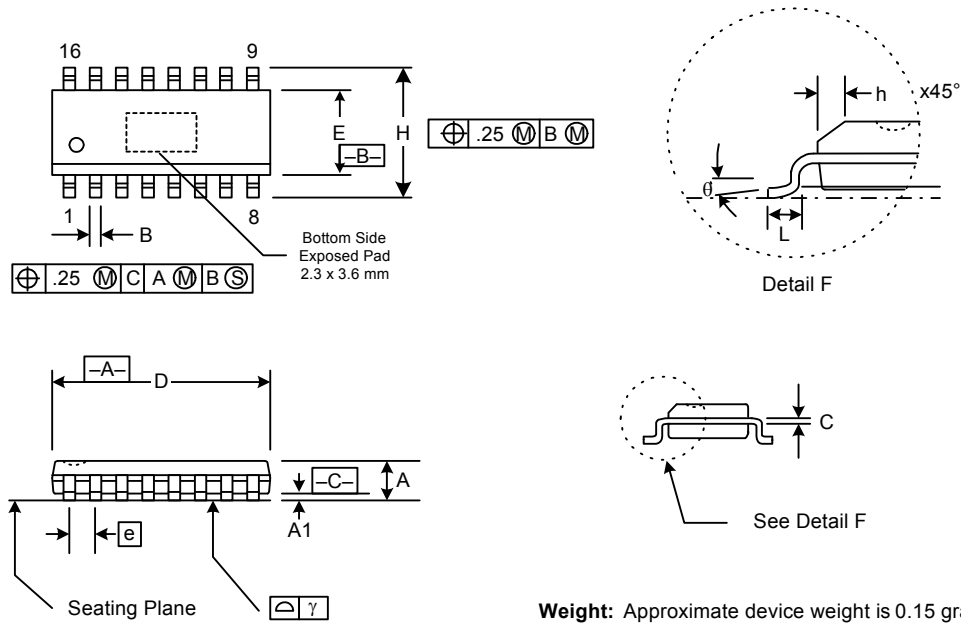

**Figure 32. 16-Pin Thermal Enhanced Small Outline Integrated Circuit (ESOIC) Package**

**Table 48. Package Diagram Dimensions**

Symbol	Millimeters	
	Min	Max
A	1.35	1.75
A1	0	0.15
B	.33	.51
C	.19	.25
D	9.80	10.00
E	3.80	4.00
e	1.27 BSC	
H	5.80	6.20
h	.25	.50
L	.40	1.27
$\gamma$	—	0.10
$\theta$	0°	8°

## 11. Silicon Labs Si3216 Support Documentation

- AN32: Si321x Frequency Shift Keying (FSK) Modulation
- AN33: Si321x Neon Flashing
- AN34: Si321x Hardware Reference Guide
- AN35: Si321x User's Quick Reference Guide
- AN39: Connecting the ProSLIC to the W & G PCM-4
- AN45: Design Guide for the Si321x DC-DC Converter
- AN46: Demonstration Software Guide for the Si3210 DC-DC Converter
- AN47: Si321x Linefeed Power Monitoring and Protection
- Si321xPPT-EVB: Evaluation board data sheet

**Note:** Refer to [www.silabs.com](http://www.silabs.com) for a current list of support documents for this chipset.

Not recommended for new designs.  
Please note the Si3201 has been discontinued.

## DOCUMENT CHANGE LIST

### Revision 0.61 to Revision 0.9

- Separated the Si3216/15 document into two data sheets.
- Added Quad Flat No-Lead (QFN) package.
- Removed references to Si3215.
- Updated Figure 11 on page 20.
  - Changed C18, C19 from 1.0  $\mu$ F to 4.7  $\mu$ F.
- Updated Figure 13 on page 23.
  - Changed C10 from 22 nF to 0.1  $\mu$ F.
- Updated Table 11 on page 18.
  - Changed delay time between chip selects,  $t_{CS}$ , from 220 ns to 440 ns
- Updated Table 41 on page 107.
  - Changed recommended values for Indirect Register 27 from 6 to 0.
- Updated 7."Ordering Guides" on page 114.

### Revision 0.9 to Revision 0.91

- Figure 12 on page 22.
  - Added optional components to application schematic to improve idle channel noise.
- Table 14 on page 22.
  - Added TO-92 transistor suppliers to BOM.
- Table 45, "Evaluation Kit Ordering Guide," on page 115.
  - Updated to include Si3216M-QFN daughter card.
- Table 48, "Package Diagram Dimensions," on page 118.
  - Changed A1 from 0.10 to 0.15.
- 7."Ordering Guides" on page 114.
  - Updated table to include product revision designator.

### Rev. C Si3216 Silicon:

- Register 14. Powerdown Control 1 on page 64.
  - Changed Bit 3 from "Monitor ADC Power-Off Control" to "PLL Free-Run Control"

### Revision 0.91 to Revision 1.0

- Added chamfered Pin 1 identifier option to Package Outline: 38-Pin QFN.
- Clarified Ordering Guide
  - Replaced "X" with revision letter "C" in all ordering codes requiring a revision letter.
  - Removed Note 2 from Ordering Guide



**NOTES:**

Not recommended for new designs.  
Please note the Si3201 has been discontinued.

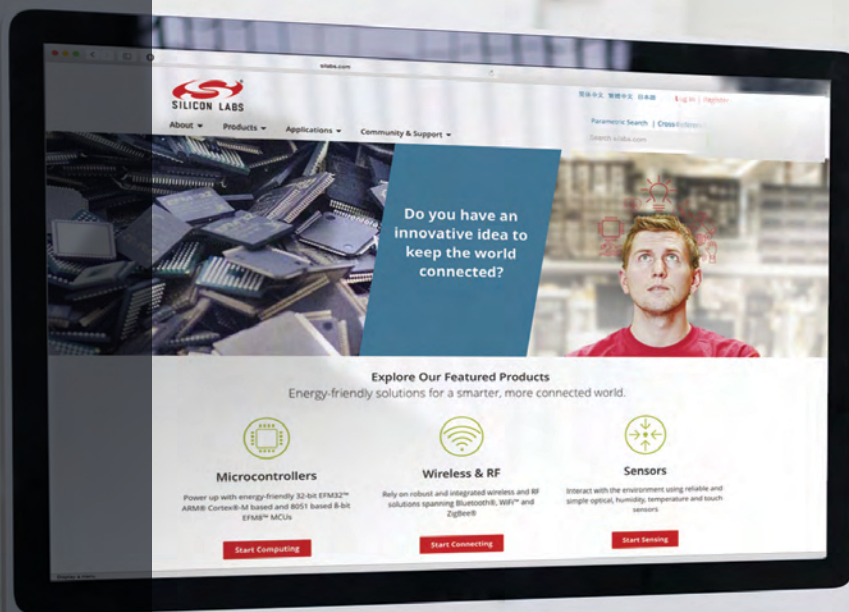

Smart.  
Connected.  
Energy-Friendly



Products  
[www.silabs.com/products](http://www.silabs.com/products)



Quality  
[www.silabs.com/quality](http://www.silabs.com/quality)



Support and Community  
[community.silabs.com](http://community.silabs.com)

#### Disclaimer

Silicon Laboratories intends to provide customers with the latest, accurate, and in-depth documentation of all peripherals and modules available for system and software implementers using or intending to use the Silicon Laboratories products. Characterization data, available modules and peripherals, memory sizes and memory addresses refer to each specific device, and "Typical" parameters provided can and do vary in different applications. Application examples described herein are for illustrative purposes only. Silicon Laboratories reserves the right to make changes without further notice and limitation to product information, specifications, and descriptions herein, and does not give warranties as to the accuracy or completeness of the included information. Silicon Laboratories shall have no liability for the consequences of use of the information supplied herein. This document does not imply or express copyright licenses granted hereunder to design or fabricate any integrated circuits. The products must not be used within any Life Support System without the specific written consent of Silicon Laboratories. A "Life Support System" is any product or system intended to support or sustain life and/or health, which, if it fails, can be reasonably expected to result in significant personal injury or death. Silicon Laboratories products are generally not intended for military applications. Silicon Laboratories products shall under no circumstances be used in weapons of mass destruction including (but not limited to) nuclear, biological or chemical weapons, or missiles capable of delivering such weapons.

#### Trademark Information

Silicon Laboratories Inc., Silicon Laboratories, Silicon Labs, SiLabs and the Silicon Labs logo, CMEMS®, EFM, EFM32, EFR, Energy Micro, Energy Micro logo and combinations thereof, "the world's most energy friendly microcontrollers", Ember®, EZLink®, EZMac®, EZRadio®, EZRadioPRO®, DSPLL®, ISOmodem®, Precision32®, ProSLIC®, SiPHY®, USBXpress® and others are trademarks or registered trademarks of Silicon Laboratories Inc. ARM, CORTEX, Cortex-M3 and THUMB are trademarks or registered trademarks of ARM Holdings. Keil is a registered trademark of ARM Limited. All other products or brand names mentioned herein are trademarks of their respective holders.



Silicon Laboratories Inc.  
400 West Cesar Chavez  
Austin, TX 78701  
USA

<http://www.silabs.com>