

## Dual N-Channel Enhancement-Mode MOSFET

### Product Summary

$V_{DS}$ (V)	$r_{DS(on)}$ ( $\Omega$ )	$I_D$ (A)
240	6 @ $V_{GS} = 10$ V	$\pm 0.4$
	8 @ $V_{GS} = 4.5$ V	$\pm 0.3$

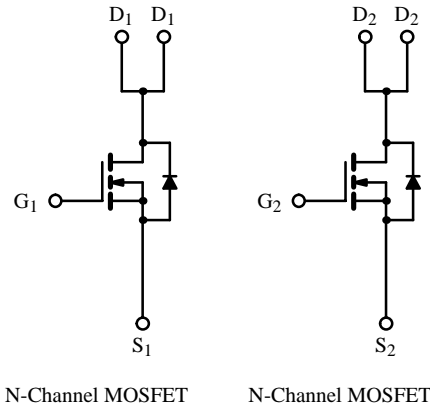
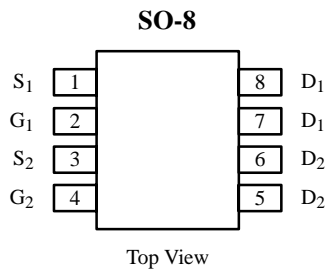

### Absolute Maximum Ratings ( $T_A = 25^\circ\text{C}$ Unless Otherwise Noted)

Parameter	Symbol	Limit	Unit
Drain-Source Voltage	$V_{DS}$	240	V
Gate-Source Voltage	$V_{GS}$	$\pm 20$	
Continuous Drain Current ( $T_J = 150^\circ\text{C}$ ) <sup>a</sup>	$I_D$	$T_A = 25^\circ\text{C}$	$\pm 0.4$
		$T_A = 70^\circ\text{C}$	$\pm 0.3$
Pulsed Drain Current	$I_{DM}$	$\pm 1.8$	A
Continuous Source Current (Diode Conduction) <sup>a</sup>	$I_S$	0.4	
Maximum Power Dissipation <sup>a</sup>	$P_D$	$T_A = 25^\circ\text{C}$	2
		$T_A = 70^\circ\text{C}$	1.3
Operating Junction and Storage Temperature Range	$T_J, T_{stg}$	-55 to 150	$^\circ\text{C}$

### Thermal Resistance Ratings

Parameter	Symbol	Limit	Unit
Maximum Junction-to-Ambient <sup>a</sup>	$R_{thJA}$	62.5	$^\circ\text{C}/\text{W}$

#### Notes

a. Surface Mounted on FR4 Board,  $t \leq 10$  sec.

Updates to this data sheet may be obtained via facsimile by calling Siliconix FaxBack, 1-408-970-5600. Please request FaxBack document #70132.

# Si9944DY

## Specifications ( $T_J = 25^\circ\text{C}$ Unless Otherwise Noted)

Parameter	Symbol	Test Condition	Min	Typ <sup>a</sup>	Max	Unit
<b>Static</b>						
Gate Threshold Voltage	$V_{GS(th)}$	$V_{DS} = V_{GS}, I_D = 250 \mu\text{A}$	0.5			V
Gate-Body Leakage	$I_{GSS}$	$V_{DS} = 0 \text{ V}, V_{GS} = \pm 20 \text{ V}$			$\pm 100$	nA
Zero Gate Voltage Drain Current	$I_{DSS}$	$V_{DS} = 190 \text{ V}, V_{GS} = 0 \text{ V}$			1	$\mu\text{A}$
		$V_{DS} = 190 \text{ V}, V_{GS} = 0 \text{ V}, T_J = 55^\circ\text{C}$			25	
On-State Drain Current <sup>b</sup>	$I_{D(on)}$	$V_{DS} \geq 25 \text{ V}, V_{GS} = 10 \text{ V}$	1.8			A
Drain-Source On-State Resistance <sup>b</sup>	$r_{DS(on)}$	$V_{GS} = 10 \text{ V}, I_D = 0.4 \text{ A}$		2.8	6	$\Omega$
		$V_{GS} = 4.5 \text{ V}, I_D = 0.3 \text{ A}$		3.1	8	
Forward Transconductance <sup>b</sup>	$g_{fs}$	$V_{DS} = 15 \text{ V}, I_D = 0.4 \text{ A}$		0.6		S
Diode Forward Voltage <sup>b</sup>	$V_{SD}$	$I_S = 0.4 \text{ A}, V_{GS} = 0 \text{ V}$		0.75	1.2	V
<b>Dynamic<sup>a</sup></b>						
Total Gate Charge	$Q_g$	$V_{DS} = 60 \text{ V}, V_{GS} = 10 \text{ V}, I_D = 0.4 \text{ A}$		4.6	6.0	nC
Gate-Source Charge	$Q_{gs}$			0.17		
Gate-Drain Charge	$Q_{gd}$			1.75		
Turn-On Delay Time	$t_{d(on)}$	$V_{DD} = 60 \text{ V}, R_L = 150 \Omega$ $I_D = 0.4 \text{ A}, V_{GEN} = 10 \text{ V}, R_G = 25 \Omega$		5	10	ns
Rise Time	$t_r$			5	10	
Turn-Off Delay Time	$t_{d(off)}$			20	30	
Fall Time	$t_f$			14	20	

### Notes

- Guaranteed by design, not subject to production testing.
- Pulse test; pulse width  $\leq 300 \mu\text{s}$ , duty cycle  $\leq 2\%$ .

## Typical Characteristics (25°C Unless Otherwise Noted)

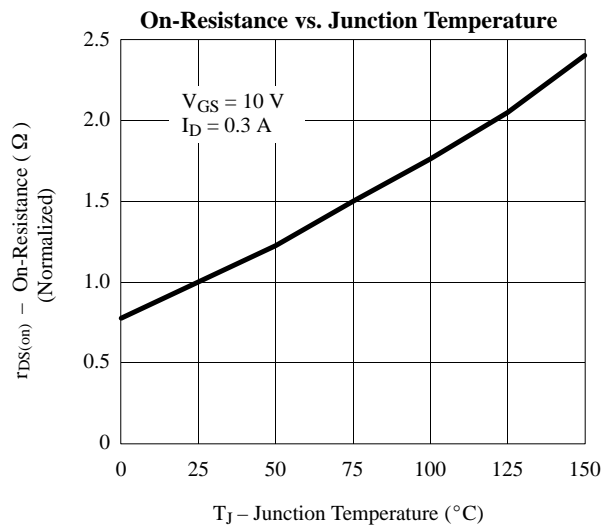
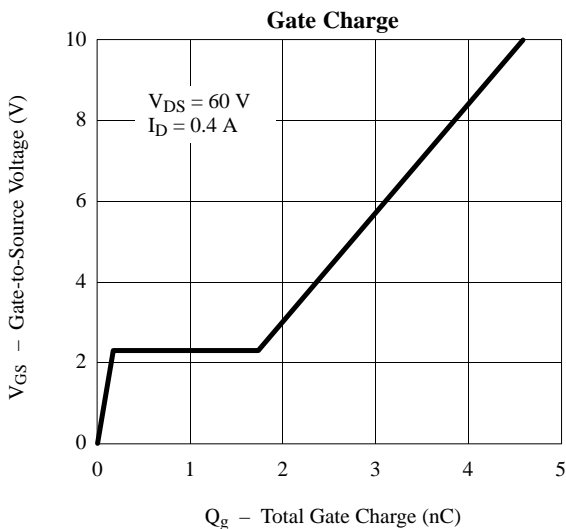
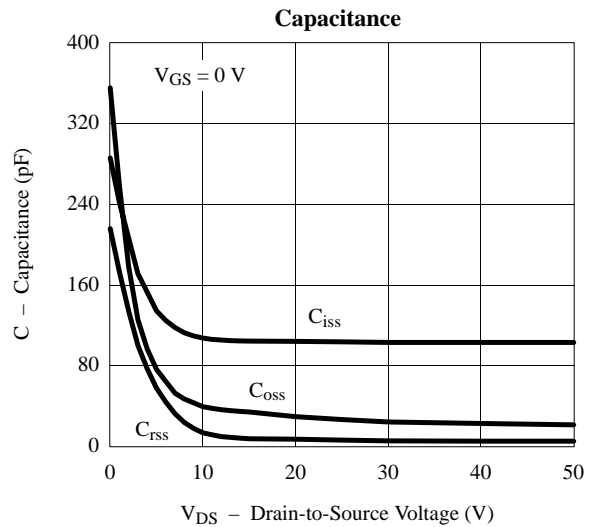
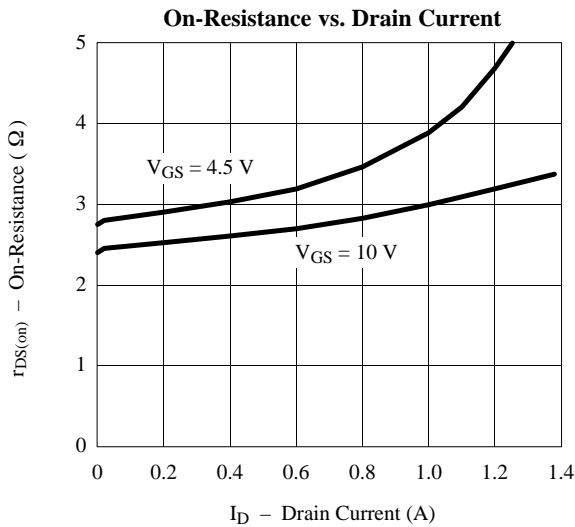
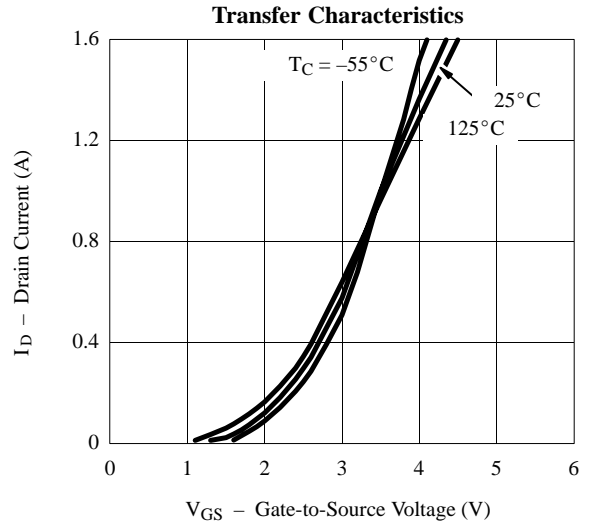
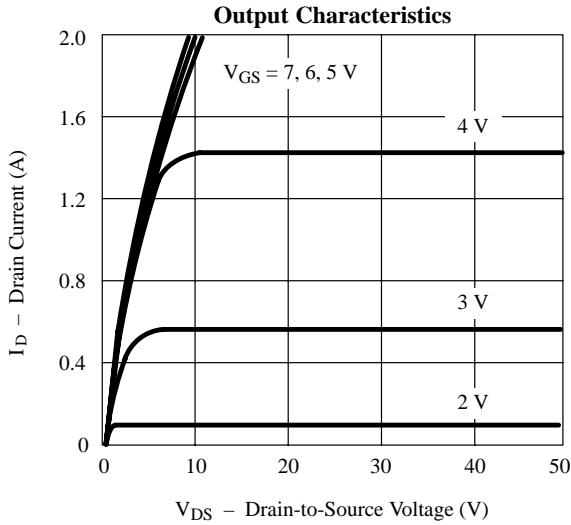

## Typical Characteristics (25°C Unless Otherwise Noted)

