

## High Performance Step-Down DC-DC Converter With Adjustable Output Voltage

### DESCRIPTION

The SiP12101 is a high efficiency 600 mA step down converter with internal low on resistance power MOSFET switch and synchronous rectifier transistors. It is designed to convert one cell Lilon battery or three cell alkaline battery voltages to an adjustable dc output. The integrated high frequency error amplifier with internal compensation minimizes external components.

2 MHz switching permits use of small external inductor and capacitor sizes allowing one of the smallest solutions.

The SiP12101 is available in the 10 pin MSOP and is specified to operate over the industrial temperature range of - 40 °C to 85 °C.

### FEATURES

- 2 MHz PWM operation
- Integrated MOSFET switches
- 2.6 V to 6.0 V input voltage range
- Minimal number of external components
- Up to 96 % conversion efficiency
- 600 mA load capability
- 100 % duty cycle allows low dropout
- Integrated compensation circuit
- Over-current protection
- Shutdown current < 2 mA
- Thermal shutdown
- Integrated UVLO
- 10 pin MSOP

### APPLICATIONS

- PDAs/palmtop PCs
- LCD podules
- Portable image scanners
- GPS receivers
- Smart phones
- MP3 players
- 3G cell phone
- Digital cameras

### TYPICAL APPLICATIONS CIRCUIT

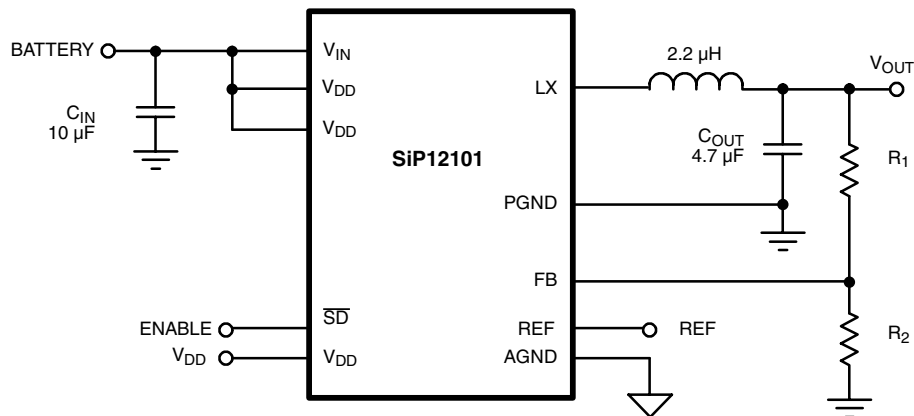

ABSOLUTE MAXIMUM RATINGS			
Parameter	Limit	Unit	
Voltages Referenced to AGND = 0 V			
$V_{IN}, V_{DD}$	6.2	V	
Lx, $\overline{SD}$ , FB, $C_{REF}$	- 0.3 to 6.2 (or to $V_{DD} + 0.3$ whichever is less)		
GND	- 0.3 to + 0.3		
ESD Rating	2	kV	
Storage Temperature	- 65 to 125	°C	
Operating Junction Temperature	150		
Power Dissipation (Package) <sup>a</sup>	10-pin MSOP <sup>b</sup>	481	mW
	10-pin MLP33	915	
Thermal Impedance ( $\Theta_{JA}$ )	10-Pin MSOP	135	°C/W
Peak Inductor Current	1.8	A	

## Notes:

a. Device mounted with all leads soldered or welded to PC board.

b. Derate 7.4 mW/°C above 85 °C.

c. Derate 14 mW/°C above 85 °C.

Stresses beyond those listed under "Absolute Maximum Ratings" may cause permanent damage to the device. These are stress ratings only, and functional operation of the device at these or any other conditions beyond those indicated in the operational sections of the specifications is not implied. Exposure to absolute maximum rating conditions for extended periods may affect device reliability.

RECOMMENDED OPERATING RANGE		
Parameter	Limit	Unit
$V_{IN}$ Range	2.6 to 5.5	V
$C_{IN}$	10 $\mu$ F ceramic	
$C_{OUT}$	4.7 $\mu$ F ceramic	
Inductor	2.2	$\mu$ H
Load Current	0 to 600	mA

SPECIFICATIONS							
Parameter	Symbol	Test Conditions Unless Specified - 40 °C to 85 °C, $V_{IN} = V_{DD}$ , $C_{IN} = 10 \mu$ F, $C_{OUT} = 4.7 \mu$ F $L = 2.2 \mu$ H, $2.6 \text{ V} \leq V_{IN} \leq 5.5 \text{ V}$ , $R_1 = 11.3 \text{ k}\Omega$ , $R_2 = 20 \text{ k}\Omega$	Limits			Unit	
			Min. <sup>a</sup>	Typ. <sup>b</sup>	Max. <sup>a</sup>		
<b>Under Voltage Lockout (UVLO)</b>							
Under Voltage Lockout (turn-on)		$V_{IN}$ rising	2.3		2.5	V	
Hysteresis				0.1			
<b>Shutdown (<math>\overline{SD}</math>)</b>							
Logic High	$V_{SDH}$		1.6			V	
Logic Low	$V_{SDL}$				0.4		
Delay to Output <sup>c</sup>	$t_{en}$	Settle within $\pm 2\%$ accuracy $\overline{SD}$ rising $t_r < 1 \mu$ s	$R_L = 3.3 \Omega$		100	$\mu$ s	
			$R_L = 51 \Omega$		100		
Pull Down	$I_{SD}$	Input at $V_{IN}$				$\mu$ A	
<b>Oscillator</b>							
Frequency	$f_{OSC}$		1.6	2	2.4	MHz	
<b>Error Amplifier (FB Pin)</b>							
FB Voltage Accuracy	$V_{FB}$		$T_A = 25 \text{ }^\circ\text{C}$	1.185	1.215	1.245	V
			$T_A = -40 \text{ }^\circ\text{C}$ to $85 \text{ }^\circ\text{C}$	1.170		1.260	
Power Supply Rejection	PSRR	$V_{IN} = 2.6 \text{ V}$ to $5.5 \text{ V}_{DC}$		60		db	
Input Bias Current	$I_{FB}$	$V_{FB} = 1.25 \text{ V}$	- 1	0.01	1	$\mu$ A	

SPECIFICATIONS						
Parameter	Symbol	Test Conditions Unless Specified - 40 °C to 85 °C, $V_{IN} = V_{DD}$ , $C_{IN} = 10 \mu F$ , $C_{OUT} = 4.7 \mu F$ $L = 2.2 \mu H$ , $2.6 V \leq V_{IN} \leq 5.5 V$ , $R_1 = 11.3 k\Omega$ , $R_2 = 20 k\Omega$	Limits			Unit
			Min. <sup>a</sup>	Typ. <sup>b</sup>	Max. <sup>a</sup>	
<b>Converter Operation</b>						
Maximum Output Current	$I_{LOAD}$	$V_{IN} = 3.6 V$	600			mA
Dropout Voltage <sup>e</sup>	$V_{DD}$	$V_{IN} = 2.6 V$ , $I_{OUT} = 600 mA$		190	300	mV
Closed Loop Bandwidth	BW			300		kHz
Load Regulation <sup>c</sup>		$V_{IN} = 3.6 V$ , $V_{OUT} = 1.9 V$ at 25 °C $I_{OUT} = 30 mA$ to 600 mA		0.5		%
Line Regulation		$V_{OUT} = 3.0 V$ , $V_{IN} = 3.5 V$ to 5.5 V		$\pm 0.1$		%/V
Maximum Inductor Peak Current Limit	$I_{Lpk}$			1500		mA
On Resistance - P-Channel and N-Channel	$R_{DS(on)}$	$V_{IN} = 3.6 V$		250		$m\Omega$
Output Ripple Voltage		$0.05 \Omega C_{OUT(ESR)}$	$I_{OUT} = 600 mA$	60		$mV_{p-p}$
Efficiency		$V_{IN} = 3.6 V$ , $V_{OUT} = 3.3 V$	$I_{OUT} = 600 mA$	90		%
Frequency		$I_{OUT} \geq 30 mA$	20			kHz
<b>Supply Current</b>						
Input Supply Current	$I_{SUPPLY}$ ( $V_{DD}$ & $V_{IN}$ )	$I_{OUT} = 0 mA$ , $V_{IN} = 3.6 V$ , (not switching, FB = GND)		450	750	$\mu A$
Shutdown Supply Current	$I_{SD}$	$\overline{SD} = Low$			2	
<b>Thermal Shutdown</b>						
Thermal Shutdown Temperature <sup>c</sup>	$T_{J(S/D)}$			165		°C
Thermal Hysteresis <sup>c</sup>				20		

Notes:

- a. The algebraic convention whereby the most negative value is a minimum and the most positive a maximum, is used in this data sheet.
- b. Typical values are for DESIGN AID ONLY, not guaranteed or subject to production testing.
- c. Guaranteed by design.
- d. Settling times,  $t_s$ , apply after  $t_{en}$ .
- e. Bypass is a device mode of operation, in which, the device is in 100 % duty cycle.

## PIN CONFIGURATION

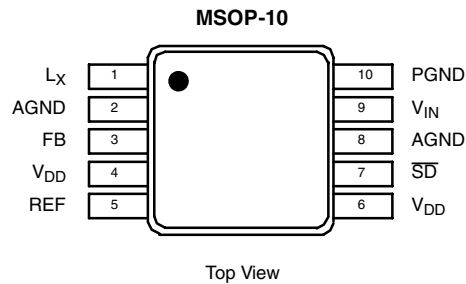

## PIN DESCRIPTION

Pin Number	Name	Function
1	$L_X$	Inductor connection
2	AGND	Low power analog ground
3	FB	Output voltage feedback
4	$V_{DD}$	Input supply voltage for the analog circuit.
5	REF	Internal reference, no connection should be made to this pin.
6	$V_{DD}$	Input supply voltage for the analog circuit.
7	$\overline{SD}$	Logic low disables IC and reduces quiescent current to below 2 $\mu$ A
8	AGND	Must be connected to AGND.
9	$V_{IN}$	Input supply voltage
10	PGND	Low impedance power ground

## ORDERING INFORMATION

Part Number	Marking	Temperature	Package
SiP12101DH-T1	2101	- 40 °C to 85 °C	MSOP-10

Additional voltage options are available.

Eval Kit	Temperature Range	Board
SiP12101DB	- 40 °C to 85 °C	Surface Mount

## FUNCTIONAL BLOCK DIAGRAM

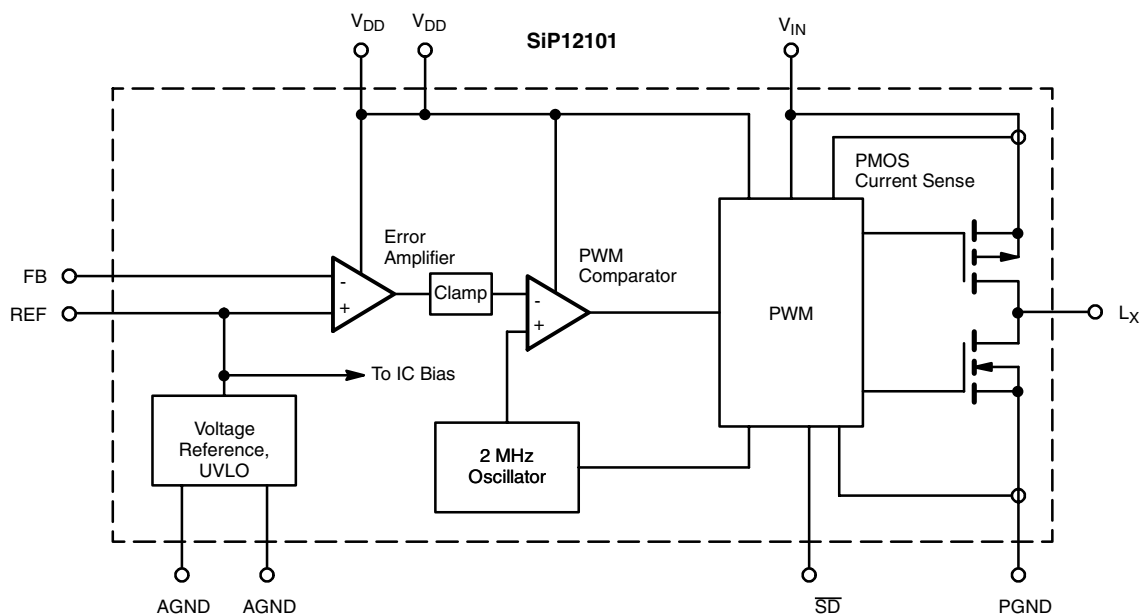

## DETAIL OPERATION

### General

The SiP12101 is a high efficiency synchronous dc-dc converter that is ideally suited for lithium ion battery or three cell alkaline applications, as well as step-down of 3.3 V or 5.0 V supplies. The major blocks of the SiP12101 are shown in the Functional Block Diagram. The 0.25  $\Omega$  internal MOSFETs switching at a frequency of 2 MHz minimize PC board space while providing high conversion efficiency and performance. The high frequency error-amplifier with built-in loop compensation minimizes external components and provides rapid output settling times of < 30  $\mu$ s. Sensing of the inductor current for control is accomplished internally without power wasting resistors.

### Start-Up

When voltage is applied to  $V_{IN}$  and  $V_{DD}$ , the under-voltage lockout (UVLO) circuit prevents the oscillator and control circuitry from turning on until the voltage on the exceeds 2.4 V. With a typical UVLO hysteresis of 0.1 V, the converter operates continuously until the voltage on  $V_{IN}$  drops below 2.3 V, whereupon the converter shuts down. This hysteresis prevents false start-stop cycling as the input voltage approaches the UVLO switching threshold. The start-up sequence occurs after  $\overline{SD}$  switches from LOW to HIGH with  $V_{IN}$  applied, or after  $V_{IN}$  rises above the UVLO threshold and  $\overline{SD}$  is a logic HIGH.

### PWM

SiP12101 operates as a 2 MHz fixed frequency voltage mode converter. An NMOS synchronous rectification MOSFET transistor provides very high conversion efficiency for large load currents by minimizing the conduction losses. Output load currents can range from 0 to 600 mA.

The error amplifier and comparator control the duty cycle of the PMOS MOSFET to continuously force the REF pin and FB pin voltages to be equal. As the input-to-output voltage difference drops, the duty cycle of the PMOS MOSFET can reach 100 % to allow system designers to extract the maximum stored energy from the battery. The dropout voltage is 190 mV at 600 mA.

During each cycle, the PMOS switch current is limited to a maximum of 1.5 A (typical) thereby protecting the IC while continuing to force maximum current into the load.

### Oscillator

The internal oscillator provides for a fixed 2 MHz switching frequency.

### Dynamic Output Voltage Control (REF)

The SiP12101 is designed with an adjustable output voltage which has a change of  $V_{FB}$  to  $V_{IN} - V_{DROP}$ .  $V_{OUT}$  is defined according to the following relationship:

$$V_{OUT} = \left( 1 + \frac{R_1}{R_2} \right) \times V_{FB}$$

### Converter Shutdown ( $\overline{SD}$ pin)

With logic LOW level on the  $\overline{SD}$  pin, the SiP12101 is shutdown. Shutdown reduces current consumption to less than 2  $\mu$ A by shutting off all of the internal circuits. Both the PMOS and NMOS transistors are turned off. A logic HIGH enables the IC to start up as described in "Start-up" section.

### Thermal Shutdown

The SiP12101 includes thermal shutdown circuitry, which turns off the regulator when the junction temperature exceeds 165  $^{\circ}$ C. Once the junction temperature drops below 145  $^{\circ}$ C, the regulator is enabled. If the condition causing the over temperature, the SiP12101 begins thermal cycling, turning the regulator on and off in response to junction temperature. Restart from a thermal shutdown condition is the same as described in the "Start-up" section.

## APPLICATIONS CIRCUIT

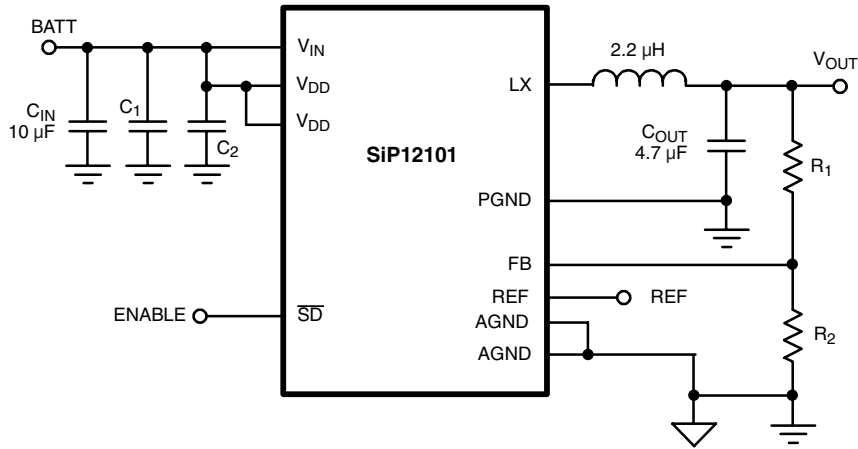

$C_{IN} = 10 \mu\text{F}$ , Ceramic, Murata GRM42-2X5R106K16  
 $C_1, C_2 = 0.01 \mu\text{F}$ , Vishay VJ0603Y 104KXXAT  
 $C_{OUT} = 4.7 \mu\text{F}$ , Ceramic, Murata GRM42-6X5R475K16  
 $R_1 = 8.2 \text{ k}\Omega$ , Vishay CRCW06031132F  
 $R_2 = 20 \text{ k}\Omega$ , Vishay CRCW06032002F  
 $L_1 = 2.2 \mu\text{H}$ , Toko A914BYW-2R2M

**TYPICAL CHARACTERISTICS**

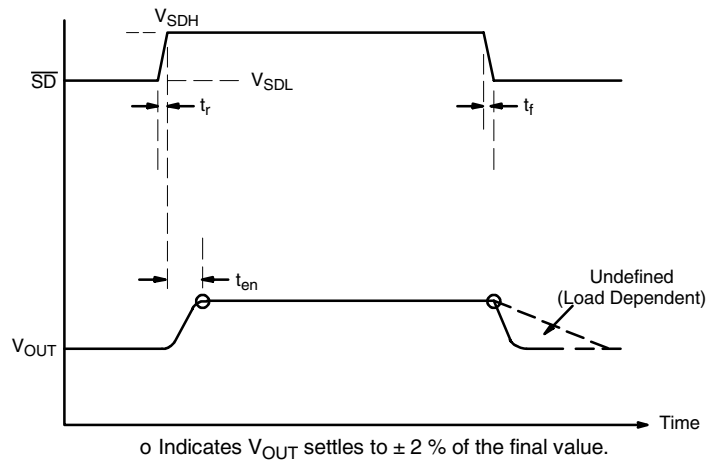

**Figure 1. PWM Mode  $V_{OUT}$  Settling**

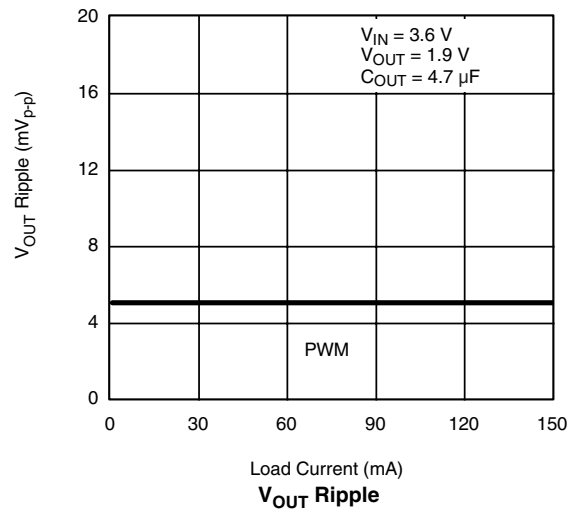
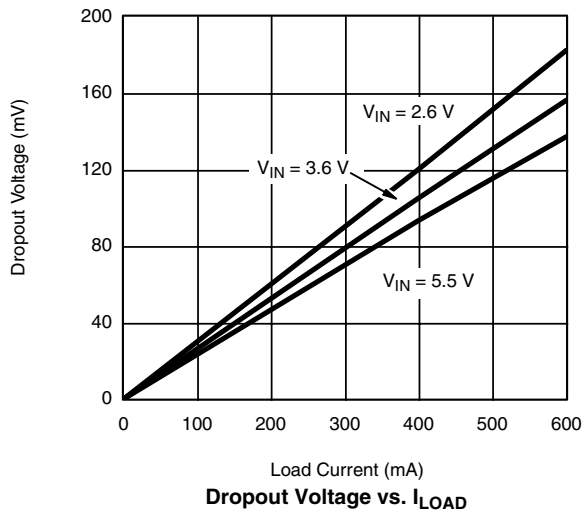

## TYPICAL SWITCHING WAVEFORMS ( $V_{IN} = 3.6\text{ V}$ , $V_{OUT} = 3.0\text{ V}$ )

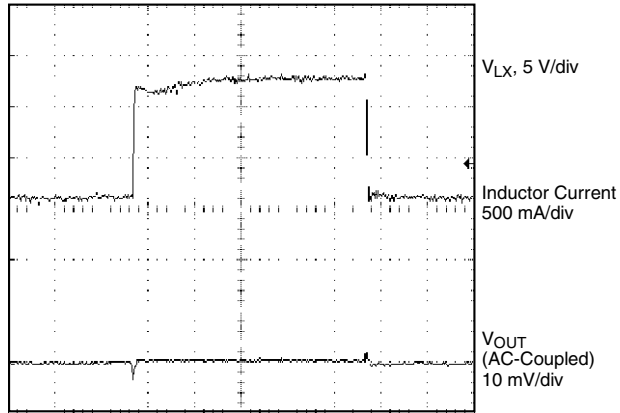

**Heavy-Load Switching Waveforms**  
 $I_{OUT} = 600\text{ mA}$

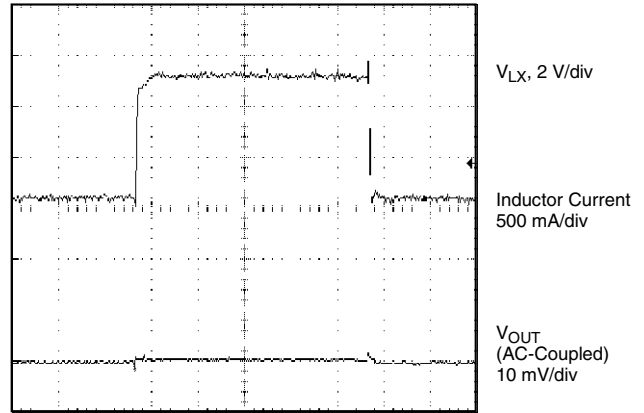

**Medium-Load Switching Waveforms**  
 $I_{OUT} = 300\text{ mA}$

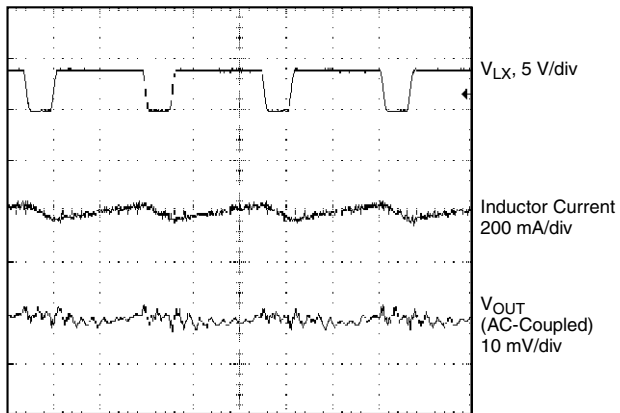

**Light-Load Switching Waveforms**  
 $I_{OUT} = 0\text{ mA}$



**TYPICAL SWITCHING WAVEFORMS** ( $V_{IN} = 3.6\text{ V}$ ,  $V_{OUT} = 1.9\text{ V}$ )

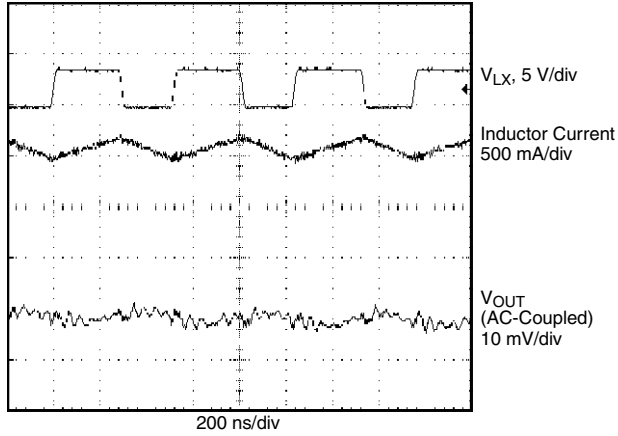

**Heavy-Load Switching Waveforms**  
 $I_{OUT} = 600\text{ mA}$

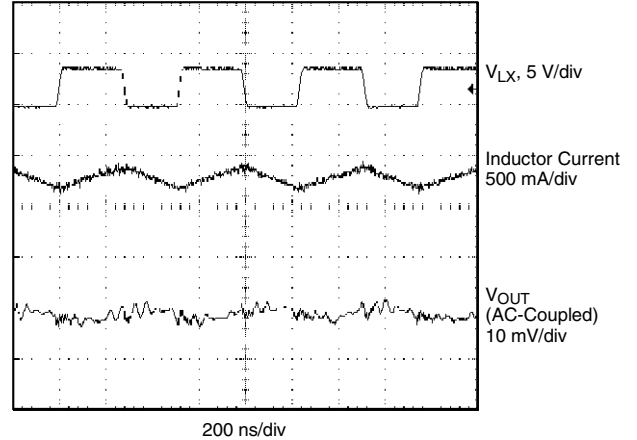

**Medium-Load Switching Waveforms**  
 $I_{OUT} = 300\text{ mA}$

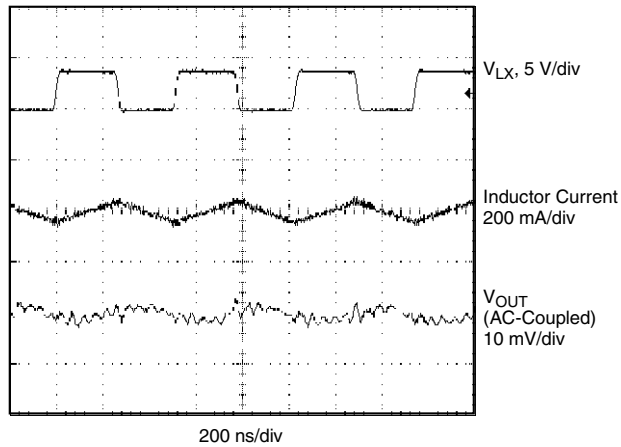

**Light-Load Switching Waveforms**  
 $I_{OUT} = 0\text{ mA}$

## TYPICAL START-UP AND SHUTDOWN TRANSIENT WAVEFORMS ( $V_{IN} = 3.6\text{ V}$ , $V_{OUT} = 1.9\text{ V}$ )

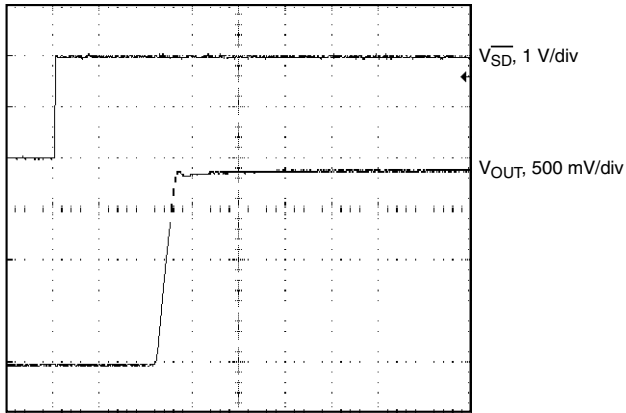

20  $\mu\text{s}/\text{div}$   
Start-Up,  $R_{LOAD} = 4\ \Omega$

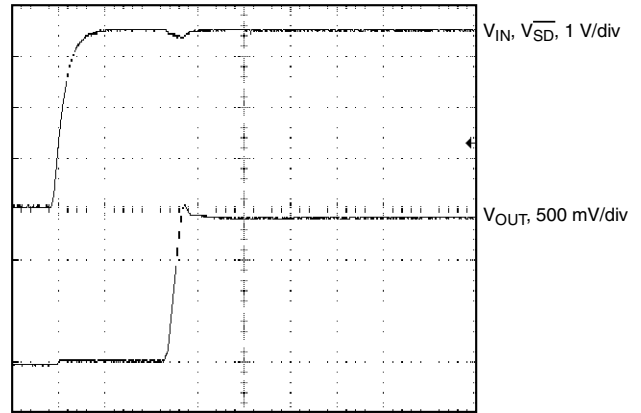

20  $\mu\text{s}/\text{div}$   
Start-Up,  $V_{IN} = V_{SD} = 3.6\text{ V}$ ,  $R_{LOAD} = 4\ \Omega$

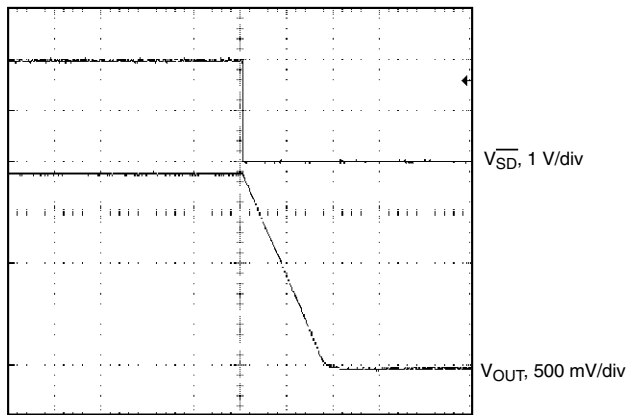

200  $\mu\text{s}/\text{div}$   
Shutdown,  $R_{LOAD} = 4\ \Omega$

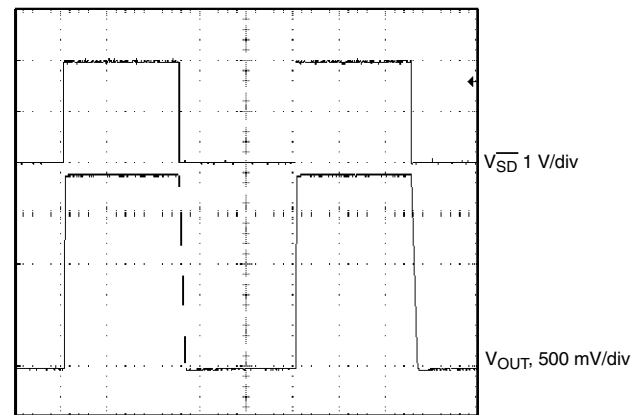

20  $\mu\text{s}/\text{div}$   
Enable Switching,  $R_{LOAD} = 4\ \Omega$

**TYPICAL LOAD TRANSIENT WAVEFORMS** ( $V_{IN} = 3.6\text{ V}$ ,  $V_{OUT} = 1.9\text{ V}$ )

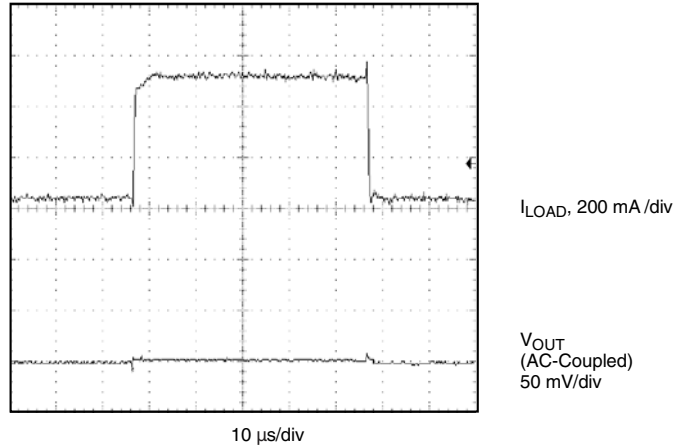

**Load Transient**  
 $I_{LOAD} = 30\text{ to }500\text{ mA}$ ,  $L = 2.2\text{ }\mu\text{H}$

Vishay Siliconix maintains worldwide manufacturing capability. Products may be manufactured at one of several qualified locations. Reliability data for Silicon Technology and Package Reliability represent a composite of all qualified locations. For related documents such as package/tape drawings, part marking, and reliability data, see [www.vishay.com/ppg?73057](http://www.vishay.com/ppg?73057).



**MSOP: 10-LEADS (POWER IC ONLY)**

JEDEC Part Number: MO-187, (Variation AA and BA)

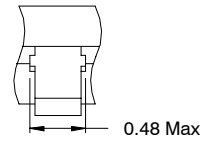
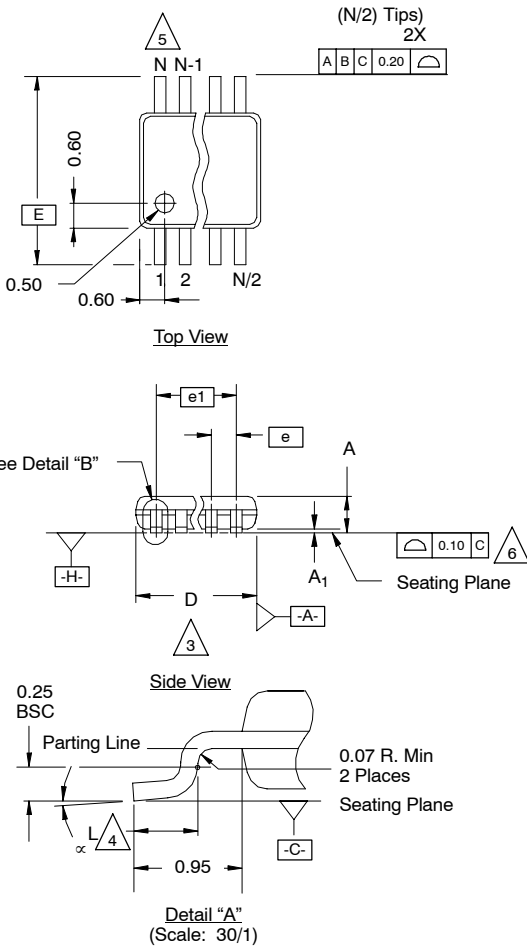

Detail "B"  
(Scale: 30/1)  
Dambar Protrusion

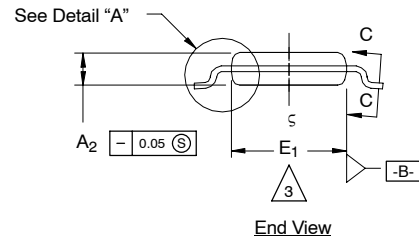
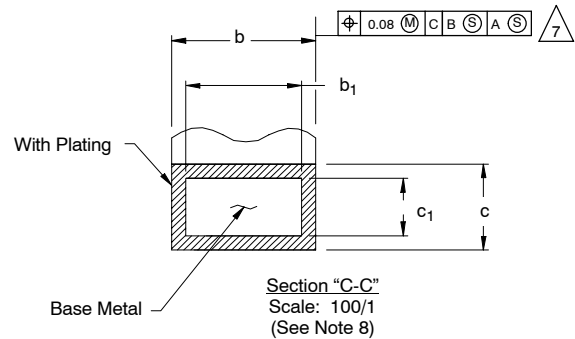

NOTES:

- Die thickness allowable is  $0.203 \pm 0.0127$ .
- Dimensioning and tolerances per ANSI.Y14.5M-1994.
- Dimensions "D" and "E<sub>1</sub>" do not include mold flash or protrusions, and are measured at Datum plane  $\square\text{-H}\square$ , mold flash or protrusions shall not exceed 0.15 mm per side.
- Dimension is the length of terminal for soldering to a substrate.
- Terminal positions are shown for reference only.
- Formed leads shall be planar with respect to one another within 0.10 mm at seating plane.
- The lead width dimension does not include Dambar protrusion. Allowable Dambar protrusion shall be 0.08 mm total in excess of the lead width dimension at maximum material condition. Dambar cannot be located on the lower radius or the lead foot. Minimum space between protrusions and an adjacent lead to be 0.14 mm. See detail "B" and Section "C-C".
- Section "C-C" to be determined at 0.10 mm to 0.25 mm from the lead tip.
- Controlling dimension: millimeters.
- This part is compliant with JEDEC registration MO-187, variation AA and BA.
- Datums  $\square\text{-A}\square$  and  $\square\text{-B}\square$  to be determined Datum plane  $\square\text{-H}\square$ .
- Exposed pad area in bottom side is the same as teh leadframe pad size.

**N = 10L**

Dim	MILLIMETERS			Note
	Min	Nom	Max	
A	-	-	1.10	
A <sub>1</sub>	0.05	0.10	0.15	
A <sub>2</sub>	0.75	0.85	0.95	
b	0.17	-	0.27	8
b <sub>1</sub>	0.17	0.20	0.23	8
c	0.13	-	0.23	
c <sub>1</sub>	0.13	0.15	0.18	
D	3.00 BSC			3
E	4.90 BSC			
E <sub>1</sub>	2.90	3.00	3.10	3
e	0.50 BSC			
e <sub>1</sub>	2.00 BSC			
L	0.40	0.55	0.70	4
N	10			5
α	0°	4°	6°	
ECN: S-40082—Rev. A, 02-Feb-04 DWG: 5922				



## Disclaimer

ALL PRODUCT, PRODUCT SPECIFICATIONS AND DATA ARE SUBJECT TO CHANGE WITHOUT NOTICE TO IMPROVE RELIABILITY, FUNCTION OR DESIGN OR OTHERWISE.

Vishay Intertechnology, Inc., its affiliates, agents, and employees, and all persons acting on its or their behalf (collectively, "Vishay"), disclaim any and all liability for any errors, inaccuracies or incompleteness contained in any datasheet or in any other disclosure relating to any product.

Vishay makes no warranty, representation or guarantee regarding the suitability of the products for any particular purpose or the continuing production of any product. To the maximum extent permitted by applicable law, Vishay disclaims (i) any and all liability arising out of the application or use of any product, (ii) any and all liability, including without limitation special, consequential or incidental damages, and (iii) any and all implied warranties, including warranties of fitness for particular purpose, non-infringement and merchantability.

Statements regarding the suitability of products for certain types of applications are based on Vishay's knowledge of typical requirements that are often placed on Vishay products in generic applications. Such statements are not binding statements about the suitability of products for a particular application. It is the customer's responsibility to validate that a particular product with the properties described in the product specification is suitable for use in a particular application. Parameters provided in datasheets and/or specifications may vary in different applications and performance may vary over time. All operating parameters, including typical parameters, must be validated for each customer application by the customer's technical experts. Product specifications do not expand or otherwise modify Vishay's terms and conditions of purchase, including but not limited to the warranty expressed therein.

Except as expressly indicated in writing, Vishay products are not designed for use in medical, life-saving, or life-sustaining applications or for any other application in which the failure of the Vishay product could result in personal injury or death. Customers using or selling Vishay products not expressly indicated for use in such applications do so at their own risk and agree to fully indemnify and hold Vishay and its distributors harmless from and against any and all claims, liabilities, expenses and damages arising or resulting in connection with such use or sale, including attorneys fees, even if such claim alleges that Vishay or its distributor was negligent regarding the design or manufacture of the part. Please contact authorized Vishay personnel to obtain written terms and conditions regarding products designed for such applications.

No license, express or implied, by estoppel or otherwise, to any intellectual property rights is granted by this document or by any conduct of Vishay. Product names and markings noted herein may be trademarks of their respective owners.