

Features

- Factory programmable from 32.768 kHz down to 1 Hz
- Supply voltage optimized for Li+ battery voltage: 2.7V to 4.3V
- Smallest footprint in chip-scale (CSP): 1.5 x 0.8 mm
- Pin-compatible 2.0 x 1.2 mm XTAL SMD package
- Ultra-low power: 750 nA (typ)
- Oscillator output eliminates external load caps
- NanoDrive™ programmable output swing for lowest power
- Internal filtering eliminates external Vdd bypass cap
- <20 PPM initial stability
- <100 PPM stability over -40°C to +85°C
- Pb-free, RoHS and REACH compliant

Applications

- Wireless Mouse or Trackball
- Wireless Keypads
- Pulse-per-Second (pps) Timekeeping
- RTC Reference Clock
- Battery Management Timekeeping

EXPRESS
SAMPLESGREEN
SOLUTIONSQUARTZ
FREE

Electrical Characteristics

Parameter	Symbol	Min.	Typ.	Max.	Unit	Condition
Frequency and Stability						
Programmable Output Frequency		1.00		32768.0	Hz	Factory programmed between 1 and 32.768 kHz in powers of 2
Frequency Stability						
Frequency Stability ⁽¹⁾	F_stab			20	PPM	T _A = 25°C, Vdd: 3.0V – 4.3V
				75		T _A = -10°C to +70°C, Vdd: 3.0V – 4.3V. Stability includes initial, power supply, and temperature stability components.
				100		T _A = -40°C to +85°C, Vdd: 3.0V – 4.3V. Stability includes initial, power supply, and temperature stability components.
				175		T _A = -40°C to +85°C, Vdd: 2.7V – 3.0V. Stability includes initial, power supply, and temperature stability components.
25°C Aging		-3		3	PPM	1st Year
Supply Voltage and Current Consumption						
Operating Supply Voltage	Vdd	2.7		4.3	V	T _A = -40°C to +85°C
		2.7		4.5	V	T _A = -10°C to +70°C
Power Supply Reset Voltage	Reset		0.3		V	
Core Operating Current ^(2, 3)	Idd		0.90		µA	T _A = 25°C, Vdd: 3.0V – 4.3V. No Load
			0.75	TBD		T _A = -10°C to +70°C, Vdd max: 4.3V. No Load
				TBD		T _A = -40°C to +85°C, Vdd max: 4.3V. No Load
Output Stage Operating Current ⁽³⁾	Idd_out		0.165		µA/Vpp	T _A = 25°C, Vdd: 3.0V – 4.3V No Load
T _{START-UP} at Power-up	T_start		150	TBD	ms	T _A = 25°C
Operating Temperature Range						
Commercial Temperature	T_use	-10		70	°C	
Industrial Temperature		-40		85	°C	
Rail-to-Rail Output Option						
Output Rise/Fall Time	tr, tf			200	ns	10-90%, 15 pF Load.
Output Clock Duty Cycle	DC	45		55	%	LVC MOS Output
Output Voltage High	VOH	Vdd - 1.54			V	Vdd: 2.7V – 4.3V. I _{OH} = -10 µA
Output Voltage Low	VOL			50	mV	Vdd: 2.7V – 4.3V I _{OL} = 10 µA
NanoDrive™ Programmable, Reduced Swing Output						
Reduced Swing Output	V_sw	0.25		0.80	V	Vdd: 2.7V – 4.3V. For AC-coupled receiver
Output Voltage High Range	VOH	0.50		1.20	V	15 pF, I _{OH} = -0.2µA
Output Voltage Low Range	VOL	0.25		0.80	V	15 pF, I _{OL} = 0.2µA
Output Rise/Fall Time	tr, tf		80	TBD	ns	
Output Clock Duty Cycle	DC	45		55	%	
Jitter Performance (T_A = 25°C, Vdd = 3.0V to 4.3V, unless otherwise stated)						
Period Jitter	T_djitt		45		nSRMS	N = 10,000

Notes:

1. Stability is specified for two operating voltage ranges. Stability progressively degrades with supply voltage below 3.0V.
2. Core operating current does not include output driver operating current or load current.
3. To derive total operating current (no load), add core operating current + (0.165 µA/V) * (peak-to-peak output voltage swing).

SiT1544

Smallest Footprint (1.2mm²), Ultra-Low Power 1 Hz - 32.768 kHz Programmable Oscillator for Li+ Unregulated Battery Powered Applications



Pin Configuration (SMD)

Pin	Symbol	I/O	Functionality
1	NC (X OUT)	No Connect, don't care	No Connect. Will not respond to any input signal. When the SiT1544 is used as an alternative to an XTAL, this pin is typically connected to the receiving ICs X Out pin. In this case, the SiT1544 will not be affected by the signal on this pin.
2	GND	Power Supply Ground	Connect to ground.
3	CLK Out (X IN)	OUT	Oscillator clock output. When the SiT1544 is used as an alternative to an XTAL, the CLK Out is typically connected to the receiving ICs X IN pin. No need for load capacitors. The output driver is independent of capacitive loading.
4	Vdd	Power Supply	Connect to power supply $2.7V \leq Vdd \leq 4.5V$. Under normal operating conditions, Vdd does not require external bypass/decoupling capacitor(s). Contact factory for applications that require a wider operating supply voltage range.

SMD Package (Top View)

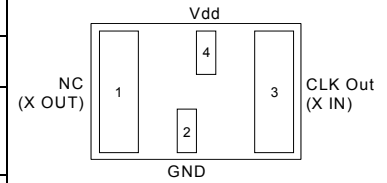

Pin Configuration (CSP)

Pin	Symbol	I/O	Functionality
1, 4	GND	Power Supply Ground	Connect to ground. Acceptable to connect pin 1 and 4 together.
2	CLK Out	OUT	Oscillator clock output. The CLK can drive into a Ref CLK input or into an ASIC or chip-set's 32kHz XTAL input. When driving into an ASIC or chip-set oscillator input (X IN and X Out), the CLK Out is typically connected directly to the XTAL IN pin. No need for load capacitors. The output driver is relatively sensitive to capacitive loading. The maximum output voltage is internally limited to 2.1V.
3	Vdd	Power Supply	Connect to power supply $2.7V \leq Vdd \leq 4.5V$. Under normal operating conditions, Vdd does not require external bypass/decoupling capacitor(s). Contact factory for applications that require a wider operating supply voltage range.

CSP Package (Top View)

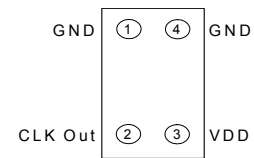

System Block Diagram

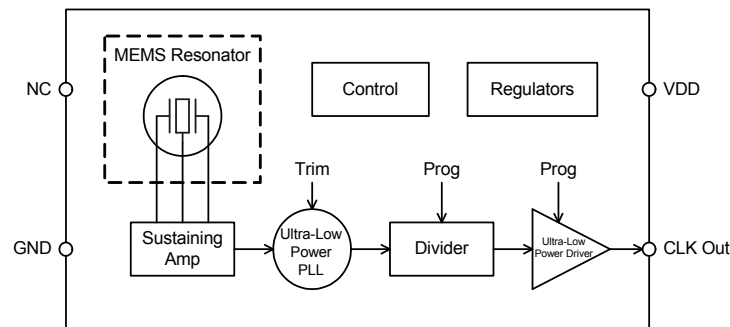

Figure 1.

SiT1544

Smallest Footprint (1.2mm²), Ultra-Low Power 1 Hz - 32.768 kHz
Programmable Oscillator for Li+ Unregulated Battery Powered Applications



The Smart Timing Choice™

Absolute Maximum

Attempted operation outside the absolute maximum ratings of the part may cause permanent damage to the part. Actual performance of the IC is only guaranteed within the operational specifications, not at absolute maximum ratings.

Parameter	Symbol	Test Condition	Value	Unit
Power Supply Voltage Range (Vdd)	Vdd		-0.5 to 4	V
ESD Protection		HBM 100pF, 1.5kΩ	2000	V
ESD Protection		CDM, 25°C	750	V
ESD Protection		MM, 25°C	200	V
Latch-up Tolerance			JESD78 Compliant	
Mechanical Shock Resistance	ΔF/F	Mil 883, Method 2002	50,000	g
Mechanical Vibration Resistance	ΔF/F	Mil 883, Method 2005	70	g
2012 DFN Junction Temperature			TBD	
CSP Junction Temperature			TBD	
Storage Temperature			-65°C to 150°C	

Thermal Consideration

Package	θJA, 4 Layer Board (°C/W)	θJA, 2 Layer Board (°C/W)	θJC, Bottom (°C/W)
2012 SMD	TBD		
1508 CSP	TBD		

SiT1544

Smallest Footprint (1.2mm²), Ultra-Low Power 1 Hz - 32.768 kHz Programmable Oscillator for Li+ Unregulated Battery Powered Applications



Description

The SiT1544 is the first programmable oscillator capable of a frequency range between 32.768 kHz down to 1 Hz for true pulse-per-second (PPS) operation. The SiT1544 is the world's smallest, lowest power 32 kHz oscillator optimized for unregulated Li+ battery powered applications where the supply voltage must track the Li+ battery voltage from 4.3V down to 2.7V. SiTime's silicon MEMS technology enables the smallest footprint and chip-scale packaging. In the chip-scale package (CSP), these devices reduce footprint by as much as 80% compared to existing 2.0 x 1.2 mm SMD XTAL packages. Unlike XTALs, the SiT1544 oscillator output enables greater component placement flexibility and eliminates external load capacitors, thus saving additional component count and board space. And unlike standard oscillators, the SiT1544 features NanoDrive™, a factory programmable output that reduces the voltage swing to minimize power.

XTAL Footprint Compatibility (SMD Package)

For applications that require XTAL resonator compatibility, the SiT1544 is available in the 2.0 x 1.2 mm (2012) package. SiTime's silicon MEMS oscillators require a power supply (Vdd) and ground (GND) pin. Vdd and GND pins are conveniently placed between the two large XTAL pins. When using the SiTime Solder Pad Layout (SPL), the SiT1544 footprint is compatible with existing 32 kHz XTALs in the 2012 SMD package. Figure 2 shows the comparison between the quartz XTAL footprint and the SiTime footprint.

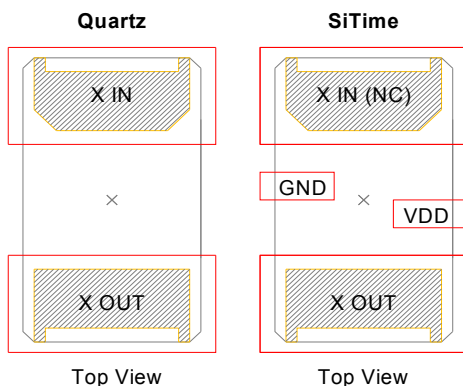

Figure 2. SiT1544 Footprint Compatibility with Quartz XTAL Footprint ⁽⁴⁾

Frequency Stability

The SiT1544 is factory calibrated (trimmed) to guarantee frequency stability to be less than 20 PPM at room temperature and less than 100 PPM over the full -40°C to +85°C temperature range. Unlike quartz crystals that have a classic tuning fork parabola temperature curve with a 25°C turnover point, the SiT1544 temperature coefficient is extremely flat across temperature. The device maintains less than 100 PPM frequency stability over the full operating temperature range when the operating voltage is between 3.0V and 4.3V, and 150 PPM frequency stability for low-voltage operation down to 2.7V.

Power Supply Noise Immunity

In addition to eliminating external output load capacitors common with standard XTALs, this device includes special power supply filtering and thus, eliminates the need for an external Vdd bypass-decoupling capacitor. This feature further simplifies the design and keeps the footprint as small as possible. Internal power supply filtering is designed to reject noise up to ±50 mVpp through 5 MHz.

Programmable Frequency

The SiT1544 is the first oscillator to feature a programmable frequency range between 1 Hz and 32.768 kHz in powers of two. Reducing the frequency significantly reduces the output load current (C*V*F). For example, reducing the frequency from 32.768 kHz to 10 kHz improves load current by 70%. Similarly, reducing the output frequency from 32.768 kHz down to 1Hz reduces the load current by more than 99%.

The part number ordering shows the specific frequency options.

Output Voltage

For low-power applications that drive directly into a chip-set's XTAL input the reduced swing output is ideal. SiTime's unique NanoDrive™, factory-programmable output stage is optimized for low voltage swing to minimize power and maintain compatibility with the downstream oscillator input. The SiT1544 output swing is factory programmed between 250 mVpp and 800 mVpp. For DC-coupled applications, output V_{OH} and V_{OL} are individually factory programmed to the customers' requirement. V_{OH} programming range is between 500 mV and 1.2V in 100 mV increments. Similarly, V_{OL} programming range is between 250 mV and 800 mV. See the part numbering ordering information and examples for details.

Note:

4. On the SiTme device, X IN is not internally connected and will not respond to any signal. It is acceptable to connect to chipset X OUT.

Calculating Load Current

No Load Supply Current

When calculating no-load power for the SiT1544, the core and output driver components need to be added. Since the output voltage swing can be programmed for reduced swing between 250 mV and 800 mV, the output driver current is variable. Therefore, no-load operating supply current is broken into two sections; core and output driver.

The examples below illustrate the low-power benefits the NanoDrive reduced swing output. For example, no load current is improved by 12% when compared to an LVCMOS (2.1V) swing. The benefit from the load current savings is even greater, as shown in the total current calculation examples.

The equation is as follows:

Total Supply Current (no load) = I_{dd} Core + I_{dd} Output Stage

Where,

- I_{dd} Core = 750nA
- I_{dd} Output Stage = (3.5pF)(V_{out})(F_{out})
- For NanoDrive reduced swing, select the output voltage swing, or V_{OH}/V_{OL}, as shown in the datasheet ordering section.

Example 1: Full-swing LVCMOS

- V_{dd} = 3.3V (Avg)
- F_{out} = 32.768 kHz
- V_{out} = 2.1V (max output of device)
- I_{dd} Core = 750nA
- I_{dd} Output Stage = (3.5pF)(2.1V)(32.768kHz) = 241nA

No Load Supply Current = 750nA + 241nA = 991nA

Example 2: NanoDrive™ Reduced Swing

- V_{dd} = 3.3V (Avg)
- F_{out} = 32.768 kHz
- NanoDrive™ Output Selection:
 - V_{out} = V_{oh} – V_{ol} = 0.6V
 - Where, V_{oh} = 1.1V, V_{ol} = 0.6V
- I_{dd} Core = 800nA
- I_{dd} Output Stage = (3.5pF)(0.5V)(32.768kHz) = 57nA

No Load Supply Current with NanoDrive = 800nA + 57nA = 857nA

Total Supply Current with Load

To calculate the total supply current, including the load, follow the equation listed below. The additional load current comes from a combination of the load capacitance, output voltage, and frequency (C*V*F). Since the SiT1544 includes the NanoDrive reduced swing output and a selectable output frequency down to 1 Hz, these two variables will significantly improve load current.

The benefits of NanoDrive really become significant when the load current is considered. Note the greater than 40% reduction in power with NanoDrive™ as shown in Example 2. Reducing the output clock frequency reduces the load current significantly, as shown in Example 3.

Total Current = I_{dd} Core + I_{dd} Output Driver + Load Current

Where,

- I_{dd} Core = 750nA (LVCMOS Output) or 800nA (NanoDrive™ Output)
- I_{dd} Output Stage = (3.5pF)(V_{out})(F_{out})
- I_{dd} Load = (C_{load})(V_{out})(F_{out})
- Assume load capacitance is 10pF

Example 1: Full-swing LVCMOS

- V_{dd} = 3.0V (Avg)
- F_{out} = 32.768 kHz
- V_{out_{pp}} = 2.1V (max output swing for this device)
- I_{dd} Core = 750nA
- I_{dd} Output Driver: (3.5pF)(2.1V)(32.768) = 241nA
- Load Current: (10pF)(2.1V)(32.768kHz) = 688nA

Total Current with Load = 750nA + 241nA + 688nA = 1.68μA

Example 2: NanoDrive™ Reduced Swing

- V_{dd} = 3.0V (Avg)
- F_{out} = 32.768 kHz
- NanoDrive Output Selection:
 - V_{out_{pp}} = V_{oh} – V_{ol} = 0.5V
 - Where, V_{oh} = 1.1V, V_{ol} = 0.6V

- I_{dd} Core = 800nA
- I_{dd} Output Stage = (3.5pF)(0.5V)(32.768kHz) = 57nA
- Load Current: (10pF)(0.5V)(32.768kHz) = 164nA

Total Current with Load = 800nA + 57nA + 164nA = 1.02μA

Example 3: NanoDrive™ Reduced Swing and 1Hz Output Frequency

- Same conditions as above example 2, but with output frequency = 1 Hz. This will significantly reduce the current consumption from the output stage and the load.

- I_{dd} Core = 800nA
- I_{dd} Output Stage = (3.5pF)(0.5V)(1Hz) = 1.75pA
- 1Hz Output Frequency impacts the load current as shown below:

$$\text{Load Current} = (\text{Cload})(\text{Vout})(\text{Fout}) = (10\text{pF})(0.5\text{V})(1\text{Hz}) = 5\text{pA}$$

Total Supply Current with Load = Core Current + Output Stage Current + Load Current = 800nA + 0.00175nA + 0.005nA = 800nA

Summary: Reducing the output frequency to 1 Hz effectively eliminates the current consumption from the output stage and load current.

SiT1544

Smallest Footprint (1.2mm²), Ultra-Low Power 1 Hz - 32.768 kHz
Programmable Oscillator for Li+ Unregulated Battery Powered Applications



The Smart Timing Choice™

Dimensions and Patterns

Package Size – Dimensions (Unit: mm)	Recommended Land Pattern (Unit: mm)
<p>2.0 x 1.2 mm SMD</p> <p>2.0±0.05 1.20±0.05 0.55±0.05 R0.1</p>	<p>SiTime Only SPL</p> <p>XTAL Compatible SPL</p>
<p>1.5 x 0.8 mm CSP</p> <p>1.56 MAX 0.86 MAX 0.55 MAX 0.41 BSC 1.00 BSC</p>	<p>Soldermask cleared underneath part Pins 1, 4 shorted 0.41 0.83 1.00 0.60 0.25 (4x) NSMD pads 0.35 (4x)</p> <p>(soldermask opening shown as heavy dashed line)</p>

SiT1544

Smallest Footprint (1.2mm²), Ultra-Low Power 1 Hz - 32.768 kHz
Programmable Oscillator for Li+ Unregulated Battery Powered Applications



The Smart Timing Choice™

Ordering Information

Part number characters in blue represent the customer specific options. The other characters in the part number are fixed.

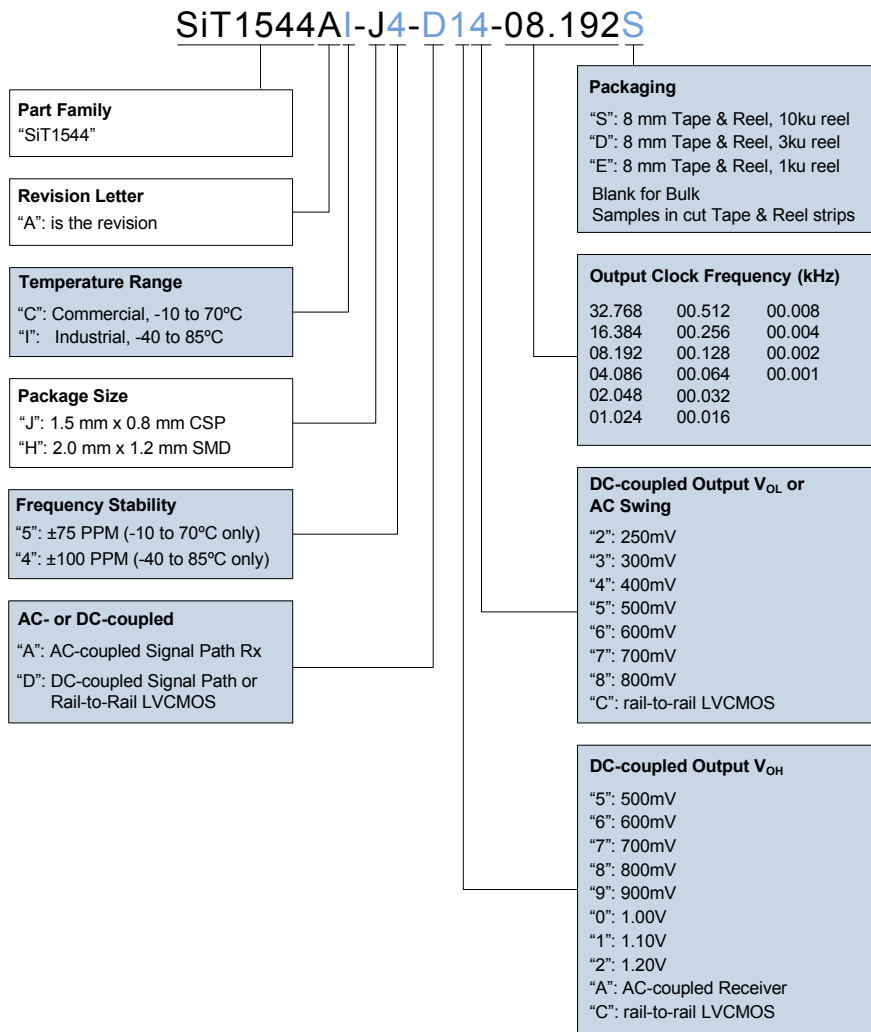

The following examples illustrate how to select the appropriate temp range and output voltage requirements:

Example 1: SiT1544AI-J4-D14-08.192

- Industrial temp & corresponding 100 PPM frequency stability
- Output swing requirements:
 - a) Output frequency = 8.192 kHz
 - b) "D" = DC-coupled receiver
 - c) "1" = V_{OH} = 1.1V
 - d) "4" = V_{OL} = 0.4V

Example 2: SiT1544AC-J5-AA5-00.001

- Commercial temp & corresponding 75 PPM frequency stability
- Output swing requirements:
 - a) Output frequency = 1 Hz
 - b) "A" = AC-coupled receiver
 - c) "A" = AC-coupled receiver
 - d) "5" = 500mV swing

SiT1544

Smallest Footprint (1.2mm²), Ultra-Low Power 1 Hz - 32.768 kHz
Programmable Oscillator for Li+ Unregulated Battery Powered Applications



© SiTime Corporation 2013. The information contained herein is subject to change at any time without notice. SiTime assumes no responsibility or liability for any loss, damage or defect of a Product which is caused in whole or in part by (i) use of any circuitry other than circuitry embodied in a SiTime product, (ii) misuse or abuse including static discharge, neglect or accident, (iii) unauthorized modification or repairs which have been soldered or altered during assembly and are not capable of being tested by SiTime under its normal test conditions, or (iv) improper installation, storage, handling, warehousing or transportation, or (v) being subjected to unusual physical, thermal, or electrical stress.

Disclaimer: SiTime makes no warranty of any kind, express or implied, with regard to this material, and specifically disclaims any and all express or implied warranties, either in fact or by operation of law, statutory or otherwise, including the implied warranties of merchantability and fitness for use or a particular purpose, and any implied warranty arising from course of dealing or usage of trade, as well as any common-law duties relating to accuracy or lack of negligence, with respect to this material, any SiTime product and any product documentation. Products sold by SiTime are not suitable or intended to be used in a life support application or component, to operate nuclear facilities, or in other mission critical applications where human life may be involved or at stake. All sales are made conditioned upon compliance with the critical uses policy set forth below.

CRITICAL USE EXCLUSION POLICY

BUYER AGREES NOT TO USE SITIME'S PRODUCTS FOR ANY APPLICATION OR IN ANY COMPONENTS USED IN LIFE SUPPORT DEVICES OR TO OPERATE NUCLEAR FACILITIES OR FOR USE IN OTHER MISSION-CRITICAL APPLICATIONS OR COMPONENTS WHERE HUMAN LIFE OR PROPERTY MAY BE AT STAKE.

SiTime owns all rights, title and interest to the intellectual property related to SiTime's products, including any software, firmware, copyright, patent, or trademark. The sale of SiTime products does not convey or imply any license under patent or other rights. SiTime retains the copyright and trademark rights in all documents, catalogs and plans supplied pursuant to or ancillary to the sale of products or services by SiTime. Unless otherwise agreed to in writing by SiTime, any reproduction, modification, translation, compilation, or representation of this material shall be strictly prohibited.