

GENERAL DESCRIPTION

This interface allows to control **imperix** power modules with an **Speedgoat** simulator. It provides the necessary signal connections and transformations to easily wire the digital outputs of the Speedgoat hardware to the command inputs of the power modules, and retrieve any useful measurement to its analog inputs.

The user is responsible of the behavior of the Speedgoat controller. In particular, the complementarity of the gating signals must be ensured at all time, when the control algorithm is running. It is recommended to power down and discharge the converter prior to any operation that could lead to hazardous gating signals, such as starting up/shutting down the controller, flashing code, disconnecting cables, etc. In addition, only one external power supply must be connected to the power interface at a time. Disregarding this warning may lead to injury and/or cause serious damage.

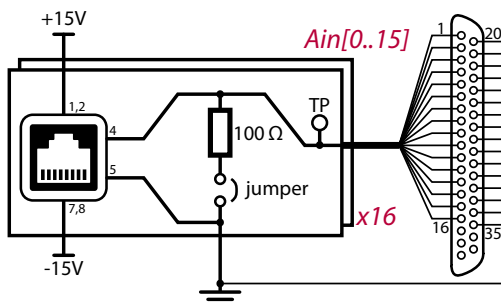
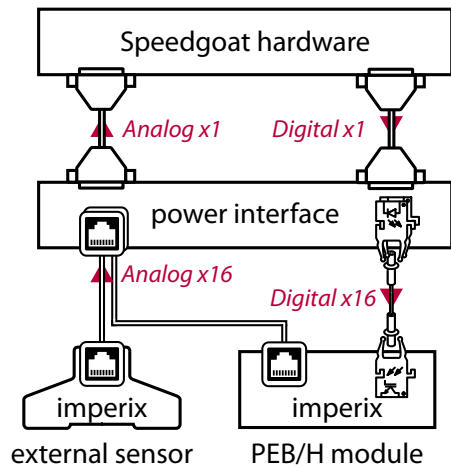

ANALOG INPUTS

- 16 channels, RJ45 connectors, -10 to 10V input voltage
- Configurable high-Z or low-Z input (connect jumper for 100Ω low-Z)
- +15V/-15V sensor supply (max 100mA/ch, 800mA tot)

POWER SUPPLY

- 5V / +15V / -15V external supply required
- Approx. max consumption: 5W / 12W / 12W
- Recommended external supply: *XP Power AEH45UM32*
- Connector pinouts:

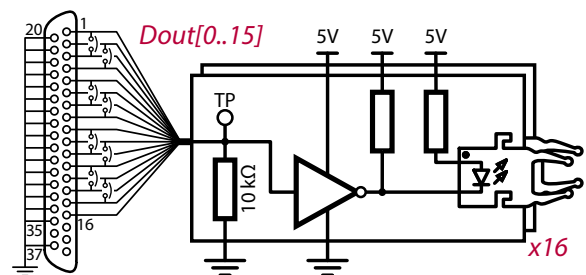
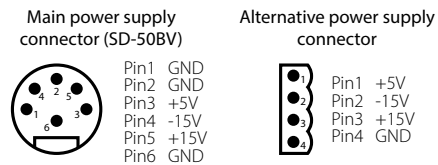

DIGITAL OUTPUTS

- 8 pairs of independent channels
- Optical fiber wiring of the gating signals to imperix PEB or PEH power modules
- Max. prop. delay difference between 2 channels: 80ns
- Signals # 1, 2, 5, 6, 9, 10, 13, 14, can be duplicated with 0Ω jumpers for controlling 2 paralleled power modules with 1 digital signal

CONTACT

Imperix Ltd.
Rue de la Dixence 10, 1950 Sion, Switzerland
www.imperix.ch, sales@imperix.ch

ABOUT US

Imperix develops high-end control equipment and prototyping hardware for power electronics, drives, smart grids and related topics. Its products are designed to accelerate the implementation of laboratory-scale power converters and facilitate the derivation of high quality experimental results.