

LCD Module Specification

First Edition	Approved by	Production DIV
Mar 05, 2003	Checked by	Quality Assurance DIV
Final Revision	Checked by	Engineering DIV
0.02	Drawn by	Engineering DIV

Type No.	T-51686GD049H-FW-AA
----------	----------------------------

Table of Contents

1. Application	2
2. Mechanical Specification	2
3. Absolute Maximum Ratings	3
4. Environment Condition	3
5. Optical Characteristics	4
6. Electrical Characteristics	10
7. Product Standard	18
8. Reliability Test	19
9. Code System of Production Lot	21
10. Packing Specification	22
11. Product handling Cautions	23
12. Condition for Guarantee	24

Revision History

Rev.	Date	Page	Comment
001	Des 12,2002		First Edition
002	Mar 12,2003		Second Edition



1.Application

This technical specification applies to 4.9? color TFT-LCD module (T-51686GD049H-FW-AA). The applications of the panel are car entertainment and car navigation.

2.Mechanical Specifications

Screen Size	: 4.9 inches (12.5cm)
Display Mode	: Normally White
Driving Method	: a-Si TFT Active Matrix Format
Display Format	: 320(W) × 96(H)
Resolution	: 960(W) × 96(H)
Dot Pitch	: 0.125 (W) × 0.375 (H) mm
Pixel Configuration	: RGB Stripe
Active Area	: 120.0 (W) × 36.0 (H) mm
Outline Dimension	: 138.0 (W) × 48.0 (H) × 12.0 (D) mm
Weight	: TBD
Backlight	: Cold Cathode Fluorescent Lamp
Surface Treatment	: AG coating
Attached Drawing	: Dimensional Outline UE-311499-00

3. Absolute Maximum Ratings

Parameter	Symbol	Condition	Min.	Max.	Units
Supply voltage	V _{DD}	Ta=25±5°C V _{SS} =0V	-0.3	6.5	V
	V _{GH}		-0.3	+44.0	V
	V _{EE}		V _{GG} ? 45.0	V _{GG} +0.3	V
Signal Input Level	V _{DATA}		-0.3	V _{DD2} +0.3	V
	V _{LOGIC}		-0.3	V _{DD1} +0.3	V
Storage Temperature	T _{stg}	—	-40	+85	°C
Operation Temperature	T _{opr}	—	-30	+85	°C

Note: Absolute maximum ratings should not exceed the limit any time. If the product exceeds the limit, it may cause damage. Please be cautious to the changes in supply voltage, connection parts, surge of signals, and surrounding temperature.

4. Environment Condition

Parameter		Condition	Range	Remark
Operating Temperature Range	LCD Module w/ Backlight	Surrounding Temperature (Panel Surface Temperature)	-30~85°C (-30~85°C)	Note 4-1,4-2
	LCD Panel	Surface Temperature	-30~75°C	
Storage Temperature Range	LCD Module w/ Backlight	Surface Temperature	-40~85°C	Note 4-3
	LCD Panel	Surface Temperature	-40~85°C	

Note 4-1: Operating temperature range defines the operation only and the contrast, response time, and other display optical characteristics are set at Ta=+25°C.

Note 4-2: Panel surface temperature indicates the temperature of the back light panel surface on the five points from the four corners and the center. Also note that the panel temperature of backlight side is 10°C (reference value) higher than the other side.

Note 4-3: Backlight is not activated.

5. Optical Specifications

Parameter	Symbol	Conditions			Standard Value			Units	Method of Measurement	Remark
		θ	ϕ	C	Min.	Typ.	Max.			
(1)Luminance	B	0°	0°	/	—	350	—	cd/m ²	(D5-1)	N5-1
(2)Contrast Ratio	CR	Optimum Viewing Angle			60	150	—	—		
(3)White Chromaticity	X	0°	0°	/	0.295	0.345	0.395	—		
	Y	0°	0°	/	0.305	0.355	0.405	—		
(4)Luminance Irregularity	—	0°	0°	/	0.7	—	—	—	(D5-2)	
(5)Vertical Viewing Angle	Up	θ_U	—	0°	≥ 10	—	(40)	—	degree	(D5-3)
	Down	θ_D	—	0°	≥ 10	—	(50)	—	degree	
(6)Horizontal Viewing Angle	Left	Φ_L	0°	—	≥ 10	—	(50)	—	degree	
	Right	ϕ_R	0°	—	≥ 10	—	(50)	—	degree	
(7)Response Time	Rise	τ_r	0°	0°	/	—	(30)	TBD	ms	(D5-4)
	Decay	τ_d	0°	0°	/	—	(50)	TBD	ms	

N5-1 : Under the condition of 6.0mA

- ◆ Conditions for Measuring
 - ◇ Environment: Dark room with no light or close to no light.
 - ◇ Temperature: 25+/-5°C
 - ◇ Humidity: 40-70%RH
 - ◇ After backlight has been lit more than 30 minutes, driving voltage is set for optimal contrast to measure center of display.
 - ◇ Measure by the specified inverter or similar product.
- ◆ Optimal viewing angle (The angle with best contrast)

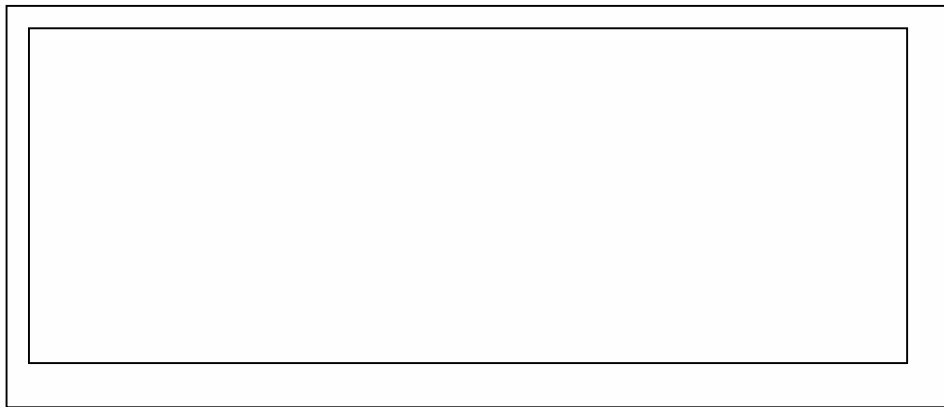

6 O'clock

(D5 - 1)

◆ Method of Luminance Measurement

(1) Measuring Device

TOPCON BM-7, Measuring Field : 1°

(2) Measuring Point

Center of Display $\theta = 0^\circ$ 、 $\phi = 0^\circ$

On condition θ : A vertical angle from measuring direction to perpendicular.

ϕ : A horizontal angle from measuring direction to perpendicular.

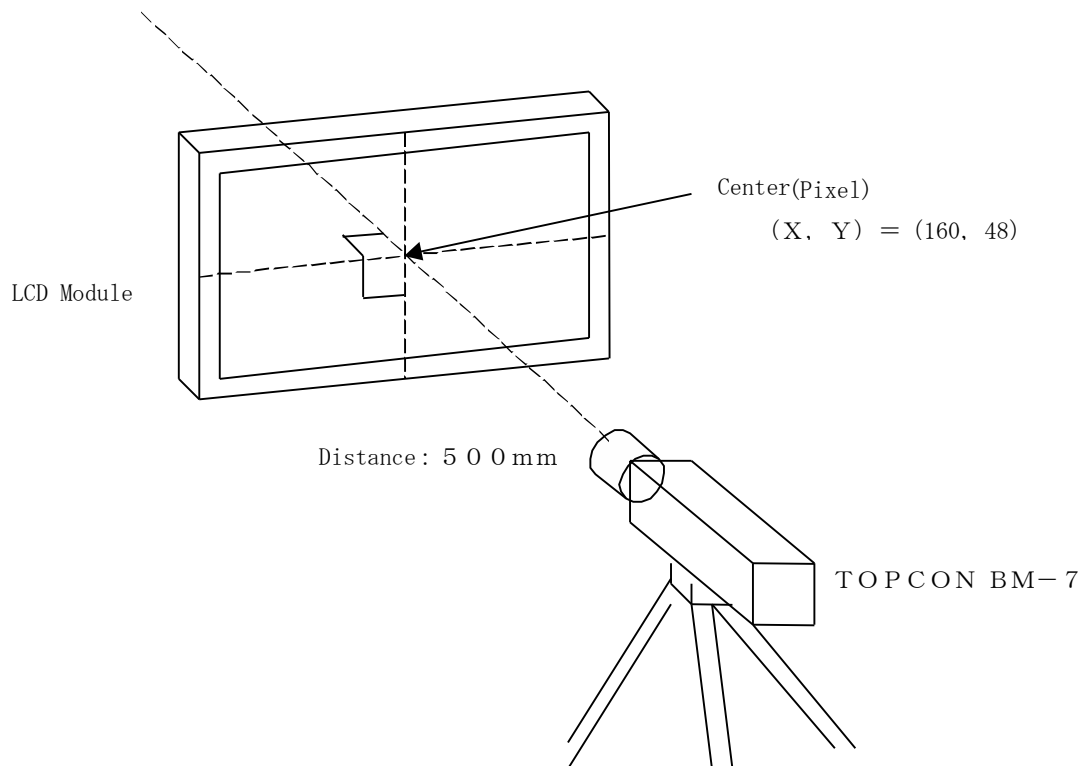

(3) Method of Measuring

Apply signal voltage (displayed in white) to maximize luminance and measure luminance B (cd/m^2).

The distance between BM-7's front lens to surface panel is 500mm.

Measured after backlight has been lit for more than 30 minutes.

◆ Method of Contrast Measurement

(1) Measuring Device

TOPCON BM-7, Measuring Field : 1°

(2) Measuring Point

Center of display: same as Method of Luminance Measurement

(3) Method of Measuring

- Set LCD module to $\theta = 0^\circ, \phi = 0^\circ$.
- Change signal voltage to measure maximum luminance Y1 and minimum luminance Y2.
- Contrast is derived from $CR=Y1/Y2$.

(D 5 - 2)

◆ Definition of Luminance Irregularity

Definition is calculated from the five points (S0-S4) on the diagram below.

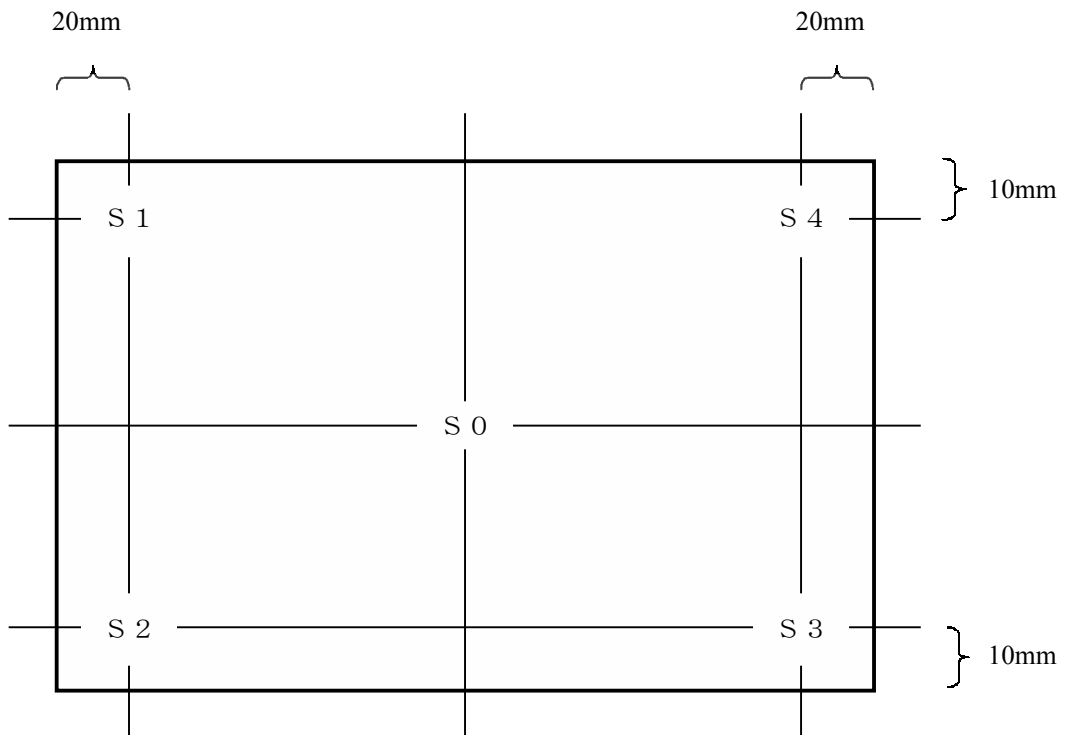

$$\text{Standard value of luminance irregularity} = \frac{\text{Minimum value of S1-S4}}{S0}$$

(D5 - 3)

◆ Method of Viewing Angle Measurement

(1) Measuring Device

TOPCON BM-7, Measuring Field : 1°

(2) Measuring Point

Center of display: Same as Method of Luminance Measurement

(3) Angle of Measuring

θ : An angle vertical to perpendicular line from the viewing direction.

Φ : An angle horizontal to perpendicular from the viewing direction.

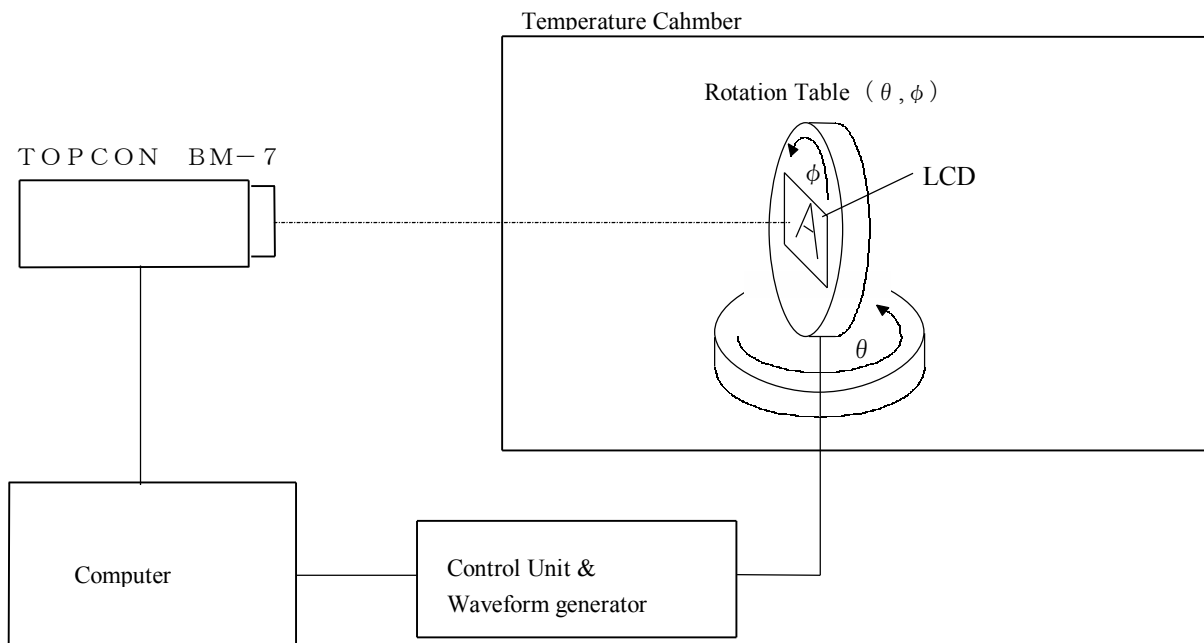

(4) Method of Measuring

Set rotation table to $\phi = 0^\circ$ and set BM-7 to contrast 10 to measure angle $\pm\theta$ for left and right direction of horizontal viewing angle ϕ . Also set rotation table to $\phi = 90^\circ$ and set BM-7 to contrast 10 to measure angle $\pm\theta$ for up and down direction of vertical viewing angle θ .

(D5 - 4)

◆ Measuring Response Time

(1) Measuring Device

TOPCON BM-7, Measuring Field : 1°
Tektronix Digital Oscillo-Scope

(2) Measuring Point

Center of display, same as Method of Luminance Measurement

(3) Method of Measuring

- Set LCD panel to $\theta = 0^\circ$, and $\phi = 0^\circ$.
- Input white → black → white to display by switching signal voltage.
- If the luminance is 0% and 100% immediately before the change of signal voltage, then τ_r is optical response time during the change from 90% to 10% immediately after rise of signal voltage, and τ_d is optical response time during the change from 10% to 90% immediately after decay of signal voltage.

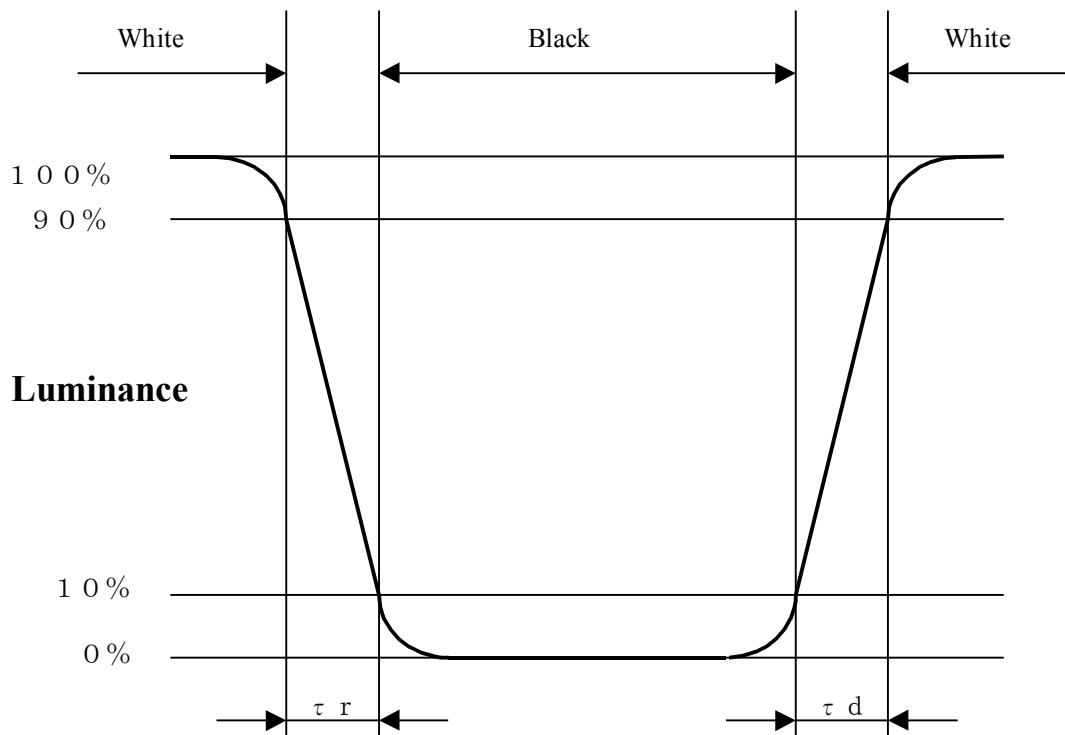

6. Electrical Characteristics

6.1. Description

Parameter	Description	Remark
Display Size	4.9? wide (12.5cm)	
Display Method	TN full color (transmitting type)	Normally White
Driving Method	a-Si TFT Active Matrix Line Scanning	
Pixel Alignment	RGB Stripe alignment	
Visual Signal Input Method	RGB x 6bits	(D6-1)
	CMOS level	(D6-2)
Controlled Signal Input Method	CMOS Level	
Backlight	Cold cathode lamp, Edge light	

6.2. Pixel Alignment

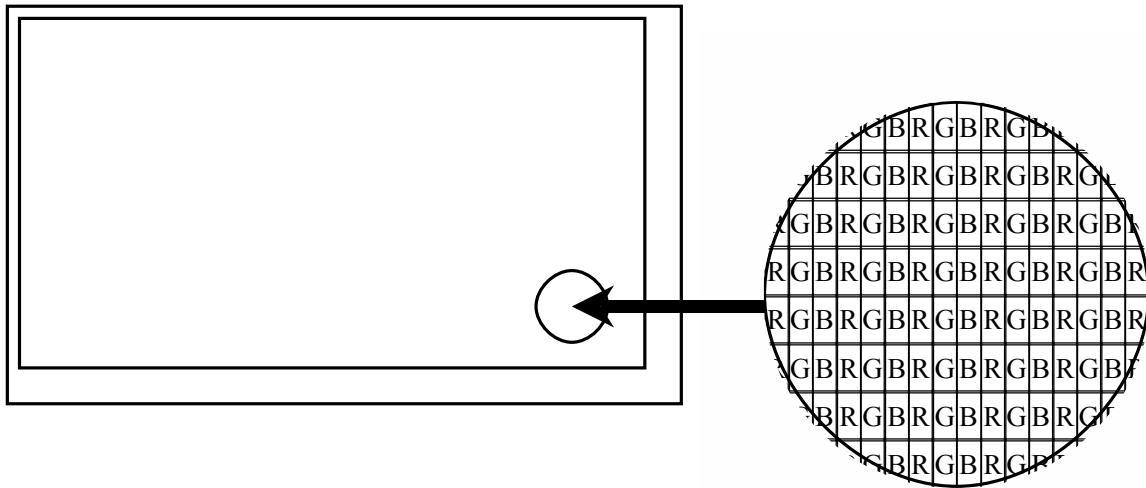

Pixel Alignment

6.3.PIN Alignment of Interface Input

No.	Symbol	Level	Function	I/O	Remark
1	VGH	—	(+15V) power supply	I	
2	ENAB	H/L	Signal to settle the horizontal display position	I	
3	HVR	H/L	Selection for horizontal display position	I	
4	B5	H/L	Blue data signal(MSB)	I	
5	B4	H/L	Blue data signal	I	
6	B3	H/L	Blue data signal	I	
7	B2	H/L	Blue data signal	I	
8	B1	H/L	Blue data signal	I	
9	B0	H/L	Blue data signal(LSB)	I	
10	VDD	-	+5V Power Supply	I	
11	VDD	-	+5V Power Supply	I	
12	G5	H/L	Green data signal(MSB)	I	
13	G4	H/L	Green data signal	I	
14	G3	H/L	Green data signal	I	
15	G2	H/L	Green data signal	I	
16	G1	H/L	Green data signal	I	
17	G0	H/L	Green data signal(LSB)	I	
18	V _{SS}	-	Power Supply (0V,GND)	I	
19	R5	H/L	Red data signal(MSB)	I	
20	R4	H/L	Red data signal	I	
21	R3	H/L	Red data signal	I	
22	R2	H/L	Red data signal	I	
23	R1	H/L	Red data signal	I	
24	R0	H/L	Red data signal(LSB)	I	
25	V _{GL}	-	(-12.5V)power supply	I	
26	V _{sync}	H/L	Vertical synchronous signal	I	
27	H _{sync}	H/L	Horizontal synchronous signal	I	
28	V _{SS}	—	Power supply(0V,GND)	I	
29	CK	H / L	Clock signal for sampling each data signal	I	
30	V _{SS}	—	Power supply(0V,GND)	I	

Qualified Connector: SFR30R-1STE1(Nihon FCI Co.,LTD)

6.4. Block Diagram

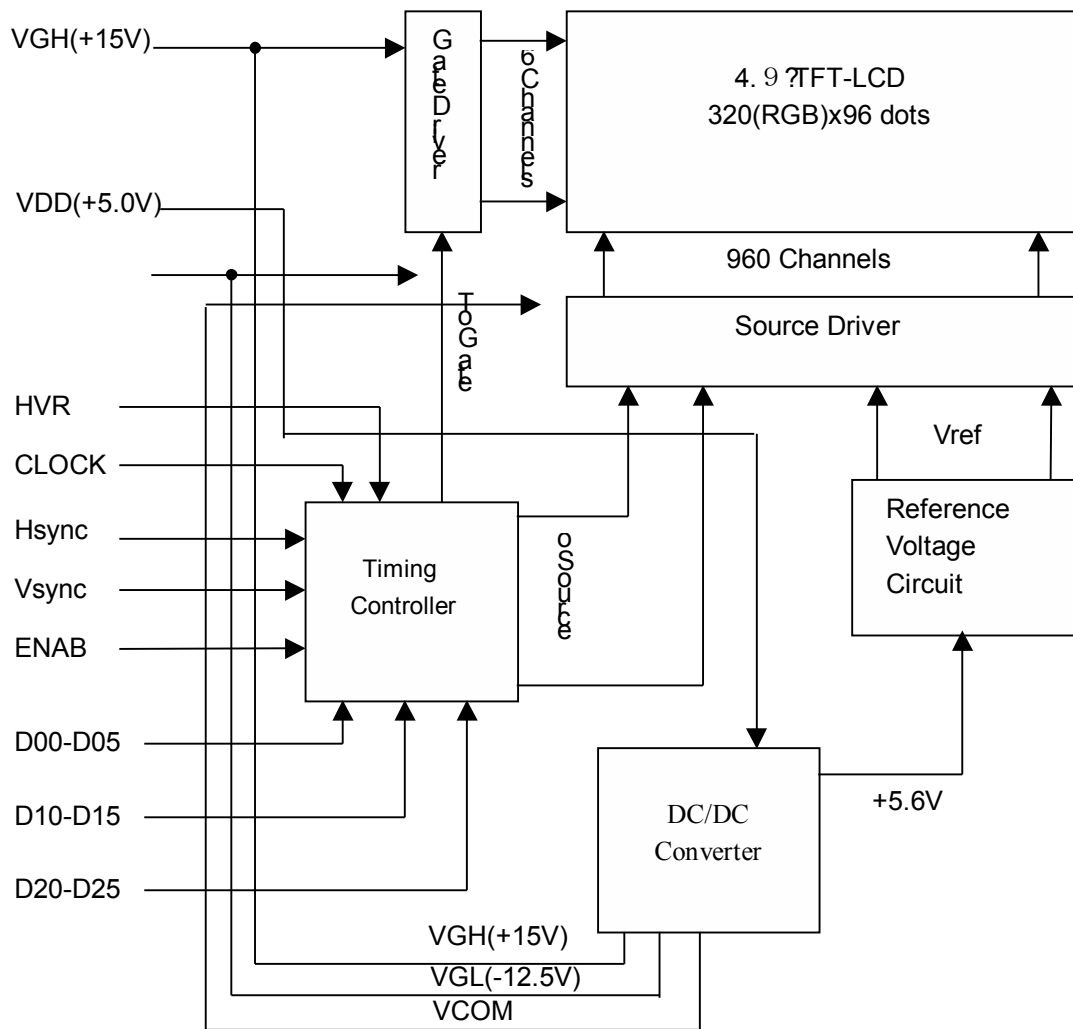

6.5.Operation Condition for LCD Module

Ta=25°C, Vss=0V

Parameter	Symbol	Min.	Typ.	Max.	Units	Remark
Supply Voltage for Analog	V _{DD}	4.9	5.0	5.1	V	
Logic Voltage	V _{IL}	V _{SS}		0.3xV _{DD}	V	
	V _{IH}	0.7xV _{DD}		V _{DD}	V	
Gate Driver Plus	V _{GH}	14.0	15.0	16.0	V	
Gate Driver Minus	V _{GL}	-13.0	-12.5	-12.0	V	
Logic	I _{DD}		(50)	(80)	mA	
Gate Driver	I _{GH}		(10)		mA	
Gate Driver	I _{GL}		(10)		mA	

Note: The recommended conditions are the range of driver guaranteed and operating beyond the range, the driver will not be guaranteed even if it is within the absolute values.

6.6 Timing Specification

a. Pixel Timing Chart

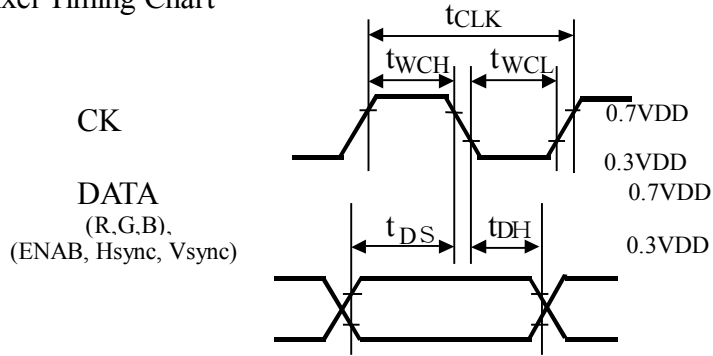

b. Horizontal Timing Chart

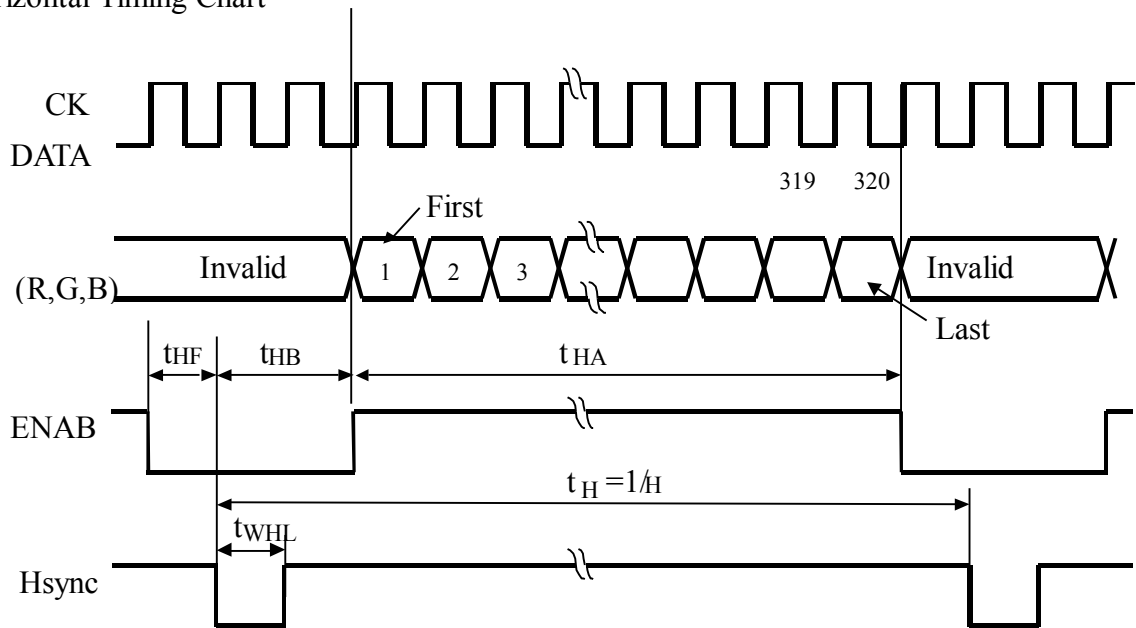

c. Vertical Timing Chart

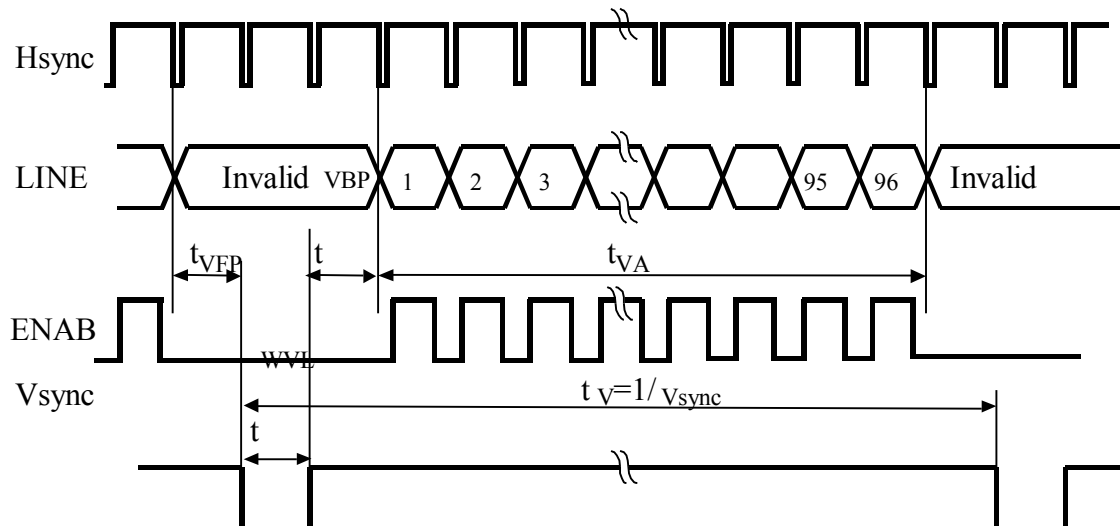

(1) Timing Specifications

VCC=5.0V, Ta=25°C

ITEM	SYMBOL	MIN	MIN	TYP	MAX	UNIT
DCLK *1) *4)	Frequency	fCLK	2.38	2.516	2.63	MHz
	Period	tCLK	380	–	420	nS
	Low Width	tWCL	180	198.5	–	nS
	High Width	tWCH	180	198.5	–	nS
DATA *1) (R,G,B,DENA,HD,VD)	Set up time	tDS	5	–	–	nS
	Hold time	tDH	5	–	–	nS
ENAB *3)	Horizontal Active Time	tHA	320	320	320	tCLK
	Horizontal Front Porch	tHFP	10	–	–	tCLK
	Horizontal Back Porch	tHBP	10	–	–	tCLK
	Vertical Active Time	tVA	96	96	96	tH
	Vertical Front Porch	tVFP	3	–	–	tH
	Vertical Back Porch	tVBP	3	–	–	tH
HD *2) *4)	Frequency	fH	6.1	6.3	6.5	kHz
	Period	tH	154	159	164	uS
	Low Width	tWHL	5	–	–	tCLK
VD *2)	Frequency	fV	58.04	59.94	61.84	Hz
	Period	tV	16.2	16.7	17.2	ms
	Low Width	tWVL	1	–	–	tH

[Note]

- *1) DATA is latched at fall edge of CK in this specification.
- *2) Polarities of Hsync and Vsync are negative in this specification.
- *3) ENAB (Data Enable) should always be positive polarity as shown in the timing specification.
- *4) CK should appear during all invalid period, and Hsync should appear during invalid period of frame cycle.

6.7. Power Supply Sequence

Please follow below for power supply sequence.

When the power is on, all power source is assumed to be at 90% and when power is off, all power source is assumed to be at 10%. The time frame is assumed to be more than 60ms.

Please avoid any single power source to be outside of the sequence written below.

Power ON Sequence	$V_{DD} \rightarrow V_{GH}, V_{GL}$ (+5.0V) (+15.0V) (? 12.5V)
Power OFF Sequence	$V_{GL}, V_{GH} \rightarrow V_{DD1}$ (? 12.5V) (+15.0V) (+5.0V)

All signals supplied to module other than for power should be handled after Power ON sequence has been completed and all signals other than for power should be turned off before the Power OFF sequence.

6.8. Backlight

Parameter	Symbol	Min.	Typ.	Max.	Units	Remark	
Circuit	IL	—	6	—	m Arms	*1	
Voltage	VL	—	340	—	V rms	*2	
Power Consumption	PL	—	2.04	—	W	*3	
Lighting Cycles	FL	—	(47.2)	—	k H z	*4	
Lighting Voltage	VS	—	(950)	—	V rms	Ta=25°C	*2
		—	(1300)	—		Ta=0°C	
Longevity	—	20000	—	—	Time	*2,4	

*1 : Panel surface temperature shall not exceed 70°C under 6.5mA.

*2 : Reference derived from the use of lamp.

*3 : Lighting cycles and horizontal display synchronization may influence each other creating strips on screen. To avoid it, please use them in distance to keep harmonic frequency far away as possible, Connect Metal shield case of LCD module to inverter GND, or shield the driving circuit board.

*4 : When the luminance of lamp is 50% of initial luminance (Under setting of $T_a = 25^\circ\text{C}$ and continuous standard lighting.)

Status of module set up, or placement of backlight lead line may cause dispersion of luminance. So please, confirm on the actual product. Please check the backlight lead line to confirm the metal frame of GND or lead line is not in contact, which will assure safety and reduce the dispersion.

It is important to match with the characteristics of the lamp when inverter has been installed in the actual product. For inverter designing please consult with us.

Lamp Connector

Terminal	Symbol	Function	
1	V _{FLH}	Cold cathode lamp	Cable color: Pink
2	V _{FLL}	Cold cathode lamp	Cable color: White

Connector in use: BHSR-02VS-1

7. Product Standard (Tentative)

7.1.1 Inspection Standard

Inspection condition is as follows:

- Viewing distance is approximately 35cm.
- Viewing angle is normal to the LCD panel.
- Ambient temperature is approximately 25°C.
- Ambient light is from 300 to 500 lx.

Bright Dot is defined as follows:

Visible through 5% transmission ND filter under the condition that black image (color 0) is on the display.

DEFECT TYPE		LIMIT	
VISUAL DEFECT	SCRATCH	0.01 mm < W □ 0.05 mm L □ 10 mm	N □ 4
		0.01 mm □ W 10 mm < L	N = 0
		0.05 mm < W	N = 0
	DENT	0.15 mm < φ □ 0.4 mm	N □ 4
		0.4 mm < φ	N = 0
	BLACK SPOT BUBBLE	0.15 mm < φ □ 0.5 mm	N □ 2
		0.5 mm < φ	N = 0
	LINT	L □ 3 mm W □ 0.1 mm	N □ 2
3mm < L 0.1mm < W		N = 0	
ELECTRICAL DEFECT	BRIGHT DOT	Zone A	0
		Zone B	1
	DARK DOT	Zone A	3
		Zone B	3
	TOTAL DOT	6	
	TWO or MORE ADJACENT DOT BRIGHT DOT DARK DOT	NOT ALLOWED Two adjacent dots are counted for two dark dots More than two adjacent dots are not allowed	
	DISTANCE BETWEEN DEFECTS LINE DEFECT	□ 5mm NOT ALLOWED	

*1) W: width, L: length, φ: diameter, N: number

*2) DEFINITION OF ADJACENT

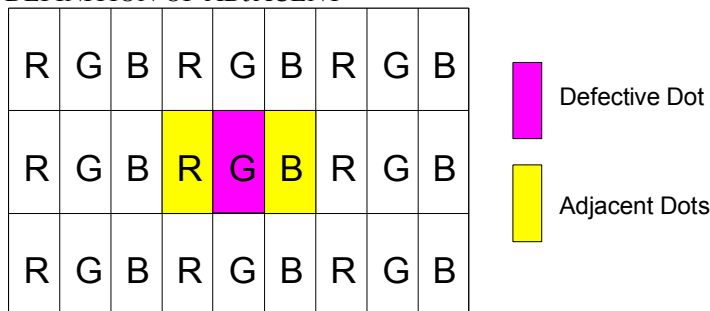

*3) Dot defect is defined that the defective area of the dot is larger than 50% of the dot area.

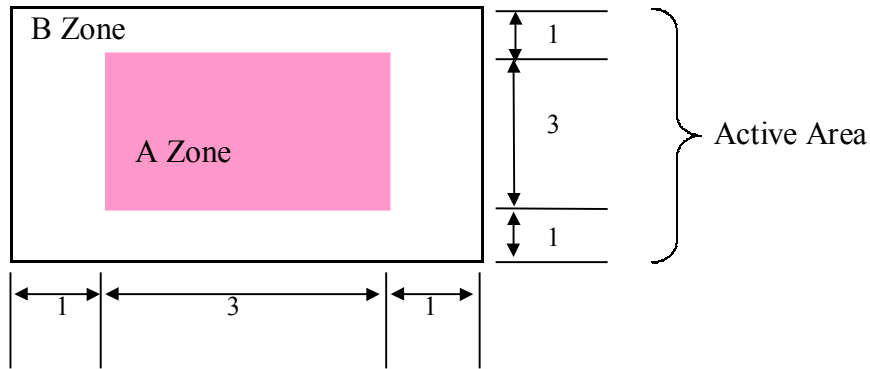

The defects that are not defined above and considered to be problem shall be reviewed and discussed by both parties.

7.1.2.External Appearance

All standards follow the measurement designated by the external appearance drawing.

8.Reliability Test

8.1.Mechanical and Environmental Test

Parameter	Condition	Test hour	Remark	
E n v i r o n m e n t	High temp operation	Ta=65±2°C, 45%RH Below	192 hrs	Note1
	High temp & high humidity operation	Ta=65±2°C, 90±2%RH, No Condensation	192 hrs	Note1
	Low temp operation	Ta=-30±3°C	192 hrs	Note1
	High temp storage	Ta=85±2°C, 45%RH below	192 hrs	Note1
	Low temp storage	Ta=-40±3°C	192 hrs	Note1
	Light resistance	Sunshine carbon arc Ta=63±2°C	360 hrs	
H u m i d i t y	Drastic temp change	-30°C(60min)⇔25°C(15min)⇔80°C(60min), No electric path	20 cycle	Note2
	Condensation	-30°C(30min non-operating), 25°C/95%RH(10min operating) Dried after specified cycle and confirm operation	10cycle	
	Humidity cycle	1cycle=48hrs non-operational 	5cycle	
E l e c t r i c	Static resistance	C=200pF, R=0Ω, V=±150V 3 discharge on electric and other terminal, non-operational	—	
	Electric discharge	C=150pF, R=150Ω, V=±15kV Discharge ±charges 5 times each on panel and earth, non-operational	—	
Vibration	5~10Hz, width 25mm 10~30Hz, 3.7×9.8m/s ² 30~50Hz, 1.6×9.8m/s ² 50~80Hz, 0.7×9.8m/s ² 80~100Hz, 0.3×9.8m/s ²	X,Y,Z all dir 8min×2sweep non-operational	All dir 96 hrs	

Shock	980m/s ² , t=6ms, X,Y,Z all dir2,semi-sine-wave, non-operational	—	
Terminal durability	Apply 500g of weight perpendicular to end of terminal Onon-operational	—	
External durability	Apply pressure on the center of the screen by push/pull gauge. head diameter is φ 12mm、 pressured apply 5 ×9.8N(=5kgf) once, non-opreatioal	—	
Pressure resistance	5 ×10 ⁴ Pa(=0.5Pressure)、 non-operational	2 hrs	

Note 1: High temperature operation, high temperature & high humidity operation, low temperature operation, high temperature storage and low temperature storage will test it's ability for 1000 hours to confirm. The deterioration of plarizer is disregarded.

Note 2: Drastic tempertaure change test will continue the inspection under same condition consecutiely to confirm it's ability. Test will be done mounted in your request kit.

8.2. Reliability Test Standard

Parameter		Optical & Electrical Specifications				Quality of Screen
		Contrast	Surface luminance	Response time	Circuit	
E o o o o o	High temp operation *	>30	within ±20%	within ±20%	Within + 40%	Not to be conspicuous
	High temp & high humidity operation *	>25	//	//	//	//
	Low temp operation *	>30	//	//	//	//
	High temp storage *	//	//	//	//	//
	Low temp storage *	//	//	//	//	//
	Light resistance *	//	//	//	//	//
H o o	Drastic temp change *	//	//	//	//	//
	Condensation※	>25	//	//	//	//
	Humidity cycle※	//	//	//	//	//
E o o	Static resistance	No abnormalities in system and display.				
	Electric discharge	No damage should be done				
M o o o o	Vibration	No abnormalities in system and display.				
	Shock	No abnormalities in system and display.				
	Terminal durability	No abnormalities in system and display.				
	Exterior durability	No abnormalities in system and display.				
	Pressure durability	No abnormalities in system and display.				

Note : * indicates that test was performed in room temperature, more then 2 hours after it was taken out from chamber.

※indicates that test was performed after 24 hours after it has been taken out from chamber.

Luminance, circuit, response time changes are compared from the initial standard values.

9.Code System of Production Lot

9.1.Production Lot Number

Module's production Lot Number will be indicated as below.

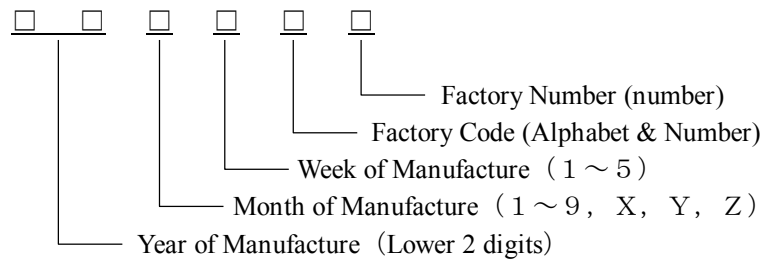

9.2.Type Number

The type number of module is specified on the back of module as follows;



9.3.Precautions under Operation

When questions arise concerning this specifications or new problems not specified in this specifications arise, problems related to the specification is to be discussed for solution.

10.Packing Specification

T B D

11.Product Handling Cautions



In order to use the products properly please note the following precautions.

1) For LCD screen

- ① LCD particles used in LCD module is made into form of glass board. Do not apply any strong physical shock.
If it cracks, handle with extra caution to avoid any harm.
- ② The polarizer attached on the surface of LCD particles are composed by soft materials. Please do not scratch them.

2) Handling LCD module (static electricity countermeasure)

- ① Please ground all human bodies and electrical facilities. Also on the operation line, anti-static electricity mat (rubber) is recommended to avoid electric shock in case of accident.
- ② Working uniform should avoid synthetic fiber and recommend the use of cotton or non-electrical conducting fiber.
- ③ When removing protective film from LCD panel, please remove it slowly to avoid development of static electricity.

3) For Storing Single LCD module for long term

- ① Do not store under high temperature and high humidity.
- ② Do not expose the module to direct sunlight or intensive ultraviolet rays for many hours.
- ③ Avoid any force applied from external environment.

4) LCD module does not have circuit for over current protection. For in case of accident, please use power supply with over current protection.

5) If LCD panel breaks, it is possible that the liquid crystal leaks from the panel. Avoid putting it into eyes or mouth. When liquid crystal sticks on hands, clothes, or feet. Wash it out immediately with soap.

6) When using product with metal holder, if metal holder and the body are not soldered, sooth electric flow is not guaranteed. To secure the flows of electricity, please consult.

7) For products that requires the use of C F L

- ① On the connection of CFL cable more then 1000 v high voltage is applied. Please handle with care to avoid any burn upon contact.
- ② Please be careful if overcoat of CFL cable is in the status of abrasion by the contact with the system.
- ③ Continuous use of CFL at low temperature, will shorten longevity of CFL compared to it's use at room temperature.

8) For products that uses touch panel

- ① Do not stack panel on top of each other. There may be possibility of harm caused by the edge of panel.
- ② Do not place any heavy objects above panel.

9) For product that uses COG, TAB, and COF

- ① The back side of IC hip is exposed and has low intensity. Upon handling, do not apply powerful pressure to the IC chip.
- ② IC chip backside is exposed and should not be equipped with any setup that releases electrical contact to prevent electrical damage. Also to prevent unintentional function by light and to keep it's electrical characteristics, set up to avoid exposure to light.

10) For product that uses FPC, heal seal and TAB

- ① To maintain reliability, do not hold onto connection section.
Do not bend or pull lines with strong power. It could snap the lines.

12. Condition for Guarantee.

Our product is designed and manufactured by your specification requirement as a part for final electrical products. We will guarantee the product has no sign of defect and meet all qualifications of your request. However, if the final product was not for common household use, but instead used for medical, nuclear controller, aviation, disaster prevention or any other products that require extreme reliability, we can not be held responsible for any quality guarantee issue.

If the product was placed for any of the use above, we ask for revision on our contract for manufacturing this product.

- 1) After delivery, any modification (including restructure and taking apart) of the product we can not hold any responsibility for quality guarantee issue.
- 2) Any damage caused by the outside force, we can not hold any responsibility for quality guarantee issue.
- 3) After completing all product inspection and after delivery from the factory, any static electricity applied on product, we can not hold any responsibility for quality guarantee issue.
- 4) Upon using product with CFL, longevity and luminance may altar by the performance of inverter or leakage. We can not hold any responsibility for quality guarantee issue by performance or reliability of final product.
- 5) Any product that uses our product within, we will not hold any responsibility for any problems that has no relationship with the structure or performance of our product.

ISSUE	REVISIONS	DRAWN	APPROVED	DATE
1	CHANGED CN1 PIN LAYOUT.	M. Nakada	H. Morosawa	DEC. 17 '02
2	CHANGED DES(IGN).	M. Nakada	Y. Takada	FEB. 17 '03

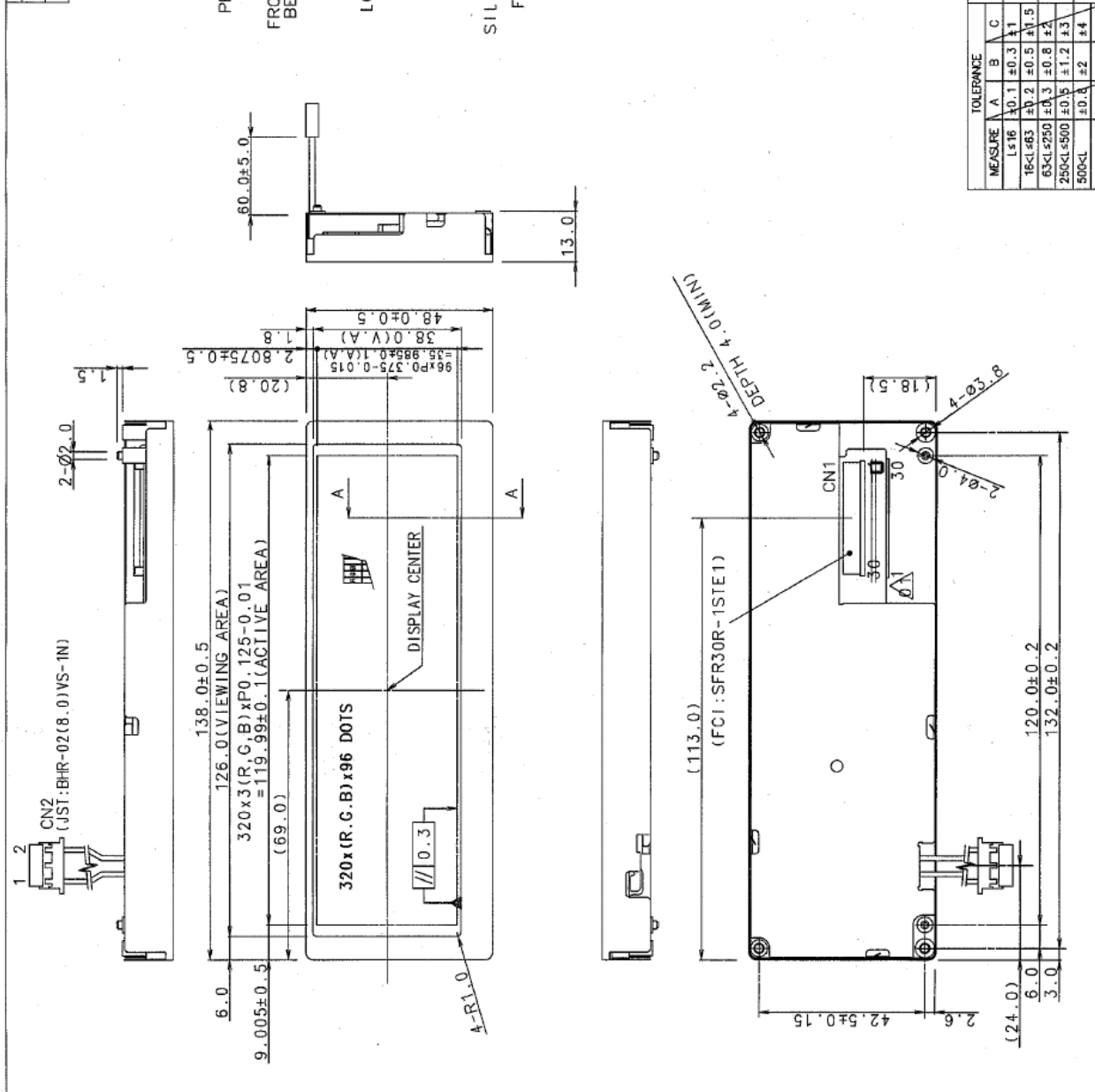

PIN ASSIGNMENT

No.	Symbol	CN1
1	VGH	
2	ENAB	
3	HVR	
4	B5	
5	B4	
6	B3	
7	B2	
8	B1	
9	B0	
10	VDD	
11	VDD	
12	G5	
13	G4	
14	G3	
15	G2	
16	G1	
17	G0	
18	VSS	
19	R5	
20	R4	
21	R3	
22	R2	
23	R1	
24	R0	
25	VGL	
26	VSYNC	
27	HSYNC	
28	VSS	
29	CK	
30	VSS	

No.	Symbol	CN2
1	H.V	
2	L.V	

MEASURE	TOLERANCE	3RD ANGLE PROJECTION	DATE
L≤16	±0.1	±0.3	DEC. 03 '02
16<L≤63	±0.2	±0.5	APPROVED
63<L≤250	±0.3	±0.8	H. Morosawa
250<L≤500	±0.5	±1.2	CHECKED
500<L	±0.8	±2	Y. Takada
ANGLE	±1°	±5°	DRAWN
			M. Nakada

UNIT	SCALE	CODE	DRW NO
MM	1:1	T-51686GD049H-FW-AA	UE-311499-02

OPTREX CORPORATION		DIMENSIONAL OUTLINE	
DATE		TITLE	
DEC. 03 '02		T-51686GD049H-FW-AA	
APPROVED		CODE	
H. Morosawa		T-51686GD049H-FW-AA	
CHECKED		DRW NO	
Y. Takada		UE-311499-02	
DRAWN		M. Nakada	