

**LCD Module Technical Specification**

Spec No.

-

Part No.

T-55788GD121J-LW-ACN

Page

1

**1. Application**

This document defines the specification of T-55788GD121J-LW-ACN. (RoHS Compliant)

**2. Construction and outline**

LCD	: Transmissive color dot matrix type TFT
Backlight system	: LED
Polarizer	: Anti-Glare treatment
Interface	: LVDS
Additional circuit	: Timing controller, Power supply (3.3V input) : Constant current circuit for LED Backlight(12V input)

**3. Mechanical specifications**

Item	Specification	Unit
Outline dimensions 1)	260.5(W) × 203.3(H) × 9.5(D)	mm
Active area	246(W)×184.5(H) (30.8cm/12.1 inch(Diagonal))	mm
Dot format	800×(R,G,B)(W)×600(H)	dot
Dot pitch	0.1025(W)×0.3075(H)	mm
Base color 2)	Normally Black	-
Mass	(650max)	g

1) Projection not included. Please refer to outline for details.

2) Due to the characteristics of the LCD material, the color varies with environmental temperature.

## LCD Module Technical Specification

Spec No.

-

Part No.

T-55788GD121J-LW-ACN

Page

2

### 4. Absolute maximum ratings

#### 4-1. Electrical absolute maximum ratings

Item		Symbol	Min.	Max.	Unit
Supply voltage(+3.3V)		V <sub>DD</sub>	-0.3	4.0	V
Supply voltage(+12V)		V <sub>IN</sub>	-0.3	14.0	V
Input signal voltage	RxIN <sub>i</sub> +, RxIN <sub>i</sub> - (i= 0,1,2,3)	V <sub>I1</sub>	-0.3	2.8	V
	CK IN+, CK IN-	V <sub>I2</sub>	-0.3	2.8	V
	SELLVDS	V <sub>I3</sub>	-0.3	V <sub>DD</sub> +0.5	V
	BLBRT, BLEN	V <sub>I4</sub>	-0.3	V <sub>IN</sub>	V

#### 4-2. Environmental absolute maximum ratings

Item	Symbol	Min.	Max.	Unit
Operating temperature 1)	T <sub>OP</sub>	(-30)	(80)	°C
Storage temperature 2)	T <sub>STO</sub>	-30	80	°C
Operating humidity 3)	H <sub>OP</sub>	10	4)	%RH
Storage humidity 3)	H <sub>STO</sub>	10	4)	%RH
Vibration	-	5)	5)	-
Shock	-	6)	6)	-

- 1) Operating temperature means a temperature which operation shall be guaranteed. Since display performance is evaluated at 25°C, another temperature range should be confirmed.
- 2) Temp. = -30°C < 48h , Temp. = 80°C < 168h  
Store LCD at normal temperature/humidity. Keep them free from vibration and shock. An LCD that is kept at a low or a high temperature for a long time can be defective due to other conditions, even if the low or high temperature satisfies the standard.  
(Please refer to "Precautions for Use" for details.)
- 3) Non-condensing
- 4) Temp. ≤ 40°C, 85%RH Max.  
Temp. > 40°C, Absolute humidity shall be less than 85%RH at 40°C.
- 5)

Frequency	10~55 Hz	Acceleration value (0.3~9 m/s <sup>2</sup> )
Vibration width	0.15mm	
Interval	10-55-10 Hz	1 minutes

2 hours in each direction X, Y, Z (6 hours total)

EIAJ ED-2531

- 6) Acceleration: 490 m/s<sup>2</sup>, Pulse width: 11 ms  
3 times in each direction: ±X, ±Y, ±Z  
EIAJ ED-2531

## LCD Module Technical Specification

Spec No.

-

Part No.

T-55788GD121J-LW-ACN

Page

3

### 5. Electrical characteristics

#### 5-1. LCD

Temp. = -20~70°C

Item	Symbol	Condition	Min.	Typ.	Max.	Unit
Supply voltage 1)	$V_{DD}$	-	3.0	3.3	3.6	V
Current consumption	$I_{DD}$	2)	-	TBD	TBD	mA
Permissible input ripple voltage	$V_{RP}$	$V_{DD}=3.3V$	-	-	100	mVp-p
Input signal voltage 3)	$V_{IL}$	"Low" level	0	-	0.8	V
	$V_{IH}$	"High" level	2.0	-	$V_{DD}$	V
Input leak current	$I_{OL}$	$V_{I3}=0V$	-10	-	10	$\mu A$
	$I_{OH}$	$V_{I3}=3.3V$	-	-	400	$\mu A$
LVDS Input voltage 4)	$V_L$	-	0	-	1.9	V
Differential input voltage 4)	$V_{ID}$	-	250	350	450	mV
Differential input threshold voltage 4) 5)	$V_{TL}$	"Low" level	$V_{CM}-100$	-	-	mV
	$V_{TH}$	"High" level	-	-	$V_{CM}+100$	mV
Terminator	$R_1$	-	-	100	-	$\Omega$
$V_{DD}$ -turn-on conditions 1) 6)	t1	-	0.1	-	10	ms
	t2	-	0	-	-	ms
	t3	-	0	-	-	ms
	t4	-	1.0	-	-	s
	t5	-	200	--	-	ms
	t6	-	200	-	-	ms
	t7	-	0	-	10	s
	t8	-	0	-	-	ms

#### 1) $V_{DD}$ -turn-on conditions

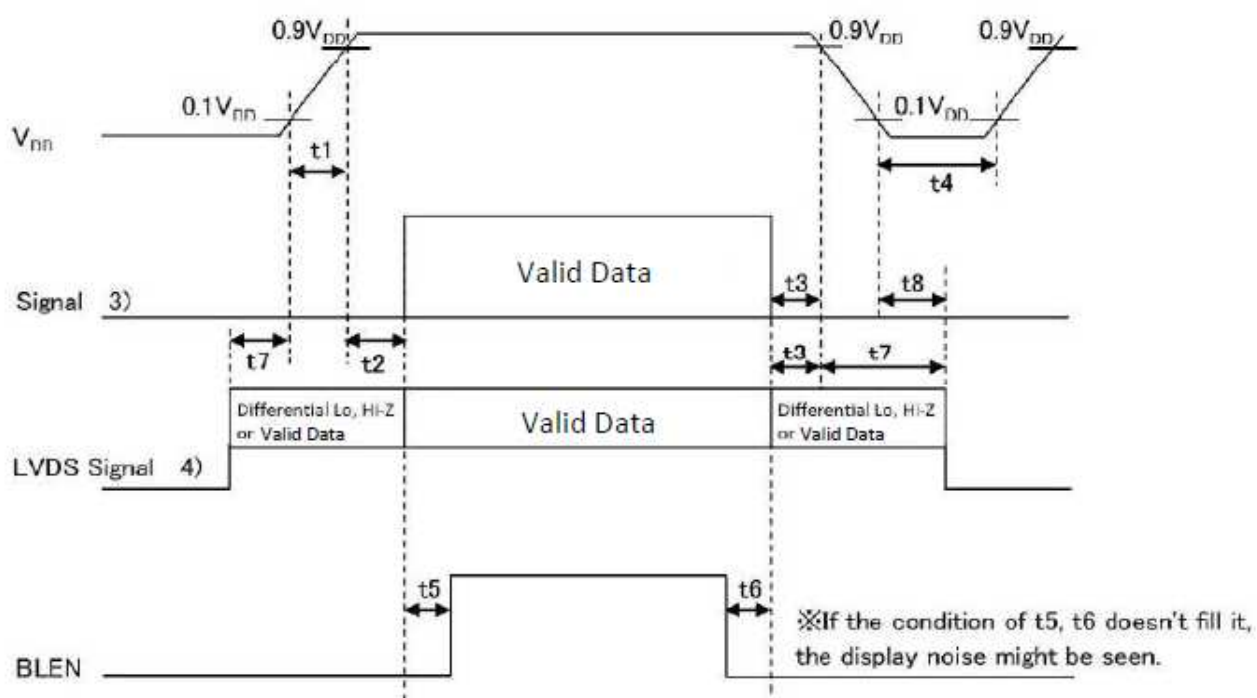

**LCD Module Technical Specification**

Spec No.	—	Part No.	T-55788GD121J-LW-ACN	Page	4
----------	---	----------	----------------------	------	---

2) Display pattern:

$V_{DD} = 3.3V$ , Temp. = 25°C

1 2 3 . . . . . 2398 2399 2400(dot)  
 1  
 2  
 3  
 :  
 :  
 :  
 TBD  
 599  
 600  
 (dot)

3) Input signal : SELVDS

4) Input signal : RxIN3+, RxIN3-, RxIN2+, RxIN2-, RxIN1+, RxIN1-, RxIN0+, RxIN0-  
 CK IN+, CK IN-

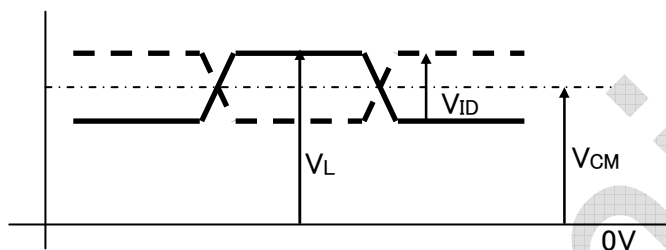

5)  $V_{CM}$  : LVDS Common mode voltage ( $V_{CM}=1.25V$ )

6) Please power on LVDS transmitter at the same time as VDD, or LVDS transmitter should be powered on first.

Preliminary

## LCD Module Technical Specification

Spec No.

-

Part No.

T-55788GD121J-LW-ACN

Page

5

### 5-2. Constant current circuit for LED Backlight

Temp. = -20~70°C

Item	Symbol	Condition	Min.	Typ.	Max.	Unit
Supply voltage 1)	$V_{IN}$	-	10.8	12.0	13.2	V
Current consumption	$I_{IN}$	2)	-	400	-	mA
Permissive input ripple voltage	$V_{RP\_BL}$	$V_{IN}=12.0V$	-	-	100	mVp-p
BLBRT Input signal voltage	$V_{IL\_BLBRT}$	"Low" level	0	-	0.8	V
	$V_{IH\_BLBRT}$	"High" level	2.3	-	$V_{IN}$	V
BLBRT Input pull-down resistance	$R_{IN\_BLBRT}$	-	100	300	500	k $\Omega$
BLEN Input signal voltage	$V_{IL\_BLEN}$	"Low" level	0	-	0.8	V
	$V_{IH\_BLEN}$	"High" level	2.3	-	$V_{IN}$	V
BLEN Input pull-down resistance	$R_{IN\_BLEN}$	-	100	300	500	k $\Omega$
P W M Frequency 3)	$f_{PWM}$	-	200	-	10k	Hz
P W M Duty ratio 3)	$D_{PWM}$	$f_{PWM}=200Hz$	1	-	100	%
		$f_{PWM}=2kHz$	10	-	100	%
		$f_{PWM}=10kHz$	50	-	100	%
Operating life time 4), 5)	T	Temp.=25°C	-	(75,000)	-	h

### 【LED Circuit】

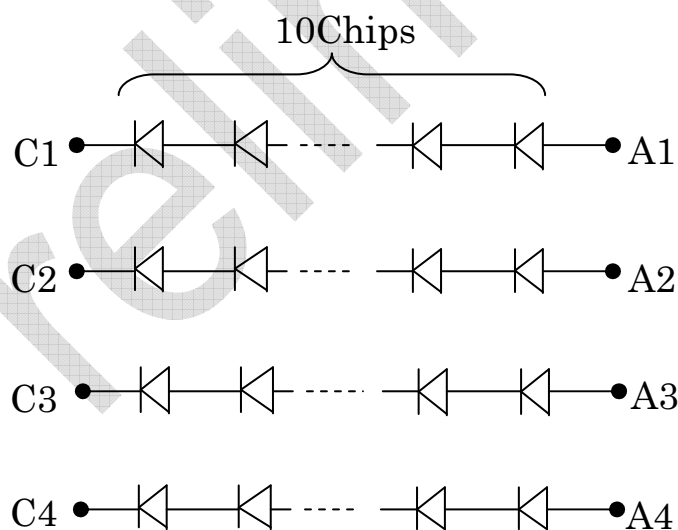

## LCD Module Technical Specification

Spec No.

-

Part No.

T-55788GD121J-LW-ACN

Page

6

### 1) $V_{IN}$ -turn-on conditions

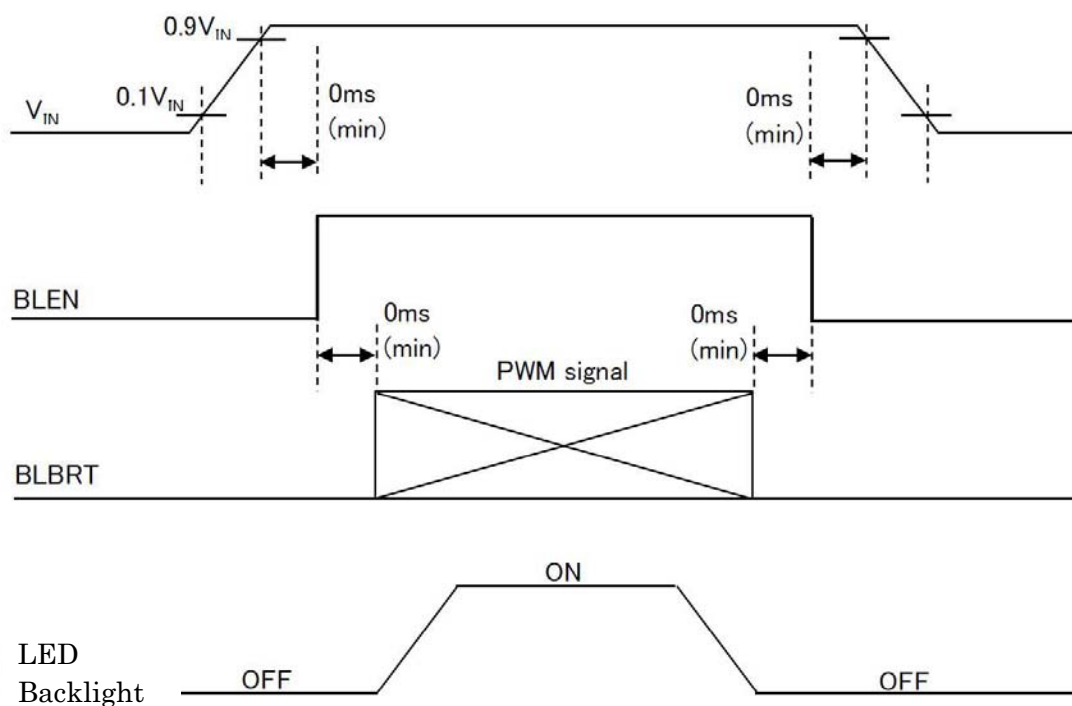

### 2) $V_{IN} = 12V$ , Temp. = $25^{\circ}C$ , $D_{PWM} = 100\%$

### 3) PWM Timing Diagram

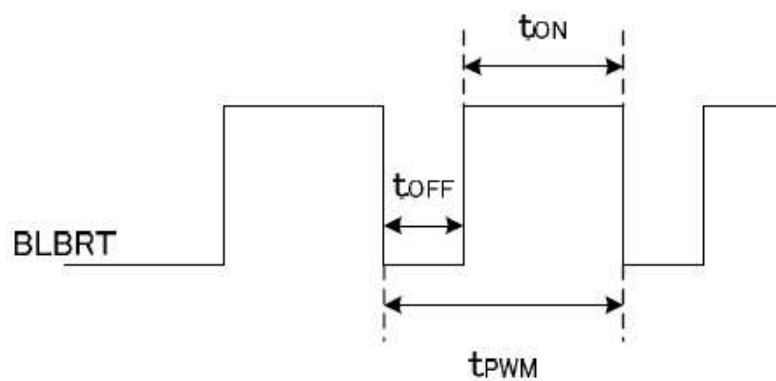

$$t_{ON}, t_{OFF} \geq 50 \mu s.$$

In case of lower frequency, the deterioration of the display quality, flicker etc., may occur.

### 4) When brightness decrease 50% of minimum brightness. The average life of a LED will decrease when the LCD is operating at higher temperatures.

### 5) Life time is estimated data.(Condition : $I_F=60mA$ , $T_a=25^{\circ}C$ in chamber).

## LCD Module Technical Specification

Spec No.

-

Part No.

T-55788GD121J-LW-ACN

Page

7

### 6. Optical characteristics

Measuring spot =  $\phi$  6.0mm, Temp. = 25°C

Item	Symbol	Condition	Min.	Typ.	Max.	Unit	
Response time	Rise	$\tau_r$	$\theta = \phi = 0^\circ$	-	(18)	-	ms
	Down	$\tau_d$	$\theta = \phi = 0^\circ$	-	(12)	-	ms
Viewing angle range	$\theta$ UPPER	CR $\geq$ 10	-	(85)	-	deg.	
	$\theta$ LOWER		-	(85)	-		
	$\phi$ LEFT		-	(85)	-	deg.	
	$\phi$ RIGHT		-	(85)	-		
Contrast ratio	CR	$\theta = \phi = 0^\circ$	(500)	(850)	-	-	
Brightness	L	IF=100mA/Line	-	(1200)	-	cd/m <sup>2</sup>	
Chromaticity coordinates	Red	x	$\theta = \phi = 0^\circ$	(0.551)	(0.601)	(0.651)	-
		y		(0.294)	(0.344)	(0.394)	
	Green	x	$\theta = \phi = 0^\circ$	(0.302)	(0.352)	(0.402)	
		y		(0.509)	(0.559)	(0.609)	
	Blue	x	$\theta = \phi = 0^\circ$	(0.099)	(0.149)	(0.199)	
		y		(0.074)	(0.124)	(0.174)	
	White	x	$\theta = \phi = 0^\circ$	(0.272)	(0.322)	(0.372)	
		y		(0.294)	(0.344)	(0.394)	

#### 6-1. Definition of contrast ratio

$$\text{CR(Contrast ratio)} = \frac{\text{Brightness with all pixels "White"}}{\text{Brightness with all pixels "Black"}}$$

#### 6-2. Definition of response time

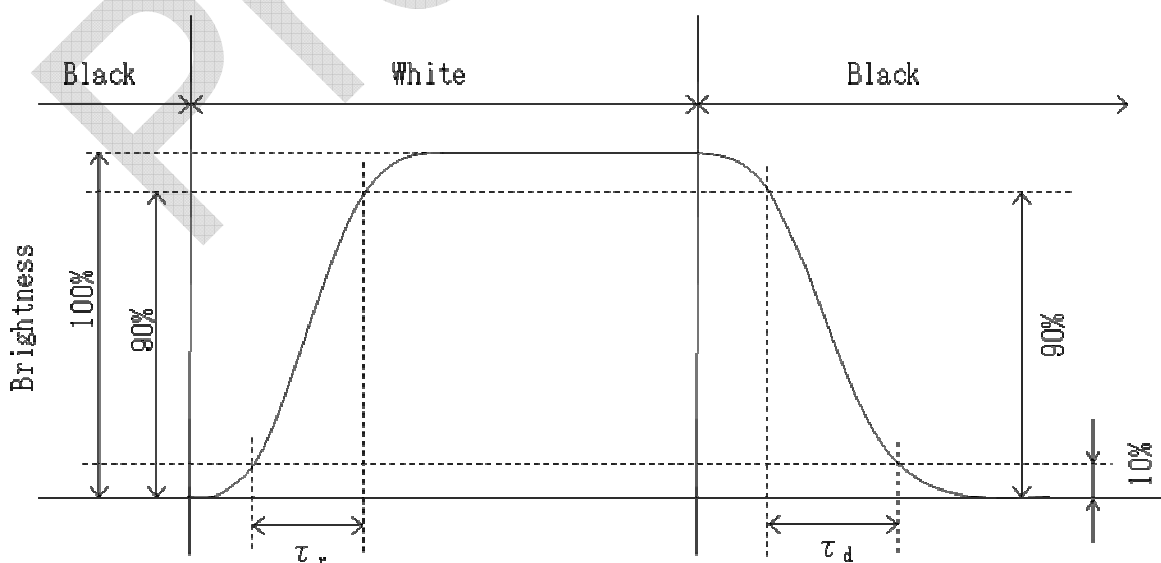

## LCD Module Technical Specification

Spec No.

-

Part No.

T-55788GD121J-LW-ACN

Page

8

### 6-3. Definition of viewing angle

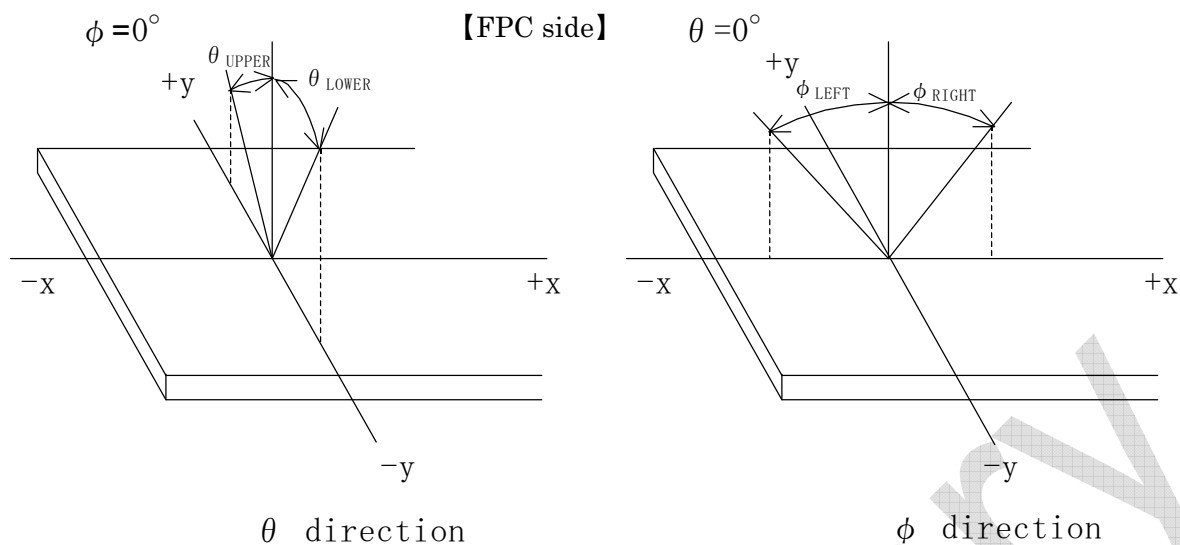

### 6-4. Brightness measuring points

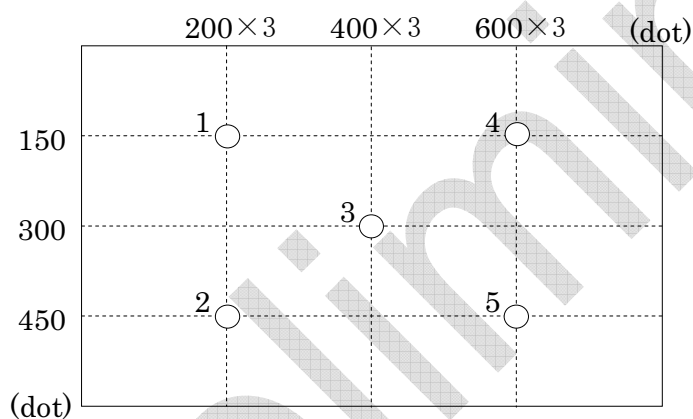

- 1) Rating is defined as the white brightness at center of display screen(3).
- 2) 5 minutes after LED is turned on. (Ambient Temp.=25°C)



**LCD Module Technical Specification**

Spec No.

-

Part No.

T-55788GD121J-LW-ACN

Page

9

**7. Interface signals**

## 7-1. Interface signals

No.	Symbol	Description	Note
1	GND	GND	
2	SELLVDS	Mode select signal(LVDS Data mapping)	
3	GND	GND	
4	GND	GND	
5	RxIN3+	LVDS receiver signal CH3(+)	LVDS
6	RxIN3-	LVDS receiver signal CH3(-)	LVDS
7	GND	GND	
8	CK IN+	LVDS receiver signal CK(+)	LVDS
9	CK IN-	LVDS receiver signal CK(-)	LVDS
10	GND	GND	
11	RxIN2+	LVDS receiver signal CH2(+)	LVDS
12	RxIN2-	LVDS receiver signal CH2(-)	LVDS
13	GND	GND	
14	RxIN1+	LVDS receiver signal CH1(+)	LVDS
15	RxIN1-	LVDS receiver signal CH1(-)	LVDS
16	GND	GND	
17	RxIN0+	LVDS receiver signal CH0(+)	LVDS
18	RxIN0-	LVDS receiver signal CH0(-)	LVDS
19	GND	GND	
20	GND	GND	
21	V <sub>DD</sub>	+3.3V power supply	
22	V <sub>DD</sub>	+3.3V power supply	
23	GND	GND	
24	BLBRT	PWM signal(Brightness adjustment)	
25	BLEN	ON/OFF terminal voltage	
26	GND	GND	
27	V <sub>IN</sub>	+12V power supply	
28	V <sub>IN</sub>	+12V power supply	
29	GND	GND	
30	GND	GND	

LCD connector : FI-X30SSLA-HF (JAE)

Matching connector : FI-X30HL (JAE)

: FI-X30HL-T (JAE)

: FI-X30C2L-NPB (JAE)

: FI-X30C2L-T-NPB (JAE)

LVDS receiver : Embedded in ASIC

Matching LVDS transmitter : THC63LVDM83R(THine Electronics) or compatible

## LCD Module Technical Specification

Spec No.

-

Part No.

T-55788GD121J-LW-ACN

Page

10

### 7-2. Data mapping(6bit RGB input)

#### 1) Location of SELLVDS (THC63LVDM83R(THine Electronics) or compatible)

Transmitter		2Pin SELLVDS	
Pin No.	Data	= L(GND) or OPEN	= H(3.3V)
51	TA0	—	R0(LSB)
52	TA1	—	R1
54	TA2	—	R2
55	TA3	—	R3
56	TA4	—	R4
3	TA5	—	R5(MSB)
4	TA6	—	G0(LSB)
6	TB0	—	G1
7	TB1	—	G2
11	TB2	—	G3
12	TB3	—	G4
14	TB4	—	G5(MSB)
15	TB5	—	B0(LSB)
19	TB6	—	B1
20	TC0	—	B2
22	TC1	—	B3
23	TC2	—	B4
24	TC3	—	B5(MSB)
27	TC4	—	(HS)
28	TC5	—	(VS)
30	TC6	—	DE
50	TD0	—	GND
2	TD1	—	GND
8	TD2	—	GND
10	TD3	—	GND
16	TD4	—	GND
18	TD5	—	GND
25	TD6	—	GND

SELLVDS=H(3.3V)

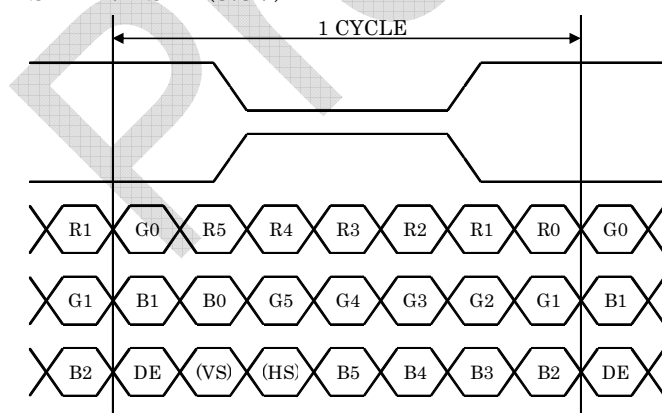

DE : DATA ENABLE

HS : H<sub>SYNC</sub>

VS : V<sub>SYNC</sub>

## LCD Module Technical Specification

Spec No.

-

Part No.

T-55788GD121J-LW-ACN

Page

11

### 2) Block Diagram

SELLVDS=H(3.3V)

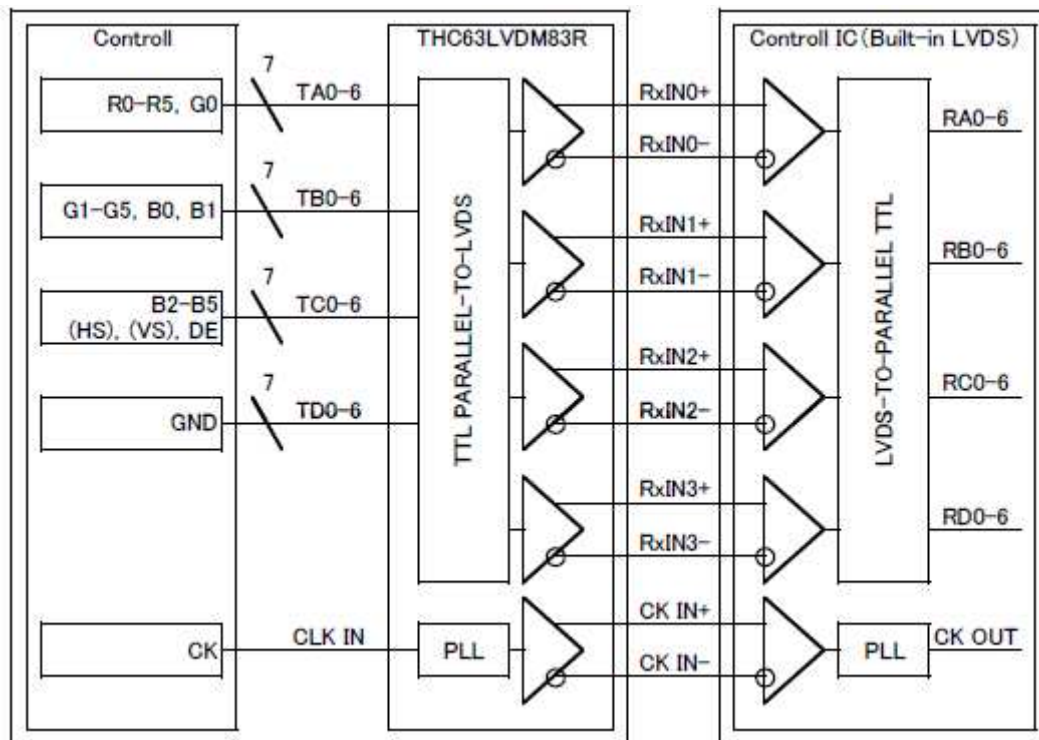

When using “6-bit Transmitter”, please connect the unused channel of the control IC receiver as described in the diagram below.

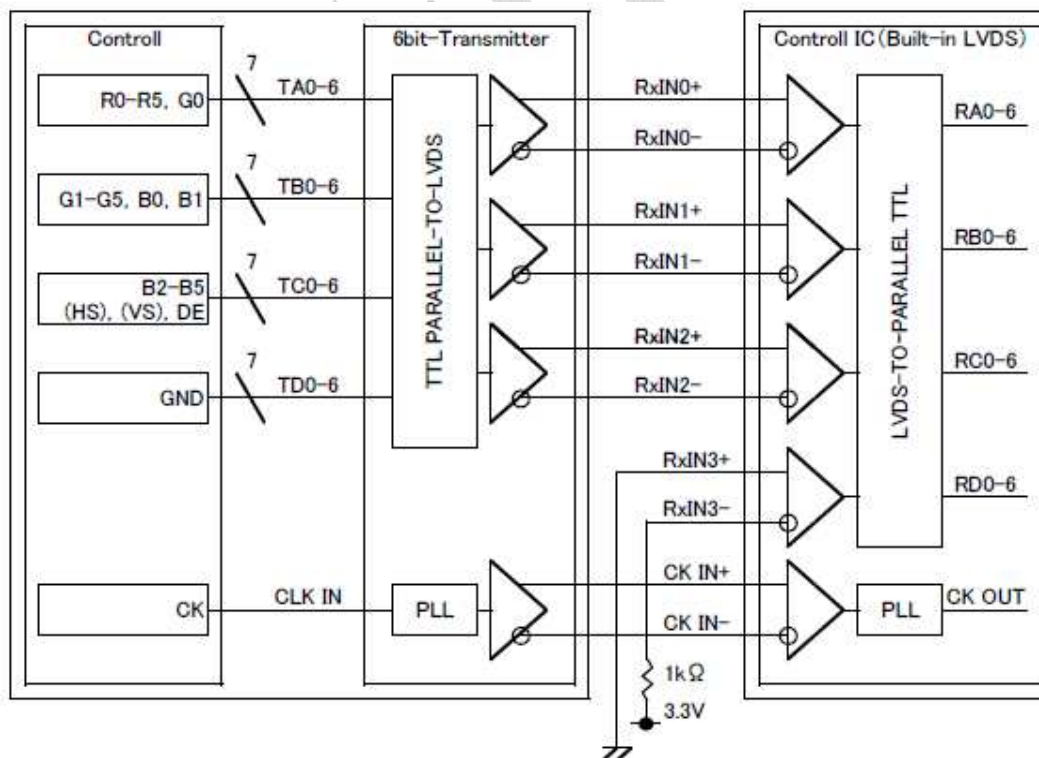

## LCD Module Technical Specification

Spec No.

-

Part No.

T-55788GD121J-LW-ACN

Page

12

### 7-3. Data mapping(8bit RGB input)

#### 1) Location of SELLVDS (THC63LVDM83R(THine Electronics) or compatible)

Transmitter		2Pin SELLVDS	
Pin No.	Data	= L(GND) or OPEN	= H(3.3V)
51	TA0	R0(LSB)	R2
52	TA1	R1	R3
54	TA2	R2	R4
55	TA3	R3	R5
56	TA4	R4	R6
3	TA5	R5	R7(MSB)
4	TA6	G0(LSB)	G2
6	TB0	G1	G3
7	TB1	G2	G4
11	TB2	G3	G5
12	TB3	G4	G6
14	TB4	G5	G7(MSB)
15	TB5	B0(LSB)	B2
19	TB6	B1	B3
20	TC0	B2	B4
22	TC1	B3	B5
23	TC2	B4	B6
24	TC3	B5	B7(MSB)
27	TC4	(HS)	(HS)
28	TC5	(VS)	(VS)
30	TC6	DE	DE
50	TD0	R6	R0(LSB)
2	TD1	R7(MSB)	R1
8	TD2	G6	G0(LSB)
10	TD3	G7(MSB)	G1
16	TD4	B6	B0(LSB)
18	TD5	B7(MSB)	B1
25	TD6	(NA)	(NA)

SELLVDS=L(GND) or OPEN

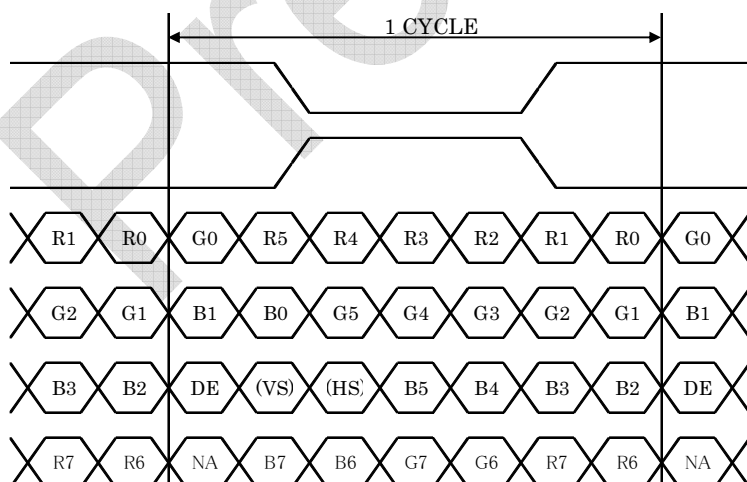

DE : DATA ENABLE

HS : H<sub>SYNC</sub>

VS : V<sub>SYNC</sub>

**LCD Module Technical Specification**

Spec No.

—

Part No.

T-55788GD121J-LW-ACN

Page

13

SELLVDS=H(3.3V)

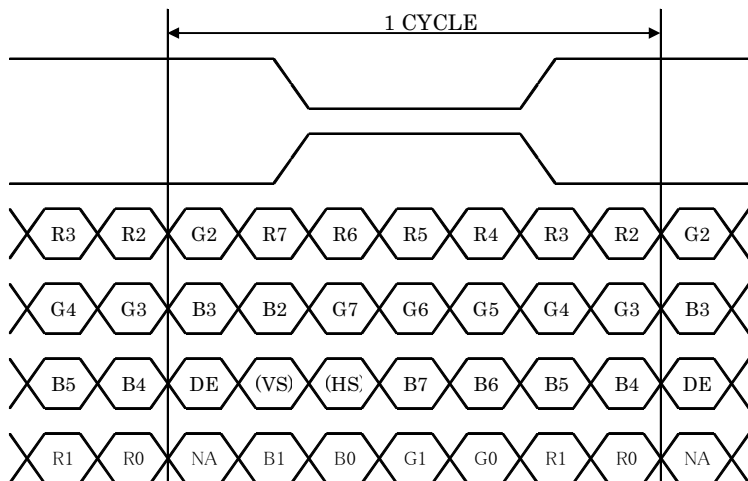

DE : DATA ENABLE

HS : Hsync

VS : Vsync

2) Block Diagram

SELLVDS=L(GND) or OPEN

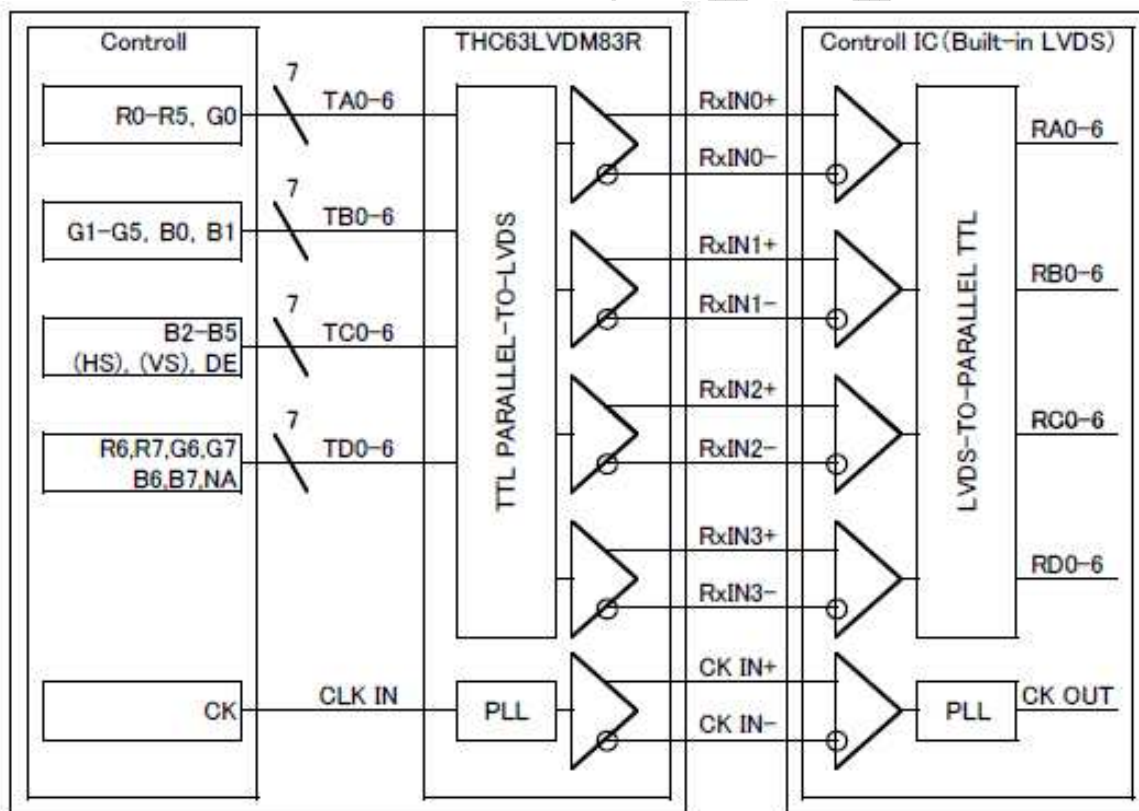

# LCD Module Technical Specification

Spec No.

-

Part No.

T-55788GD121J-LW-ACN

Page

14

SELLVDS=H(3.3V)

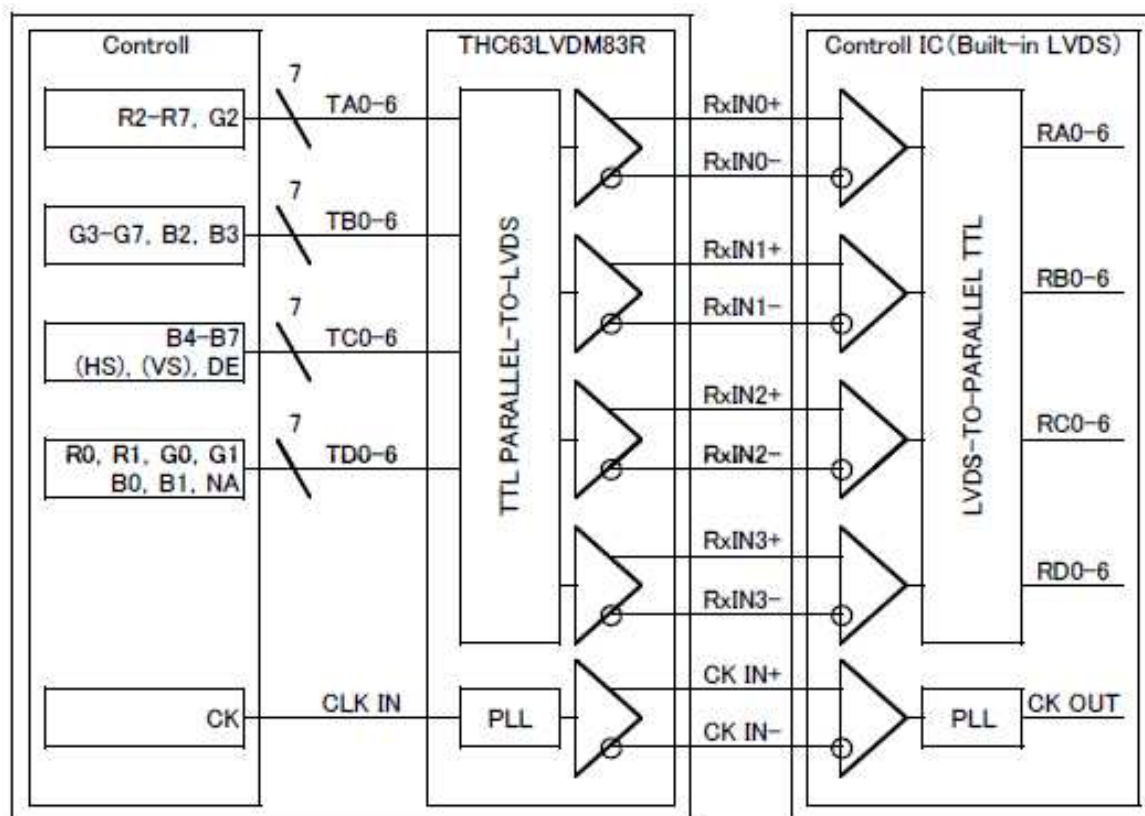

## LCD Module Technical Specification

Spec No.

-

Part No.

T-55788GD121J-LW-ACN

Page

15

## 8. Input timing characteristics

### 8-1. Timing characteristics

Item		Symbol	Min.	Typ.	Max.	Unit	Note
Clock (CK)	Frequency	1/Tc	30	40	48	MHz	
Enable signal (DE)	Horizontal Period	Th	860	1056	1395	Tc	
			24.0	26.4	-	$\mu s$	1)
	Horizontal display period	Thd	800			Tc	
	Vertical Period	Tv	610	628	1024	Th	
	Vertical display period	Tvd	600			Th	
Refresh rate		fv	50	60	70	Hz	2)

- 1) Please set a clock frequency, a vertical dormant period, and the horizontal dormant period so that the Horizontal Period should not reach less than Min. value.
- 2) If the refresh rate reach less than Min. value, the deterioration of the display quality, flicker etc., may occur. ( $fv=1/Tv$ )

#### Vertical Timing Diagram

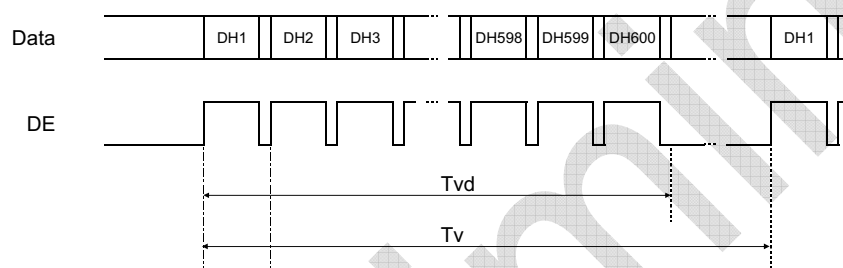

#### Horizontal Timing Diagram

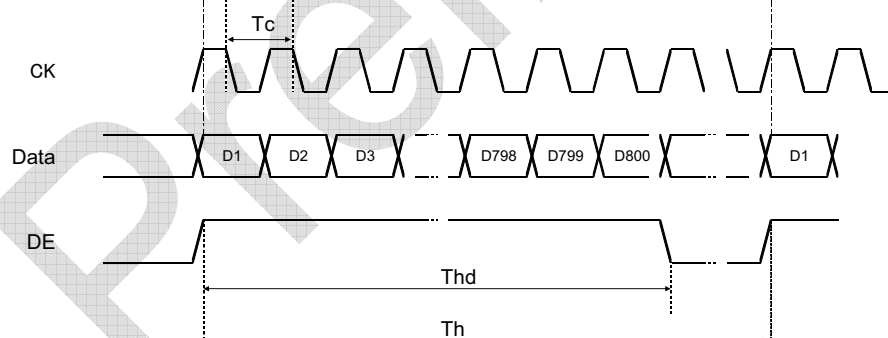

### 8-2. Input Data Signals and Display position on the screen

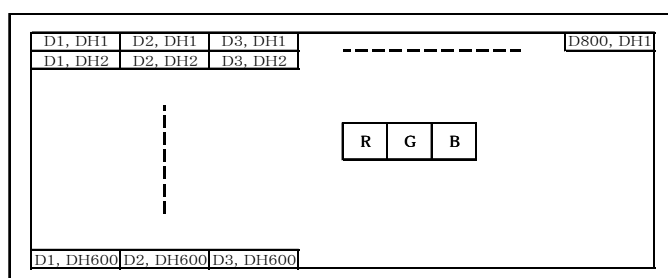

**LCD Module Technical Specification**

Spec No.

-

Part No.

T-55788GD121J-LW-ACN

Page

16

**9. Reliability test data**

Test item	Test condition	Test time	Judgement
High temp. atmosphere	80°C	(240h)	Display function : No defect Display quality : No defect Current consumption : No defect
Low temp. atmosphere	-30°C	(240h)	Display function : No defect Display quality : No defect Current consumption : No defect
High temp. humidity atmosphere	40°C 90% RH	(240h)	Display function : No defect Display quality : No defect Current consumption : No defect
Temp. cycle	-30°C 0.5h R.T. 0.5h 80°C 0.5h	(10cycles)	Display function : No defect Display quality : No defect Current consumption : No defect
High temp. operation	70°C	(500h)	Display function : No defect Display quality : No defect Current consumption : No defect

- 1) Each test item uses a test LCD only once. The tested LCD is not used in any other tests.
- 2) The LCD is tested in circumstances in which there is no condensation.
- 3) The reliability test is not an out-going inspection.
- 4) The result of the reliability test is for your reference purpose only.  
The reliability test is conducted only to examine the LCD's capability.

**10. Code System of Production Lot**

The production lot of module is specified as follows.

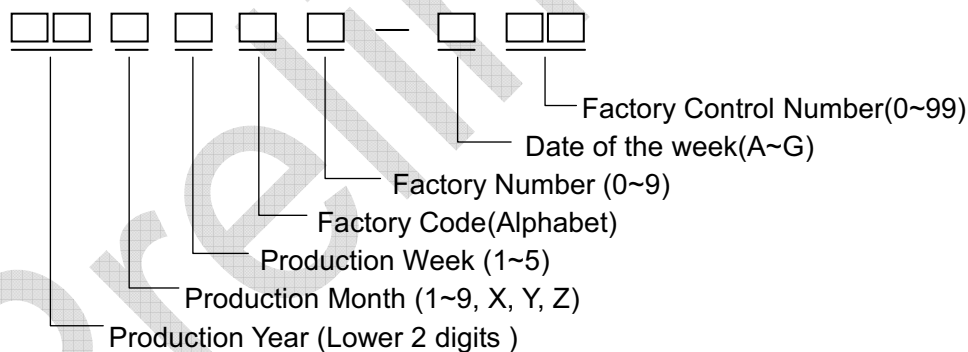
**11. Type Code Number**

The type Code number of module is specified as follows.

355788AC

**12. Applying Precautions**

Please contact us when questions and/or new problems not specified in this Specifications arise.



**LCD Module Technical Specification**

Spec No.

-

Part No.

T-55788GD121J-LW-ACN

Page

17

**13. Precautions Relating Product Handling**

The Following precautions will guide you in handling our product correctly.

## 1) Liquid crystal display devices

- (1) The liquid crystal display panel used in the liquid crystal display module is made of plate glass. Avoid any strong mechanical shock. Should the glass break handle it with care.
- (2) The polarizer adhering to the surface of the LCD is made of a soft material.  
Guard against scratching it.

## 2) Care of the liquid crystal display module against static electricity discharge.

- (1) When working with the module, be sure to ground your body and any electrical equipment you may be using. We strongly recommend the use of anti static mats (made of rubber), to protect worktables against the hazards of electrical shock.
- (2) Slowly and carefully remove the protective film from the LCD module, since this operation can generate static electricity.

## 3) When the LCD module alone must be stored:

- (1) Protect the modules from high temperature and humidity.  
"Recommended storage conditions" Temperature: 0~30°C, Humidity: 60~70%RH,  
No dew condensation to be observed.
- (2) Keep the modules out of direct sunlight or direct exposure to ultraviolet rays.
- (3) Protect the modules from excessive external forces.

## 4) Use the module with a power supply that is equipped with an overcurrent protector circuit, since the module is not provided with this protective feature.

5) Do not ingest the LCD fluid itself should it leak out of a damaged LCD module.  
Should hands or clothing come in contact with LCD fluid, wash immediately with soap.

## 6) Conductivity is not guaranteed for models that use metal holders where solder connections between the metal holder and the PCB are not used. Please contact us to discuss appropriate ways to assure conductivity.

## 7) For models which use COG, TCP, or COF:

- (1) The mechanical strength of the product is low since the IC chip faces out unprotected from the rear. Be sure to protect the rear of the IC chip from external forces.
- (2) Given the fact that the rear of the IC chip is left exposed, in order to protect the unit from electrical damage, avoid installation configurations in which the rear of the IC chip runs the risk of making any electrical contact.

## 8) Models which use flexible cable, heat seal, or TCP:

- (1) In order to maintain reliability, do not touch or hold by the connector area.
- (2) Avoid any bending, pulling, or other excessive force, which can result in broken connections.

## 9) In case of buffer material such as cushion / gasket is assembled into LCD module, it may have an adverse effect on connecting parts ( LCD panel-TCP / HEAT SEAL / FPC / etc., PCB-TCP / HEAT SEAL / FPC etc., TCP-HEAT SEAL, TCP-FPC, HEAT SEAL-FPC, etc.,) depending on its materials. Please check and evaluate these materials carefully before use.

**LCD Module Technical Specification**

Spec No.

—

Part No.

T-55788GD121J-LW-ACN

Page

18

- 10) In case of acrylic plate is attached to front side of LCD panel, cloudiness (very small cracks) can occur on acrylic plate, being influenced by some components generated from polarizer film. Please check and evaluate those acrylic materials carefully before use.
- 11) Flickering due to optical interference may occur by combination of a) LCD driving frame frequency decided by either internal oscillator in driver IC or external clock input by the customer and b) lighting frequency of either backlight or other light sources. Please evaluate enough at the environment of actual use, and decide the driving condition that does not cause flickering.
- 12) Please be advised that do not apply Direct Current (DC) voltage to the LCD. If DC voltage is applied to the LCD, then it may cause poor display quality.
- 13) Notes of the packing tray  
Please pile up the packing tray in the designated described in the packaging specification because the piling method is different according to the product shape. Moreover, please don't pile up more than the number of the trays given in a packaging specification. The wrong way of piling up of the trays and piling up by excessive numbers of the trays may cause the damages such as dent and glass crack on the products.

**14. Warranty**

This product has been manufactured to your company's specifications as a part for use in your company's general electronic products. It is guaranteed to perform according to delivery specifications. For any other use apart from general electronic equipment, we cannot take responsibility if the product is used in medical devices, nuclear power control equipment, aerospace equipment, fire and security systems, or any other applications in which there is a direct risk to human life and where extremely high levels of reliability are required. If the product is to be used in any of the above applications, we will need to enter into a separate product liability agreement.

- 1) We cannot accept responsibility for any defect, which may arise from additional manufacturing of the product (including disassembly and reassembly), after product delivery.
- 2) We cannot accept responsibility for any defect, which may arise after the application of strong external force to the product.
- 3) We cannot accept responsibility for any defect, which may arise due to the application of static electricity after the product has passed your company's acceptance inspection procedures.
- 4) We cannot accept responsibility for intellectual property of a third party, which may arise through the application of our product to your assembly with exception to those issues relating directly to the structure or method of manufacturing of our product.
- 5) Kyocera Display will not be held responsible for any quality guarantee issue for defect products judged as Kyocera Display-origin in 2 (two) years from Kyocera Display production or 1(one) year from Kyocera Display Group delivery which ever is shorter.