

## Features

- Transient protection for high-speed data lines
  - IEC 61000-4-2 (ESD)  $\pm 27\text{kV}$  (Air)
  - $\pm 17\text{kV}$  (Contact)
  - IEC 61000-4-4 (EFT) 40A (5/50 ns)
  - Cable Discharge Event (CDE)
- Small package (2.9mm u 2.8mm u 1.4mm)
- Protects four data lines
- Low capacitance: 0.3pF Typical (I/O-I/O)
- Low leakage current: 0.1uA@V<sub>RWM</sub> (Typical)
- Low clamping voltage
- Each I/O pin can withstand over 1000 ESD strikes for  $\pm 8\text{kV}$  contact discharge

## Description

T0514TL is an ultra-low capacitance Transient Voltage Suppressor (TVS) designed to provide electrostatic discharge (ESD) protection for high-speed data interfaces. With typical capacitance of 0.3pF only, T0514TL is designed to protect parasitic-sensitive system against over-voltage and over-current transient events. It complies with IEC61000-4-2(ESD) ,Level 4 ( $\pm 15\text{kV}$  air, $\pm 8\text{kV}$  contact discharge),IEC 61000-4-4 (electrical fast transient - EFT) (40A,5/50ns) , very fast charged device model (CDM)ESD and cable discharge event (CDE),etc.

T0514TL user small SOT23-6L package. Each T0514TL device can protect four high-speed data lines. The combined features of low capacitance, small size and high ESD robustness make T0514TL ideal for high-speed data ports and high-frequency lines (e.g., HDMI & DVI) applications. The low clamping voltage of the T0514 TL guarantees a minimum stress on the protected IC.

## Applications

- Serial ATA
- PCI Express
- Desktops, Servers and Notebooks
- MDDI Ports
- USB 2.0/3.0 Power and Data Line Protection
- Display Ports
- High Definition Multi-Media Interface (HDMI)
- Digital Visual Interfaces (DVI)

## Mechanical Characteristics

- SOT23-6L package
- Flammability Rating: UL 94V-0
- Packaging: Tape and Reel

## Circuit Diagram

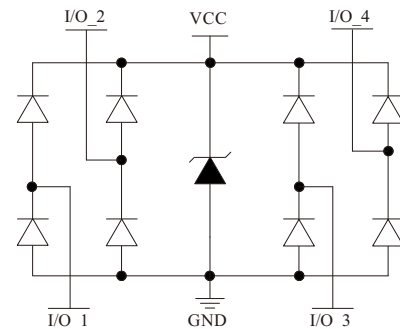

## Pin Configuration

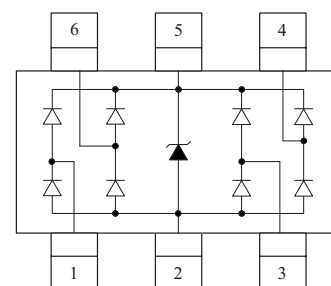

SOT23-6L  
(Top View)

### Absolute Maximum Rating

Symbol	Parameter	Value	Units
$V_{ESD}$	ESD per IEC 61000-4-2 (Air)	$\pm 27$	kV
	ESD per IEC 61000-4-2 (Contact)	$\pm 17$	
$T_{OPT}$	Operating Temperature	-55/+125	$^{\circ}C$
$T_{STG}$	Storage Temperature	-55/+150	$^{\circ}C$

### Electrical Characteristics (T = 25 $^{\circ}C$ )

Symbol	Parameter
$V_{RWM}$	Nominal Reverse Working Voltage
$I_R$	Reverse Leakage Current @ $V_{RWM}$
$V_{BR}$	Reverse Breakdown Voltage @ $I_T$
$I_T$	Test Current for Reverse Breakdown
$V_C$	Clamping Voltage @ $I_{PP}$
$I_{PP}$	Maximum Peak Pulse Current
$C_{ESD}$	Parasitic Capacitance
$V_R$	Reverse Voltage
f	Small Signal Frequency
$I_F$	Forward Current
$V_F$	Forward Voltage @ $I_F$

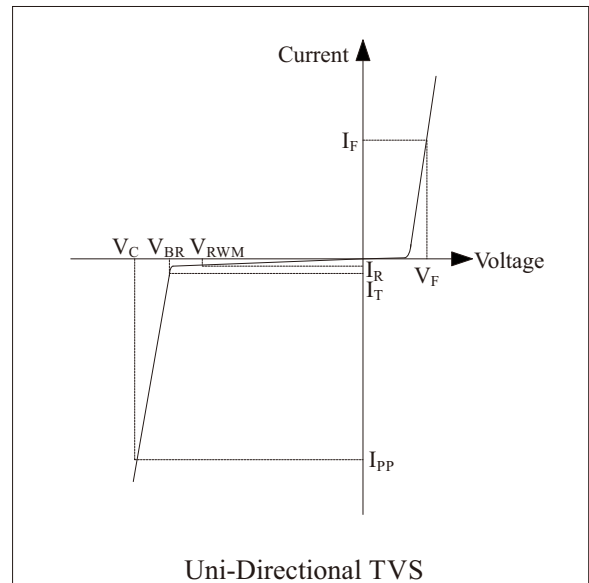

Symbol	Test Condition	Minimum	Typical	Maximum	Units
$V_{RWM}$				5.0	V
$I_R$	$V_{RWM} = 5V, T = 25^{\circ}C$ Between I/O and GND		0.1	1.0	$\mu A$
$V_{BR}$	$I_T = 1mA$ Between I/O and GND	6.0	8.0	10.0	V
$V_C$	$I_{PP} = 1A, t_p = 8/20\mu s$ Between I/O and GND			12.0	V
$C_{ESD}$	$V_R = 0V, f = 1MHz$ Between I/O and GND		0.6	0.8	pF
$C_{ESD}$	$V_R = 0V, f = 1MHz$ Between I/O and I/O		0.3	0.4	pF

**Voltage Sweeping of I/O to GND**

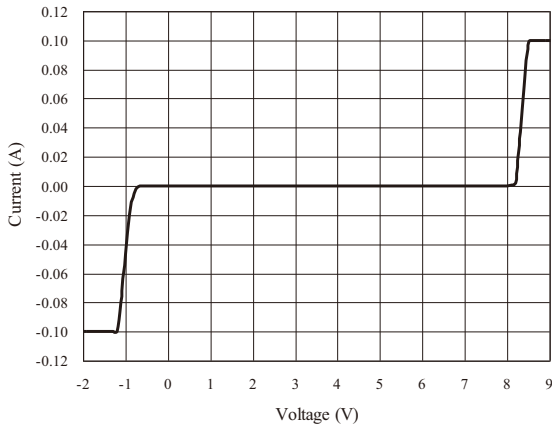

**Insertion Loss S21 of I/O to GND**

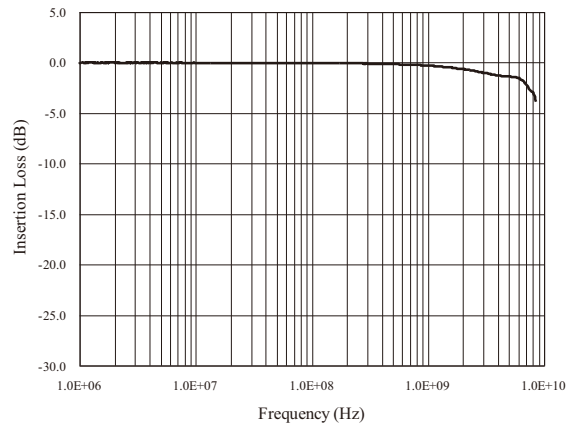

**Capacitance vs. Voltage of I/O to GND (f = 1MHz)**

Capacitance vs. Reverse Voltage

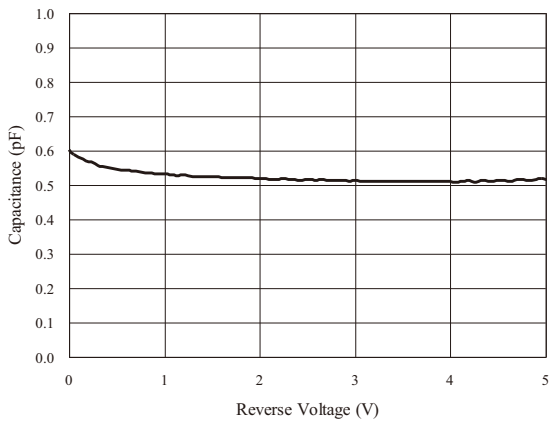

Normalized Capacitance vs. Reverse Voltage

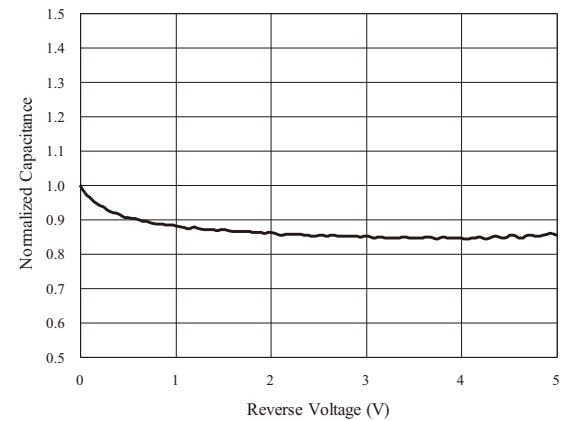

**ESD Clamping of I/O to GND (+8kV Contact per IEC 61000-4-2)**

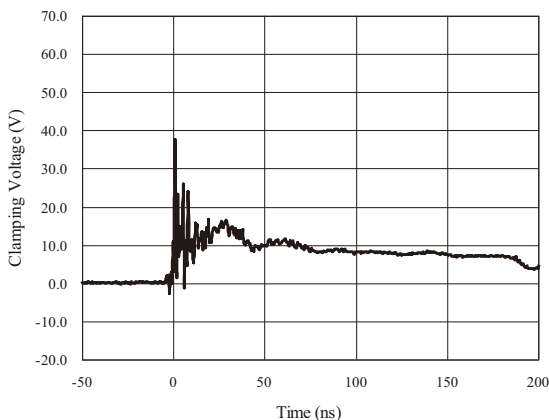

**ESD Clamping of I/O to GND (-8kV Contact per IEC 61000-4-2)**

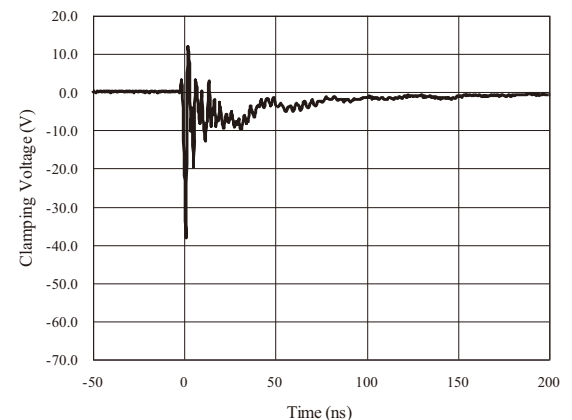

## Application Information

### Pin Connection in PCB

T0514TL is capable to provide ESD protection for four data lines simultaneously. The pin connection is shown in Figure 1.

Four parallel data lines, from inner IC to I/O port connector, could connect to T0514TL four I/O pins directly. Pin 2 of T0514TL is the negative reference pin, which should connect to the GND of PCB. The connection wires should be as short as possible in order to minimize the parasitic inductance.

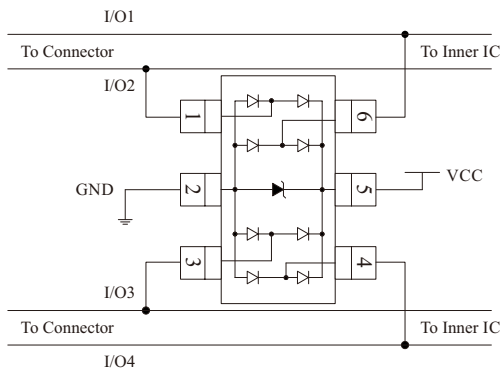

Figure 1 T0514TL pin connection in PCB

### PCB Layout Guidelines

For optimum ESD protection and the whole circuit performance, the following PCB layout guidelines are recommended:

T0514TL GND pin to the PCB GND rail path should be as short as possible. It could reduce the ESD transient return path to GND.

The vias connecting T0514TL VCC & GND pins to the PCB VCC & GND should be wide.

Place T0514TL as close to the connector port as possible. It could reduce the parasitic inductance and restrict ESD coupling into adjacent traces.

Avoid running critical signals near board edges.

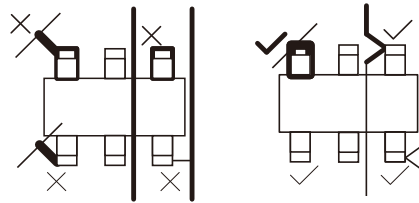
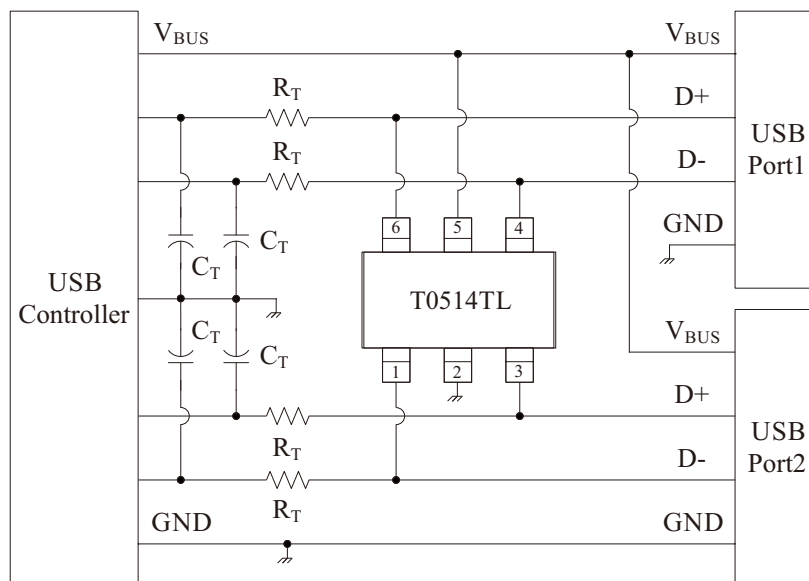
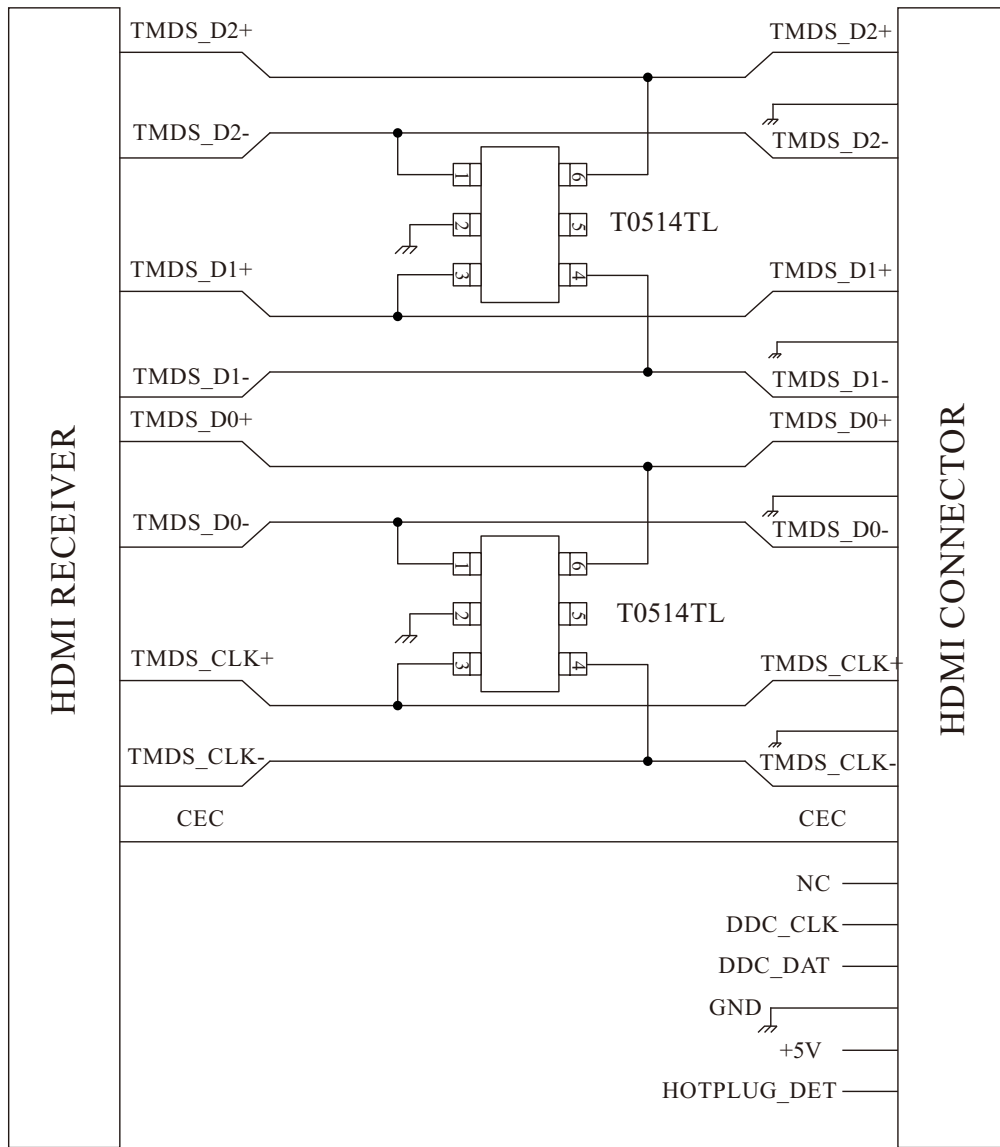

Figure 2 T0514TL Layout Guideline

## Universal Serial Bus ESD Protection



## Application Information (continued)



Layout Top View for HDMI Interface with T0514TL

### Package Outline

SOT23-6L package

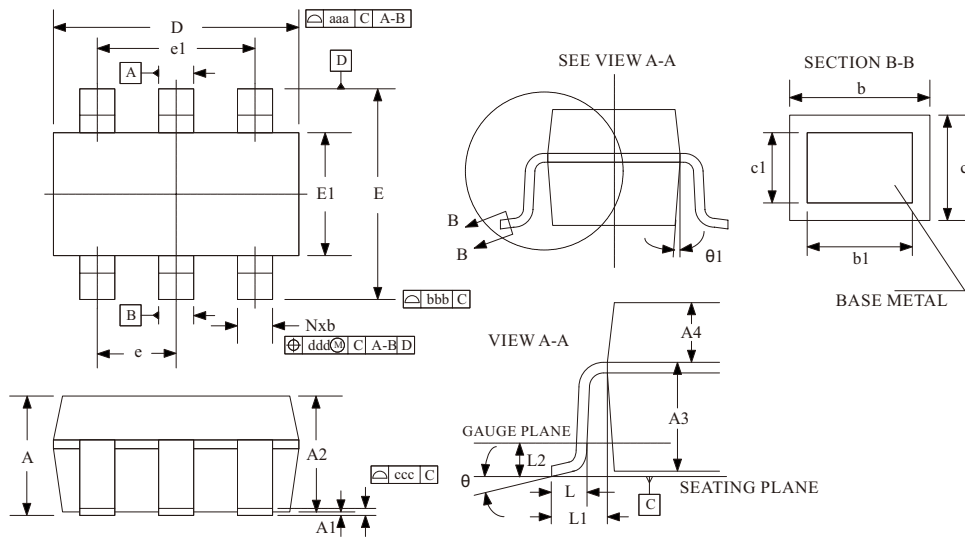

Package Dimensions (Controlling dimensions are in millimeters)

Symbol	Dimensions (mm)			Dimensions (Inches)		
	Minimum	Typical	Maximum	Minimum	Typical	Maximum
A	---	---	1.450	---	---	0.057
A1	0.000	---	0.150	0.000	---	0.006
A2	0.900	1.200	1.300	0.035	0.047	0.012
A3	0.637	0.787	0.837	0.025	0.031	0.033
A4	0.263	0.413	0.463	0.010	0.016	0.018
b	0.300	---	0.500	0.012	---	0.020
b1	0.300	0.400	0.450	0.012	0.016	0.018
c	0.080	---	0.220	0.003	---	0.009
c1	0.080	0.130	0.200	0.003	0.005	0.008
D	2.90 BSC			0.114 BSC		
e	0.95 BSC			0.037 BSC		
e1	1.90 BSC			0.075 BSC		
E	2.80 BSC			0.110 BSC		
E1	1.60 BSC			0.063 BSC		
L	0.300	0.450	0.600	0.012	0.018	0.024
L1	0.600 REF			0.024 REF		
L2	0.250 BSC			0.010 BSC		
theta	0°	4°	8°	0°	4°	8°
theta1	5°	10°	15°	5°	10°	15°
aaa	0.150			0.006		
bbb	0.200			0.008		
ccc	0.100			0.004		
ddd	0.100			0.004		

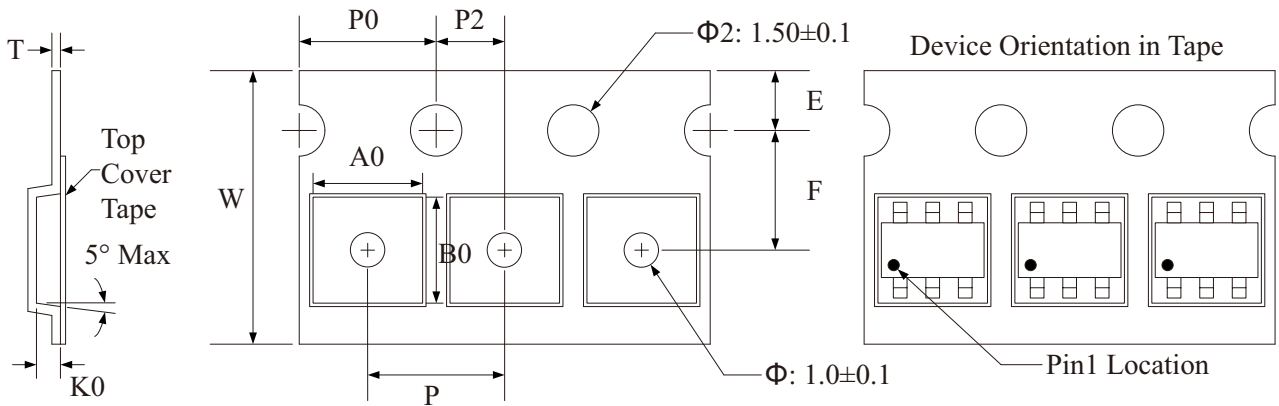
**Tape and Reel Specification**

Symbol	W	A0	B0	K0	E	F	P	P0	P2	T
Dimensions (mm)	8.00+0.3 -0.1	3.23±0.05	3.17±0.05	1.37±0.05	1.75±0.1	3.5±0.05	4.0±0.1	4.0±0.1	2.0±0.05	0.25±0.02

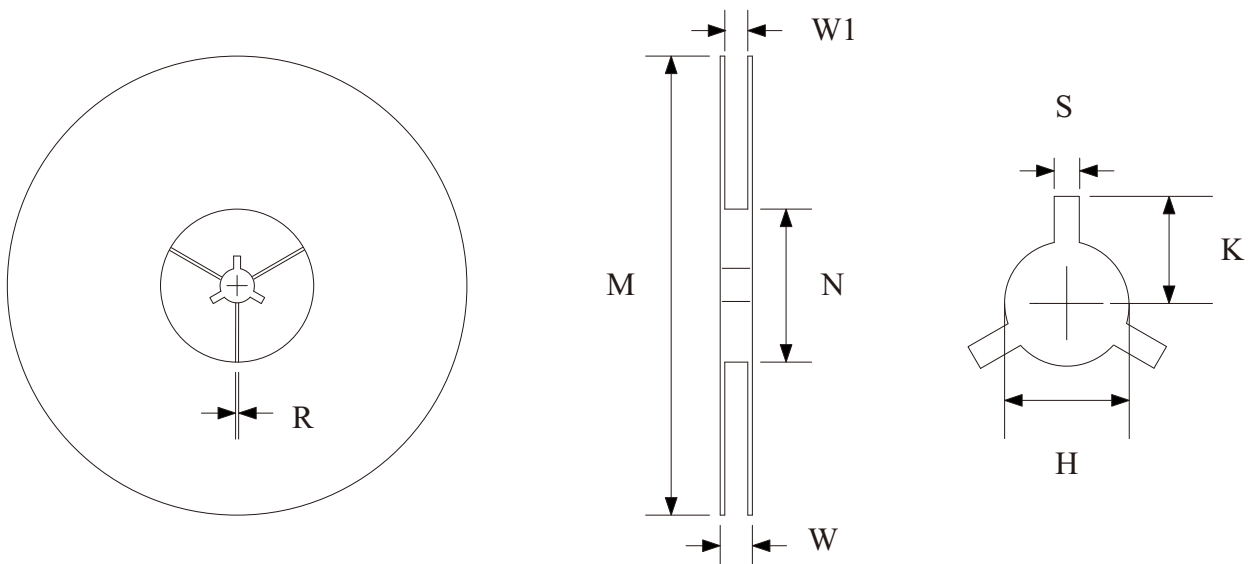

Symbol	Reel Size	M	N	W	W1	H	S	K	R
Dimensions (mm)	$\Phi 178$	178.0±1.0	60.0±1.0	11.5±0.5	9.0±0.5	13.0±0.5	2.0±0.1	11.0±0.2	1.0±0.05

## Marking Codes

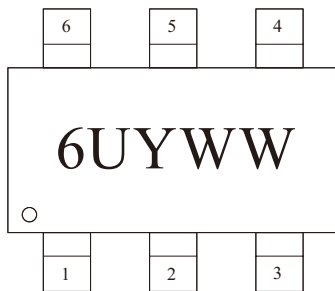

## Ordering Information

Part Number	Working Voltage	Quantity Per Reel	Reel Size
T0514TL	5V	3,000	7 Inch

**Note:**

- (1) "6U" is part number, fixed.
- (2) "YWW" is date code. "Y" is the assembly year (2011 is "1"); while "WW" is the assembly week in a year.

## Footprint: SOT23-6L

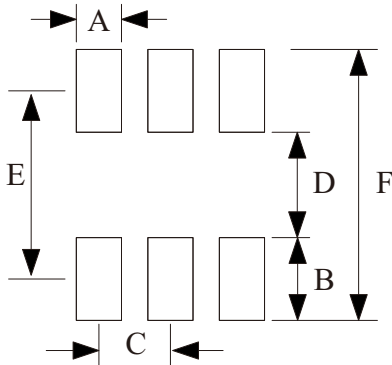

Symbol	Dimensions	
	Millimeters	Inches
A	0.60	0.024
B	1.10	0.043
C	0.95	0.037
D	1.40	0.055
E	2.50	0.098
F	3.60	0.141



- CITC reserves the right to make changes to this document and its products and specifications at any time without notice.
- Customers should obtain and confirm the latest product information and specifications before final design, purchase or use.
- CITC makes no warranty, representation or guarantee regarding the suitability of its products for any particular purpose, nor does CITC assume any liability for application assistance or customer product design.
- CITC does not warrant or accept any liability with products which are purchased or used for any unintended or unauthorized application.
- No license is granted by implication or otherwise under any intellectual property rights of CITC.
- CITC products are not authorized for use as critical components in life support devices or systems without express written approval of CITC.