

Features

- Transient protection for high-speed data lines
 - IEC 61000-4-2 (ESD) $\pm 27\text{kV}$ (Air)
 - $\pm 17\text{kV}$ (Contact)
 - IEC 61000-4-4 (EFT) 40A (5/50 ns)
 - Cable Discharge Event (CDE)
- Small package (2.9mm x 2.8mm x 1.4mm)
- Protects four data lines
- Low capacitance: 0.7pF Typical (I/O-GND)
- Low leakage current: 0.1 μA @ V_{RWM} (Typical)
- Low clamping voltage
- Each I/O pin can withstand over 1000 ESD strikes for $\pm 8\text{kV}$ contact discharge
- Green part

Description

T0514VL is an ultra-low capacitance Transient Voltage Suppressor (TVS) designed to provide electrostatic discharge (ESD) protection for high-speed data interfaces. With typical capacitance of 0.7pF only, T0514VL is designed to protect parasitic-sensitive system against over-voltage and over-current transient events. It complies with IEC61000-4-2(ESD) ,Level 4 ($\pm 15\text{kV}$ air, $\pm 8\text{kV}$ contact discharge),IEC 61000-4-4 (electrical fast transient - EFT) (40A,5/50ns) , very fast charged device model (CDM)ESD and cable discharge event (CBE),etc.

T0514VL user SOT23-6L package. Each T0514VL device can protect four high-speed data lines. The combined features of low capacitance, small size and high ESD robustness make T0514VL ideal for high-speed data ports and high-frequency lines (e.g., HDMI & DVI) applications. The low clamping voltage of the T0514VL guarantees a minimum stress on the protected IC.

Applications

- Video Graphics Cards
- Desktops, Servers and Notebooks
- IEEE 1394 Ports
- USB 2.0/3.0 Power and Data Line Protection
- Display Ports
- SIM Ports

Mechanical Characteristics

- SOT23-6L package
- Flammability Rating: UL 94V-0
- Marking: Part number
- Packaging: Tape and Reel

Circuit Diagram

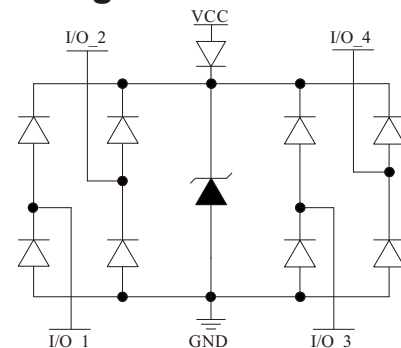

Pin Configuration

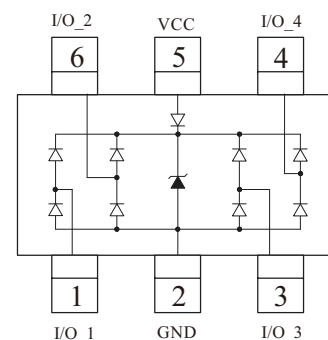

SOT23-6L
(Top View)

Absolute Maximum Rating

Symbol	Parameter	Value	Units
V_{ESD}	ESD per IEC 61000-4-2 (Air)	±27	kV
	ESD per IEC 61000-4-2 (Contact)	±17	
T_{OPT}	Operating Temperature	-55/+125	°C
T_{STG}	Storage Temperature	-55/+150	°C

Electrical Characteristics (T = 25 °C)

Symbol	Parameter
V_{RWM}	Nominal Reverse Working Voltage
I_R	Reverse Leakage Current @ V_{RWM}
V_{BR}	Reverse Breakdown Voltage @ I_T
I_T	Test Current for Reverse Breakdown
V_C	Clamping Voltage @ I_{PP}
I_{PP}	Maximum Peak Pulse Current
C_{ESD}	Parasitic Capacitance
V_R	Reverse Voltage
f	Small Signal Frequency
I_F	Forward Current
V_F	Forward Voltage @ I_F

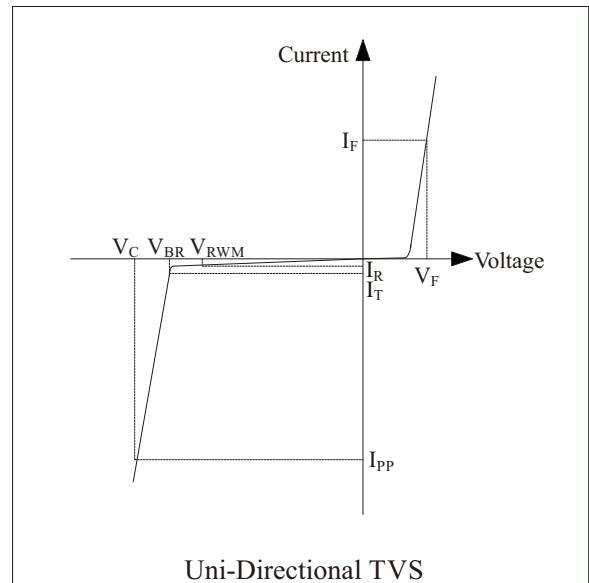

Symbol	Test Condition	Minimum	Typical	Maximum	Units
V_{RWM}				5.0	V
I_R	$V_{RWM} = 5V, T = 25^\circ C$ Between I/O and GND		0.1	1.0	μA
V_{BR}	$I_T = 1mA$ Between I/O and GND	6.0	8.0	10.0	V
V_C	$I_{PP} = 1A, t_p = 8/20\mu s$ Between I/O and GND			12.0	V
C_{ESD}	$V_R = 0V, f = 1MHz$ Between I/O and GND		0.7	0.8	pF
C_{ESD}	$V_R = 0V, f = 1MHz$ Between I/O and I/O		0.35		pF

Voltage Sweeping of I/O to GND

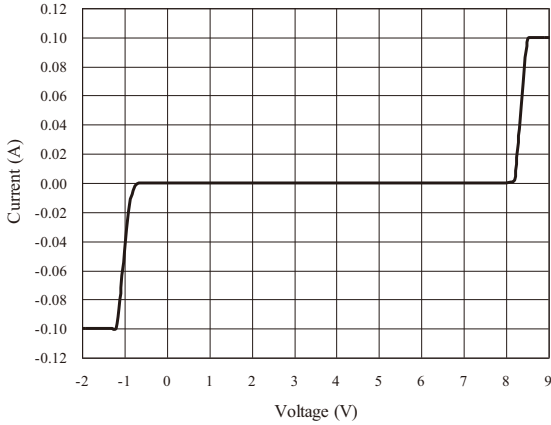

Insertion Loss S21 of I/O to GND

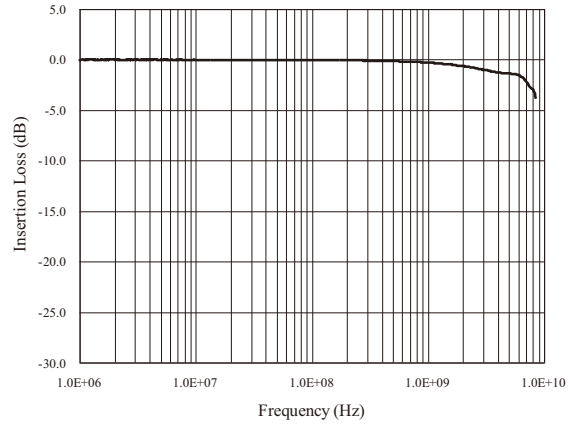

Capacitance vs. Voltage of I/O to GND (f = 1MHz)

Capacitance vs. Reverse Voltage

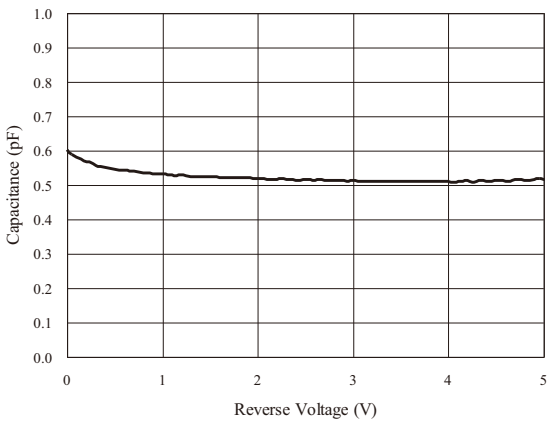

Normalized Capacitance vs. Reverse Voltage

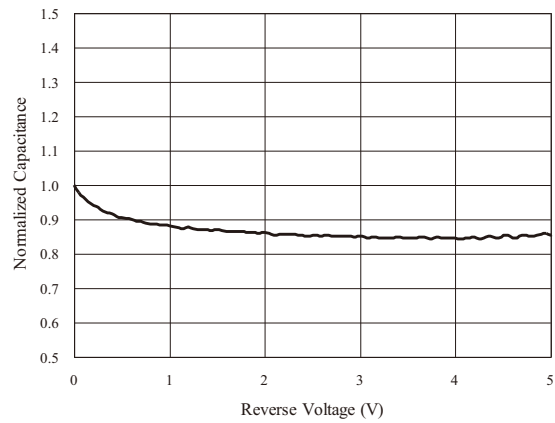

ESD Clamping of I/O to GND (+8kV Contact per IEC 61000-4-2)

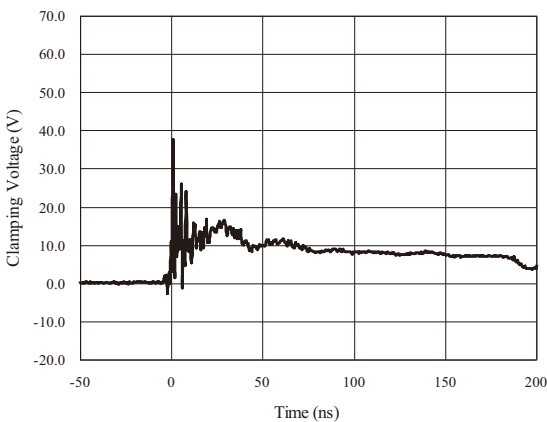

ESD Clamping of I/O to GND (-8kV Contact per IEC 61000-4-2)

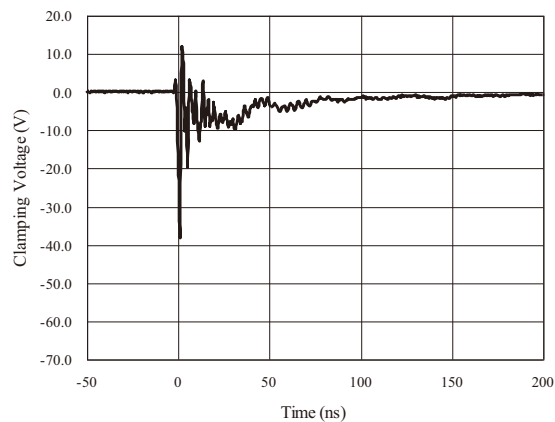

Application Information

Pin Connection in PCB

T0514VL is capable to provide ESD protection for four data lines simultaneously. The pin connection is shown in Figure 1.

Four parallel data lines, from inner IC to I/O port connector, could connect to T0514VL four I/O pins directly. Pin 2 of T0514VL is the negative reference pin, which should connect to the GND of PCB. The connection wires should be as short as possible in order to minimize the parasitic inductance.

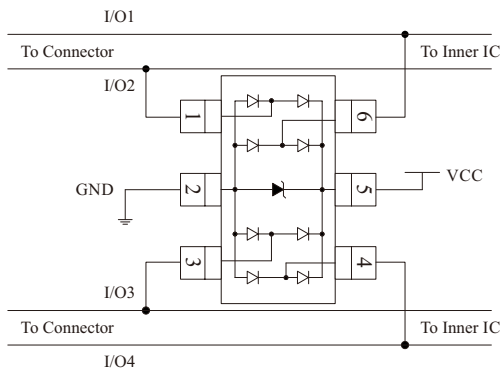

Figure 1 T0514VL pin connection in PCB

PCB Layout Guidelines

For optimum ESD protection and the whole circuit performance, the following PCB layout guidelines are recommended:

- T0514VL GND pin to the PCB GND rail path should be as short as possible. It could reduce the ESD transient return path to GND.
- The vias connecting T0514VL VCC & GND pins to the PCB VCC & GND should be wide.
- Place T0514VL as close to the connector port as possible. It could reduce the parasitic inductance and restrict ESD coupling into adjacent traces.
- Avoid running critical signals near board edges.

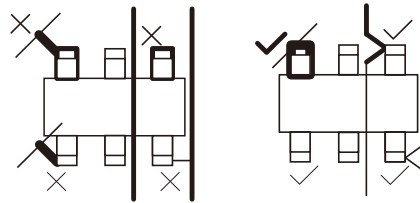
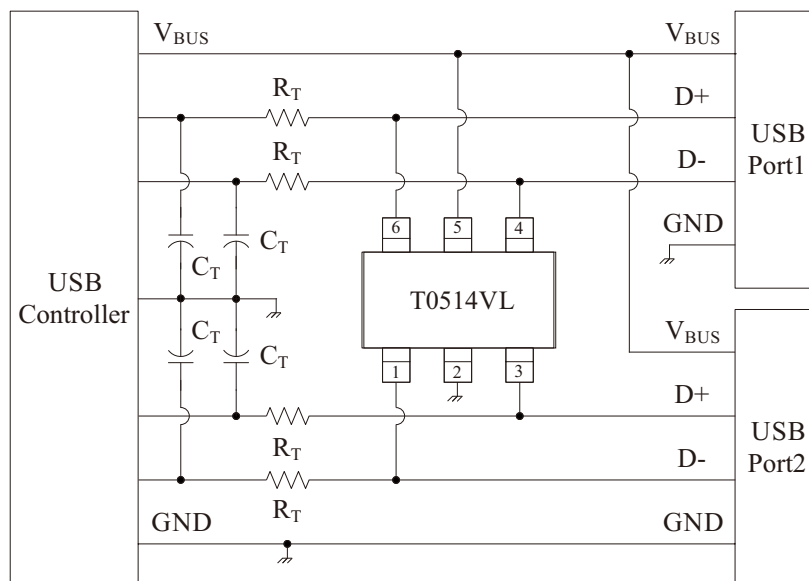
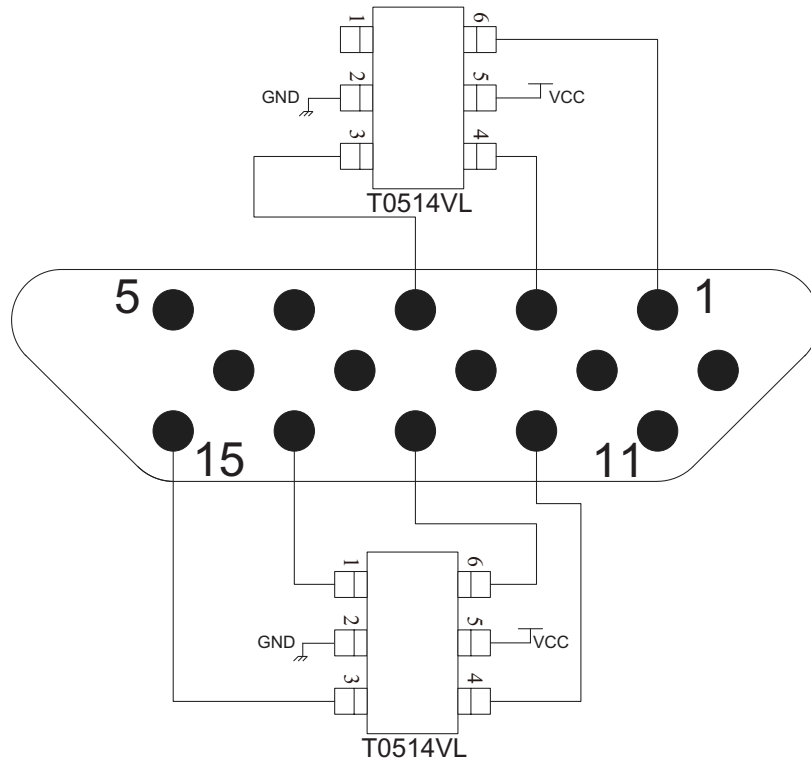

Figure 2 T0514VL Layout Guideline

Universal Serial Bus ESD Protection



Application Information (continued)



Layout Top View for Video (VGA) Interface with T0514VL

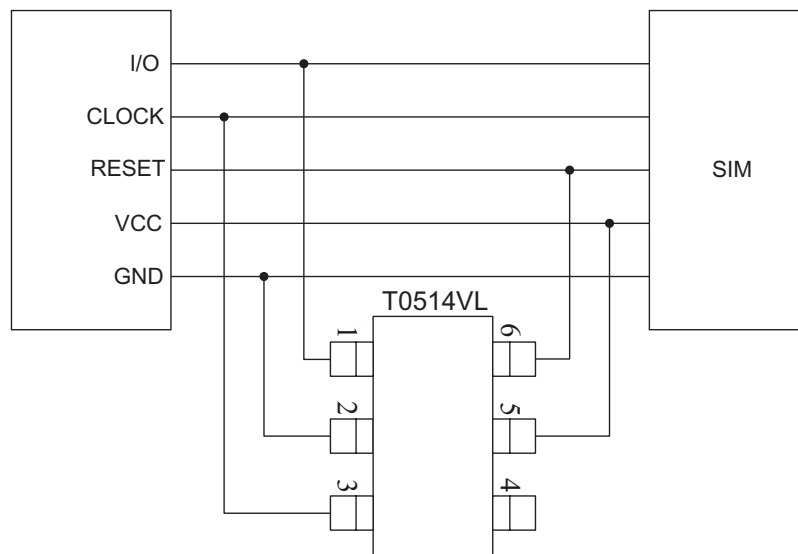

Layout Top View for SIM Port with T0514VL

Package Outline

SOT23-6L package

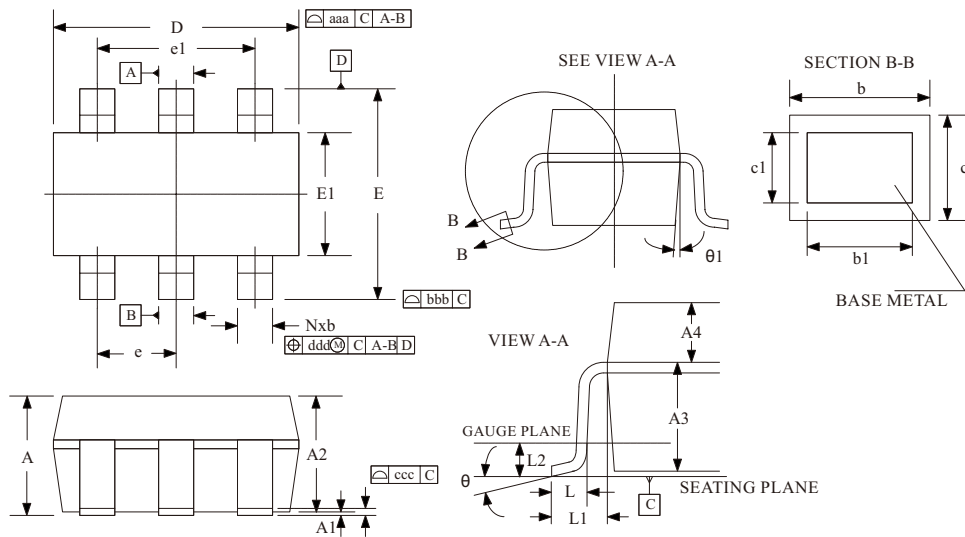

Package Dimensions (Controlling dimensions are in millimeters)

Symbol	Dimensions (mm)			Dimensions (Inches)		
	Minimum	Typical	Maximum	Minimum	Typical	Maximum
A	---	---	1.450	---	---	0.057
A1	0.000	---	0.150	0.000	---	0.006
A2	0.900	1.200	1.300	0.035	0.047	0.012
A3	0.637	0.787	0.837	0.025	0.031	0.033
A4	0.263	0.413	0.463	0.010	0.016	0.018
b	0.300	---	0.500	0.012	---	0.020
b1	0.300	0.400	0.450	0.012	0.016	0.018
c	0.080	---	0.220	0.003	---	0.009
c1	0.080	0.130	0.200	0.003	0.005	0.008
D	2.90 BSC			0.114 BSC		
e	0.95 BSC			0.037 BSC		
e1	1.90 BSC			0.075 BSC		
E	2.80 BSC			0.110 BSC		
E1	1.60 BSC			0.063 BSC		
L	0.300	0.450	0.600	0.012	0.018	0.024
L1	0.600 REF			0.024 REF		
L2	0.250 BSC			0.010 BSC		
theta	0°	4°	8°	0°	4°	8°
theta1	5°	10°	15°	5°	10°	15°
aaa	0.150			0.006		
bbb	0.200			0.008		
ccc	0.100			0.004		
ddd	0.100			0.004		

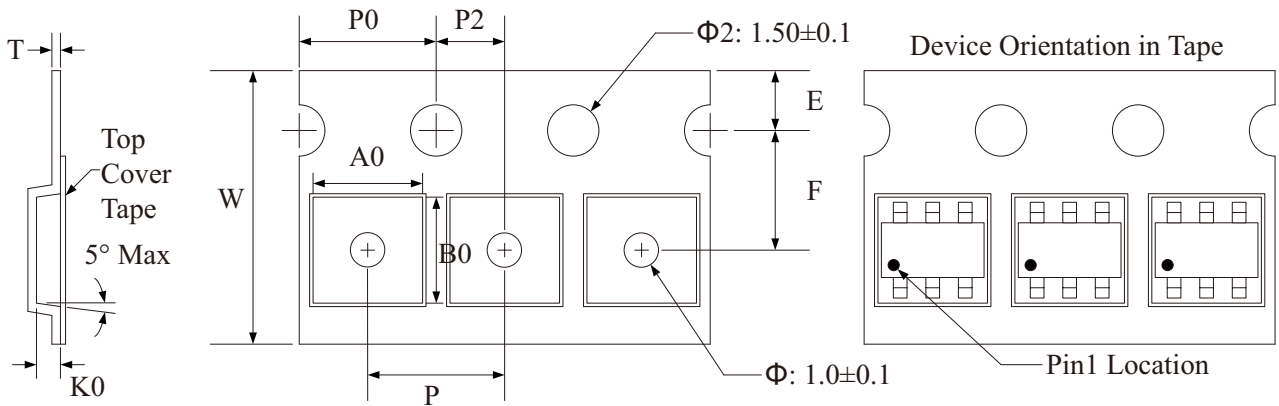
Tape and Reel Specification

Symbol	W	A0	B0	K0	E	F	P	P0	P2	T
Dimensions (mm)	8.00+0.3 -0.1	3.23±0.05	3.17±0.05	1.37±0.05	1.75±0.1	3.5±0.05	4.0±0.1	4.0±0.1	2.0±0.05	0.25±0.02

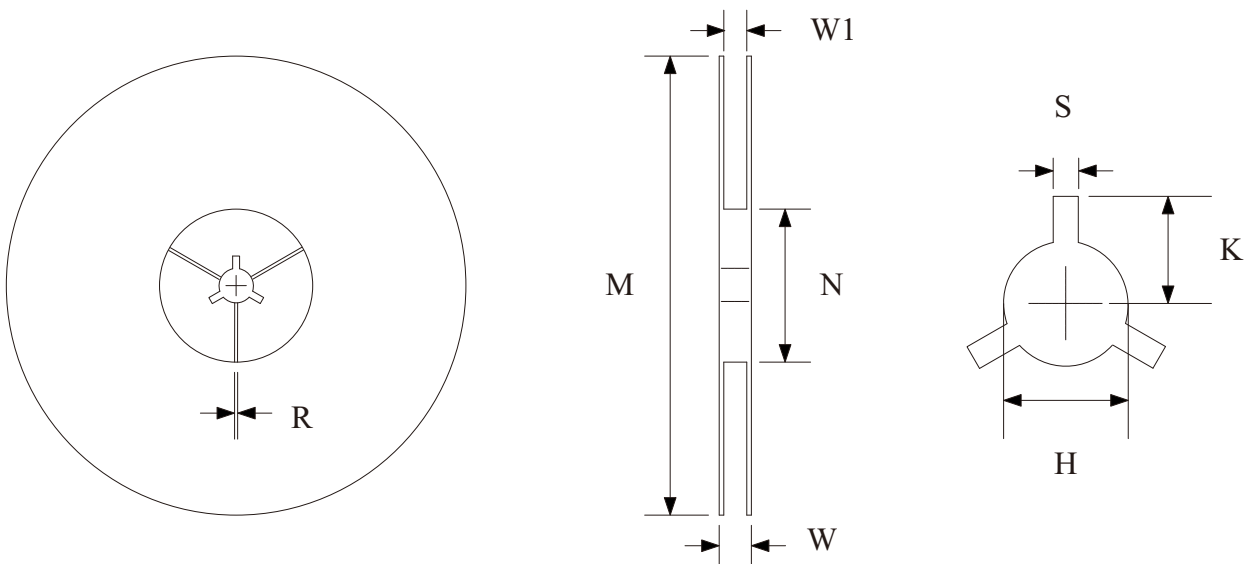

Symbol	Reel Size	M	N	W	W1	H	S	K	R
Dimensions (mm)	$\Phi 178$	178.0±1.0	60.0±1.0	11.5±0.5	9.0±0.5	13.0±0.5	2.0±0.1	11.0±0.2	1.0±0.05

Marking Codes

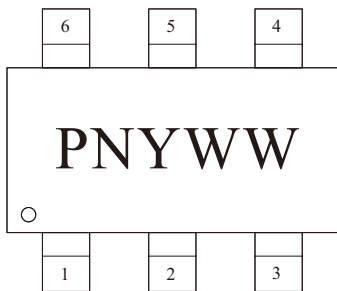

Or

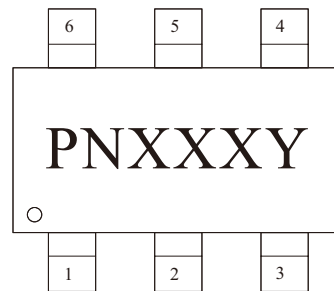

Note:

- (1) PN is "16" or "6U", and is part number, fixed.
- (2) "YWW" is date code. "Y" is the assembly year (2012 is "2"); while "WW" is the assembly week in a year.

Note:

- (1) PN is "16" or "6U", and is part number, fixed.
- (2) "XXX" is the last 3 characters of the wafer's Lot No., "Y" is the internal code.

Ordering Information

Part Number	Working Voltage	Quantity Per Reel	Reel Size
T0514VL	5V	3,000	7 Inch

Footprint: SOT23-6L

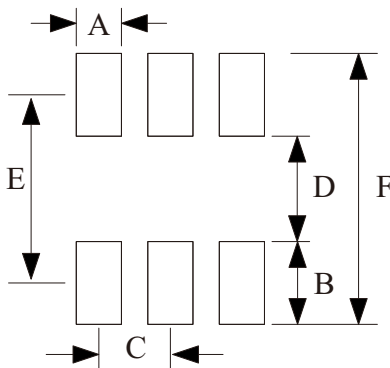

Symbol	Dimensions	
	Millimeters	Inches
A	0.60	0.024
B	1.10	0.043
C	0.95	0.037
D	1.40	0.055
E	2.50	0.098
F	3.60	0.141

- CITC reserves the right to make changes to this document and its products and specifications at any time without notice.
- Customers should obtain and confirm the latest product information and specifications before final design, purchase or use.
- CITC makes no warranty, representation or guarantee regarding the suitability of its products for any particular purpose, nor does CITC assume any liability for application assistance or customer product design.
- CITC does not warrant or accept any liability with products which are purchased or used for any unintended or unauthorized application.
- No license is granted by implication or otherwise under any intellectual property rights of CITC.
- CITC products are not authorized for use as critical components in life support devices or systems without express written approval of CITC.