



### DESCRIPTION:

T06xxH series triacs of high junction temperature with high dv/dt rate with strong resistance to electromagnetic interference provide high ability to withstand the shock loading of large current. They are especially recommended for use on inductive load and high environment temperature condition.

T06xxH-xxA provides insulation voltage rated at 2500V RMS and T06xxH-xxF provides insulation voltage rated at 2000V RMS from all three terminals to external heatsink complying with UL standards (File ref: E252906).

### MAIN FEATURES

Symbol	Value	Unit
$I_{T(RMS)}$	6	A
$V_{DRM}/V_{RRM}$	600 and 800	V
$T_{jmax}$	150	°C

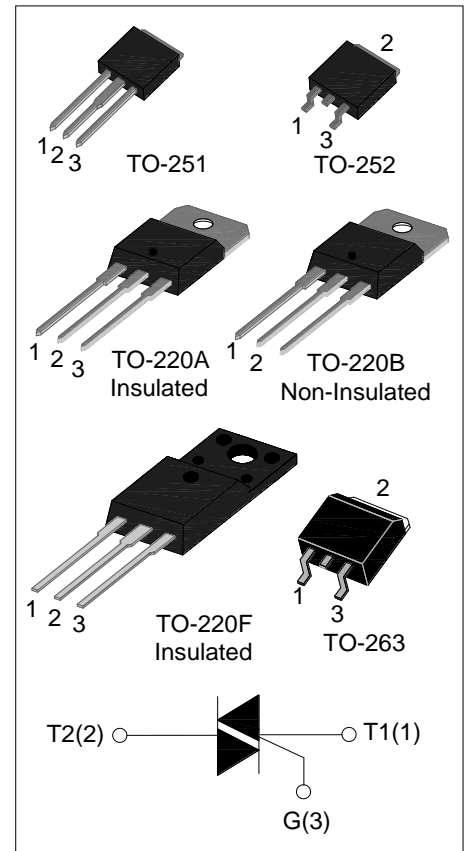

### ABSOLUTE MAXIMUM RATINGS

Parameter		Symbol	Value	Unit
Storage junction temperature range		$T_{stg}$	-40-150	°C
Operating junction temperature range		$T_j$	-40-150	°C
Repetitive peak off-state voltage( $T_j=25^\circ\text{C}$ )		$V_{DRM}$	600/800	V
Repetitive peak reverse voltage( $T_j=25^\circ\text{C}$ )		$V_{RRM}$	600/800	V
Non repetitive surge peak Off-state voltage		$V_{DSM}$	$V_{DRM} + 100$	V
Non repetitive peak reverse voltage		$V_{RSM}$	$V_{RRM} + 100$	V
RMS on-state current	TO-251/ TO-252( $T_C=86^\circ\text{C}$ )	$I_{T(RMS)}$	6	A
	TO-220A(Ins)/ TO-220F(Ins) ( $T_C=96^\circ\text{C}$ )			
	TO-220B(Non-Ins)( $T_C=107^\circ\text{C}$ )			
	TO-263 ( $T_C=113^\circ\text{C}$ )			

Non repetitive surge peak on-state current (full cycle, F=50Hz)	$I_{TSM}$	60	A
$I^2t$ value for fusing (tp=10ms)	$I^2t$	21	$A^2s$
Critical rate of rise of on-state current ( $I_G=2 \times I_{GT}$ )	dI/dt	50	$A/\mu s$
Peak gate current	$I_{GM}$	2	A
Average gate power dissipation	$P_{G(AV)}$	1	W
Peak gate power	$P_{GM}$	5	W

**ELECTRICAL CHARACTERISTICS** ( $T_j=25^\circ C$  unless otherwise specified)

Symbol	Test Condition	Quadrant		Value				Unit
				T0610H	T0620H	T0635H	T0650H	
$I_{GT}$	$V_D=12V R_L=33\Omega$	I - II - III	MAX	10	20	35	50	mA
$V_{GT}$		I - II - III	MAX	1.5				V
$V_{GD}$	$V_D=V_{DRM} T_j=150^\circ C$ $R_L=3.3K\Omega$	I - II - III	MIN	0.2				V
$I_L$	$I_G=1.2I_{GT}$	I - III	MAX	15	40	50	70	mA
		II		25	55	70	100	
$I_H$	$I_T=100mA$		MAX	15	30	45	60	mA
dV/dt	$V_D=2/3V_{DRM} R_{GK}=1K\Omega T_j=150^\circ C$		MIN	200	500	1000	1500	$V/\mu s$
(dV/dt) <sub>c</sub>	$V_D=400V T_j=150^\circ C$ (dI/dt) <sub>c</sub> =-2.6A/ms		MIN	2	5	15	20	$V/\mu s$

**STATIC CHARACTERISTICS**

Symbol	Parameter		Value(MAX)	Unit
$V_{TM}$	$I_{TM}=8.5A tp=380\mu s$	$T_j=25^\circ C$	1.55	V
$I_{DRM}$	$V_D=V_{DRM} V_R=V_{RRM}$	$T_j=25^\circ C$	5	$\mu A$
$I_{RRM}$		$T_j=150^\circ C$	1.5	mA

**THERMAL RESISTANCES**

Symbol	Parameter	Value	Unit
$R_{th(j-c)}$	junction to case(AC)	TO-251/TO-252	4.2
		TO-220A(Ins)/ TO-220F(Ins)	3.9
		TO-220B(Non-Ins)	2.7
		TO-263	2.1

**ORDERING INFORMATION**

<p><b>T</b></p> <p>Triacs</p> <p><math>I_{T(RMS)}:6A</math></p> <p>10: <math>I_{GT1-3} \leq 10mA</math></p> <p>20: <math>I_{GT1-3} \leq 20mA</math></p> <p>35: <math>I_{GT1-3} \leq 35mA</math></p> <p>50: <math>I_{GT1-3} \leq 50mA</math></p>	<p><b>06</b></p>	<p><b>20</b></p>	<p><b>H</b></p>	<p><b>-6</b></p> <p>6: <math>V_{DRM} / V_{RRM} \geq 600V</math></p> <p>8: <math>V_{DRM} / V_{RRM} \geq 800V</math></p> <p>High junction temperature</p>	<p><b>F</b></p> <p>E: TO-263</p> <p>A: TO-220A(Ins)</p> <p>F: TO-220F(Ins)</p> <p>B: TO-220B(Non-Ins)</p> <p>H: TO-251 K: TO-252</p>
---	------------------	------------------	-----------------	---	--

**PACKAGE MECHANICAL DATA**

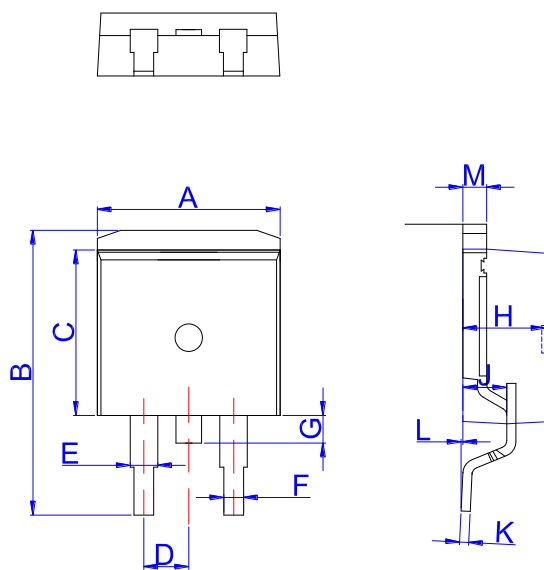

TO-263

Ref.	Dimensions					
	Millimeters			Inches		
	Min.	Typ.	Max.	Min.	Typ.	Max.
A	9.90		10.20	0.390		0.402
B	14.70		15.80	0.579		0.622
C	9.4		9.6	0.37		0.378
D		2.54			0.100	
E	1.20		1.40	0.047		0.055
F	0.75		0.85	0.029		0.033
G			1.75			0.069
H	4.40		4.70	0.173		0.185
J	2.30		2.70	0.091		0.106
K	0.38		0.55	0.015		0.022
L	0	0.10	0.25	0	0.004	0.010
M	1.25		1.35	0.049		0.053

PACKAGE MECHANICAL DATA

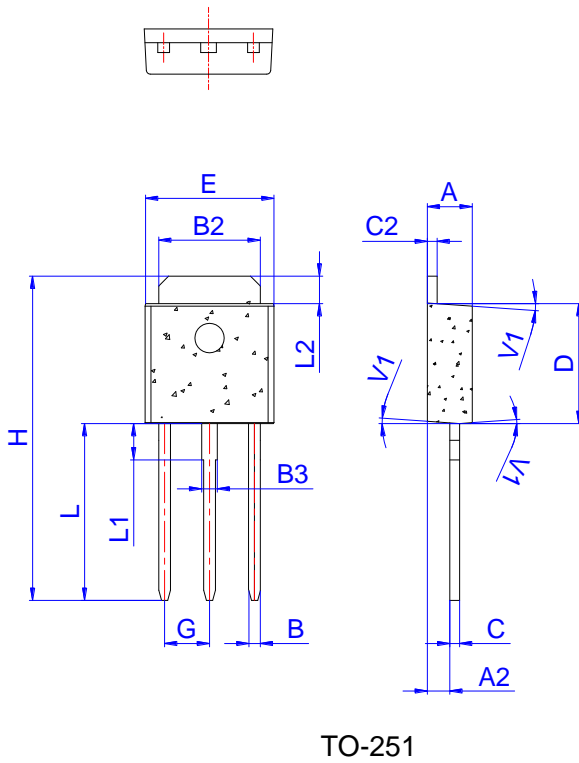

Ref.	Dimensions					
	Millimeters			Inches		
	Min.	Typ.	Max.	Min.	Typ.	Max.
A	2.20		2.40	0.086		0.095
A2	0.90		1.20	0.035		0.047
B	0.55		0.65	0.022		0.026
B2	5.10		5.40	0.200		0.213
B3	0.76		0.85	0.030		0.033
C	0.45		0.62	0.018		0.024
C2	0.48		0.62	0.019		0.024
D	6.00		6.20	0.236		0.244
E	6.40		6.70	0.252		0.264
G		2.30			0.091	
H	16.0		17.0	0.630		0.669
L	8.90		9.40	0.350		0.370
L1	1.80		1.90	0.071		0.075
L2	1.37		1.50	0.054		0.059
V1		4°			4°	

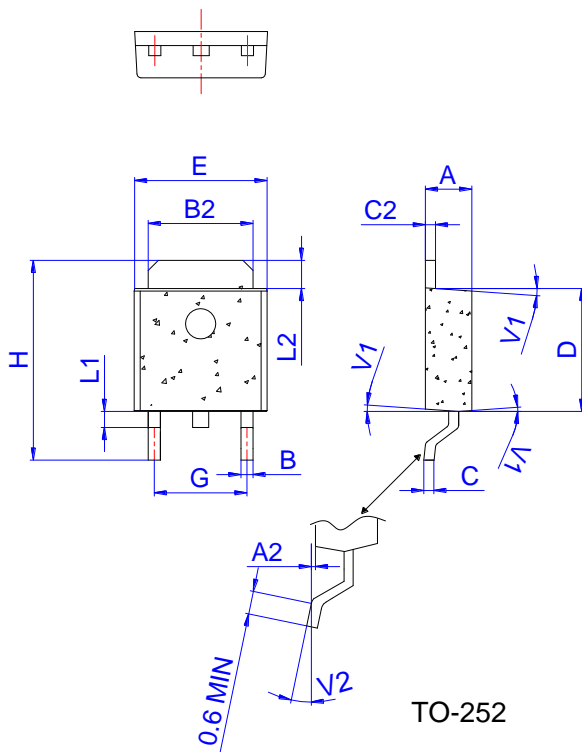

Ref.	Dimensions					
	Millimeters			Inches		
	Min.	Typ.	Max.	Min.	Typ.	Max.
A	2.20		2.40	0.086		0.095
A2	0.03		0.23	0.001		0.009
B	0.55		0.65	0.022		0.026
B2	5.10		5.40	0.200		0.213
C	0.45		0.62	0.018		0.024
C2	0.48		0.62	0.019		0.024
D	6.00		6.20	0.236		0.244
E	6.40		6.70	0.252		0.264
G	4.40		4.70	0.173		0.185
H	9.35		10.6	0.368		0.417
L1	1.30		1.70	0.051		0.067
L2	1.37		1.50	0.054		0.059
V1		4°			4°	
V2	0°		8°	0°		8°

PACKAGE MECHANICAL DATA

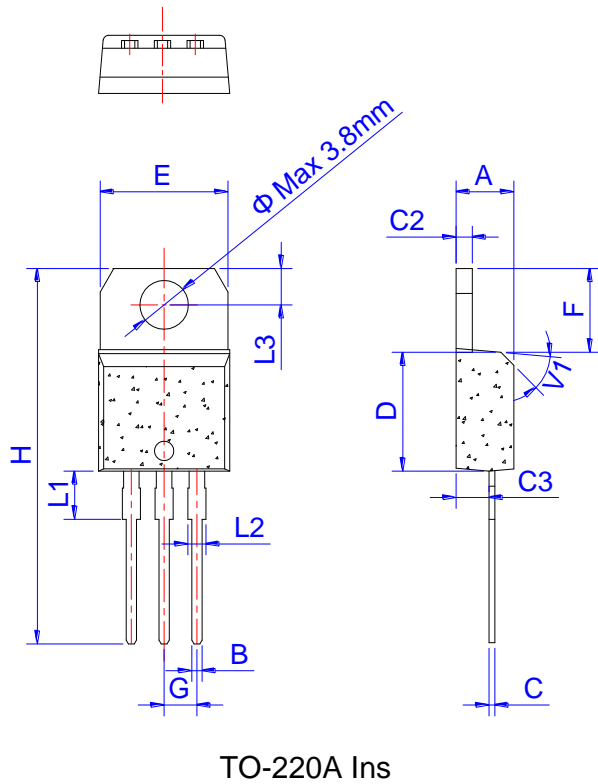

Ref.	Dimensions					
	Millimeters			Inches		
	Min.	Typ.	Max.	Min.	Typ.	Max.
A	4.40		4.60	0.173		0.181
B	0.61		0.88	0.024		0.035
C	0.46		0.70	0.018		0.028
C2	1.21		1.32	0.048		0.052
C3	2.40		2.72	0.094		0.107
D	8.60		9.70	0.339		0.382
E	9.80		10.4	0.386		0.409
F	6.55		6.95	0.258		0.274
G		2.54			0.1	
H	28.0		29.8	1.102		1.173
L1		3.75			0.148	
L2	1.14		1.70	0.045		0.067
L3	2.65		2.95	0.104		0.116
V1		45°			45°	

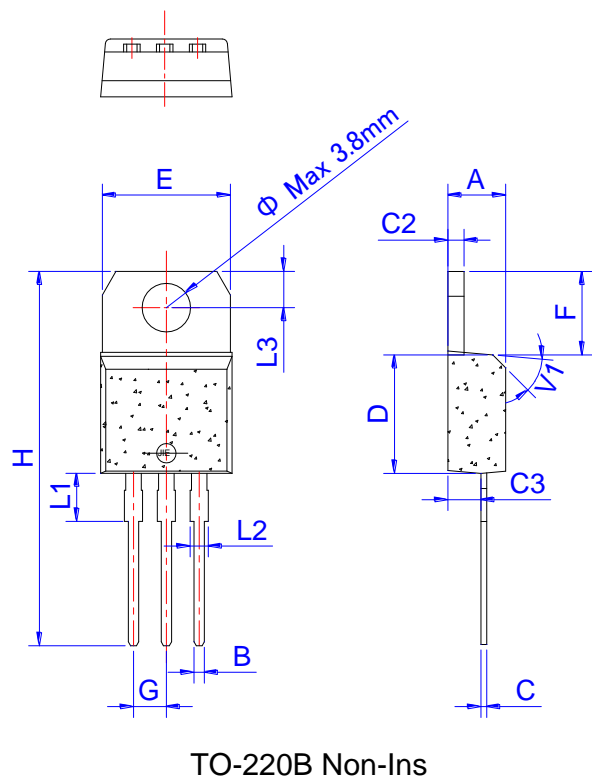

Ref.	Dimensions					
	Millimeters			Inches		
	Min.	Typ.	Max.	Min.	Typ.	Max.
A	4.40		4.60	0.173		0.181
B	0.61		0.88	0.024		0.035
C	0.46		0.70	0.018		0.028
C2	1.21		1.32	0.048		0.052
C3	2.40		2.72	0.094		0.107
D	8.60		9.70	0.339		0.382
E	9.60		10.4	0.378		0.409
F	6.20		6.60	0.244		0.260
G		2.54			0.1	
H	28.0		29.8	1.102		1.173
L1		3.75			0.148	
L2	1.14		1.70	0.045		0.067
L3	2.65		2.95	0.104		0.116
V1		45°			45°	

PACKAGE MECHANICAL DATA

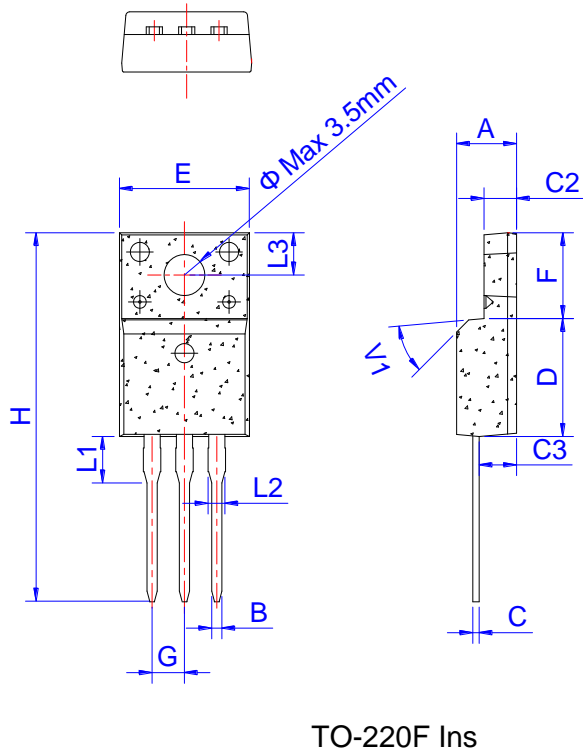

Ref.	Dimensions					
	Millimeters			Inches		
	Min.	Typ.	Max.	Min.	Typ.	Max.
A	4.40		4.80	0.173		0.189
B	0.74	0.80	0.83	0.029	0.031	0.033
C	0.48		0.75	0.019		0.030
C2	2.40		2.70	0.094		0.106
C3	2.60		3.00	0.102		0.118
D	8.80		9.30	0.346		0.366
E	9.70		10.3	0.382		0.406
F	6.40		7.00	0.252		0.276
G		2.54			0.1	
H	28.0		29.8	1.102		1.173
L1		3.63			0.143	
L2	1.14		1.70	0.045		0.067
L3		3.30			0.130	
V1		45°			45°	

FIG.1 Maximum power dissipation versus RMS on-state current

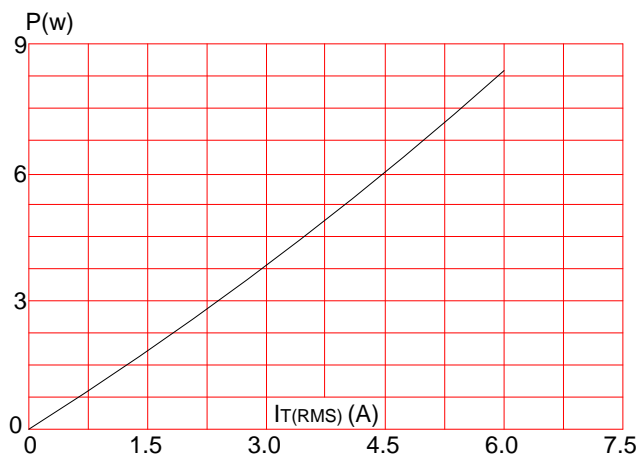
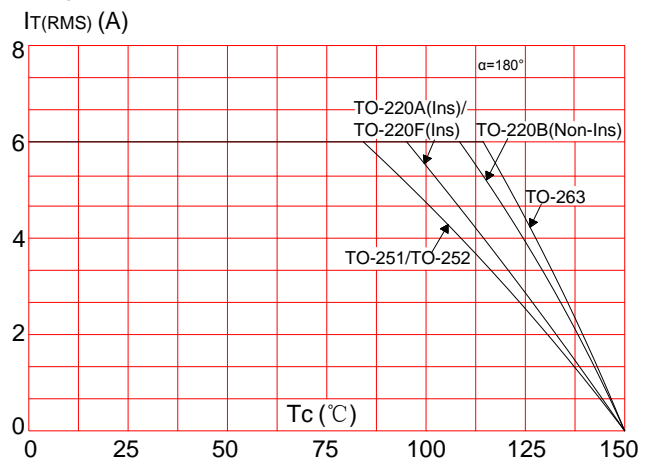
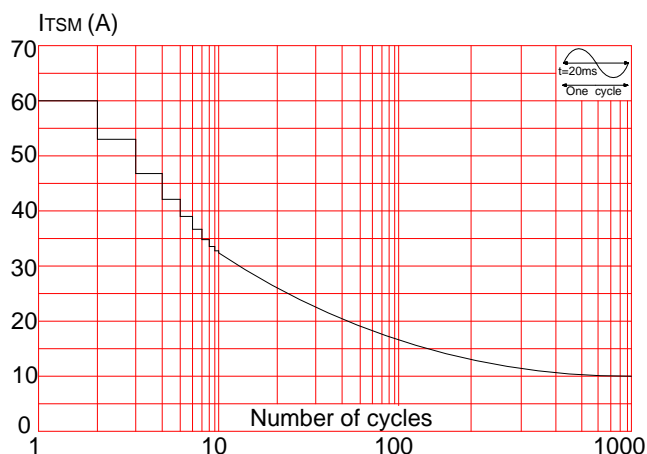

FIG.2: RMS on-state current versus case temperature



**FIG.3:** Surge peak on-state current versus number of cycles



**FIG.5:** Non-repetitive surge peak on-state current for a sinusoidal pulse with width  $t_p < 20\text{ms}$ , and corresponding value of  $I^2t$  ( $di/dt < 50\text{A}/\mu\text{s}$ )

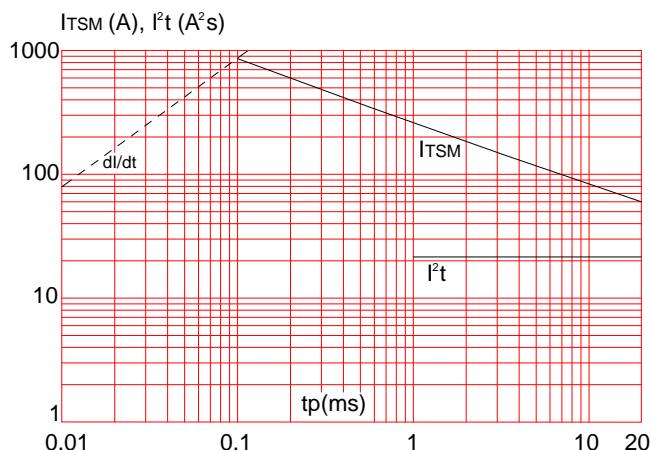

**FIG.4:** On-state characteristics (maximum values)

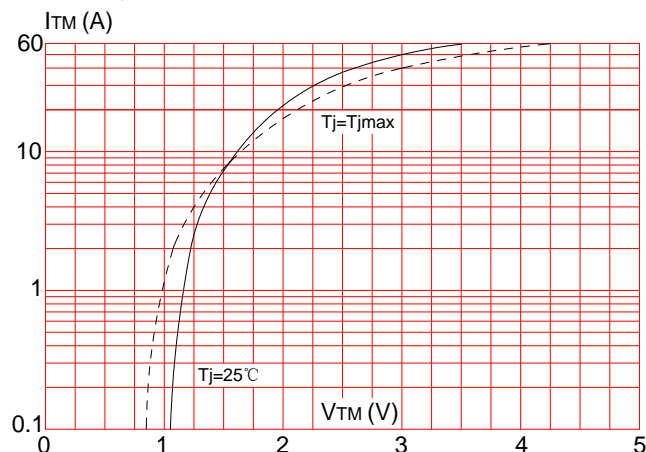

**FIG.6:** Relative variations of gate trigger current, holding current and latching current versus junction temperature

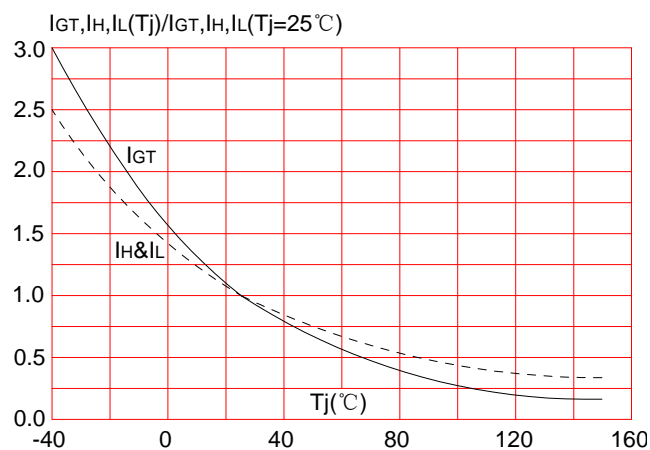

Information furnished in this document is believed to be accurate and reliable. However, Jiangsu JieJie Microelectronics Co.,Ltd assumes no responsibility for the consequences of use without consideration for such information nor use beyond it.

Information mentioned in this document is subject to change without notice, apart from that when an agreement is signed, Jiangsu JieJie complies with the agreement.

Products and information provided in this document have no infringement of patents. Jiangsu JieJie assumes no responsibility for any infringement of other rights of third parties which may result from the use of such products and information.

This document is the third version which is made in 10-June-2015. This document supersedes and replaces all information previously supplied.

 is a registered trademark of Jiangsu JieJie Microelectronics Co.,Ltd.

Copyright ©2015 Jiangsu JieJie Microelectronics Co.,Ltd. Printed All rights reserved.