

## T08 8A TRIACs

### FEATURES

- Glass Passivated Junctions
- High voltage and surge capability
- Low Thermal Resistance and Durability
- Triggering in three quadrants

### APPLICATIONS

- Static relays
- Heating regulation
- In-duction motor starting circuits
- Phase control operation in light dimmers
- Motor speed controllers



### Parameters Summary

VD/VR:600/800V IT(RMS):8A IGT :05 to 50mA

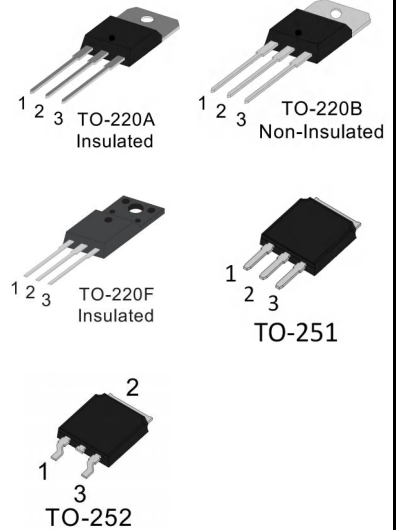
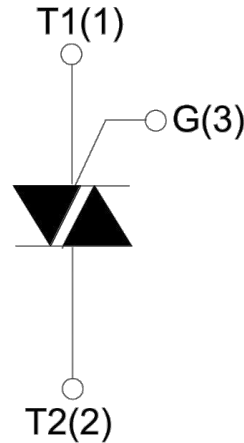

ABSOLUTE MAXIMUM RATINGS			
Parameter	Symbol	Value	Unit
Storage junctiontemperature range	Tstg	-40~150	°C
Operating junction temperature range	Tj	-40~150	°C
Repetitive peak off-state voltage (T =25°C)	V <sub>DRM</sub>	600/800	V
Repetitive peak reverse voltage (T =25°C)	V <sub>RRM</sub>	600/800	V
RMS on-state current	TO-220A(TC=100°C)	8	A
	TO-220B/TO-251/ TO-252(TC=107°C)		
	TO-220F(TC=95°C)		
Non repetitive surge peak on-state current (full cycle, F=50Hz)	I <sub>TSM</sub>	80	A
I <sup>2</sup> t value for fusing (tp=10ms)	I <sup>2</sup> t	32	A <sup>2</sup> S
Critical rate of rise of on-state current(I =2×I <sub>GT</sub> )	di/dt	50	A/μS
Peak gate current	I <sub>GM</sub>	4	A
Peakgate power dissipation	P <sub>GM</sub>	5	W
Average gate power dissipation	P <sub>G(AV)</sub>	1	W

Thermal Resistances			
Symbol	Parameter	Value	Unit
Rth(j-c)	Junction to case (DC)	TO-220A	2.7
		TO-220B	1.8
		TO-220F	2.9
		TO-251/TO-252	2.1

ELECTRICAL CHARACTERISTICS (T=25°C unless otherwise specified)								
Symbol	Test Condition	Quadrant		Value				Unit
				5	10	35	50	
$I_{GT}$	$V_D=12V, I_T=0.1A, T_j=25^\circ C$	I II III	MAX.	5	10	35	50	mA
$V_{GT}$	$^\circ C$	I II III	MAX.	1.5				V
$V_{GD}$	$V_D=V_{DRM}, T_j=125^\circ C$	I II III	MIN.	0.2				V
$I_L$	$I_G=1.2I_{GT}$	I-III	MAX.	20	25	50	70	mA
		II		25	35	90	100	
$I_H$	$I_T=100mA$		MAX.	15	20	40	60	mA
dV/dt	$V_D=2/3V_{DRM}$ Gate Open $T_j=125^\circ C$		MIN.	50	200	500	1000	V/ $\mu s$

STATIC CHARACTERISTICS				
Symbol	Parameter		Value(MAX. )	Unit
$V_{TM}$	$I_{TM}=11A$ tp=380 $\mu s$	$T_j=25^\circ C$	1.55	V
$I_{DRM}$	$V_D=V_{DRM}, V_R=V_{RRM}$	$T_j=25^\circ C$	5	$\mu A$
$I_{RRM}$		$T_j=125^\circ C$	1	mA

### Ordering Information Scheme

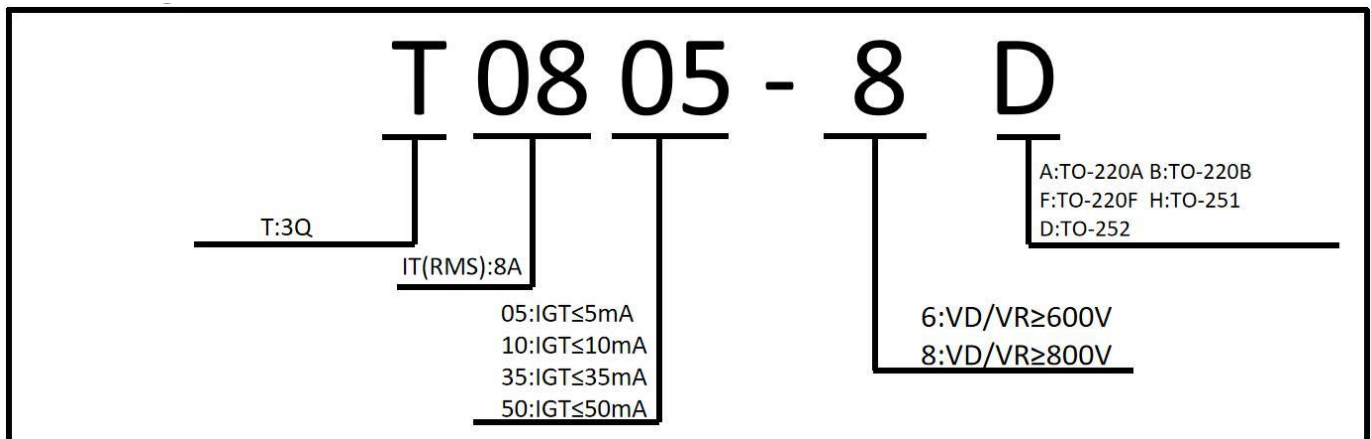

### TO-220A Package Mechanical Data

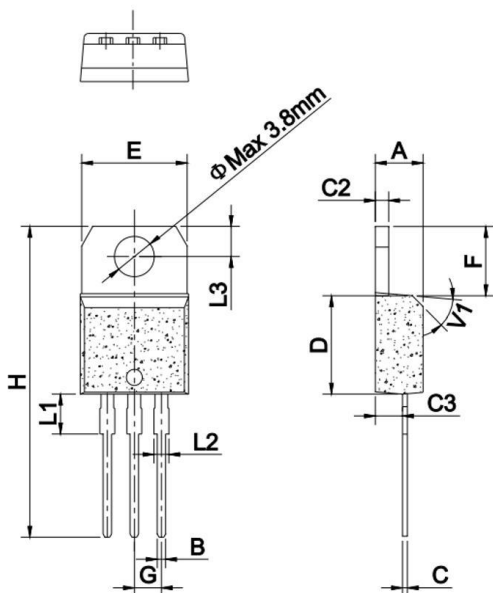

Ref.	Dimensions					
	Millimeters			Inches		
	Min.	Typ.	Max.	Min.	Typ.	Max.
A	4.40		4.60	0.173		0.181
B	0.61		0.88	0.024		0.035
C	0.46		0.70	0.018		0.028
C2	1.21		1.32	0.048		0.052
C3	2.40		2.72	0.094		0.107
D	8.60		9.70	0.339		0.382
E	9.80		10.4	0.386		0.409
F	6.55		6.95	0.258		0.274
G		2.54			0.1	
H	28.0		29.8	1.102		1.173
L1		3.75			0.148	
L2	1.14		1.70	0.045		0.067
L3	2.65		2.95	0.104		0.116
V1		45°			45°	

### TO-220B Package Mechanical Data

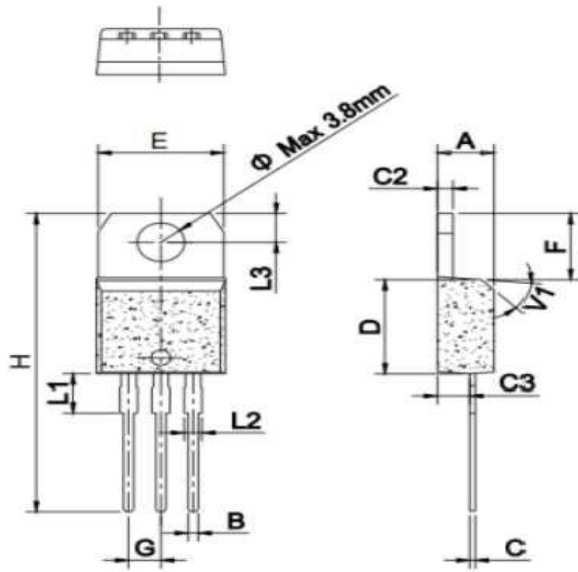

Ref.	Dimensions					
	Millimeters			Inches		
	Min.	Typ.	Max.	Min.	Typ.	Max.
A	4.10		4.30	0.173		0.181
B	0.61		0.88	0.024		0.035
C	0.46		0.70	0.018		0.028
D	1.21		1.32	0.048		0.052
E	2.40		2.72	0.094		0.107
F	8.60		9.70	0.339		0.382
G	9.60		10.4	0.378		0.409
H	6.25		7.05	0.244		0.260
J		2.54			0.1	
K	28.0		29.8	1.102		1.173
N					0.148	
P	1.14		1.70	0.045		0.067
V	2.65		2.95	0.104		0.116

### TO-220F Package Mechanical Data

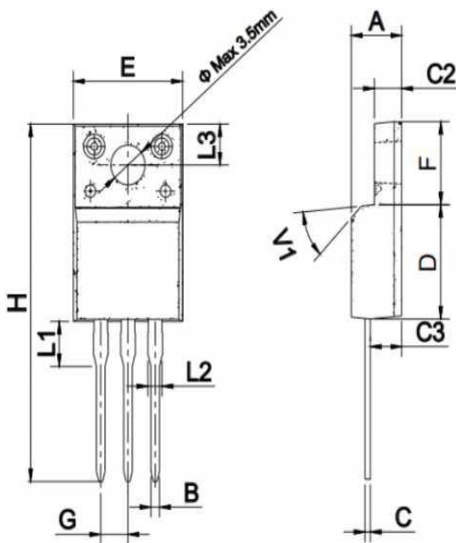

Ref.	Dimensions					
	Millimeters			Inches		
	Min.	Typ.	Max.	Min.	Typ.	Max.
A	4.50		4.90	0.177		0.193
B	0.74	0.80	0.83	0.029	0.031	0.033
C	0.47		0.65	0.019		0.026
C2	2.50		3.10	0.096		0.108
C3	2.40		2.80	0.102		0.118
D	8.60		8.90	0.346		0.366
E	9.80		10.4	0.386		0.410
F	6.70		7.50	0.252		0.268
G		2.54			0.1	
H	28.0		29.8	1.102		1.173
L1		3.63			0.143	
L2	1.14		1.70	0.045		0.067
L3		3.30			0.130	
V1		45°			45°	

### TO-251 Package Mechanical Data

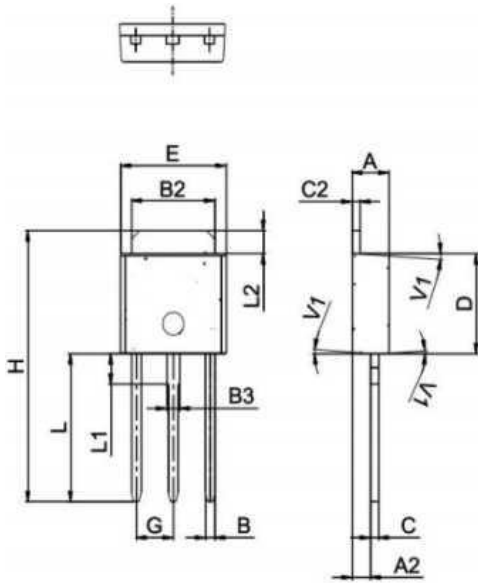

Ref.	Dimensions					
	Millimeters			Inches		
	Min.	Typ.	Max.	Min.	Typ.	Max.
A	2.20		2.40	0.086		0.095
A2	0.90		1.50	0.035		0.059
B	0.55		0.65	0.022		0.026
B2	5.10		5.40	0.200		0.213
B3	0.76		0.85	0.030		0.033
C	0.45		0.62	0.018		0.024
C2	0.66		0.94	0.025		0.037
D	6.00		6.20	0.236		0.244
E	6.40		6.70	0.252		0.264
G		2.30				
H	15.25		15.65	0.600		0.616
L	7.8		8.8	0.307		0.346
L1	1.50		1.90	0.059		0.075
L2	1.10		1.50	0.043		0.059
V1		4			4	

### TO-252 Package Mechanical Data

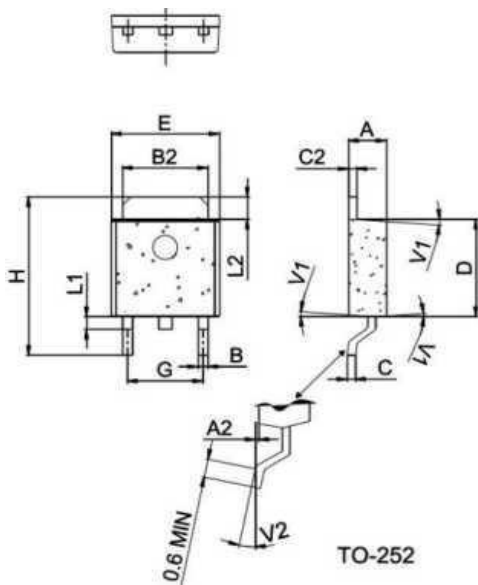

Ref.	Dimensions					
	Millimeters			Inches		
	Min.	Typ.	Max.	Min.	Typ.	Max.
A	2.20		2.40	0.086		0.095
A2	0.03		0.23	0.001		0.009
B	0.55		0.65	0.022		0.026
B2	5.10		5.40	0.200		0.213
C	0.45		0.62	0.018		0.024
C2	0.71		0.99	0.019		0.024
D	6.00		6.20	0.236		0.244
E	6.40		6.70	0.252		0.264
G	4.40		4.70	0.173		0.185
H	9.35		10.60	0.368		0.417
L1	1.30		1.70	0.051		0.067
L2	1.37		1.50	0.054		0.059
V1		4				
V2	0		8	0		8

FIG.1 Maximum power dissipation versus on-state current

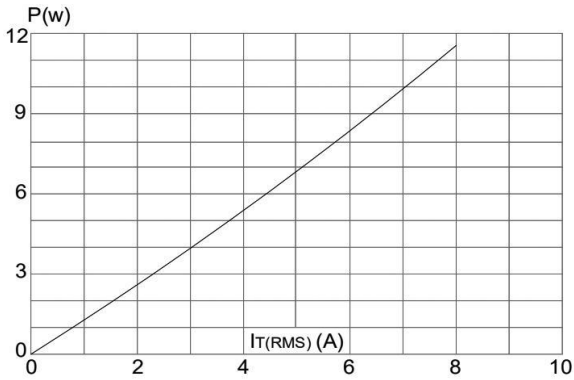

FIG.2: on-state current versus case temperature

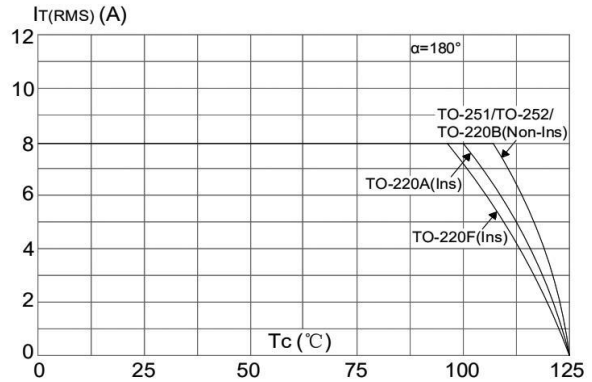

FIG.3: Surge peak on-state current versus number of cycles

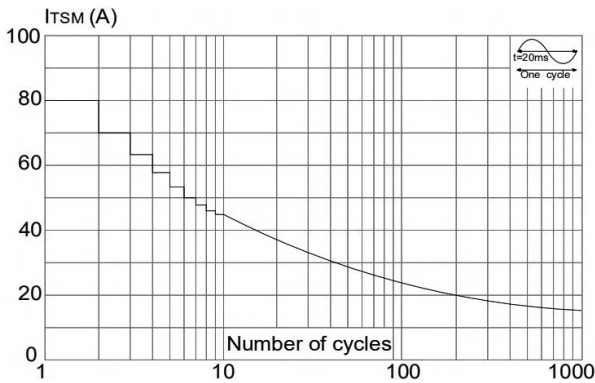

FIG.4: On-state characteristics (maximum values)

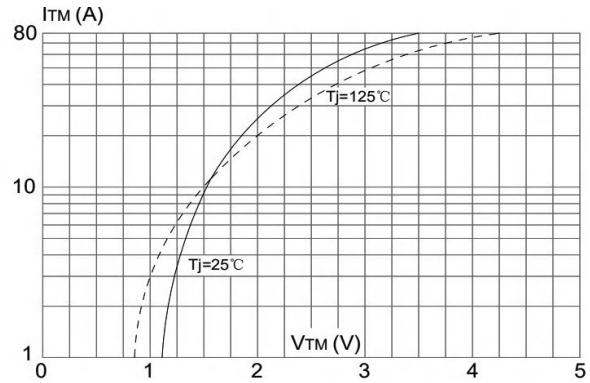

FIG.5: Non-repetitive surge peak on-state current for a sinusoidal pulse with width  $t_p < 10\text{ms}$ , and corresponding value of  $I_2 t$  ( $di/dt < 50\text{A}/\mu\text{s}$ )

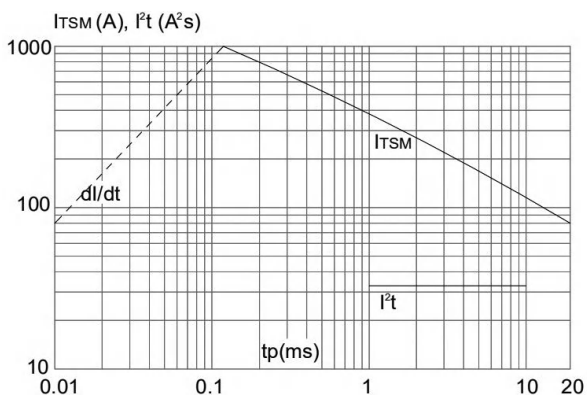
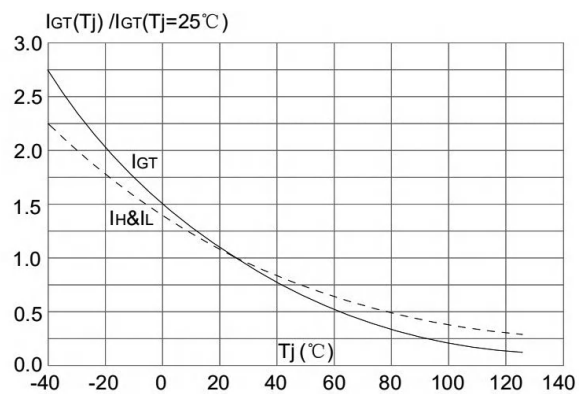

FIG.6: Relative variations of gate trigger current holding current and latching current versus junction temperature



## Disclaimer

All product specifications and data are subject to change without notice.

For documents and material available from this datasheet, Jiangsu Jilai Microelectronics Co., Ltd does not warrant or assume any legal liability or responsibility for the accuracy, completeness of any product or technology disclosed hereunder.

No license, express or implied, by estoppels or otherwise, to any intellectual property rights is granted by this document or by any conduct of Jiangsu Jilai Microelectronics Co., Ltd

The products shown herein are not designed for use in medical, life-saving, or life-sustaining applications unless. Customers using or selling Jiangsu Jilai Microelectronics Co., Ltd products not expressly indicated for use in such applications do so entirely at their own risk and agree to fully indemnify Jiangsu Jilai Microelectronics Co., Ltd for any damages arising or resulting from such use or sale.

Jiangsu Jilai Microelectronics Co., Ltd disclaims any and all liability arising out of the use or application of any product described herein or of any information provided herein to the maximum extent permitted by law. The product specifications do not expand or otherwise modify Jiangsu Jilai Microelectronics Co., Ltd 's terms and conditions of purchase, including but not limited to the warranty expressed therein, which apply to these products.

Jiangsu Jilai Microelectronics Co., Ltd strives to supply high-quality high-reliability products. However, any and all semiconductor products fail with some probability. It is possible that these probabilistic failures could give rise to accidents or events that could endanger human lives that could give rise to smoke or fire, or that could cause damage to other property. When designing equipment, adopt safety measures so that these kinds of accidents or events cannot occur. Such measures include but are not limited to protective circuits and error prevention circuits for safe design, redundant design, and structural design.

In the event that any or all Jiangsu Jilai Microelectronics Co., Ltd products(including technical data, services) described or contained herein are controlled under any of applicable local export control laws and regulations, such products must not be exported without obtaining the export license from the authorities concerned in accordance with the above law.

Information (including circuit diagrams and circuit parameters) herein is for example only; it is not guaranteed for volume production. Jiangsu Jilai Microelectronics Co., Ltd believes information herein is accurate and reliable, but no guarantees are made or implied regarding its use or any infringements of intellectual property rights or other rights of third parties.