

T1G4005528-FS

55W, 28V, DC – 3.5GHz, GaN RF Power Transistor



Applications

- Military radar
- Civilian radar
- Professional and military radio communications
- Test instrumentation
- Avionics
- Wideband or narrowband amplifiers



Product Features

- Frequency: DC to 3.5 GHz
- Linear Gain: >15 dB at 3.5 GHz
- Operating Voltage: 28 V
- Output Power (P_{3dB}): 55 W at 3.5 GHz
- Lead-free and RoHS compliant

Functional Block Diagram

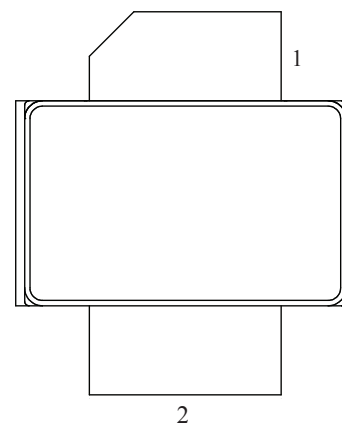

General Description

The TriQuint T1G4005528-FS is a 55 W (P_{3dB}) discrete GaN on SiC HEMT which operates from DC to 3.5 GHz. The device is constructed with TriQuint's proven 0.25 μm production process, which features advanced field plate techniques to optimize power and efficiency at high drain bias operating conditions. This optimization can potentially lower system costs in terms of fewer amplifier line-ups and lower thermal management costs.

Pin Configurations

Pin #	Symbol
1	RF Output
2	RF Input
Flange	Source

Ordering Information

Material No.	Part No.	Description	ECCN
1078974	T1G4005528-FS	Packaged part: Flangeless	EAR99
1079752	T1G4005528-FS-EVB1	3.0-3.5 GHz Eval Brd	EAR99

T1G4005528-FS

55W, 28V, DC – 3.5GHz, GaN RF Power Transistor



Specifications

Absolute Maximum Ratings

Sym	Parameter	Value
V ⁺	Positive Supply Value ¹	28 V
V ⁻	Negative Supply Voltage Range	- 10 V to 0 V
I	Positive Supply Current ¹	4.5 A
I _G	Gate Supply Current	100 mA
P _D	Power Dissipation ¹	61 W
T _{CH}	Operating Channel Temperature ¹	213 °C
BV _{DSX}	Breakdown Voltage	85 V

Notes:

¹ Absolute maximum ratings at 3 GHz.

² Absolute maximum ratings are set based on industry recommended standard mean time to failure (MTTF) greater than 1M hours while operating at a maximum case temperature of 85C . Operating at lower maximum case temperatures allows maximum operating voltage to be increased up to a maximum of 40V. Application specific limits for operating voltage, positive supply current, and power dissipation can be determined with engineering guidance from Triquint.

Electrical Specifications

Recommended operating conditions apply unless otherwise specified: T_A = 25 °C

DC Characteristics

Characteristics	Symbol	Min	Typ	Max	Unit	Conditions
Break-Down Voltage Drain Source	BV _{DSX}	85	120		V	V _{GS} = -8 V, I _D = 10 mA
Gate Quiescent Voltage	V _{GS(O)}		-3.5		V	V _{DS} = 28 V; I _{DQ} = 0.8 A
Gate Threshold Voltage	V _{GS(th)}		-4.5		V	V _{DS} = 10 V; I _D = 40 mA
Saturated Drain Current	I _{DSX}		16		A	V _{DS} = 5 V; V _{GS} = 0 V

RF Characteristics

Characteristics	Symbol	Min	Typ	Max	Unit
Load Pull Performance at 3.0 GHz (V_{DS} = 28 V, I_{DQ} = 200 mA; Pulse: 100µs, 20%)					
Linear Gain	G _{LIN}		17.3		dB
Output Power at 1 dB Gain Compression	P _{1dB}		51.3		W
Drain Efficiency at 1 dB Gain Compression	DE _{1dB}		59.0		%
Power-Added Efficiency at 1 dB Gain Compression	PAE _{1dB}		57.6		%
Gain at 1dB Compression	G _{1dB}		16.3		dB
Load Pull Performance at 3.5 GHz (V_{DS} = 28 V, I_{DQ} = 200 mA; Pulse: 100µs, 20%)					
Linear Gain	G _{LIN}		17.6		dB
Output Power at 1 dB Gain Compression	P _{1dB}		55.0		W
Drain Efficiency at 1 dB Gain Compression	DE _{1dB}		62.1		%
Power-Added Efficiency at 1 dB Gain Compression	PAE _{1dB}		60.7		%
Gain at 1dB Compression	G _{1dB}		16.6		dB
Performance at 3.3 GHz in the 3.0 to 3.5 GHz Eval. Board (V_{DS} = 28 V, I_{DQ} = 200 mA; Pulse: 100 µs, 20%)					
Linear Gain	G _{LIN}	14.0	15.1		dB
Output Power	P _{3dB}	55.0	65.6		W
Drain Efficiency at 3 dB Gain Compression	DE _{3dB}	50.0	52.5		%
Power-Added Efficiency at 3 dB Gain Compression	PAE _{3dB}	45.0	49.3		%
Gain at 3dB Compression	G _{3dB}	11.0	12.1		dB
Narrow Band Performance at 3.5 GHz (V_{DS} = 28 V, I_{DQ} = 200 mA, CW at P1dB, applied for 3.5 secs)					
Impedance Mismatch Ruggedness ³	VSWR		10:1		

Note: ³VSWR testing performed with increasing real impedance value only from reference Z to 10 times reference Z.

T1G4005528-FS

55W, 28V, DC – 3.5GHz, GaN RF Power Transistor



Specifications

Thermal Information

Test Conditions	T _{CH} (°C)	Θ _{JC} (°C/W) ¹
DC at 85°C Case	211	2.1

Notes:

¹ Thermal resistance (channel to backside of case)

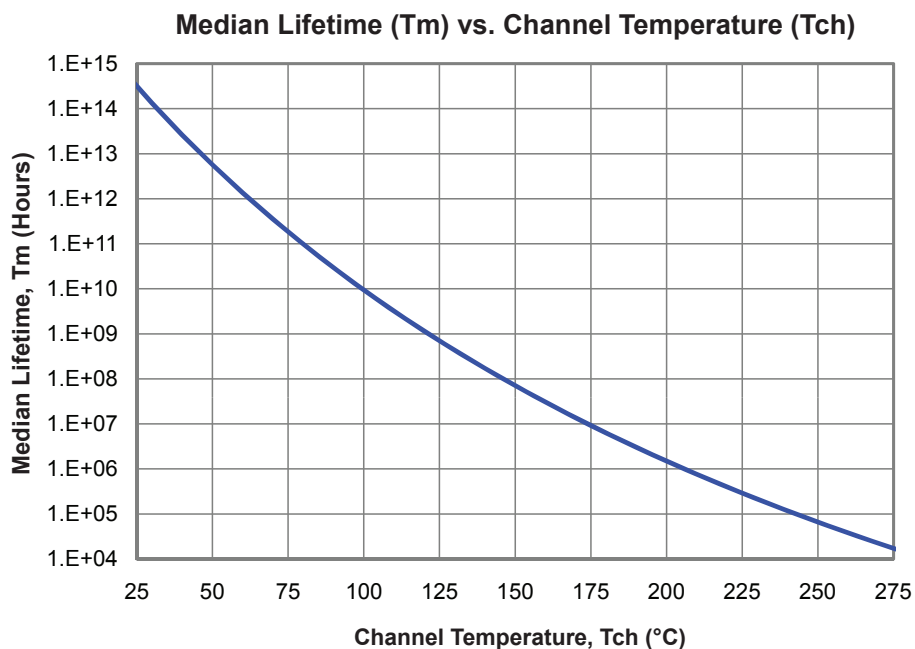
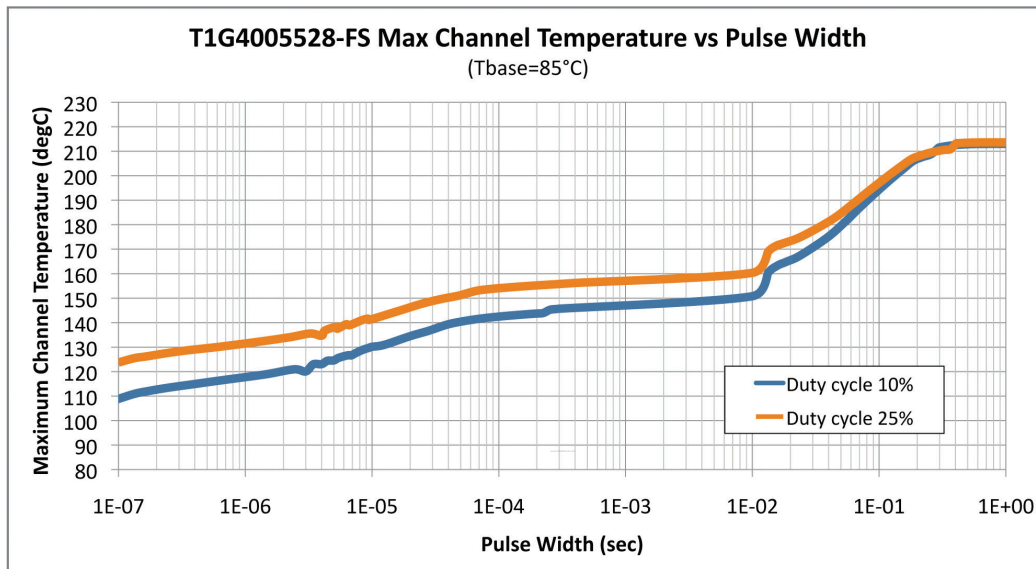

T1G4005528-FS

55W, 28V, DC – 3.5GHz, GaN RF Power Transistor



Device Characterization Data

S-Parameter Smith Chart

T1G4005528-FS
 $V_{DS} = 28V, I_{DQ} = 200\text{ mA}$

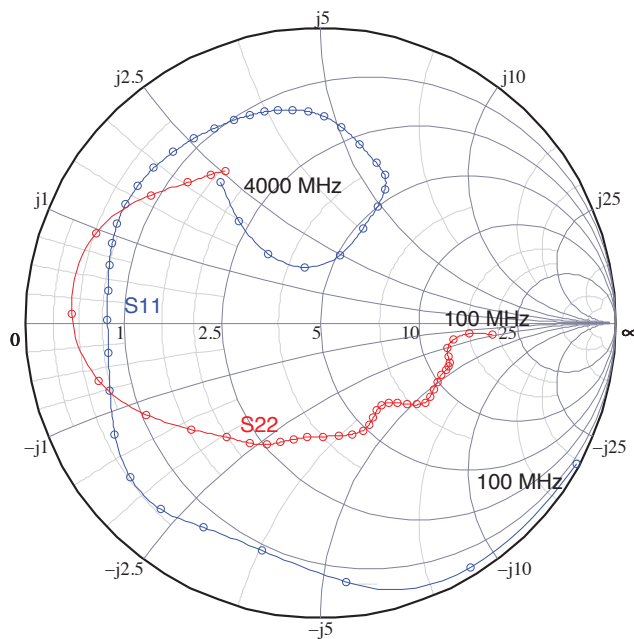

Small-Signal Gain

Maximum Stable Gain of T1G4005528-FS
 $V_{DS} = 28V, I_{DQ} = 200\text{ mA}$

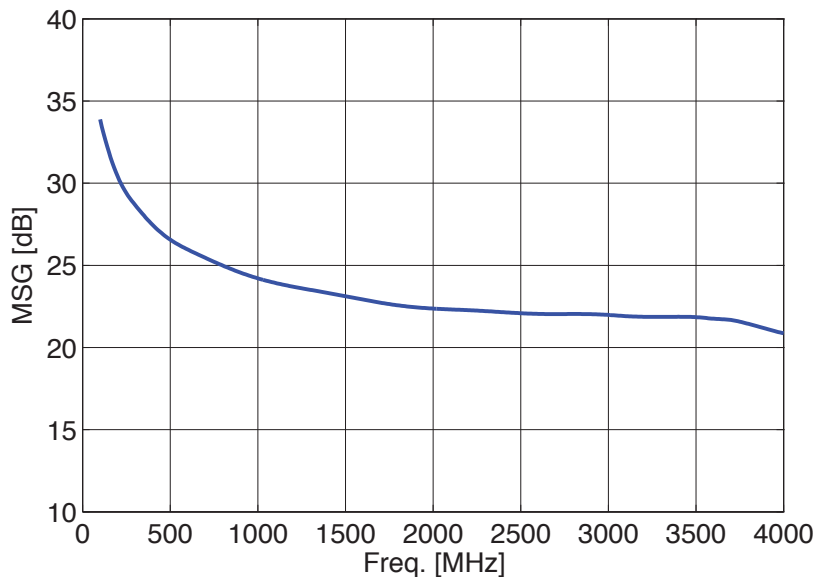

T1G4005528-FS

55W, 28V, DC – 3.5GHz, GaN RF Power Transistor



S-Parameter Data ($V_{DS} = 28V, I_{DQ} = 200\text{ mA}$)

Freq. [GHz]	Real S11	Imag S11	Real S21	Imag S21	Real S12	Imag S12	Real S22	Imag S22
0.1	-0.726	-0.670	-7.178	16.533	0.007	0.003	-0.451	-0.049
0.2	-0.928	-0.342	-1.516	9.124	0.008	0.002	-0.538	-0.035
0.3	-0.950	-0.211	0.151	5.909	0.008	0.001	-0.585	-0.047
0.4	-0.954	-0.146	0.725	4.321	0.008	0.000	-0.605	-0.067
0.5	-0.964	-0.110	0.934	3.517	0.008	0.000	-0.609	-0.088
0.6	-0.974	-0.089	0.969	3.088	0.008	-0.001	-0.610	-0.105
0.7	-0.977	-0.069	0.985	2.697	0.008	-0.001	-0.616	-0.115
0.8	-0.974	-0.049	1.010	2.306	0.008	-0.001	-0.628	-0.120
0.9	-0.971	-0.030	1.042	1.952	0.008	-0.001	-0.643	-0.126
1.0	-0.969	-0.013	1.074	1.667	0.007	-0.001	-0.658	-0.136
1.1	-0.968	0.001	1.100	1.443	0.007	-0.001	-0.673	-0.147
1.2	-0.969	0.014	1.113	1.268	0.007	-0.002	-0.688	-0.157
1.3	-0.970	0.025	1.104	1.129	0.007	-0.002	-0.704	-0.161
1.4	-0.971	0.035	1.070	1.014	0.007	-0.002	-0.718	-0.156
1.5	-0.972	0.044	1.023	0.915	0.006	-0.002	-0.733	-0.145
1.6	-0.971	0.054	0.976	0.826	0.006	-0.002	-0.746	-0.134
1.7	-0.970	0.064	0.945	0.742	0.006	-0.002	-0.759	-0.126
1.8	-0.968	0.075	0.940	0.656	0.006	-0.002	-0.770	-0.124
1.9	-0.964	0.087	0.957	0.571	0.006	-0.002	-0.780	-0.128
2.0	-0.961	0.099	0.984	0.488	0.006	-0.002	-0.790	-0.133
2.1	-0.956	0.111	1.013	0.409	0.006	-0.002	-0.800	-0.138
2.2	-0.952	0.122	1.035	0.336	0.006	-0.003	-0.811	-0.139
2.3	-0.948	0.132	1.042	0.271	0.006	-0.003	-0.825	-0.134
2.4	-0.944	0.141	1.039	0.209	0.006	-0.003	-0.839	-0.126
2.5	-0.939	0.149	1.036	0.145	0.006	-0.003	-0.853	-0.117
2.6	-0.934	0.158	1.039	0.076	0.005	-0.004	-0.866	-0.109
2.7	-0.927	0.167	1.056	-0.006	0.005	-0.004	-0.878	-0.103
2.8	-0.916	0.177	1.087	-0.105	0.005	-0.005	-0.888	-0.099
2.9	-0.900	0.186	1.131	-0.227	0.005	-0.005	-0.898	-0.095
3.0	-0.876	0.192	1.186	-0.379	0.005	-0.006	-0.909	-0.087
3.1	-0.847	0.197	1.231	-0.564	0.004	-0.008	-0.921	-0.076
3.2	-0.828	0.196	1.188	-0.773	0.003	-0.009	-0.938	-0.062
3.3	-0.814	0.185	1.066	-0.990	0.001	-0.009	-0.958	-0.045
3.4	-0.804	0.161	0.856	-1.189	-0.001	-0.009	-0.974	-0.025
3.5	-0.801	0.124	0.533	-1.341	-0.004	-0.009	-0.983	0.003
3.6	-0.812	0.081	0.110	-1.392	-0.006	-0.007	-0.979	0.037
3.7	-0.843	0.056	-0.258	-1.240	-0.008	-0.004	-0.962	0.063
3.8	-0.879	0.058	-0.436	-0.975	-0.008	-0.001	-0.949	0.078
3.9	-0.910	0.072	-0.467	-0.749	-0.007	0.000	-0.940	0.089
4.0	-0.933	0.089	-0.454	-0.571	-0.006	0.001	-0.934	0.096

T1G4005528-FS

55W, 28V, DC – 3.5GHz, GaN RF Power Transistor



Device Characterization Data

Load-Pull Data

RF performance that the device typically exhibits when placed in the specified impedance environment. The impedances are not the impedances of the device, they are the impedances presented to the device via an RF circuit or load-pull system. The impedances listed follow an optimized trajectory to maintain high power and high efficiency (ZLcmp).

Test Conditions: $V_{DS} = 28\text{ V}$, $I_{DQ} = 200\text{ mA}$ **Test Signal:** Pulse Width = 100 μs , Duty Cycle = 20%

Load-Pull Data at 1 GHz

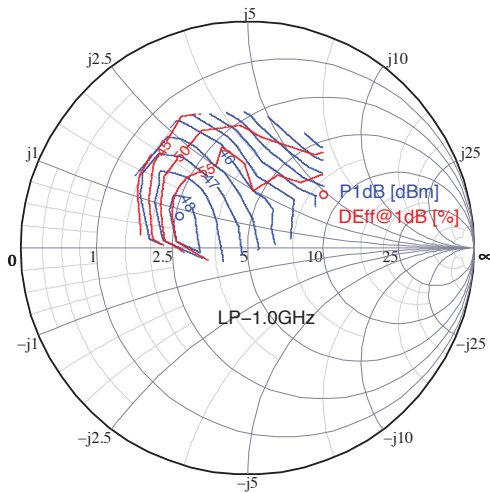

Load-Pull Data at 2 GHz

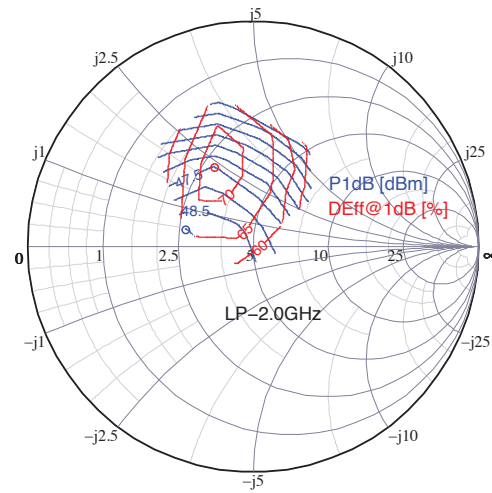

Load-Pull Data at 3 GHz

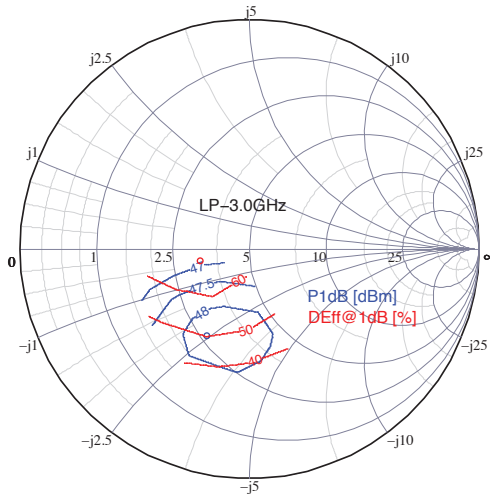

Load-Pull Data at 3.5 GHz

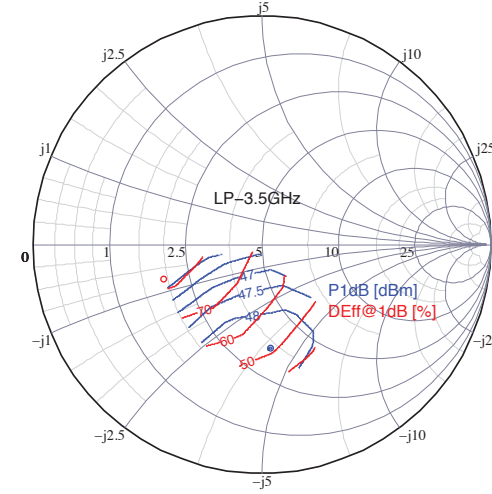

Freq. [GHz]	Real(ZS)	Imag(ZS)	Real(ZL)	Imag(ZL)	G1dB [dB]	P1dB [dBm]	P1dB [W]	DEff1dB [%]	PAE1dB [%]
1.0	0.78	0.94	3.73	0.92	23.1	47.8	59.8	60.8	60.5
2.0	0.90	-2.75	2.70	1.37	18	48.4	68.8	72	70.8
3.0	3.59	-5.46	3.25	-0.90	16.9	47.4	55	63.7	62.4
3.5	7.96	-3.92	3.23	-1.90	17.2	47.7	58.9	65.7	64.4

Note: The higher efficiency at 2GHz is a result of harmonic terminations with the LP test setup.

T1G4005528-FS

55W, 28V, DC – 3.5GHz, GaN RF Power Transistor



Typical Performance: Gain, Efficiency and Output Power

Performance is measured at DUT reference plane

T1G4005528-FS Gain DEff, and PAE vs. Pout

Freq. = 1000 MHz; $V_{DS} = 28V$, $I_{DQ} = 200\text{ mA}$; Pulse: 100 μs , 20%

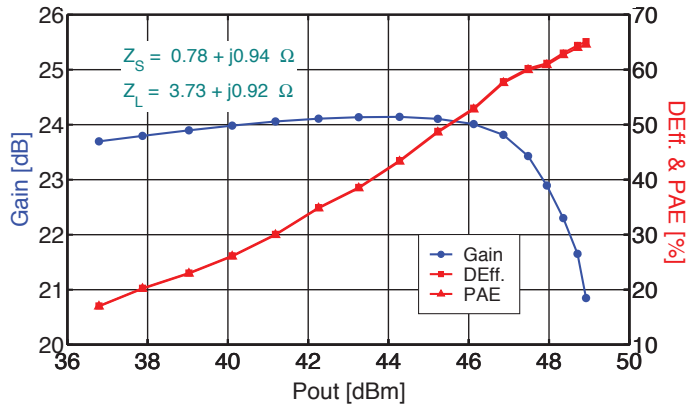

T1G4005528-FS Gain DEff, and PAE vs. Pout

Freq. = 2000 MHz; $V_{DS} = 28V$, $I_{DQ} = 200\text{ mA}$; Pulse: 100 μs , 20%

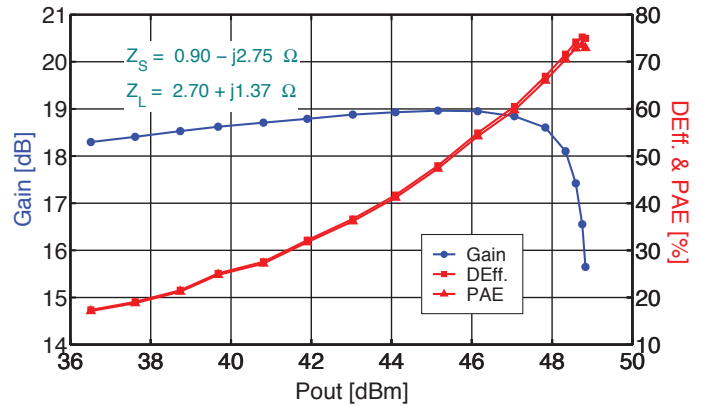

T1G4005528-FS Gain DEff, and PAE vs. Pout

Freq. = 3000 MHz; $V_{DS} = 28V$, $I_{DQ} = 200\text{ mA}$; Pulse: 100 μs , 20%

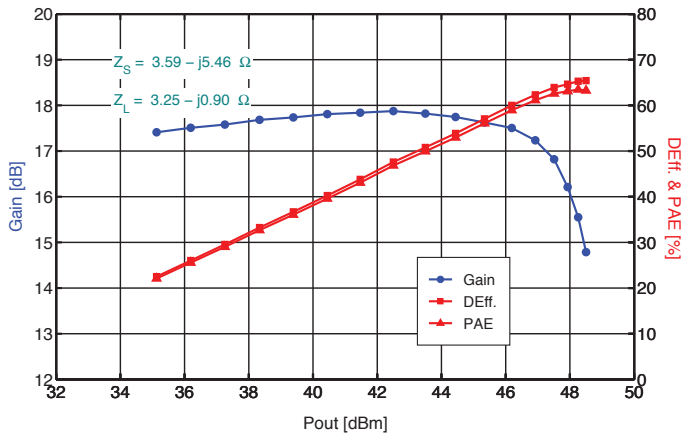

T1G4005528-FS Gain DEff, and PAE vs. Pout

Freq. = 3500 MHz; $V_{DS} = 28V$, $I_{DQ} = 200\text{ mA}$; Pulse: 100 μs , 20%

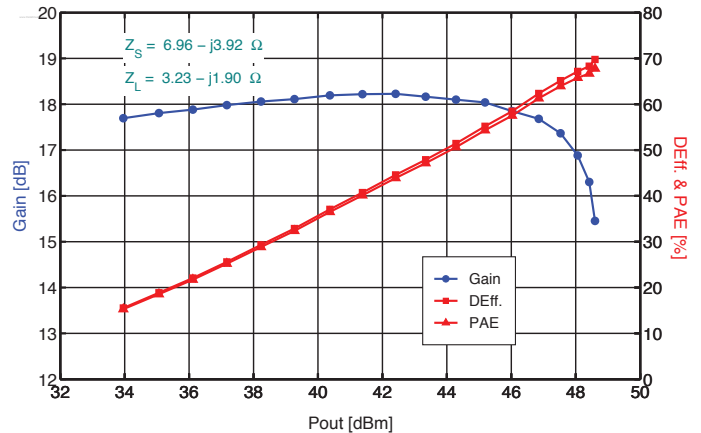

T1G4005528-FS

55W, 28V, DC – 3.5GHz, GaN RF Power Transistor



Performance Over Temperature: Gain, Efficiency and Output Power

Performance measured in TriQuint's 3.0 GHz to 3.5 GHz Evaluation Board at 3 dB compression

T1G4005528-FS Gain vs. Temp.

Freq. = 3300 MHz; $V_{DS} = 28V$, $I_{DQ} = 200\text{ mA}$; Pulse: 100 μs , 20%

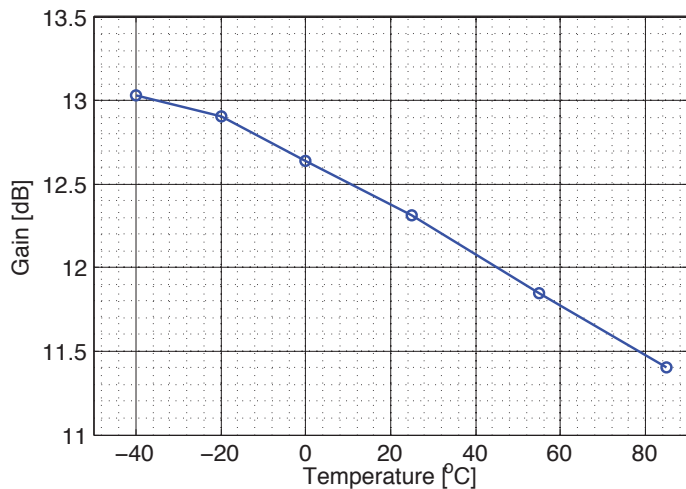

T1G4005528-FS DEff vs. Temp.

Freq. = 3300 MHz; $V_{DS} = 28V$, $I_{DQ} = 200\text{ mA}$; Pulse: 100 μs , 20%

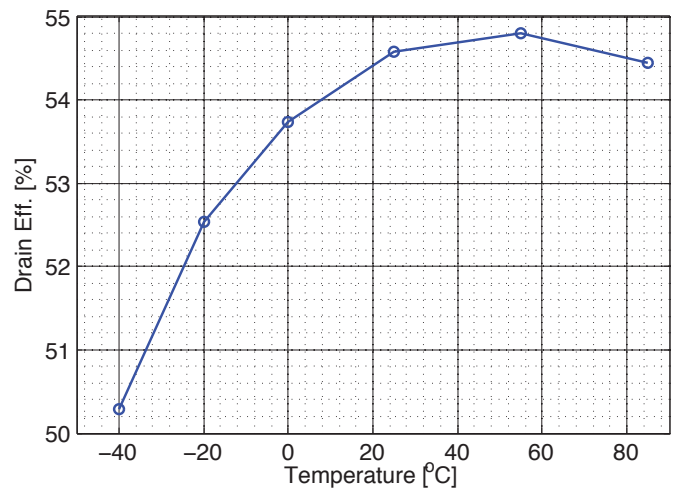

T1G4005528-FS Power vs. Temp.

Freq. = 3300 MHz; $V_{DS} = 28V$, $I_{DQ} = 200\text{ mA}$; Pulse: 100 μs , 20%

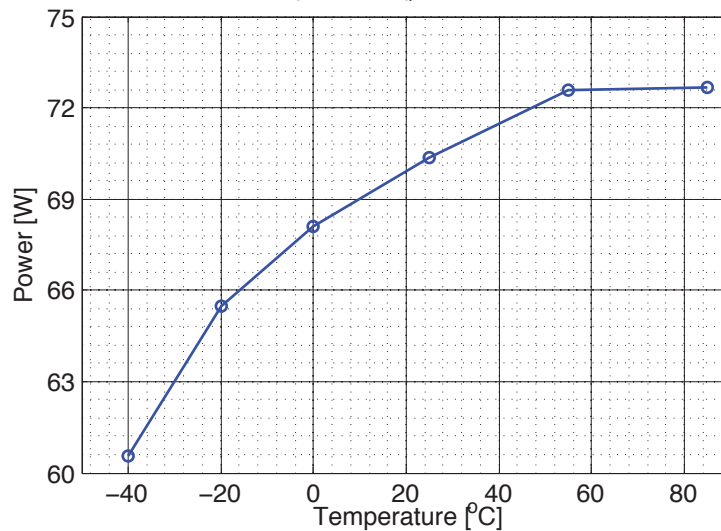

T1G4005528-FS

55W, 28V, DC – 3.5GHz, GaN RF Power Transistor



Evaluation Board Performance

Performance measured in TriQuint's 3.0 GHz to 3.5 GHz Evaluation Board at 3dB compression

T1G4005528-FS EVB Test Data Power vs. Freq.

$V_{DS} = 28V, I_{DQ} = 200\text{ mA}; \text{Pulse: } 100\ \mu\text{s}, 20\%$

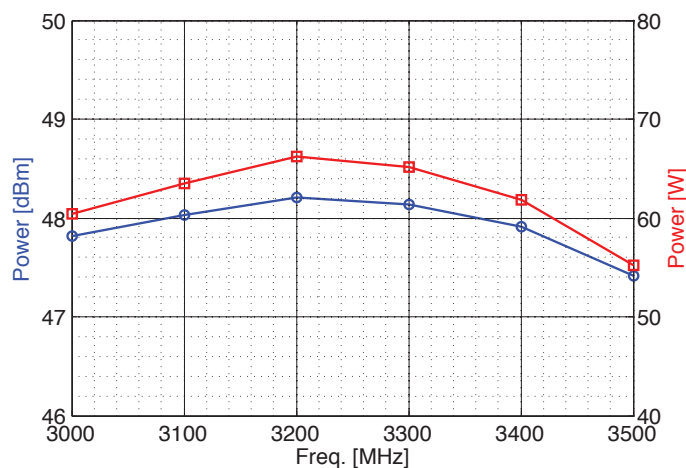

T1G4005528-FS EVB Test Data PAE vs. Freq.

$V_{DS} = 28V, I_{DQ} = 200\text{ mA}; \text{Pulse: } 100\ \mu\text{s}, 20\%$

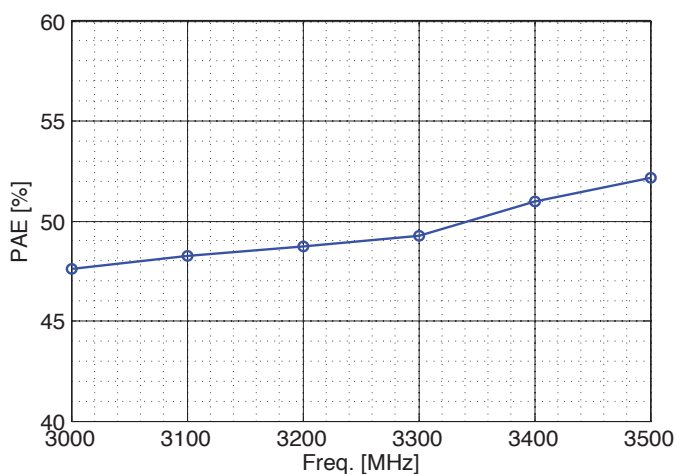

T1G4005528-FS EVB Test Data DEff vs. Freq.

$V_{DS} = 28V, I_{DQ} = 200\text{ mA}; \text{Pulse: } 100\ \mu\text{s}, 20\%$

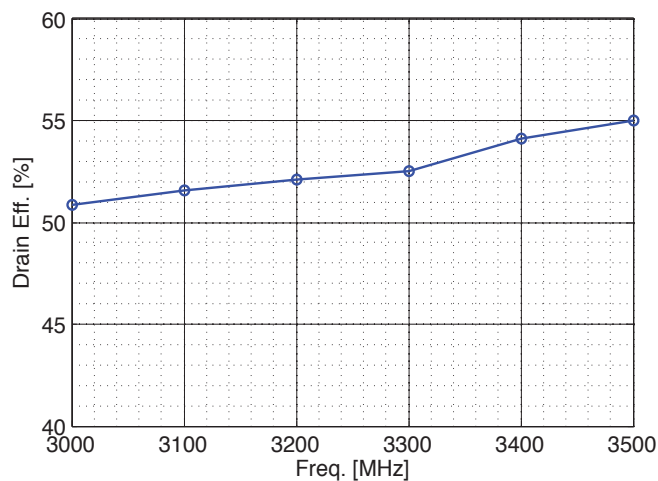

T1G4005528-FS EVB Test Data Gain vs. Freq.

$V_{DS} = 28V, I_{DQ} = 200\text{ mA}; \text{Pulse: } 100\ \mu\text{s}, 20\%$

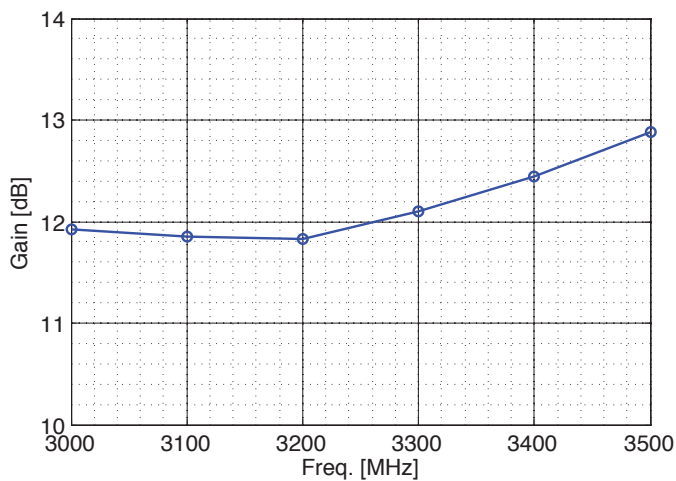

T1G4005528-FS

55W, 28V, DC – 3.5GHz, GaN RF Power Transistor



Evaluation Board Information

PC Board Layout: T1G4005528-FS-EVB1, 3.0 to 3.5 GHz

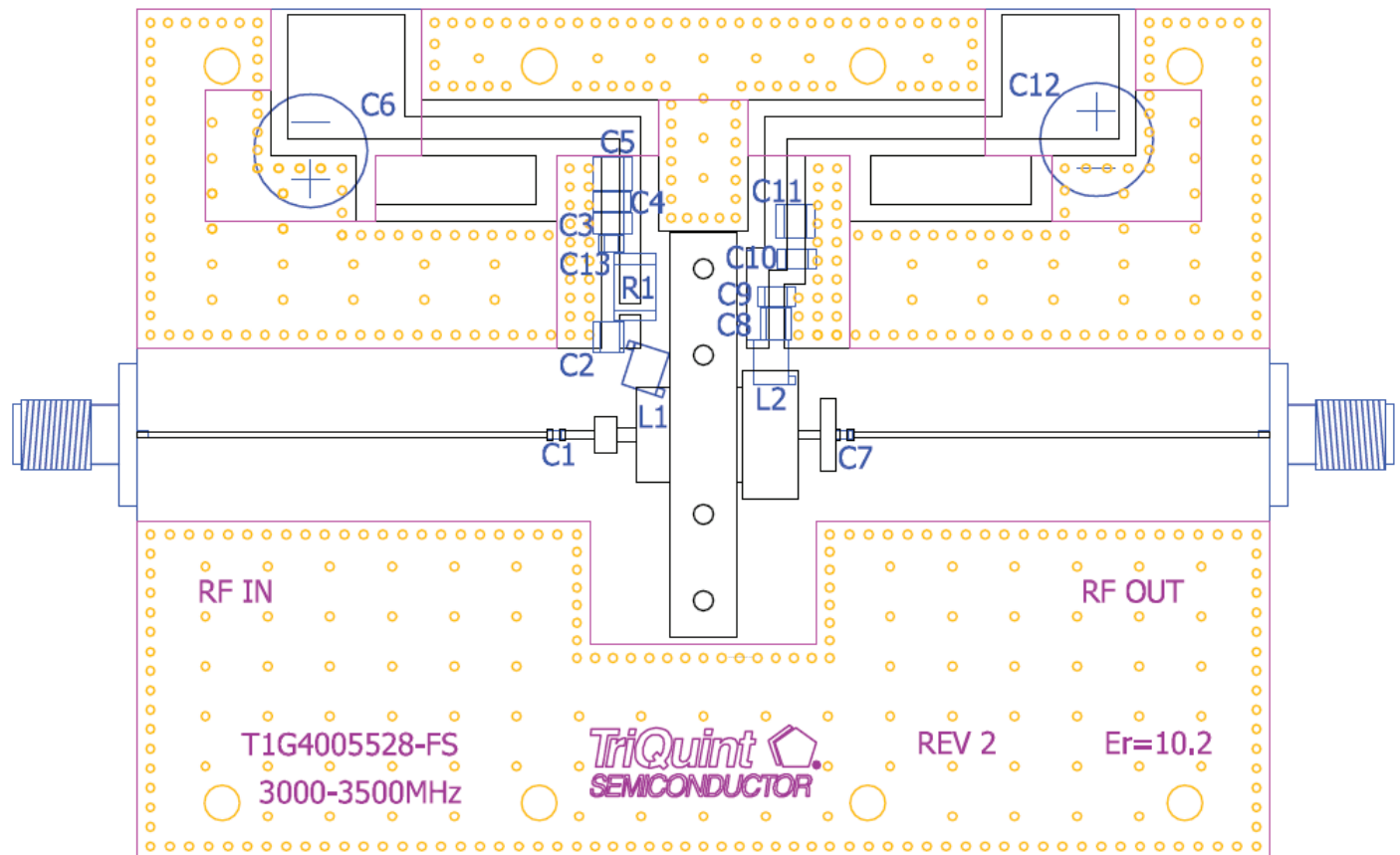

Bill of Materials

Reference Desg.	Value	Qty	Manufacturer	Part Number
C1, C7	47 pF	2	ATC	100A470JW
C2, C8	82 pF	2	ATC	100B820JW
C3, C9	2200 pF	2	Vitramon	VJ1206Y222KRA
C4, C10	22000 pF	2	Vitramon	48C4641
C5, C11	1 uF	2	Allied	213-0366
C6, C12	470 uF	2	Illinois Cap	477KXM035M
L1, L2	12.5 nH	2	Coilcraft	A04T_JL
R1	2.4 Ohm	1	Vishay Dale	CRCW25122R40JNEG
C13	2400 pF	1	Dielectric Labs	C08BL242X-5UN-X0B
PCB	RO3210		Rogers	$\epsilon_r=10.2$ h=25 mil
IMN				Distributed transmission line input network
OMN				Distributed transmission line output network

T1G4005528-FS

55W, 28V, DC – 3.5GHz, GaN RF Power Transistor



Evaluation Board Information (Continued)

T1G4005528-FS-EVB1, 3.0 to 3.5 GHz

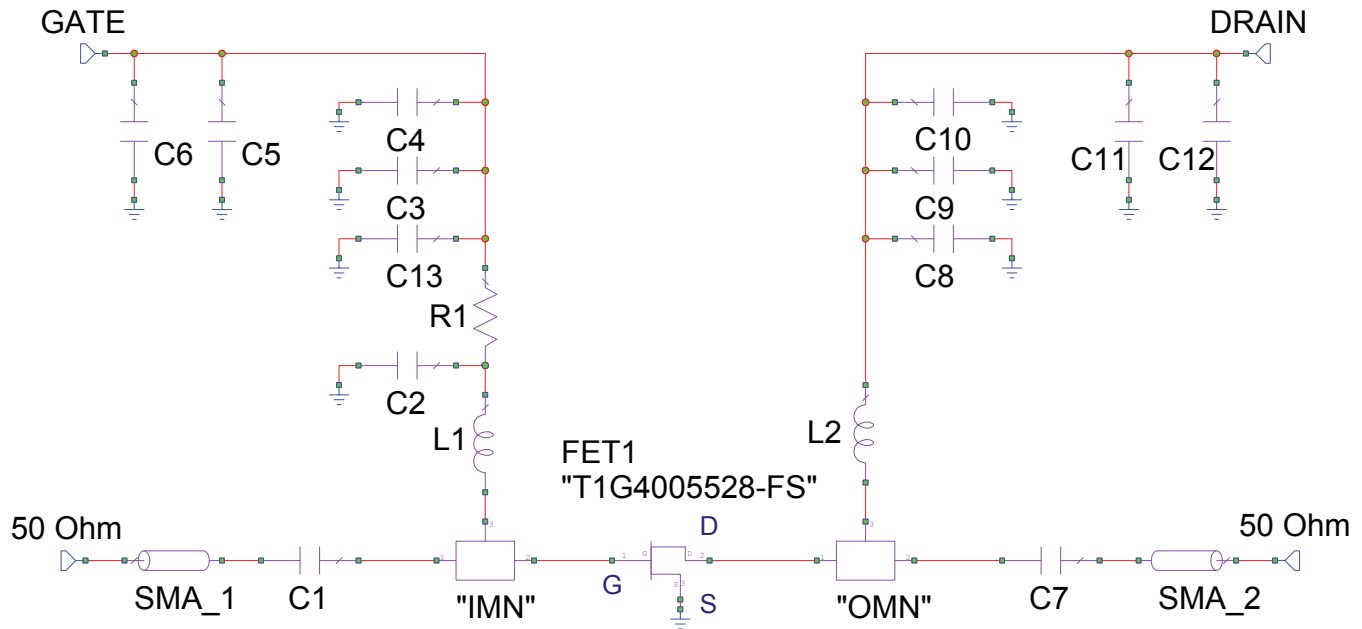

Bias-up Procedure	Bias-down Procedure
Set gate voltage (Vg) to -5.0 V	Turn off RF signal
Set drain voltage (Vd) to 28 V	Turn off Vd and wait 1 second to allow drain capacitor(s) to dissipate
Slowly increase Vg until quiescent Id is 200 mA. Typical Vg is -3.5 V	Turn off Vg
Apply RF signal	

T1G4005528-FS

55W, 28V, DC – 3.5GHz, GaN RF Power Transistor



Mechanical Information

Package Information and Dimensions

This package is lead-free/ROHS-compliant.

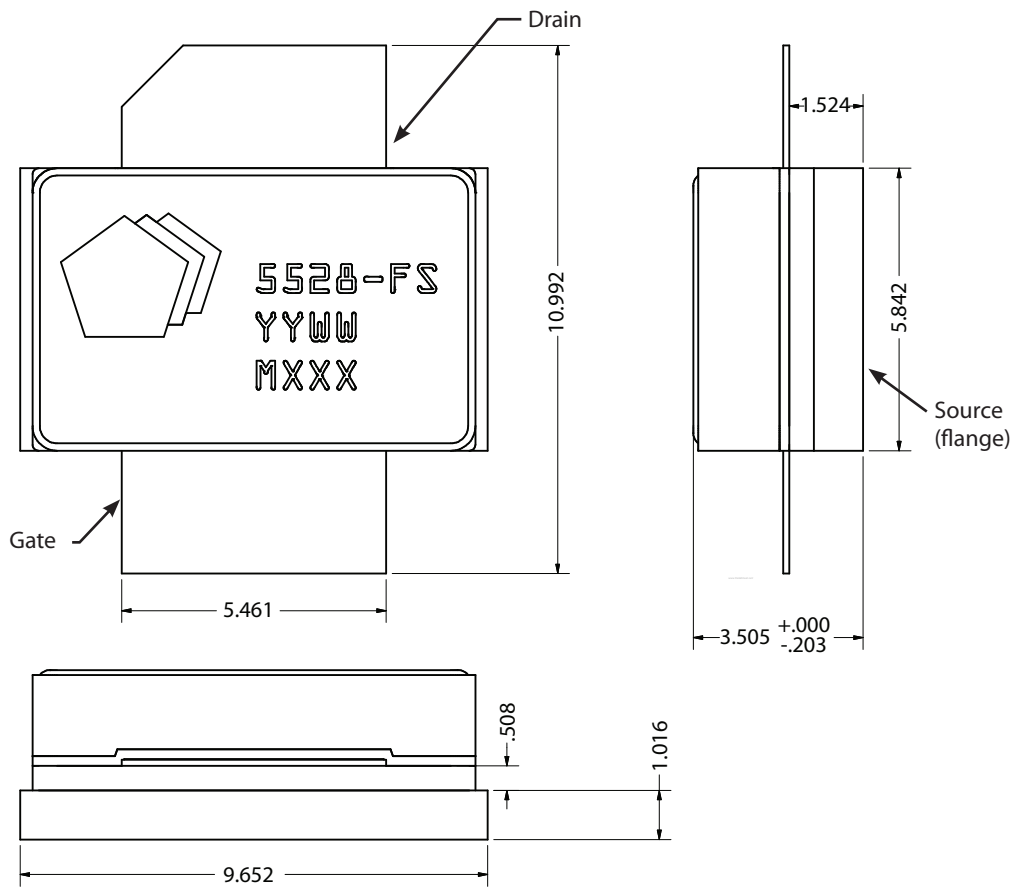

Notes:
Unless specified otherwise,
dimensions are in millimeters

This package is lead-free/RoHS compliant. It is a 9.7 mm x 5.8 mm ceramic air cavity flat lead package and the base material is CuMoCu.

T1G4005528-FS

55W, 28V, DC – 3.5GHz, GaN RF Power Transistor



Product Compliance Information

ESD Information



Caution! ESD-Sensitive Device

ESD Rating: 1A

Value: Passes ≥ 250 V min.

Test: Human Body Model (HBM)

Standard: JEDEC Standard JESD22-A114

MSL Rating

Level 3 at +260 °C convection reflow.

The part is rated Moisture Sensitivity Level 3 at 260°C per JEDEC standard IPC/JEDEC J-STD-020.

ECCN

U.S. Department of Commerce EAR99

Solderability

Compatible with the latest version of J-STD-020, Lead free solder, 260°

This part is compliant with EU 2002/95/EC RoHS directive (Restrictions on the Use of Certain Hazardous Substances in Electrical and Electronic Equipment).

This product also has the following attributes:

- Lead Free
- Halogen Free (Chlorine, Bromine)
- Antimony Free
- TBBP-A (C15H12Br4O2) Free
- PFOS Free
- SVHC Free

T1G4005528-FS

55W, 28V, DC – 3.5GHz, GaN RF Power Transistor



Contact Information

For the latest specifications, additional product information, worldwide sales and distribution locations, and information about TriQuint:

Web: www.triquint.com **Tel:** +1 972.994.8465
Email: info-sales@tqs.com **Fax:** +1 972.994.8504

For technical questions and application information:

Email: info-products@tqs.com

Important Notice

The information contained herein is believed to be reliable. TriQuint makes no warranties regarding the information contained herein. TriQuint assumes no responsibility or liability whatsoever for any of the information contained herein. TriQuint assumes no responsibility or liability whatsoever for the use of the information contained herein. The information contained herein is provided “AS IS, WHERE IS” and with all faults, and the entire risk associated with such information is entirely with the user. All information contained herein is subject to change without notice. Customers should obtain and verify the latest relevant information before placing orders for TriQuint products. The information contained herein or any use of such information does not grant, explicitly or implicitly, to any party any patent rights, licenses, or any other intellectual property rights, whether with regard to such information itself or anything described by such information.

TriQuint products are not warranted or authorized for use as critical components in medical, life-saving, or life-sustaining applications, or other applications where a failure would reasonably be expected to cause severe personal injury or death.