



Product Specification

T215HVN01.0

AU OPTRONICS CORPORATION

() Preliminary Specification

() Final Specification

Module	21.5" Color TFT-LCD
Model Name	T215HVN01.0

Customer	Date
_____	_____
Approved by	
_____	_____
Note: This Specification is subject to change without notice.	

Approved by	Date
<u>Howard Lee</u>	_____
Prepared by	
<u>Eugene Hsu</u>	<u>2012/08/01</u>
AU Optronics Corporation	

Content

1	HANDLING PRECAUTIONS.....	5
2	GENERAL DESCRIPTION.....	6
2.1	Display Characteristics	6
2.2	Optical Characteristics.....	7
3	FUNCTIONAL BLOCK DIAGRAM	11
4	ABSOLUTE MAXIMUM RATINGS	12
4.1	TFT LCD Module	12
4.2	Backlight Unit	12
4.3	Absolute Ratings of Environment.....	12
5	ELECTRICAL CHARACTERISTICS.....	14
5.1	TFT LCD Module	14
5.1.1	Power Specification	14
5.1.2	Signal Electrical Characteristics	15
5.2	Backlight Unit	17
6	SIGNAL CHARACTERISTICS.....	18
6.1	Pixel Format Definition.....	18
6.2	Input Data Format Definition.....	18
6.3	Signal Description.....	19
6.4	Timing Diagram	22
6.5	Power ON/OFF Sequence.....	23
7	CONNECTOR AND PIN ASSIGNMENT	24
7.1	TFT LCD Module	24
7.1.1	Pin Assignment.....	24
7.2	LED Connector on Backlight Unit	25
7.2.1	LED Pin assignment	25
7.2.2	LED Connector Dimension	26
7.2.3	LED Mating housing dimension.....	26
8	RELIABILITY TEST	27
9	SHIPPING LABEL	28
10	MECHANICAL CHARACTERISTICS	29
11	PACKING SPECIFICATION	31
11.1	Packing Flow	31
11.2	Pallet and Shipment Information.....	32

	17	<table border="1"> <thead> <tr> <th>Symbol</th> <th>Description</th> <th>Min.</th> </tr> </thead> <tbody> <tr> <td>IRLED</td> <td>LED Operation Current</td> <td>-</td> </tr> <tr> <td>VLB</td> <td>Light Bar Operation Voltage (for reference)</td> <td>-</td> </tr> </tbody> </table>	Symbol	Description	Min.	IRLED	LED Operation Current	-	VLB	Light Bar Operation Voltage (for reference)	-	Add Min value of Light Bar Operation Voltage	<table border="1"> <thead> <tr> <th>Symbol</th> <th>Description</th> <th>Min.</th> </tr> </thead> <tbody> <tr> <td>IRLED</td> <td>LED Operation Current</td> <td>-</td> </tr> <tr> <td>VLB</td> <td>Light Bar Operation Voltage (for reference)</td> <td>54.4</td> </tr> </tbody> </table>	Symbol	Description	Min.	IRLED	LED Operation Current	-	VLB	Light Bar Operation Voltage (for reference)	54.4																										
Symbol	Description	Min.																																														
IRLED	LED Operation Current	-																																														
VLB	Light Bar Operation Voltage (for reference)	-																																														
Symbol	Description	Min.																																														
IRLED	LED Operation Current	-																																														
VLB	Light Bar Operation Voltage (for reference)	54.4																																														
2012/08/27	6	<table border="1"> <thead> <tr> <th>Physical Size</th> <th>(mm)</th> <th>556.0 (W) x 323.2 (H) x 10.6 (D) (TYP.)</th> </tr> </thead> <tbody> <tr> <td>Physical Size</td> <td>(mm)</td> <td>495.6 (W) * 292.2 (H) * 10.6 (D) (TYP.)</td> </tr> </tbody> </table>	Physical Size	(mm)	556.0 (W) x 323.2 (H) x 10.6 (D) (TYP.)	Physical Size	(mm)	495.6 (W) * 292.2 (H) * 10.6 (D) (TYP.)	Modify Physical Size																																							
Physical Size	(mm)	556.0 (W) x 323.2 (H) x 10.6 (D) (TYP.)																																														
Physical Size	(mm)	495.6 (W) * 292.2 (H) * 10.6 (D) (TYP.)																																														
	17	<table border="1"> <thead> <tr> <th>Symbol</th> <th>Description</th> <th>Min.</th> </tr> </thead> <tbody> <tr> <td>IRLED</td> <td>LED Operation Current</td> <td>-</td> </tr> <tr> <td>VLB</td> <td>Light Bar Operation Voltage (for reference)</td> <td>54.4</td> </tr> </tbody> </table>	Symbol	Description	Min.	IRLED	LED Operation Current	-	VLB	Light Bar Operation Voltage (for reference)	54.4	Update Min. of Light Bar Operation Voltage	<table border="1"> <thead> <tr> <th>Symbol</th> <th>Description</th> <th>Min.</th> </tr> </thead> <tbody> <tr> <td>IRLED</td> <td>LED Operation Current</td> <td>-</td> </tr> <tr> <td>VLB</td> <td>Light Bar Operation Voltage (for reference)</td> <td>51</td> </tr> </tbody> </table>	Symbol	Description	Min.	IRLED	LED Operation Current	-	VLB	Light Bar Operation Voltage (for reference)	51																										
Symbol	Description	Min.																																														
IRLED	LED Operation Current	-																																														
VLB	Light Bar Operation Voltage (for reference)	54.4																																														
Symbol	Description	Min.																																														
IRLED	LED Operation Current	-																																														
VLB	Light Bar Operation Voltage (for reference)	51																																														
	12	<table border="1"> <thead> <tr> <th>Item</th> <th>Symbol</th> <th>Min</th> <th>Max</th> </tr> </thead> <tbody> <tr> <td rowspan="4">LED Forward Current</td> <td>IRLED1</td> <td rowspan="4">0</td> <td rowspan="4">90</td> </tr> <tr> <td>IRLED2</td> </tr> <tr> <td>IRLED3</td> </tr> <tr> <td>IRLED4</td> </tr> <tr> <td rowspan="4">LED Pulse Forward Current</td> <td>IPLED1</td> <td rowspan="4">-</td> <td rowspan="4">150</td> </tr> <tr> <td>IPLED2</td> </tr> <tr> <td>IPLED3</td> </tr> <tr> <td>IPLED4</td> </tr> <tr> <td>LED forward Voltage variation (per string variation)</td> <td>ΔV_f</td> <td>-</td> <td>13.6</td> </tr> </tbody> </table>	Item	Symbol	Min	Max	LED Forward Current	IRLED1	0	90	IRLED2	IRLED3	IRLED4	LED Pulse Forward Current	IPLED1	-	150	IPLED2	IPLED3	IPLED4	LED forward Voltage variation (per string variation)	ΔV_f	-	13.6	Update Max of LED forward Voltage variation	<table border="1"> <thead> <tr> <th>Item</th> <th>Symbol</th> <th>Min</th> <th>Max</th> </tr> </thead> <tbody> <tr> <td rowspan="4">LED Forward Current</td> <td>IRLED1</td> <td rowspan="4">0</td> <td rowspan="4">90</td> </tr> <tr> <td>IRLED2</td> </tr> <tr> <td>IRLED3</td> </tr> <tr> <td>IRLED4</td> </tr> <tr> <td rowspan="4">LED Pulse Forward Current</td> <td>IPLED1</td> <td rowspan="4">-</td> <td rowspan="4">150</td> </tr> <tr> <td>IPLED2</td> </tr> <tr> <td>IPLED3</td> </tr> <tr> <td>IPLED4</td> </tr> <tr> <td>LED forward Voltage variation (per string variation)</td> <td>ΔV_f</td> <td>-</td> <td>3.4</td> </tr> </tbody> </table>	Item	Symbol	Min	Max	LED Forward Current	IRLED1	0	90	IRLED2	IRLED3	IRLED4	LED Pulse Forward Current	IPLED1	-	150	IPLED2	IPLED3	IPLED4	LED forward Voltage variation (per string variation)	ΔV_f	-	3.4
Item	Symbol	Min	Max																																													
LED Forward Current	IRLED1	0	90																																													
	IRLED2																																															
	IRLED3																																															
	IRLED4																																															
LED Pulse Forward Current	IPLED1	-	150																																													
	IPLED2																																															
	IPLED3																																															
	IPLED4																																															
LED forward Voltage variation (per string variation)	ΔV_f	-	13.6																																													
Item	Symbol	Min	Max																																													
LED Forward Current	IRLED1	0	90																																													
	IRLED2																																															
	IRLED3																																															
	IRLED4																																															
LED Pulse Forward Current	IPLED1	-	150																																													
	IPLED2																																															
	IPLED3																																															
	IPLED4																																															
LED forward Voltage variation (per string variation)	ΔV_f	-	3.4																																													

1 Handling Precautions

- 1) Since front polarizer is easily damaged, pay attention not to scratch it.
- 2) Be sure to turn off power supply when inserting or disconnecting from input connector.
- 3) Wipe off water drop immediately. Long contact with water may cause discoloration or spots.
- 4) When the panel surface is soiled, wipe it with absorbent cotton or other soft cloth.
- 5) Since the panel is made of glass, it may break or crack if dropped or bumped on hard surface.
- 6) Since CMOS LSI is used in this module, take care of static electricity and insure human earth when handling.
- 7) Do not open or modify the Module Assembly.
- 8) Do not press the reflector sheet at the back of the module to any directions.
- 9) In case if a Module has to be put back into the packing container slot after once it was taken out from the container, do not press the center of LED light bar edge. Instead, press at the far ends of the LED light bar edge softly. Otherwise the TFT Module may be damaged.
- 10) At the insertion or removal of the Signal Interface Connector, be sure not to rotate nor tilt the Interface Connector of the TFT Module.
- 11) After installation of the TFT Module into an enclosure, do not twist nor bend the TFT Module even momentary. At designing the enclosure, it should be taken into consideration that no bending/twisting forces are applied to the TFT Module from outside. Otherwise the TFT Module may be damaged.
- 12) Small amount of materials having no flammability grade is used in the LCD module. The LCD module should be supplied by power complied with requirements of Limited Power Source (IEC60950 or UL1950), or be applied exemption.
- 13) Avoid touching COF position while doing mechanical design.
- 14) While storing modules as spares for a long time, the following precautions are necessary:
 - Store modules in a dark place. Do not expose them to sunlight or fluorescent light.
 - Keep the temperature between 5°C and 35°C at normal humidity.

2 General Description

This specification applies to the 21.5 inch-FHD color a-Si TFT-LCD Module T215HVN01.0. The display supports the FHD - 1920(H) x 1080(V) screen format and 16.7M colors (RGB 8-bit data). The light source of this TFT-LCD module is W-LED. All input signals are 2-channel LVDS interface and this module doesn't contain a driver for backlight.

2.1 Display Characteristics

The following items are characteristics summary on the table under 25 °C condition:

Items	Unit	Specification
Screen Diagonal	[mm]	546.865(21.53")
Active Area	[mm]	476.64 (H) x 268.11 (V)
Pixels H x V		1920(x3) x 1080
Pixel Pitch	[um]	248.25 (per one triad) x248.25
Pixel Arrangement		R.G.B. Vertical Stripe
Display Mode		VA Mode, Normally Black
White Luminance (Center)	[cd/m2]	250 cd/m2 (Typ.)
Contrast Ratio		3000 (Typ.) (TBD)
Optical Response Time	[msec]	25ms (Typ., on/off) (TBD)
Nominal Input Voltage VDD	[Volt]	+ 5.0 V
Power Consumption (VDD line + LED line)	[Watt]	16.55 watt (VDD line : PDD (typ), All white pattern at 60Hz = 3.45W LED line : PBLU (typ) = 13.1W)
Weight	[g]	1,800 gram (Typ.)
Physical Size	[mm]	495.6 (W) * 292.2 (H) *10.6 (D) (TYP.)
Electrical Interface		Dual channel LVDS
Support Color		16.7M colors (RGB 8-bit)
Surface Treatment		Anti-Glare, 3H
Temperature Range		
Operating	[°C]	0 to +50
Storage (Shipping)	[°C]	-20 to +60
RoHS Compliance		RoHS Compliance
TCO Compliance		TCO 6.0 Compliance

2.2 Optical Characteristics

The optical characteristics are measured under stable conditions at 25°C:

Item	Unit	Conditions	Min.	Typ.	Max.	Note
Viewing Angle	[degree]	Horizontal (Right)	75	89	-	2
		CR = 10 (Left)	75	89	-	
		Vertical (Up)	75	89	-	
		CR = 10 (Down)	75	89	-	
Contrast Ratio		Normal Direction	TBD	TBD	-	3
Response Time	[msec]	Rising Time (TrR)	-	TBD	TBD	4
		Falling Time (TrF)	-	TBD	TBD	
		Rising + Falling	-	TBD	TBD	
Color / Chromaticity Coordinates (CIE)		Red x	0.615	0.645	0.675	5
		Red y	0.304	0.334	0.364	
		Green x	0.283	0.313	0.343	
		Green y	0.606	0.636	0.666-	
		Blue x	0.124	0.154	0.184	
		Blue y	0.014	0.044	0.074	
Color Coordinates (CIE) White		White x	0.283	0.313	0.343	
		White y	0.299	0.329	0.359	
Central Luminance	[cd/m ²]		200	250	-	6
Luminance Uniformity	[%]		75	80	-	7
Crosstalk (in 60Hz)	[%]				TBD	8
Flicker	dB				TBD	9

Note 1: Measurement Method

The LCD module should be stabilized at given temperature for 30 minutes to avoid abrupt temperature change during measuring (at surface 35°C). In order to stabilize the luminance, the measurement should be executed after lighting Backlight for 30 minutes in a stable, windless and dark room.

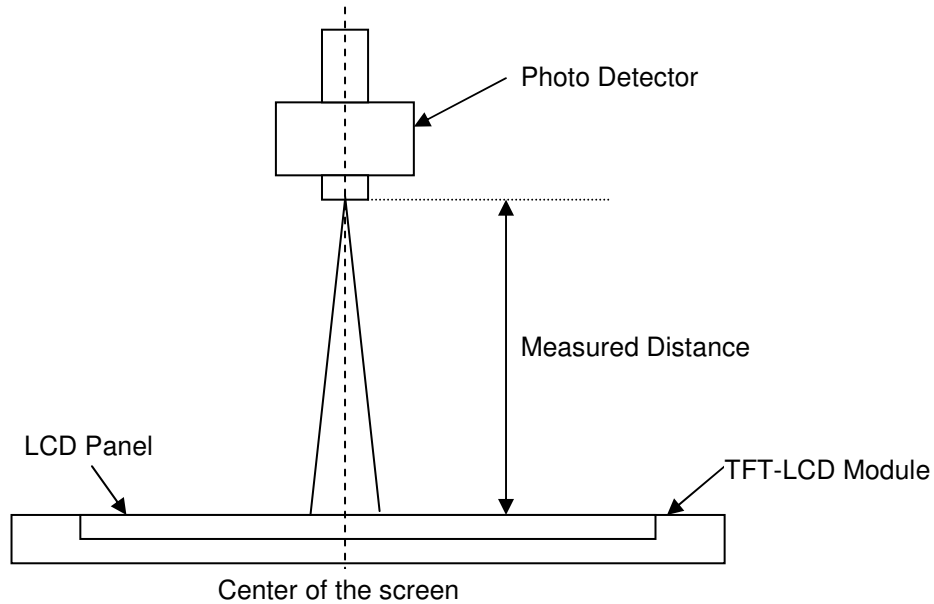

Note 2: Definition of Viewing Angle measured by ELDIM (EZContrast 88)

Viewing angle is the measurement of contrast ratio ≥ 10 , at the screen center, over a 180° horizontal and 180° vertical range (off-normal viewing angles). The 180° viewing angle range is broken down as follows; 90° (θ) horizontal left and right and 90° (Φ) vertical, high (up) and low (down). The measurement direction is typically perpendicular to the display surface with the screen rotated about its center to develop the desired measurement viewing angle.

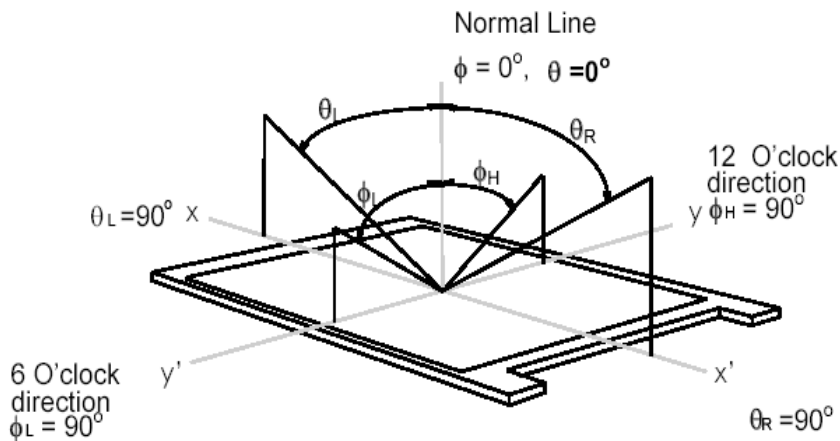

Note 3: Contrast Ratio measured by TOPCON SR-3

Note 4: Definition of Response time measured by Westar TRD-100A

The output signals of photo detector are measured when the input signals are changed from “Full Black” to “Full White” (rising time, T_{rR}), and from “Full White” to “Full Black” (falling time, T_{rF}), respectively. The response time is interval between the 10% and 90% (1 frame at 60 Hz) of amplitudes.

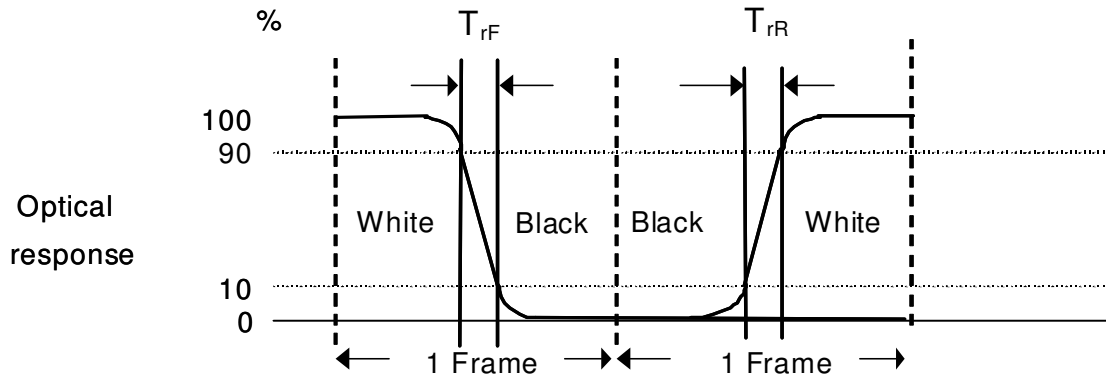

$$T_{rR} + T_{rF} = 5 \text{ msec (typ.)}$$

Note 5: Color Chromaticity and Coordinates (CIE) measured by TOPCON SR-3

Note 6: Central Luminance measured by TOPCON SR-3

Note 7: Luminance Uniformity of these 9 points defined as below and measured by TOPCON SR-3

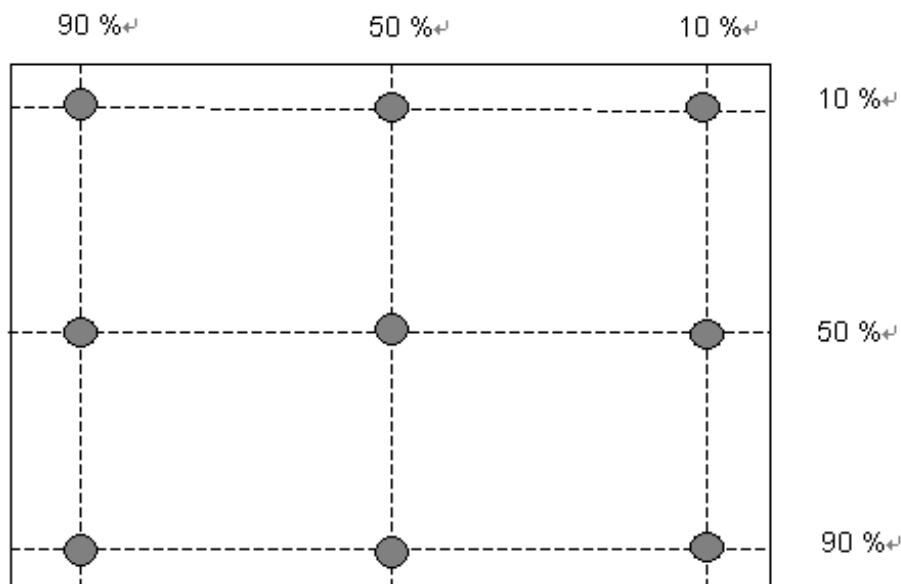

$$\text{Uniformity} = \frac{\text{Minimum Luminance in 9 points (1-9)}}{\text{Maximum Luminance in 9 Points (1-9)}}$$

Note 8: Crosstalk defined as below and measured by TOPCON SR-3

$$CT = | YB - YA | / YA \times 100 (\%)$$

Where

YA = Luminance of measured location without gray level 0 pattern (cd/m²)

YB = Luminance of measured location with gray level 0 pattern (cd/m²)

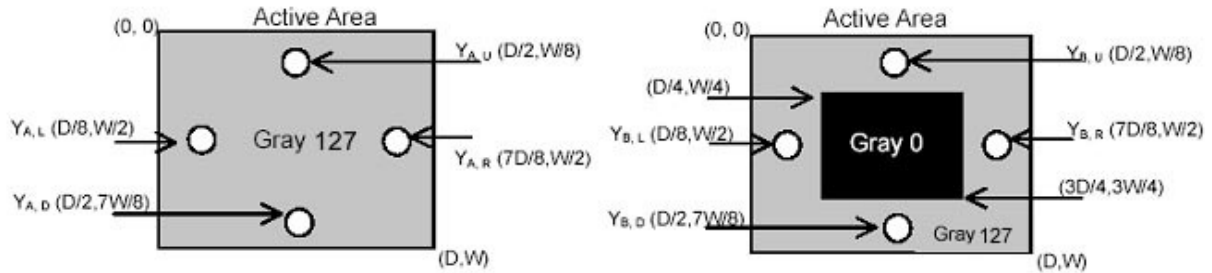

Note 9: Test Pattern Sub-checker Pattern measured by TOPCON SR-3

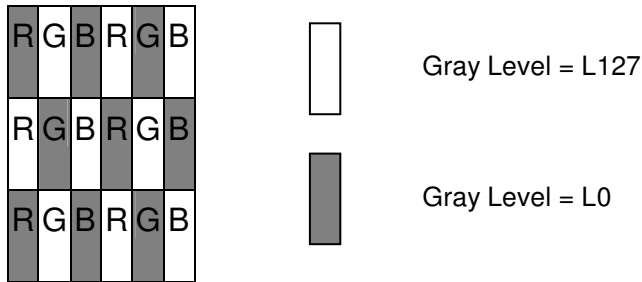

Method: Record dBV & DC value with TRD-100

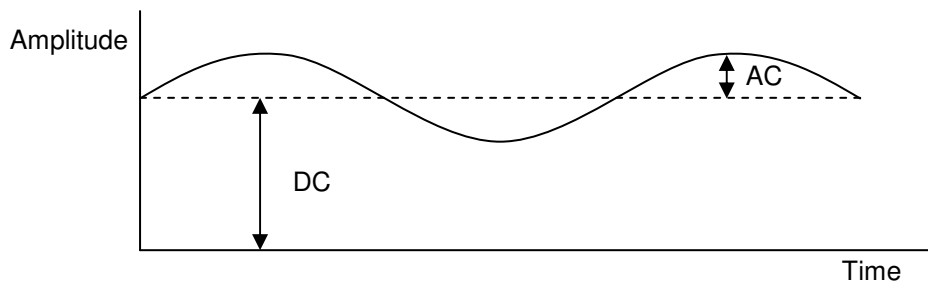

$$\text{Flicker (dB)} = 20 \log \frac{\text{AC Level(at 30 Hz)}}{\text{DC Level}}$$

3 Functional Block Diagram

The following diagram shows the functional block of the 21.5 inch Color TFT-LCD Module:

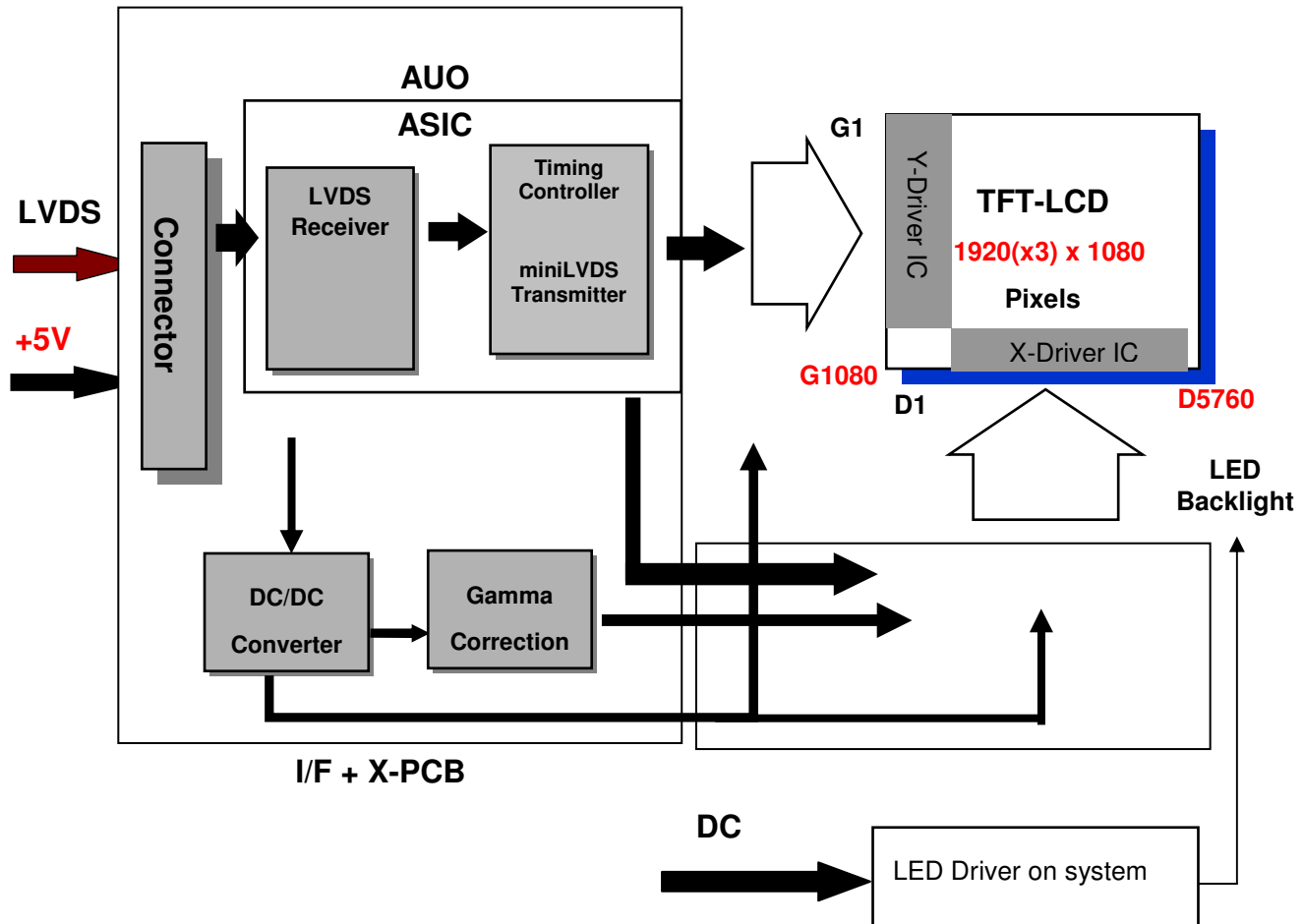

I/F PCB Interface:
 MSCKT2407P30HB
 AL230F-A0G1D-P

Mating Type:

FI-X30HL(Locked Type) (TBD)

4 Absolute Maximum Ratings

Absolute maximum ratings of the module are listed as follows:

4.1 TFT LCD Module

Item	Symbol	Min	Max	Unit	Conditions
Logic/LCD Drive	VDD	-0.3	TBD	[Volt]	Note 1, 2

4.2 Backlight Unit

Item	Symbol	Min	Max	Unit	Conditions
LED Forward Current	IRLED1	0	90	[mA]	Note 1,2,5 100% duty
	IRLED2				
	IRLED3				
	IRLED4				
LED Pulse Forward Current	IPLED1	-	150	[mA]	Note 1,2,5 10% duty @100Hz
	IPLED2				
	IPLED3				
	IPLED4				
LED forward Voltage variation (per string variation)	ΔV_f	-	3.4	[Volt]	Note 1,2

4.3 Absolute Ratings of Environment

Item	Symbol	Min.	Max.	Unit	Conditions
Operating Temperature	TOP	0	+50	[°C]	Note 3
Glass Surface Temperature (Operation)	TGS	0	+65	[°C]	Note3 Note4
Operation Humidity	HOP	5	90	[%RH]	Note 3
Storage Temperature	TST	-20	+60	[°C]	
Storage Humidity	HST	5	90	[%RH]	

Note 1: With in Ta (25 °C)

Note 2: Permanent damage to the device may occur if exceeding maximum values



Note 3: Temperature and relative humidity range are shown as the below figure.

1. 90% RH Max (Ta ≤ 39°C)
2. Max wet-bulb temperature at 39°C or less. (Ta ≤ 39°C)
3. No condensation

Note 4: Function Judged only

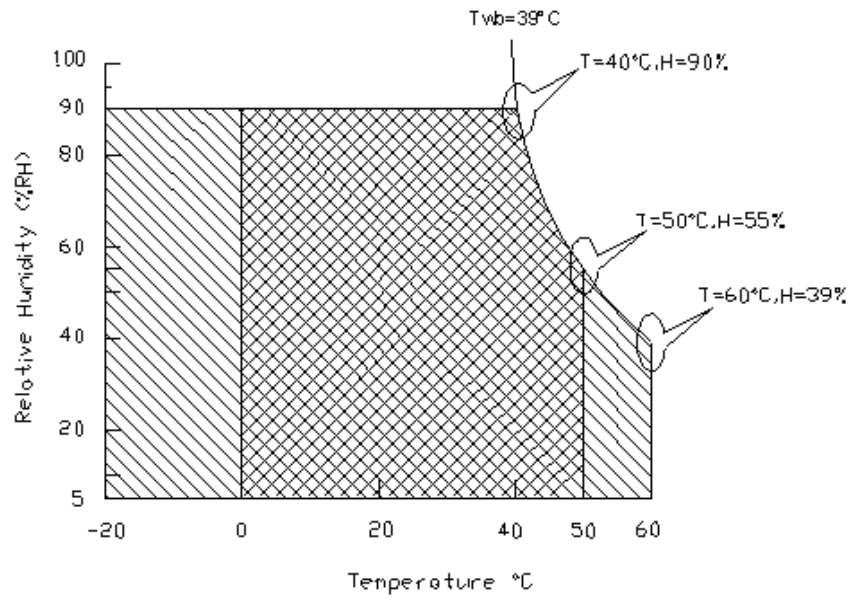
Note 5: IRLED1,2,3,4 and IPLED1,2,3,4 define as per strings LED current.



Operating Range  Storage Range  + 

5 Electrical Characteristics

5.1 TFT LCD Module

5.1.1 Power Specification

Input power specifications are listed as follows:

Symbol	Description	Min	Typ.	Max	Unit	Conditions
VDD	Logic/LCD Drive Voltage	4.5	5.0	5.5	[Volt]	+/-10%
IDD1	Input Current	-	0.69	0.83	[A]	VDD= 5.0V, All White Pattern at 60 Hz
		-	0.8	0.96	[A]	VDD= 5.0V, All White Pattern at 75 Hz
PDD1	VDD Power	-	3.45	4.15	[Watt]	VDD= 5.0V, All White Pattern at 60 Hz
		-	4	4.8	[Watt]	VDD= 5.0V, All White Pattern at 75 Hz
IRush	Inrush Current	-	-	3	[A]	Note 1
VDDrp	Allowable Logic/LCD Drive Ripple Voltage	-	-	500	[mV] p-p	VDD= 5.0V, All White Pattern at 75 Hz

Note 1: Measurement Conditions:

The duration of rising time of power input is 470 us.

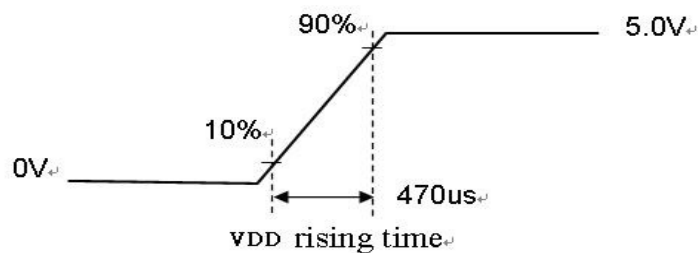
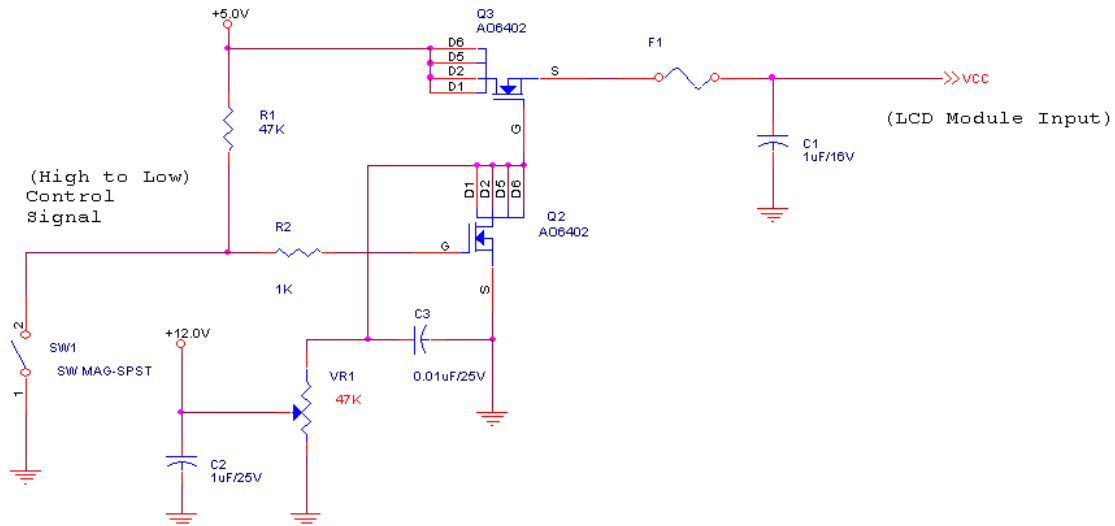

5.1.2 Signal Electrical Characteristics

(1) DC Characteristics of each signal are as following:

Symbol	Description	Min	Typ	Max	Units	Conditions
V_{TH}	Differential Input High Threshold	-	-	+100	[mV]	$V_{CM} = 1.2V$ Note 1
V_{TL}	Differential Input Low Threshold	-100	-	-	[mV]	$V_{CM} = 1.2V$ Note 1
$ V_{ID} $	Input Differential Voltage	100	-	600	[mV]	Note 1
V_{CM}	Differential Input Common Mode Voltage	+1.0	+1.2	+1.5	[V]	$V_{TH}-V_{TL} = 200MV$ (max) Note 1

Note 1: LVDS Signal Waveform

Single-End

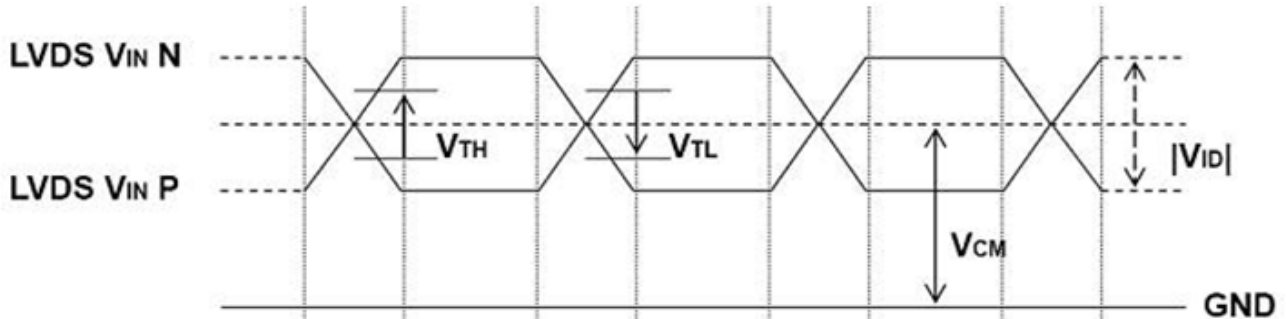

Differential Signal

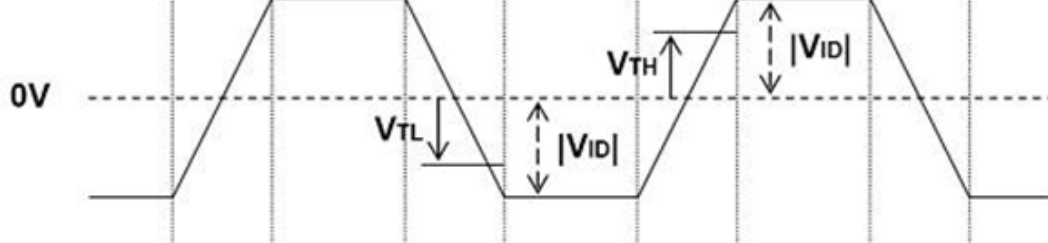

(2) AC Characteristics

Symbol	Description	Min	Max	Units	Conditions
F_{DEV}	Maximum deviation of input clock frequency during SSC	-	± 3	%	
F_{MOD}	Maximum modulation frequency of input clock during SSC	-	200	KHz	

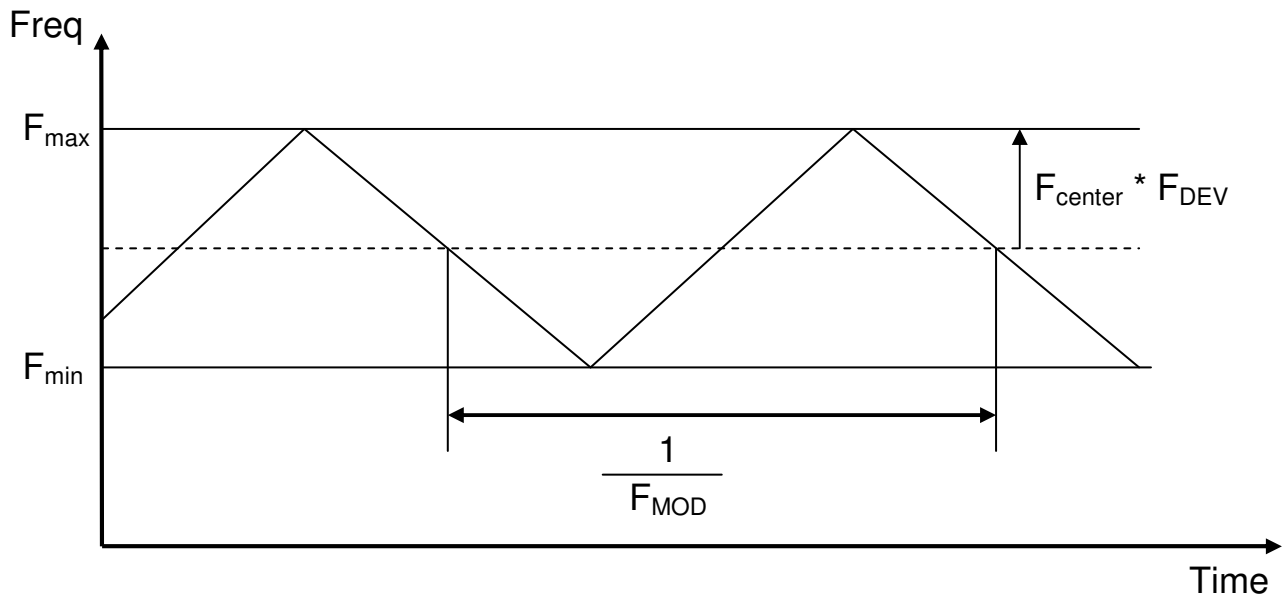

< Spread Spectrum >

5.2 Backlight Unit

Parameter guideline for LED driving is under stable conditions at 25 °C (Room Temperature):

Symbol	Description	Min.	Typ.	Max.	Unit	Note
IRLED	LED Operation Current	-	60	63	[mA]	Note 1
VLB	Light Bar Operation Voltage (for reference)	51	54.4	57.8	[Volt]	Note 2
PBLU	BLU Power Consumption (for reference)	-	13.1	14.6	[Watt]	Note 3
LTLED	LED Life Time (Typical)	30,000	-	-	[Hour]	Note 4

Each module consists of **68 pcs LED (4 strings x 17 pcs / string)**

Note 1: The specified current is 100% duty of LED chip input current, IRLED1,2,3,4 define as per strings LED current.

Note 2: The value showed is one string operation voltage.

Note 3: $PBLU = VLED * (IRLED1 + IRLED2 + IRLED3 + IRLED4)$

Note 4: Definition of life time: Brightness becomes to 50% of its original value. The minimum life time of LED unit is on the condition of IRLED = 60mA and 25±2 °C (Room Temperature).

6 Signal Characteristics

6.1 Pixel Format Definition

Following figure shows the relationship between the input signals and LCD pixel format.

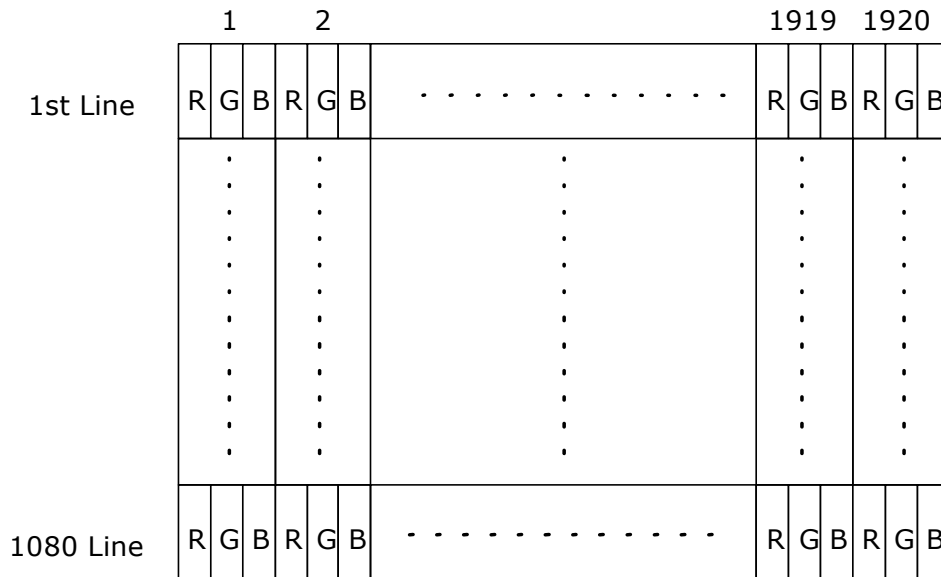

6.2 Input Data Format Definition

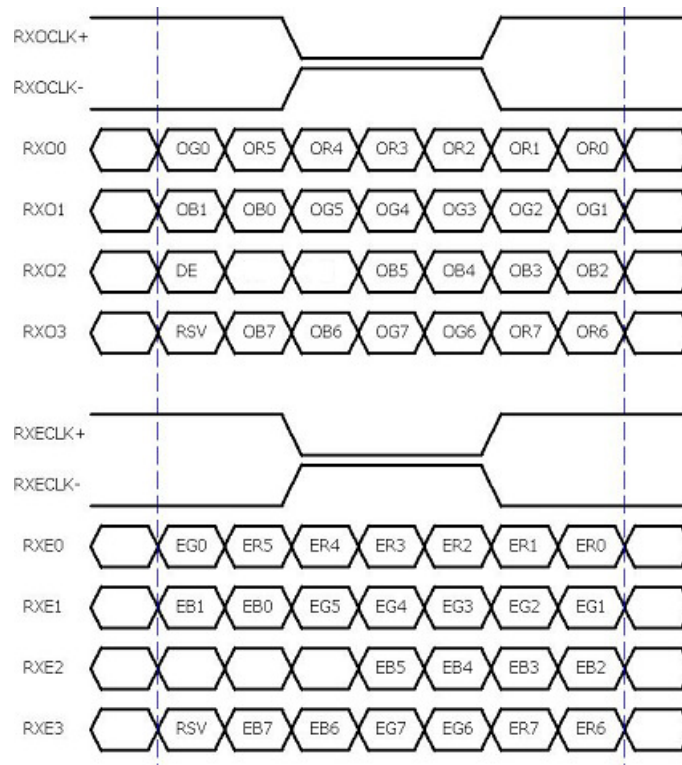

Note 1: R/G/B data 7:MSB, R/G/B data 0:LSB O = “Odd Pixel Data” E = “Even Pixel Data”

6.3 Signal Description

PIN #	SIGNAL NAME	DESCRIPTION
1	RxOIN0-	Negative LVDS differential data input (Odd data)
2	RxOIN0+	Positive LVDS differential data input (Odd data)
3	RxOIN1-	Negative LVDS differential data input (Odd data)
4	RxOIN1+	Positive LVDS differential data input (Odd data)
5	RxOIN2-	Negative LVDS differential data input (Odd data, DSPTMG)
6	RxOIN2+	Positive LVDS differential data input (Odd data, DSPTMG)
7	GND	Power Ground
8	RxOCLK-	Negative LVDS differential clock input (Odd clock)
9	RxOCLK+	Positive LVDS differential clock input (Odd clock)
10	RxOIN3-	Negative LVDS differential data input (Odd data)
11	RxOIN3+	Positive LVDS differential data input (Odd data)
12	RxEIN0-	Negative LVDS differential data input (Even data)
13	RxEIN0+	LVDS differential data input (Even data)
14	GND	Power Ground
15	RxEIN1-	Negative LVDS differential data input (Even data)
16	RxEIN1+	Positive LVDS differential data input (Even data)
17	GND	Power Ground
18	RxEIN2-	Negative LVDS differential data input (Even data)
19	RxEIN2+	Positive LVDS differential data input (Even data)
20	RxECLK-	Negative LVDS differential clock input (Even clock)
21	RxECLK+	Positive LVDS differential clock input (Even clock)
22	RxEIN3-	Negative LVDS differential data input (Even data)
23	RxEIN3+	Positive LVDS differential data input (Even data)
24	GND	Power Ground
25	Aging & HVS	NC (for AUO test only. Do not connect.)
26	SCL VCOM	NC (for AUO test only. Do not connect.)
27	SDA VCOM	NC (for AUO test only. Do not connect.)
28	VDD	Power +5V
29	VDD	Power +5V
30	VDD	Power +5V

Note 1: Input signals of odd and even clock shall be the same timing.

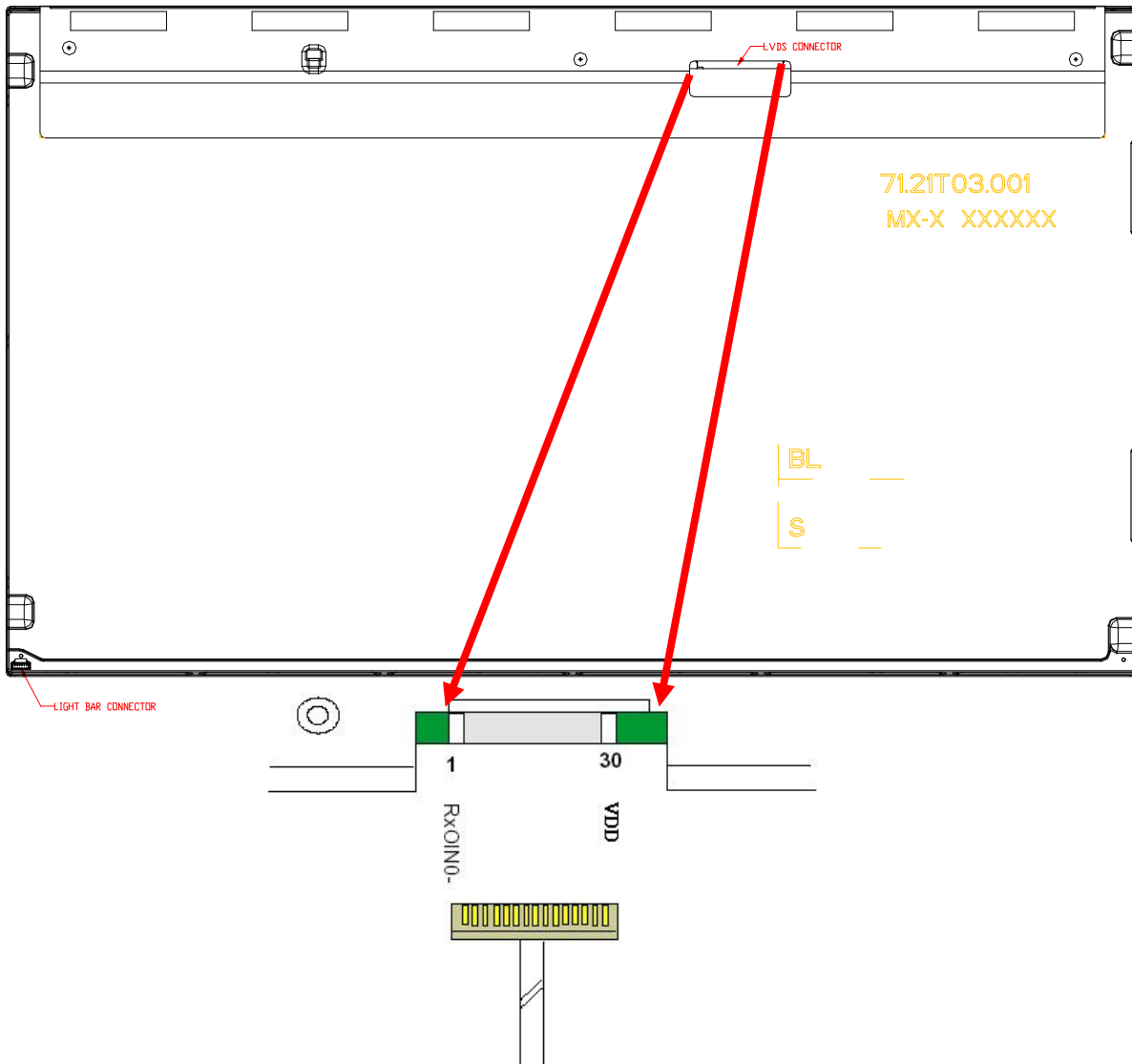

Timing Characteristics

The input signal timing specifications are shown as the following table

Signal	Item	Symbol	Min	Typ	Max	Unit
Vertical Section	Period	T_v	1088	1130	2047	Th
	Active	$T_{disp(v)}$	1080	1080	1080	Th
	Blanking	$T_{bp(v)}+T_{fp(v)}+PW_{vs}$	8	50	967	Th
Horizontal Section	Period	T_h	1004	1050	2047	Tclk
	Active	$T_{disp(h)}$	960	960	960	Tclk
	Blanking	$T_{bp(h)}+T_{fp(h)}+PW_{hs}$	44	90	1087	Tclk
Clock	Period	Tclk	25	13.89	11.11	ns
	Frequency	Freq	40	72	90	MHz
Frame rate	Frame rate	F	50	60	75	Hz

Note 1: DE mode only

6.4 Timing Diagram

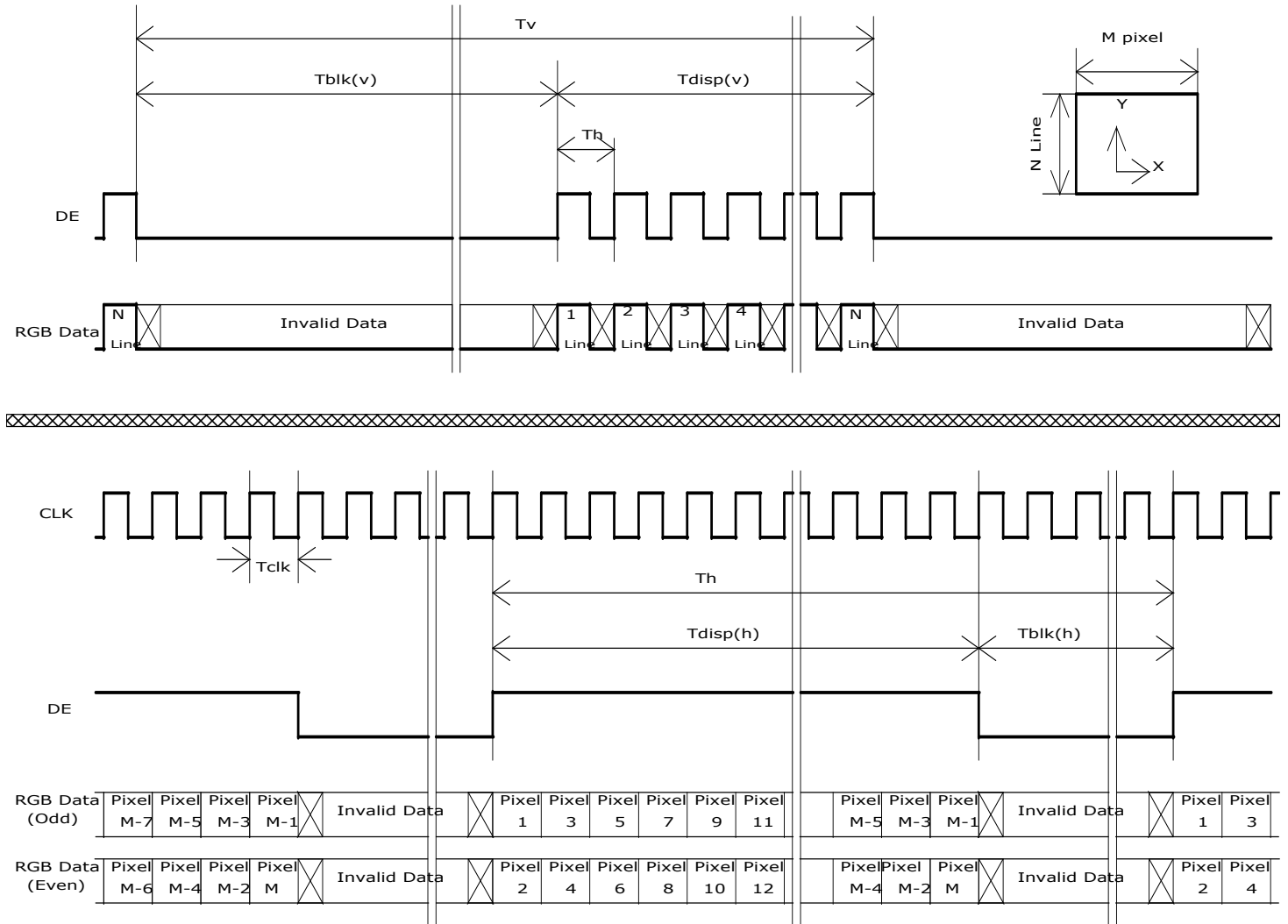

6.5 Power ON/OFF Sequence

VDD power and lamp on/off sequence are as follows. Interface signals are also shown in the chart. Signals from any system shall be Hi-Z state when VDD is off.

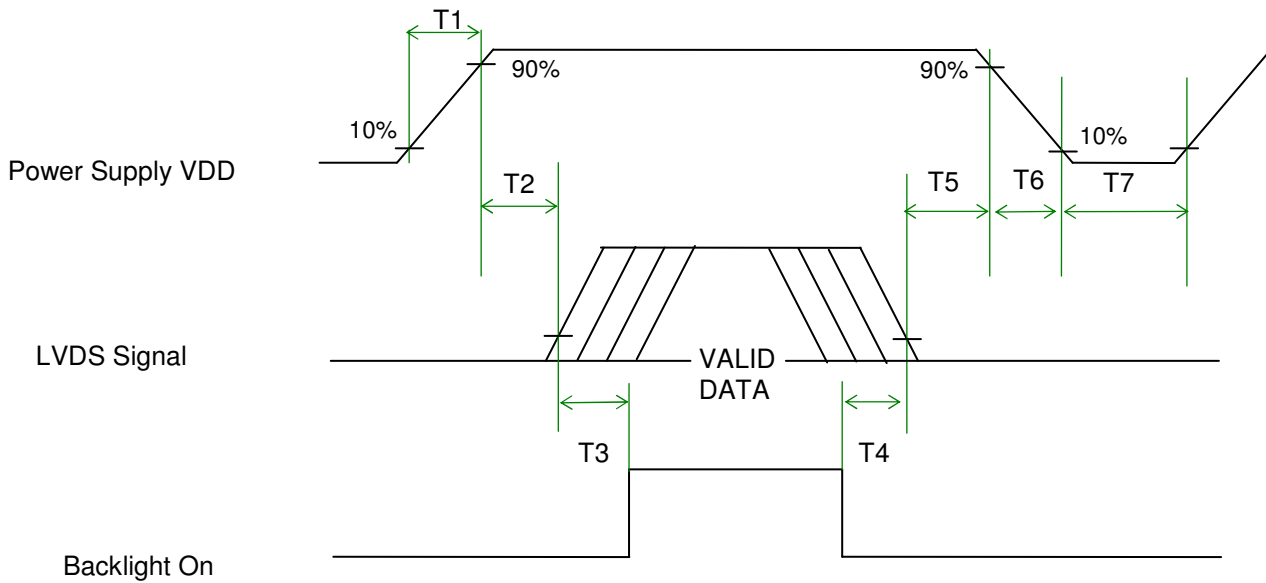

Power Sequence Timing

Parameter	Value			Unit
	Min.	Typ.	Max.	
T1	0.5	-	10	[ms]
T2	0	-	50	[ms]
T3	500	-	-	[ms]
T4	100	-	-	[ms]
T5	0	-	50	[ms] <i>Note1,2</i>
T6	5	-	100	[ms] <i>Note1,2</i>
T7	1000	-	-	[ms]

Note1 : Recommend setting T5 = 0ms to avoid electronic noise when VDD is off.

Note2 : During T5 and T6 period , please keep the level of input LVDS signals with Hi-Z state.

7 Connector and Pin Assignment

Physical interface is described as for the connector on module. These connectors are capable of accommodating the following signals and will be following components.

7.1 TFT LCD Module

Connector Name / Designation	Interface Connector / Interface Card
Manufacturer	SIN SHENG P-TWO
Type Part Number	MSCKT2407P30HB AL230F-A0G1D-P
Mating Housing Part Number	TBD

7.1.1 Pin Assignment

Pin#	Signal Name	Pin#	Signal Name
1	RxOIN0-	2	RxOIN0+
3	RxOIN1-	4	RxOIN1+
5	RxOIN2-	6	RxOIN2+
7	GND	8	RxOCLKIN-
9	RxOCLKIN+	10	RxOIN3-
11	RxOIN3+	12	RxEIN0-
13	RxEIN0+	14	GND
15	RxEIN1-	16	RxEIN1+
17	GND	18	RxEIN2-
19	RxEIN2+	20	RxECLKIN-
21	RxECLKIN+	22	RxEIN3-
23	RxEIN3+	24	GND
25	NC (for AUO test only. Do not connect)	26	NC (for AUO test only. Do not connect)
27	NC (for AUO test only. Do not connect)	28	VDD
29	VDD	30	VDD

7.2 LED Connector on Backlight Unit

This connector is mounted on LED light bar.

Connector Name / Designation	Light Bar Connector
Manufacturer	ENTRY(E&T)
Type Part Number	3707K-S06N-21R

7.2.1 LED Pin assignment

Pin#	Signal Name
1	IRLED1 (current out)
2	IRLED2 (current out)
3	VLED (voltage in)
4	VLED (voltage in)
5	IRLED3 (current out)
6	IRLED4 (current out)



7.2.2 LED Connector Dimension

$H \times V \times D = 13.9 \times 3.00 \times 4.25$, Pitch = 1.0 (unit = mm)

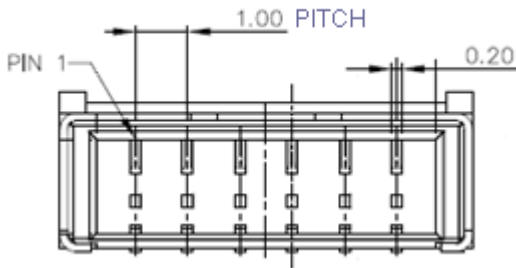
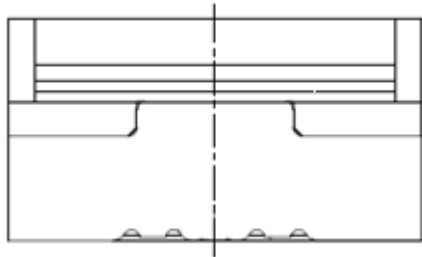

7.2.3 LED Mating housing dimension

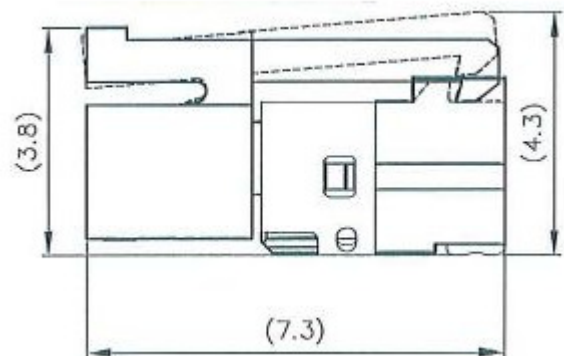
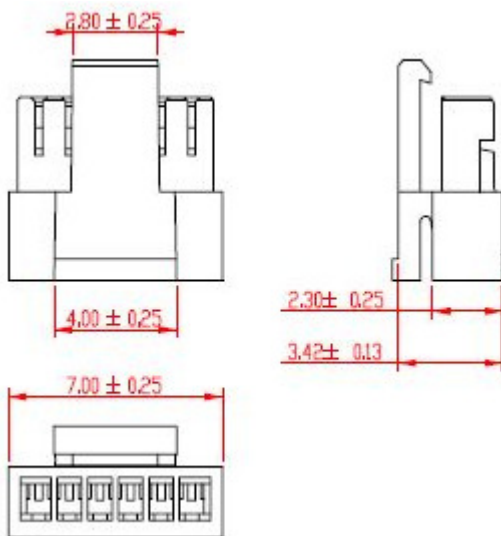

8 Reliability Test

Environment test conditions are listed as following table.

Items	Required Condition	Note
Temperature Humidity Bias (THB)	Ta= 50°C, 80%RH, 300 hours	
High Temperature Operation (HTO)	Ta= 50°C, 50%RH, 300 hours	
Low Temperature Operation (LTO)	Ta= 0°C, 300 hours	
High Temperature Storage (HTS)	Ta= 60°C, 300 hours	
Low Temperature Storage (LTS)	Ta= -20°C, 300 hours	
Vibration Test (Non-operation)	Acceleration: 1.5 Grms Wave: Random Frequency: 10 - 200 Hz Duration: 30 Minutes each Axis (X, Y, Z)	
Shock Test (Non-operation)	Acceleration: 50 G Wave: Half-sine Active Time: 20 ms Direction: ±X, ±Y, ±Z (one time for each Axis)	
Drop Test	Height: 46 cm, package test	
Thermal Shock Test (TST)	-20°C/30min, 60°C/30min, 100 cycles	Note 1
On/Off Test	On/10sec, Off/10sec, 30,000 cycles	
ESD (Electro Static Discharge)	Contact Discharge: ± 8KV, 150pF(330Ω) 1sec, 15 points, 25 times/ point	Note 2
	Air Discharge: ± 15KV, 150pF(330Ω) 1sec 15 points, 25 times/ point	
Altitude Test	Operation: 18,000 ft Non-Operation: 40,000 ft	

Note 1: The TFT-LCD module will not sustain damage after being subjected to 100 cycles of rapid temperature change. A cycle of rapid temperature change consists of varying the temperature from -20°C to 60°C, and back again. Power is not applied during the test. After temperature cycling, the unit is placed in normal room ambient for at least 4 hours before power on.

Note 2: EN61000-4-2, ESD class B: Certain performance degradation allowed:

- No data lost
- Self-recoverable
- No hardware failures

9 Shipping Label

The label on the panel is shown as below:

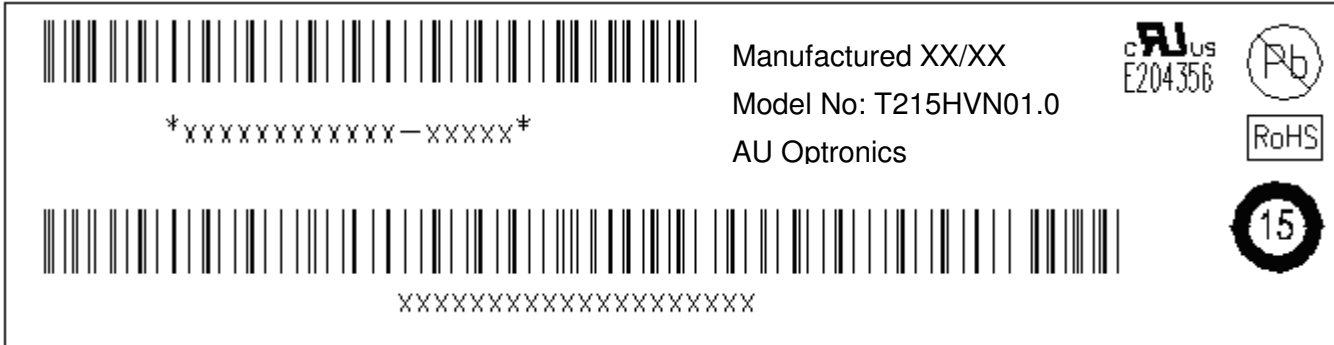

Note 1: For Pb Free products, AUO will add  for identification.

Note 2: For RoHS compatible products, AUO will add  for identification.

Note 3: For China RoHS compatible products, AUO will add  for identification.

Note 4: The Green Mark will be presented only when the green documents have been ready by AUO Internal Green Team.

10 Mechanical Characteristics

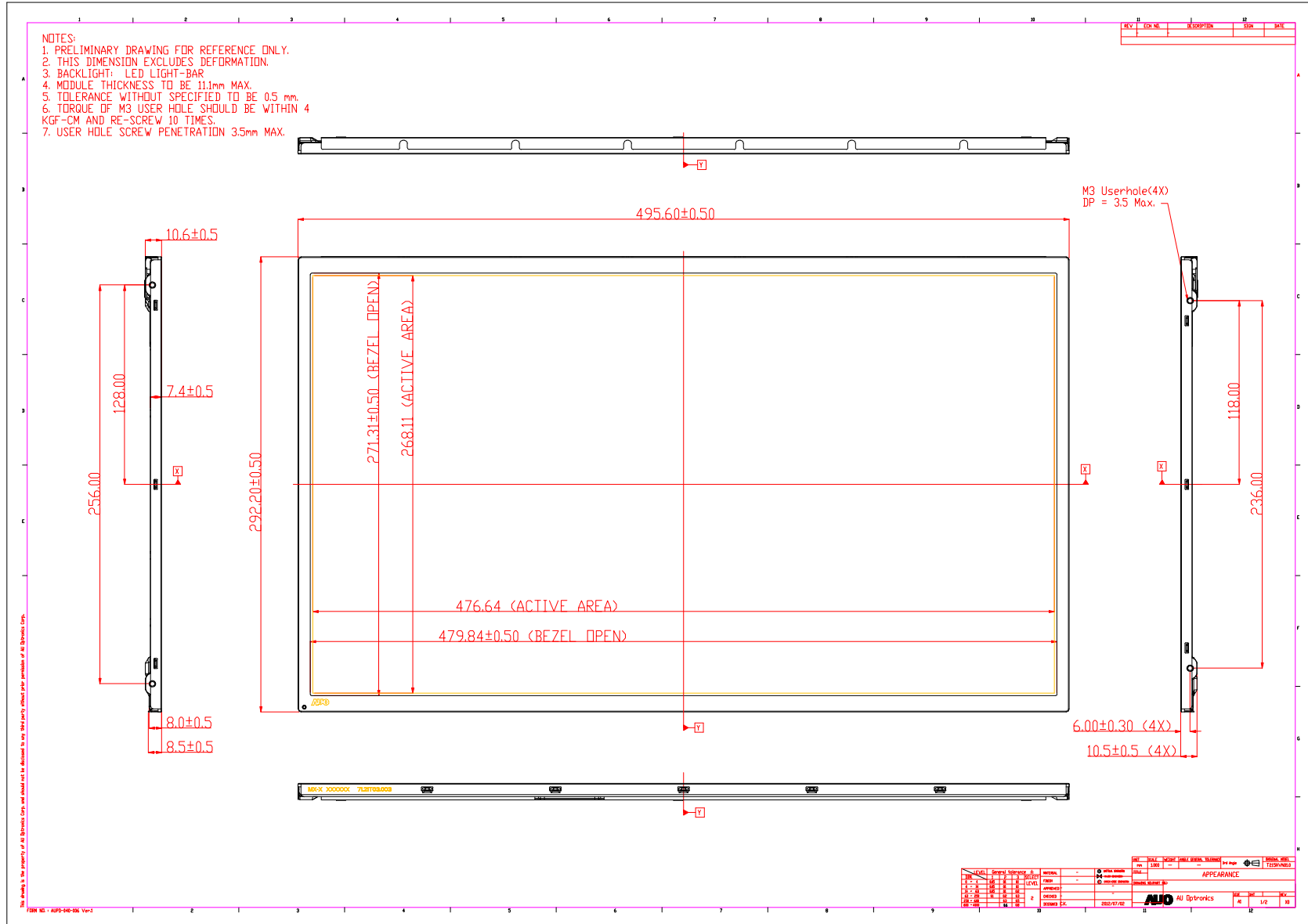

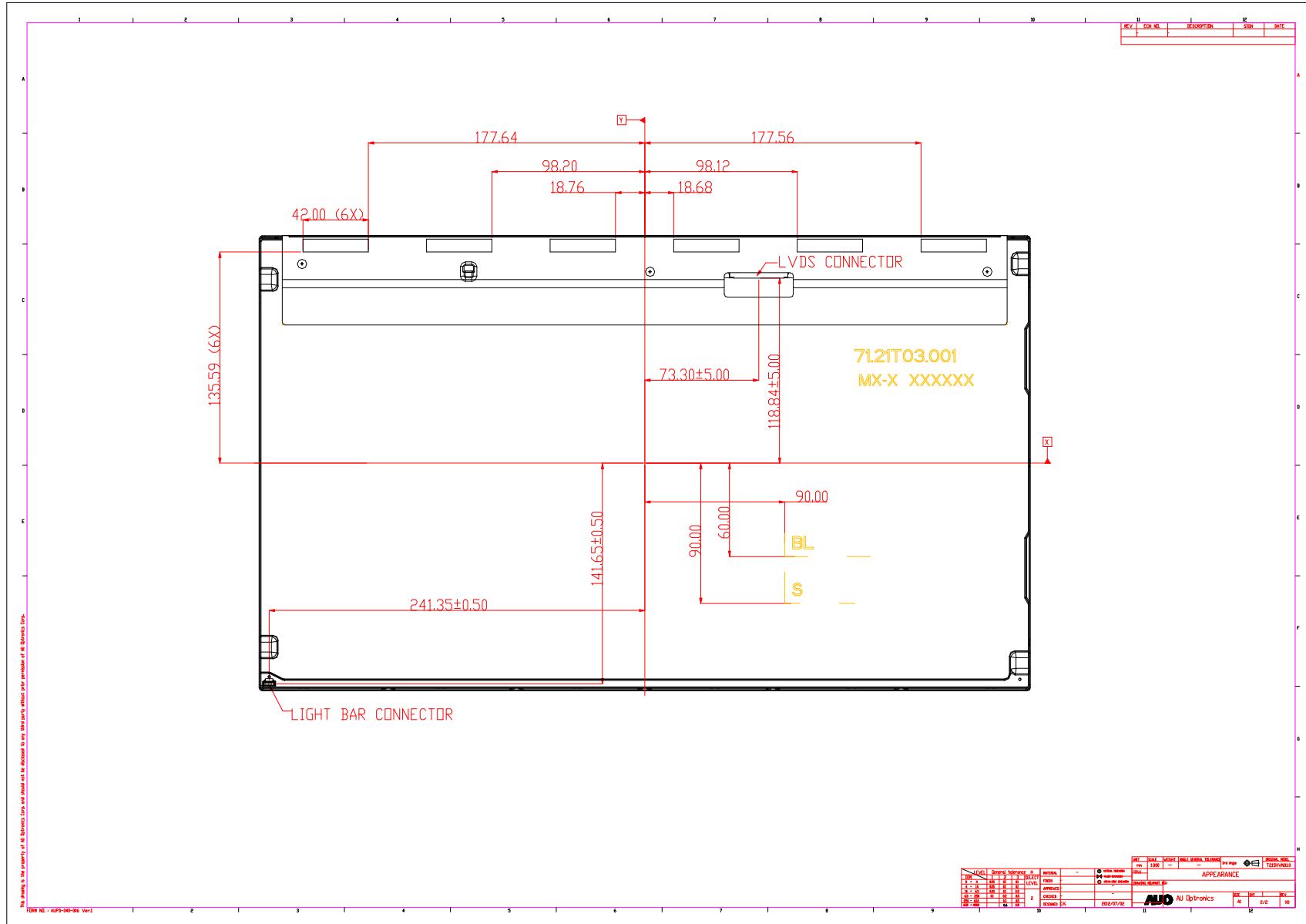

11 Packing Specification

11.1 Packing Flow

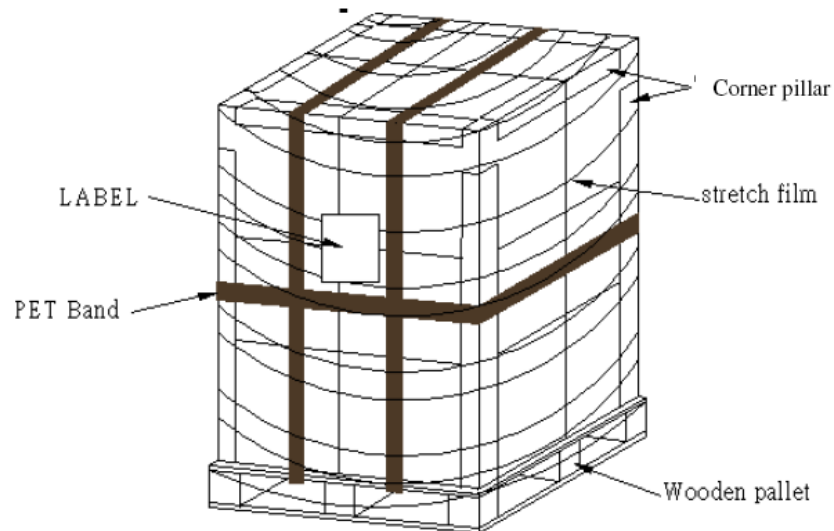
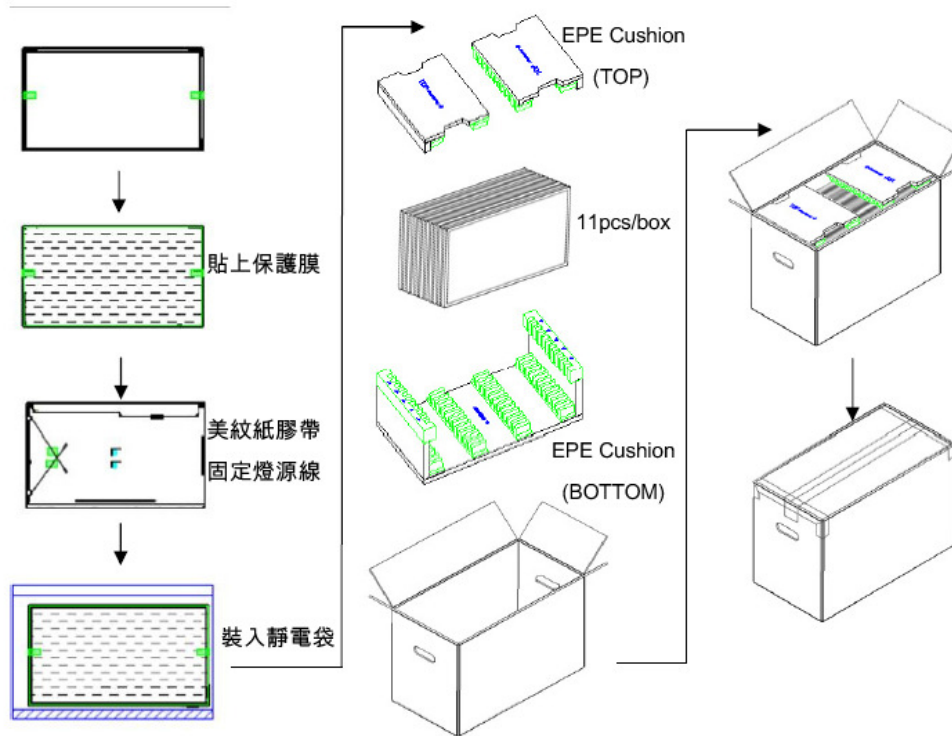

單層 pallet 打棧示意圖

11.2 Pallet and Shipment Information

	Item	Specification			Remark
		Q'ty	Dimension	Weight(kg)	
1	Panel	1	556(H)mm x 323.2(V)mm x 9.08(D)mm	1.9	Note 1
2	Cushion	1	--	0.38	
3	Box	1	556(L)mm x 292(W)mm x 375(H)mm	0.95	without Panel & cushion Note 1
4	Packing Box	11 pcs/Box	406(L)mm x 281(W)mm x 651(H)mm	22.1	with panel & cushion Note 1
5	Pallet	1	1150(L)mm x 910(W)mm x 132(H)mm	12	Note 1
6	Pallet after Packing	18boxes/pallet	1150(L)mm x 910(W)mm x 132(H)mm	390	Note 1

Note 1: Estimated value which is subject to change based on real measured data.