



Product Description: 26 inch TFT-LCD PANEL			
-----			
AUO Model Name: T260XW02 VG			
Customer Part No/Project Name:			
Customer Signature	Date	AUO	Date



*Document Version: 1.0*

*Date:2006/12/1*

## **Product Functional Specification**

**26" Color TFT-LCD Module  
Model Name: T260XW02 VG  
(QDI Model: QD26HL0101)**

**() Preliminary Specification  
(\* Final Specification)**



**This specification sheet is for model name change, since AUO merged QDI from 2006/10/1**

**This Specification Sheet keep the original QDI Model name and Spec.**

**New Model name and old model name comparison table as following:**

	<b>AUO</b>	<b>QDI</b>
<b>Model Name</b>	<b>T260XW02 VG</b>	<b>QD26HL0101</b>
<b>Change Item</b>	<b>1. Carton Printing format 2. Product Serial label format</b>	





## Content List

	<b>Page</b>
<b>1. Application</b>	<b>5</b>
<b>2. Overview</b>	<b>5</b>
<b>3. General Specifications</b>	<b>5</b>
<b>4. Input Terminals</b>	<b>6</b>
<b>5. Absolute Maximum Ratings</b>	<b>5</b>
<b>6. Electrical Characteristics</b>	<b>11</b>
<b>7. Timing Characteristics</b>	<b>15</b>
<b>8. Input Signals, Basic Display Colors and Gray Scale of Each Color</b>	<b>17</b>
<b>9. Optical Characteristics</b>	<b>18</b>
<b>10. Display Quality</b>	<b>21</b>
<b>11. Handling Precautions</b>	<b>21</b>
<b>12. Reliability Test Items</b>	<b>21</b>
<b>13. Others</b>	<b>22</b>
<b>14. Drawing</b>	<b>23</b>



## 1. Application

This specification applies to a color TFT-LCD module, QD26HL01

## 2. Overview

This module is a color active matrix LCD module incorporating amorphous silicon TFT (Thin Film Transistor). It is composed of a color TFT-LCD panel; driver ICs, control circuit and power supply circuit and a backlight unit.

Graphics and texts can be displayed on a 1366×3×768 dots panel with 16.7 million colors by using the LVDS (Low Voltage Differential Signaling) interface, 8-bit driving method and supplying +12V DC supply voltage for TFT-LCD panel driving.

The TFT-LCD panel used for this module has very high aperture ratio. A low-reflection and higher-color-saturation type color filter is also used for this panel. Therefore, high-brightness and high-contrast image, which is suitable for the LCD TV, HDTV and multimedia use, can be obtained by using this module.

### [Features]

- 1) High aperture panel; high-brightness
- 2) Brilliant and high contrast image.
- 3) High speed response
- 4) WXGA resolution. 16:9
- 5) LVDS interface.
- 6) QSV technology
- 7) Wide viewing angle.

## 3. General Specifications

Parameter	Specifications	Unit
Display size	66.05 (26") Diagonal	cm
Active area	575.769 (H)×323.712 (V)	mm
Pixel format	1366 (H)×768 (V)	Pixel
	(1 pixel = R+G+B dots)	
Pixel pitch	0.4215 (H) × 0.4215 (V)	mm
Pixel configuration	R,G,B vertical stripe	
Display mode	Normally Black	
Unit outline dimensions	626 x 373	mm
Thickness	Typ. 40.9	mm



<b>Weight</b>	<b>TBD</b>	<b>g</b>
<b>Surface treatment</b>	<b>Anti-glare(12%) and hard-coating 3H</b>	
<b>Lamp Quantity</b>	<b>8 U shape</b>	<b>pcs</b>

©Copyright AU Optronics, Inc.  
Sep, 2006 All Rights Reserved.  
No Reproduction and Redistribution Allowed



## 4. Input Terminals

### 4-1. TFT-LCD panel driving

**CN1 (LVDS signals and +12V DC power supply)**

**Connector on Panel : FI-X30SSL-HF(Manufactured by JAE) or**

**Equivalent**

**Mating connector : FI-30C2L (Manufactured by JAE) or Equivalent**

Pin No	Symbol	Description	Default
1	VCC	+12V, DC, Regulated	
2	VCC	+12V, DC, Regulated	
3	VCC	+12V, DC, Regulated	
4	VCC	+12V, DC, Regulated	
5	GND	Ground and Signal Return	
6	GND	Ground and Signal Return	
7	GND	Ground and Signal Return	
8	GND	Ground and Signal Return	
9	LVDS Option	High/Open for Normal (NS), Low for JEIDA	Default NS type
10	Reserved	N.C.	Test Mode?
11	GND	Ground and Signal Return for LVDS	
12	RXIN0-	LVDS Channel 0 negative	
13	RXIN0+	LVDS Channel 0 positive	
14	GND	Ground and Signal Return for LVDS	
15	RXIN1-	LVDS Channel 1 negative	
16	RXIN1+	LVDS Channel 1 positive	
17	GND	Ground and Signal Return for LVDS	
18	RXIN2-	LVDS Channel 2 negative	
19	RXIN2+	LVDS Channel 2 positive	
20	GND	Ground and Signal Return for LVDS	
21	RXCLKIN-	LVDS Clock negative	





22	RXCLKIN+	LVDS Clock Positive	
23	GND	Ground and Signal Return for LVDS	
24	RXIN3-	LVDS Channel 3 negative	
25	RXIN3+	LVDS Channel 3 positive	
26	GND	Ground and Signal Return for LVDS	
27	Reserved	N.C.	Test Mode?
28	Reserved	N.C.	Test Mode?
29	GND	Ground and Signal Return	
30	GND	Ground and Signal Return	

**【Note 1】 All GND(ground) pins should be connected together.**

**【Note 2】 All  $V_{DD}$  (power supply) pins should be connected together.**



## 4-2 Interface block diagram

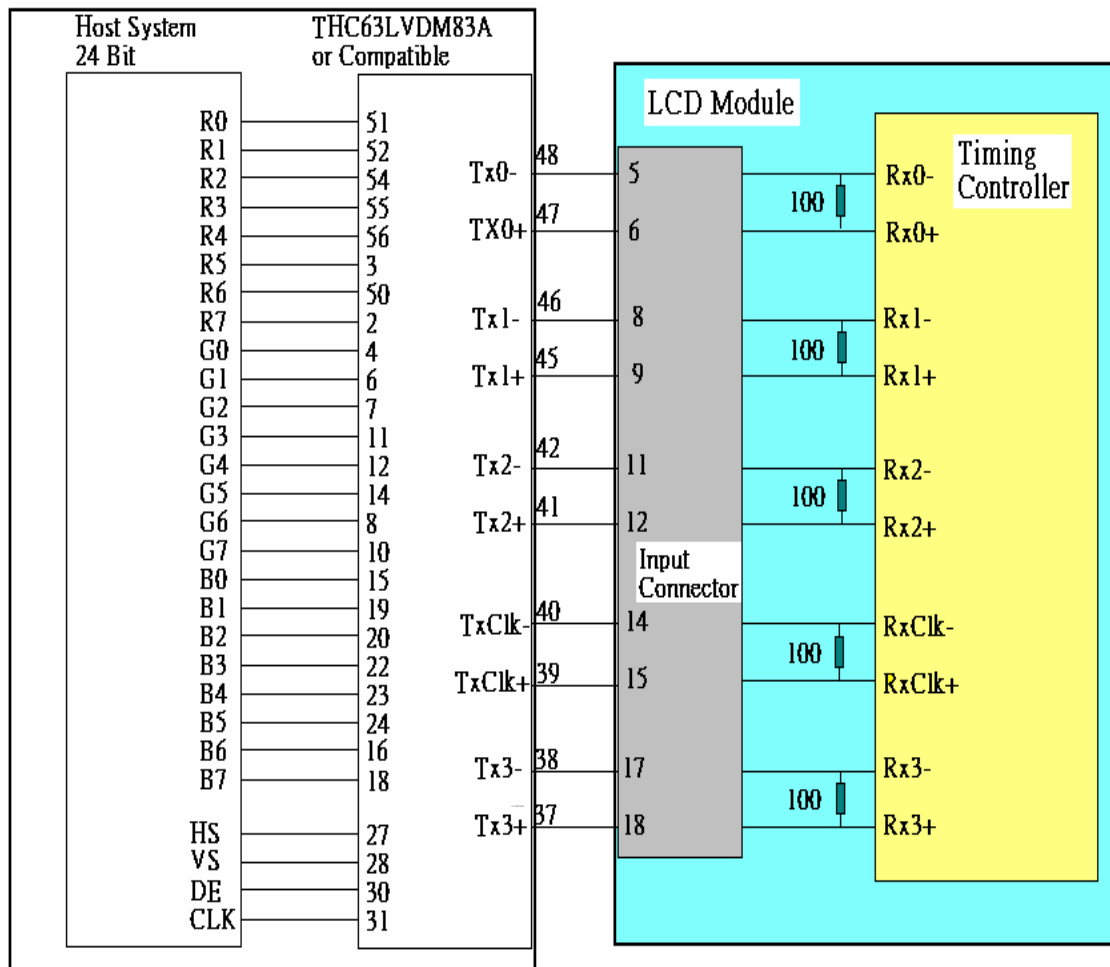

©Copyright AU Optronics, Inc.  
 Sep, 2006 All Rights Reserved.  
 No Reproduction and Redistribution Allowed



### 4-3. Backlight driving

#### 4-3-1. Inverter Connector

Connector on Inverter : S14B-PH-SM3(Manufactured by JST) or Equivalent

Mating connector : PHR-14 (Manufactured by JST) or Equivalent  
( ):need further discussion on both sides

Pin No	Symbol	Description	Default
1	VIN	Operating Voltage Supply, +24V DC regulated	24V
2	VIN	Operating Voltage Supply, +24V DC regulated	24V
3	VIN	Operating Voltage Supply, +24V DC regulated	24V
4	VIN	Operating Voltage Supply, +24V DC regulated	24V
5	VIN	Operating Voltage Supply, +24V DC regulated	24V
6	BLGND	Ground and Current Return	GND
7	BLGND	Ground and Current Return	GND
8	BLGND	Ground and Current Return	GND
9	BLGND	Ground and Current Return	GND
10	BLGND	Ground and Current Return	GND
11	ADIM	Analog Dimming : Open/High(3.3V) for Max. Lum.	Max
12	ON/OFF	BL On-Off : High(3.3V)or( Open) for BL On as default	On
13	PDIM	PWM Dimming Control : Open/High(3.3V) for Max. Lum	Max
14	PESEL	Selection of luminance control method, Vcx duty:high/, PWM duty:low/open	

#### 4-3-2. Lamp connector

*TBD*

## 5. Absolute Maximum Ratings

### LCD module

Parameter	Symbol	Condition	Ratings	Unit	Remark
+12V supply voltage	V <sub>DD</sub>	T <sub>a</sub> =25°C	-0.3 ~ +14.0	V	
Storage temperature	T <sub>stg</sub>	—	-20 ~ +60	°C	【Note1】

©Copyright AU Optronics, Inc.  
Sep, 2006 All Rights Reserved.  
No Reproduction and Redistribution Allowed



Operating temperature (Ambient)	Topa	—	0 ~ +50	℃
---------------------------------	------	---	---------	---

**【Note1】 Humidity : 90%RH Max. at  $T_a \leq 40^\circ\text{C}$ .**

**Maximum wet-bulb temperature at  $39^\circ\text{C}$  or less at  $T_a > 40^\circ\text{C}$ .**

**No condensation.**



## 6. Electrical Characteristics

### 6-1. TFT-LCD panel driving

Ta = 25°C

Parameter		Symbol	Min.	Typ.	Max.	Unit	Remark
V <sub>DD</sub>	Supply voltage	V <sub>DD</sub>	11.4	+12.0	12.6	V	【Note2】
	Current dissipation	I <sub>DD</sub>	—	340	700	m A	【Note3】
Permissive input ripple voltage		V <sub>RP</sub>	—	—	120	mV p-p	V <sub>DD</sub> =+12V
Differential input threshold voltage	High	V <sub>TH</sub>	—	—	100	mV	V <sub>CM</sub> =+1.2V 【Note1】
	Low	V <sub>TL</sub>	-100	—	—	mV	
Rush current		I <sub>RUSH</sub>			3.0	A	Rise time 470uS

【Note1】 V<sub>CM</sub> : Common mode voltage of LVDS driver.

【Note2】

Power On-off sequence

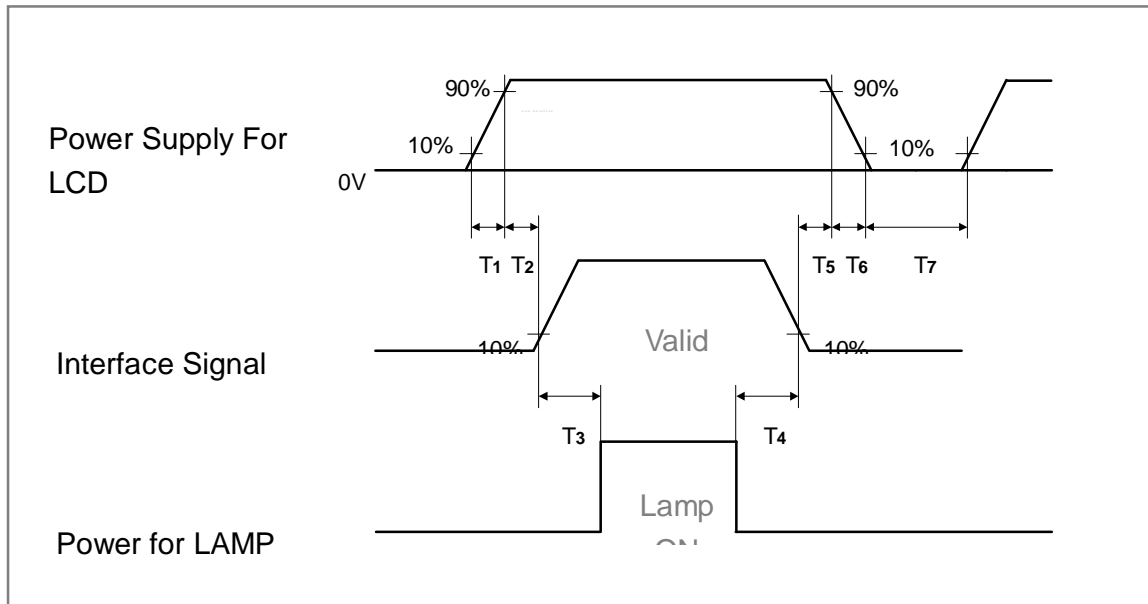

1ms < T1, T6 ≤ 10 ms      0.5ms < T2, T5 ≤ 50 ms      200ms < T3, T4      T7 > 1 s

【Note3】 Maximum current condition; Change to 1x1 dot checker board pattern. V<sub>DD</sub>=+12V



R	G	B	R	G	B
R	G	B	R	G	B
R	G	B	R	G	B
R	G	B	R	G	B

□ : 0 GS

■ : 255 GS

©Copyright AU Optronics, Inc.  
Sep, 2006 All Rights Reserved.  
No Reproduction and Redistribution Allowed



## 6-2. Backlight driving

The backlight system is a direct-lighting type with 8 U shape CCFT (Cold Cathode Fluorescent Tube).

The characteristics of the lamp are shown in the following table.

Parameter	Symbol	Min.	Typ.	Max.	Unit	Remark
Lamp current range	$I_L$	5.5	6	6.5	mArms	【Note1】
Lamp voltage	$V_L$		1000		Vrms	
Lamp power consumption	$P_L$		6		W	【Note2】 $I_L = \text{mA}$
Lamp frequency	$F_L$	42	45	48	kHz	【Note3】
Established starting voltage	$V_s$		1100	1500	Vrms	$T_a = 25^\circ\text{C}$
			1200	1500	Vrms	$T_a = 0^\circ\text{C}$ 【Note4】
Lamp life time	$L_L$	50000			hour	【Note5】

【Note1】 Lamp current is measured with current meter for high frequency as shown below.

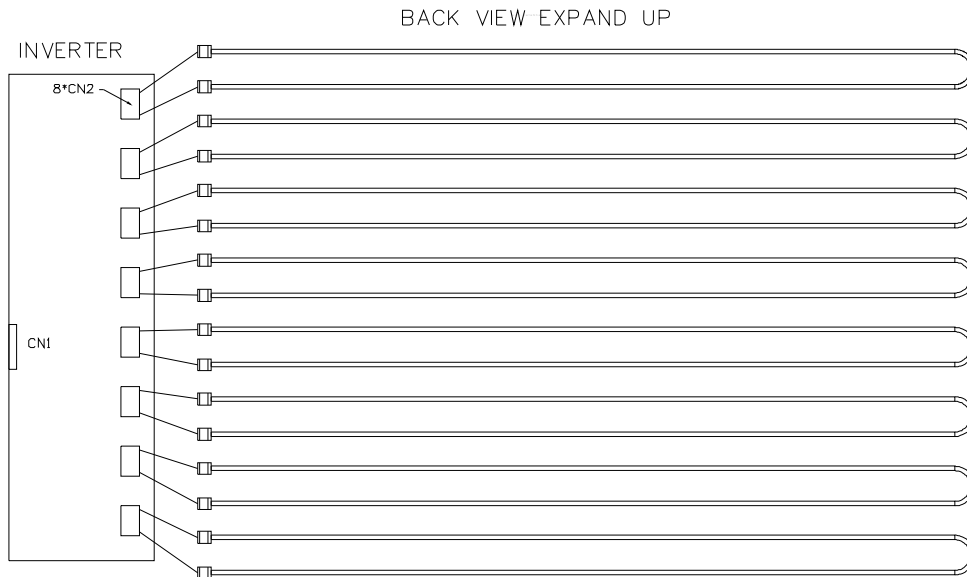

【Note2】 Calculated Value for reference ( $I_L \times V_L$ )

【Note3】 Lamp frequency may produce interference with horizontal synchronous frequency, and this may cause beat on the display.

Therefore lamp frequency shall be detached as much as possible from



the horizontal synchronous frequency and from the harmonics of horizontal synchronous to avoid interference.

**【Note4】** The voltage above this value should be applied to the lamp for more than 1 second to start-up. Otherwise the lamp may not be turned on.

**【Note5】** Lamp life time is defined as the time when either ① or ② occurs in the continuous operation under the condition of  $T_a = 25^{\circ}\text{C}$  and  $I_L = 6\text{mA}_{\text{rms}}$ .

① Brightness becomes 50 % of the original value under standard condition.

② Kick-off voltage at  $T_a = 0^{\circ}\text{C}$  exceeds maximum value.





**【Note6】** The performance of the backlight, for example life time or brightness, is much influenced by the characteristics of the DC-AC inverter for the lamp. When you design or order the inverter, please make sure that a poor lighting caused by the mismatch of the backlight and the inverter (miss-lighting, flicker, etc.) never occur. When you confirm it, the module should be operated in the same condition as it is installed in your instrument.

**【Note7】** The lamp wire length is TBD mm(from AL back cover surface to connector, not including connector length)

### 6-3 Backlight inverter

#### 6-3-1. Inverter Electrical Characteristics

Parameter	Symbol	Min.	Typ.	Max.	Unit	Notes
Power Supply Input Voltage	V <sub>DDB</sub>	22.8	24	25.2	Vdc	
Power Supply Input Current	I <sub>DDB</sub>	3300	3600	3900	mA	
Power Consumption	P <sub>B</sub>		86.4		W	

#### 6.4 Luminance Controls

Method	Adjustment and Luminance Ratio	PESEL	PDIM	Remark		
Voltage control	Adjustment – Continuous adjustment of Luminance by adjusting the voltage of BRTI within the rated range.	High/Open for max.	N/A			
					BRTI voltage	Luminance ratio
					0V	20%(minimum)
					3.3V	100% (maximum)
PWM control	Adjustment- The luminance is controlled by duty ratio of BRTP	LOW	PWM singal	See PWM		



	signal when PWSEL is low and PWM signal is inputted into BRTP terminal.			timing
	Duty Ratio	Luminance Ratio		
	0.2	20%(minimum)		
	1.0	100% (maximum)		

## 6-5. PWM timing

### 6-5-1. Timing diagram

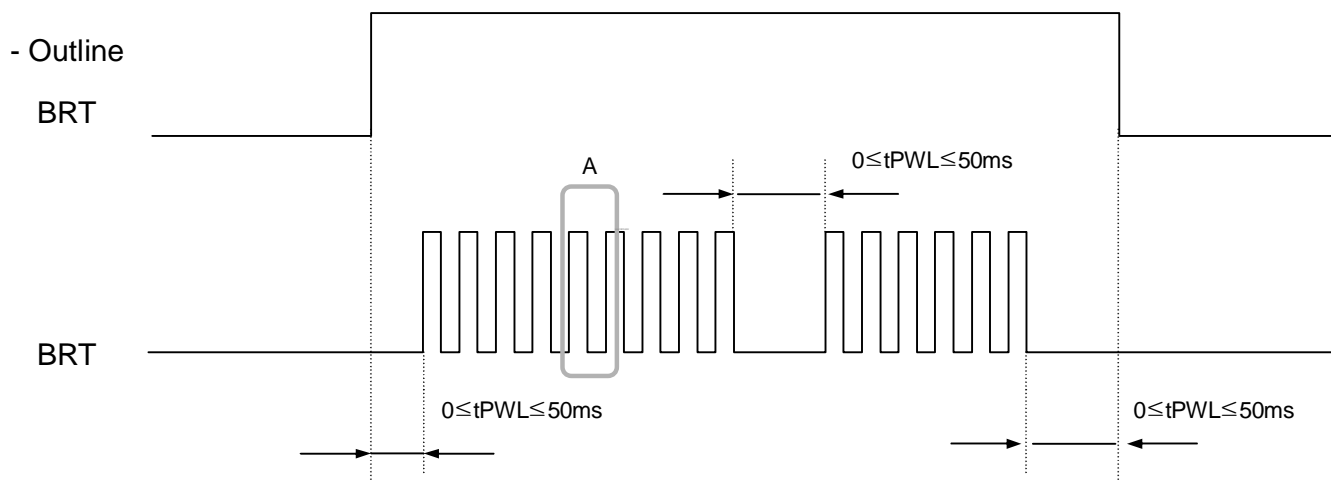

#### - Detail of A part

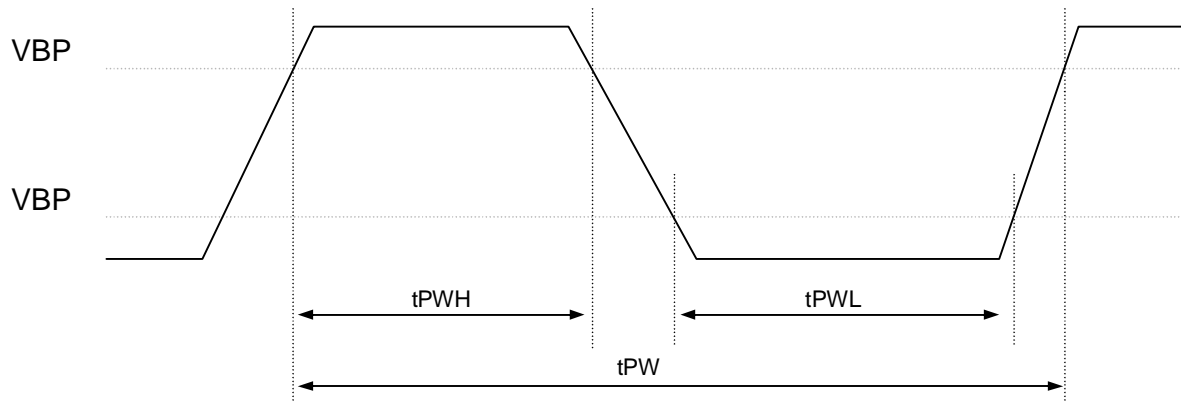

©Copyright AU Optonics, Inc.  
 Sep, 2006 All Rights Reserved.  
 No Reproduction and Redistribution Allowed



### 6-5-2. Each parameter

Parameter	Symbol	Min.	Typ.	Max.	Unit	Notes
Luminance control	FL	230	255	280	Hz	1, 2
Duty Ratio	DL	0.2	-	1.0	-	1, 3
Non signal Period	tPWL	0	-	50	Ms	4

Notes : 1. Definition of parameters is as follows

$$FL = \frac{1}{tPW} \quad , \quad DL = \frac{tPWH}{tPW}$$

2. See the following formula for luminance control frequency.

$$\text{Luminance control frequency} = tvv \times (n+0.25) [\text{or}(n+0.72)]$$

n=1,2,3,.....

tvv : See "7.1 Signal timing specification"

The interference noise of luminance control frequency and input signal frequency for  
LCD



## 7. Timing characteristics of LCD module input signals

### 7-1. Timing characteristics

(This is specified at digital outputs of LVDS driver.)

ITIME	Symbol		Min	Typ	Max	Unit	Notes
DCLK	Frequency	$F_{CLK}$	-	80	82	MHz	
	Period	$t_{CLK}$	12.2	12.5	-	ns	
Hsync	Period	$t_{HA}$	1512	1648	1780	$t_{CLK}$	
	Width-Active	$t_{HC}$	8	16	-		
	Frequency	$f_H$	44	48.54	52	kHz	
Vsync	Frequency	$f_V$	47	60	63	Hz	
	Period	$t_{VA}$	774	810	-	$t_{HA}$	
	Width-Active	$t_{VC}$	2	6	-		
Data Enable	Horizontal back porch	$t_{HD}$	8	80	-	$t_{CLK}$	
	Horizontal front porch	$t_{HF}$	16	186	-	$t_{CLK}$	
	Horizontal active	$t_{HE}$	1366	1366	1366	$t_{CLK}$	
	Horizontal blanking	$t_{HB}$	146	282		$t_{CLK}$	
	Vertical back porch	$t_{VD}$	2	20	-	$t_{HA}$	
	Vertical front porch	$t_{VF}$	2	16	-	$t_{HA}$	
	Vertical active	$t_{VE}$	768	768	768	$t_{HA}$	
	Vertical blanking	$t_{VB}$	6	42		$t_{HA}$	

Notes : 1.The performance of electro-optical characteristics may be influenced by variance of the vertical refresh rate.

2. Hsync period will be a double number of character (8).

7-2 Signal Timing Waveform(The time “B” is  $t_{HB}$  on horizontal timing and  $t_{VB}$  on vertical timing)

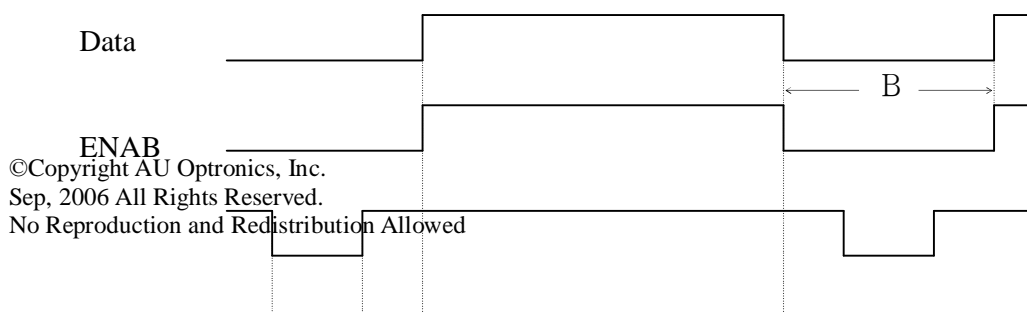

©Copyright AU Optronics, Inc.  
 Sep, 2006 All Rights Reserved.  
 No Reproduction and Redistribution Allowed



Sync

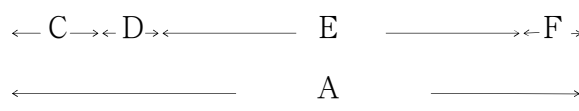

©Copyright AU Optronics, Inc.  
Sep, 2006 All Rights Reserved.  
No Reproduction and Redistribution Allowed



### 8. Input Signals, Basic Display Colors and Gray Scale of Each Color

	Colors & Gray scale	Data Signal																							
		R0	R1	R2	R3	R4	R5	R6	R7	G0	G1	G2	G3	G4	G5	G6	G7	B0	B1	B2	B3	B4	B5	B6	B7
Basic Color	Black	0	0	0	0	0	0	0	0	0	0	0	0	0	0	0	0	0	0	0	0	0	0	0	0
	Blue	0	0	0	0	0	0	0	0	0	0	0	0	0	0	0	0	1	1	1	1	1	1	1	1
	Green	0	0	0	0	0	0	0	0	1	1	1	1	1	1	1	1	0	0	0	0	0	0	0	0
	Cyan	0	0	0	0	0	0	0	0	1	1	1	1	1	1	1	1	1	1	1	1	1	1	1	1
	Red	1	1	1	1	1	1	1	1	0	0	0	0	0	0	0	0	0	0	0	0	0	0	0	0
	Magenta	1	1	1	1	1	1	1	1	0	0	0	0	0	0	0	0	1	1	1	1	1	1	1	1
	Yellow	1	1	1	1	1	1	1	1	1	1	1	1	1	1	1	1	0	0	0	0	0	0	0	0
	White	1	1	1	1	1	1	1	1	1	1	1	1	1	1	1	1	1	1	1	1	1	1	1	1
Gray Scale of Red	Black	0	0	0	0	0	0	0	0	0	0	0	0	0	0	0	0	0	0	0	0	0	0	0	0
	ñ	1	0	0	0	0	0	0	0	0	0	0	0	0	0	0	0	0	0	0	0	0	0	0	0
	Darker	0	1	0	0	0	0	0	0	0	0	0	0	0	0	0	0	0	0	0	0	0	0	0	0
	ñ				á								á								á				
	ò				â								â								â				
	Bright	1	0	1	1	1	1	1	1	0	0	0	0	0	0	0	0	0	0	0	0	0	0	0	0
	ò	0	1	1	1	1	1	1	1	0	0	0	0	0	0	0	0	0	0	0	0	0	0	0	0
Red	1	1	1	1	1	1	1	1	0	0	0	0	0	0	0	0	0	0	0	0	0	0	0	0	
Gray Scale of Green	Black	0	0	0	0	0	0	0	0	0	0	0	0	0	0	0	0	0	0	0	0	0	0	0	0
	ñ	0	0	0	0	0	0	0	0	1	0	0	0	0	0	0	0	0	0	0	0	0	0	0	0
	Darker	0	0	0	0	0	0	0	0	0	1	0	0	0	0	0	0	0	0	0	0	0	0	0	0
	ñ				á								á								á				
	ò				â								â								â				
	Bright	0	0	0	0	0	0	0	0	1	0	1	1	1	1	1	1	0	0	0	0	0	0	0	0
	ò	0	0	0	0	0	0	0	0	0	1	1	1	1	1	1	1	0	0	0	0	0	0	0	0
Green	0	0	0	0	0	0	0	0	1	1	1	1	1	1	1	1	0	0	0	0	0	0	0	0	
Gray Scale of Blue	Black	0	0	0	0	0	0	0	0	0	0	0	0	0	0	0	0	0	0	0	0	0	0	0	0
	ñ	0	0	0	0	0	0	0	0	0	0	0	0	0	0	0	0	1	0	0	0	0	0	0	0
	Darker	0	0	0	0	0	0	0	0	0	0	0	0	0	0	0	0	0	1	0	0	0	0	0	0
	ñ				á								á								á				
ò				â								â								â					

©Copyright AU Optronics, Inc.  
 Sep, 2006 All Rights Reserved.  
 No Reproduction and Redistribution Allowed



	Bright	0 0 0 0 0 0 0 0 0	0 0 0 0 0 0 0 0 0	1 0 1 1 1 1 1 1 1
	ò	0 0 0 0 0 0 0 0 0	0 0 0 0 0 0 0 0 0	0 1 1 1 1 1 1 1 1
	Blue	0 0 0 0 0 0 0 0 0	0 0 0 0 0 0 0 0 0	1 1 1 1 1 1 1 1 1

0 : Low level voltage, 1 : High level voltage



## 9. Optical Characteristics

Ta=25°C, V<sub>DD</sub>=+12V

Parameter		Symbol	Condition	Min.	Typ.	Max.	Unit	Remark
Viewing angle range	L/R	$\theta_{21}, \theta_{22}$	CR>10		85		Deg.	【Note1,4】
	U	$\theta_{11}$			85		Deg.	
	D	$\theta_{12}$			85		Deg.	
Contrast ratio		C R n	$\theta = 0^\circ$		600	—		【Note2,4】
Response time		$\tau$		—	25	—	ms	【Note3,4】
Rise time	$\tau_r$				TBD	—	ms	
Fall time	$\tau_d$				TBD	—	ms	
Chromaticity of White (CIE 1931)		W <sub>x</sub>		0.245	0.275	0.305		【Note4】 Color temperature 10000K NTSC 72%
		W <sub>y</sub>		0.268	0.298	0.328		
Chromaticity of Red (CIE 1931)		R <sub>x</sub>			TBD			
		R <sub>y</sub>			TBD			
Chromaticity of Green (CIE 1931)		G <sub>x</sub>			TBD			
		G <sub>y</sub>			TBD			
Chromaticity of Blue (CIE 1931)		B <sub>x</sub>			TBD			
		B <sub>y</sub>			TBD			
Luminance of white 【Note4】		Y <sub>L</sub>		400	500		Cd/m <sup>2</sup>	
White Uniformity		$\delta_w$		—	-	1.3		【Note5】
Black Uniformity		$\delta_B$				1.3		【Note5】

※ The measurement shall be executed 30 minutes after lighting at rating. (typical condition : I<sub>L</sub> = 6mArms)

The optical characteristics shall be measured in a dark room or equivalent state with the method shown in Fig.1 below.

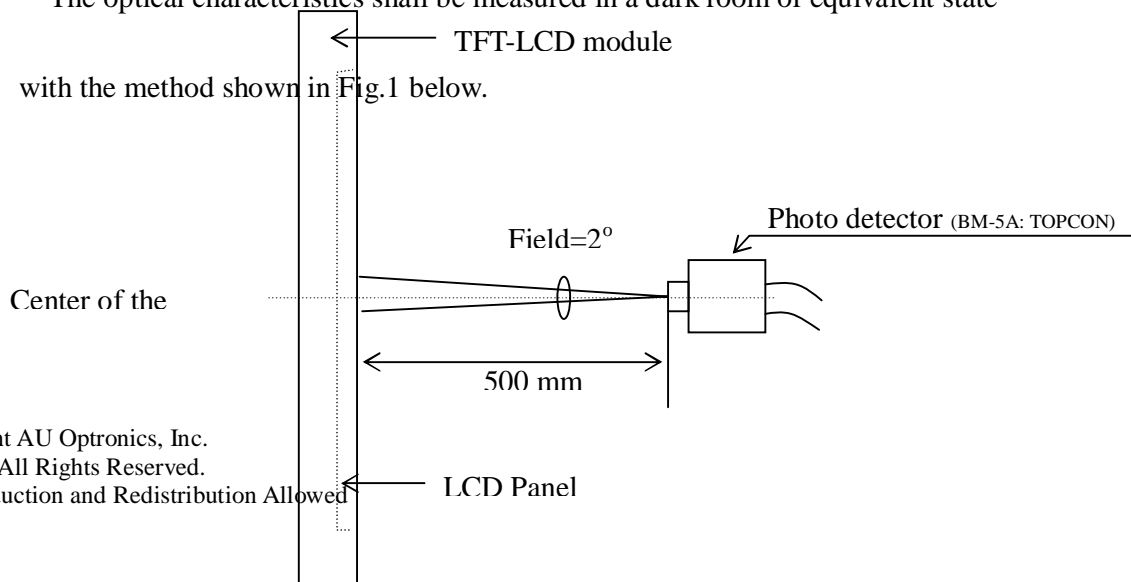

©Copyright AU Optonics, Inc.  
Sep, 2006 All Rights Reserved.  
No Reproduction and Redistribution Allowed





©Copyright AU Optronics, Inc.  
Sep, 2006 All Rights Reserved.  
No Reproduction and Redistribution Allowed



**【Note1】 Definitions of viewing angle range:**

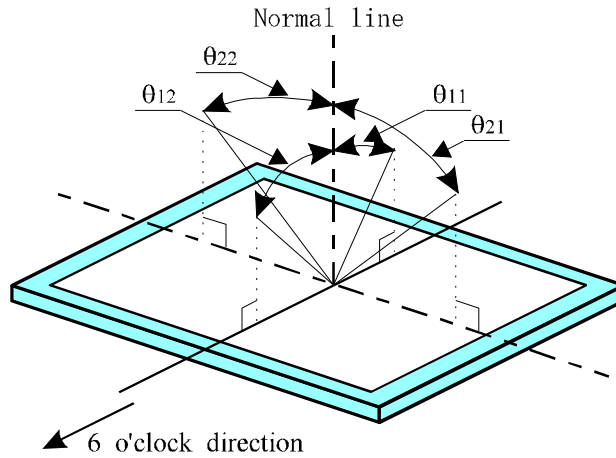

**【Note2】 Definition of contrast ratio:**

The contrast ratio is defined as the following.

$$\text{Contrast Ratio (CR)} = \frac{\text{Luminance (brightness) with all pixels}}{\text{Luminance (brightness) with all pixels}}$$

**【Note3】 Definition of response time:**

The response time is defined as the following figure and shall be measured by

switching the input signal for "black" and "white" .

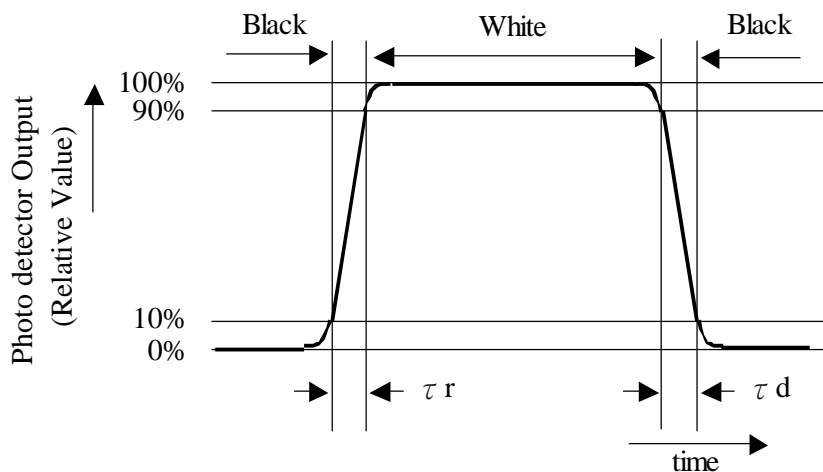

**【Note4】 This shall be measured at center of the screen.**

©Copyright AU Optronics, Inc.  
 Sep, 2006 All Rights Reserved.  
 No Reproduction and Redistribution Allowed

**[Note5] Definition of white uniformity:**

**White and black uniformity is defined as the following with nine measurements**

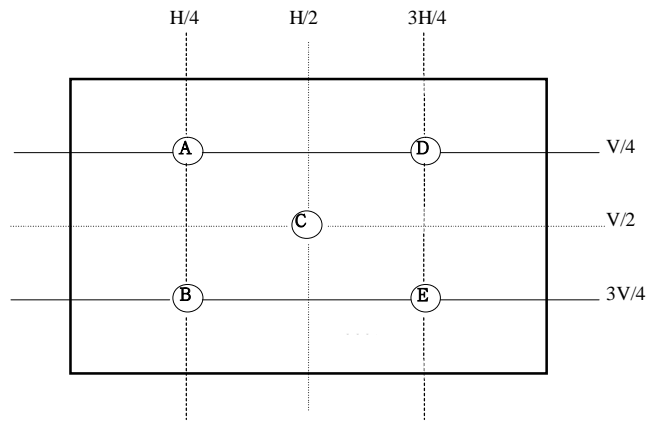

**Maximum Luminance (of 5 points measurement)**

**$\delta_{wR}$  – Minnum Luminance (of 5 points measurement)**



## 10. Display Quality

The display quality of the color TFT-LCD module shall be in compliance with the Incoming Inspection Standard.

## 11 · Handling Precautions

- a) Be sure to turn off the power supply when inserting or disconnecting the cable.
- b) Be sure to design the cabinet so that the module can be installed without any extra stress such as warp or twist.
- c) Since the front polarizer is easily damaged, pay attention not to scratch it.
- d) Wipe off water drop immediately. Long contact with water may cause discoloration or spots.
- e) When the panel surface is soiled, wipe it with absorbent cotton or other soft cloth.
- f) Since the panel is made of glass, it may break or crack if dropped or bumped on hard surface. Handle with care.
- g) Since CMOS LSI is used in this module, take care of static electricity and injure the human earth when handling.
- h) Observe all other precautionary requirements in handling components.
- i) This module has its circuitry PCBs on the rear side and should be handled carefully in order not to be stressed. —
- j) Laminated film is attached to the module surface to prevent it from being scratched . Peel the film off slowly just before the use with strict attention to electrostatic charges. Ionized air shall be blown over during the action. Blow off the 'dust' on the polarizer by using an ionized nitrogen gun, etc..

## 12. Reliability test items

No.	Test item	Conditions
1	High temperature storage test	Ta = 60°C    240h
2	Low temperature storage test	Ta = -20°C    240h
3	High temperature & high humidity operation test	Ta = 50°C ; 80 %RH    240h
4	High temperature operation test	Ta = 60°C    240h
5	Low temperature operation test	Ta = 0°C    240h

©Copyright AU Optronics, Inc.  
 Sep, 2006 All Rights Reserved.  
 No Reproduction and Redistribution Allowed



6	<b>Vibration test (non-operating)</b>	<b>Frequency: 10~500Hz, 1.0G , 20 min/each axis</b>
7	<b>Shock test (non- operating)</b>	<b>Gravity : 100G Pulse width : 2ms, half sine wave Direction : <math>\pm X, \pm Y, \pm Z</math> Once for each direction.</b>



## 13 · Others

### 1) LCD Module Label:

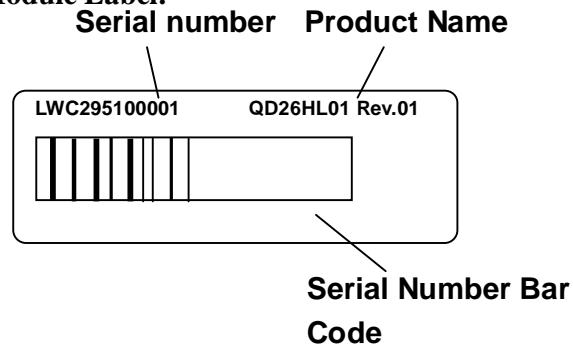

**LWC295100001** Digital code 4, 5 is Date code.

Digital 4 (Year) 1: 2001, 2: 2002, 3:2003,....

Digital 5 (Month) 1: Jan, 2: Feb,... , A:Oct, B:Nov., C: Dec.

2) Adjusting volume has been set optimally before shipment, so do not change any adjusted value.

If adjusted value is changed, the specification may not be satisfied.

**3) Disassembling the module can cause permanent damage and should be strictly avoided.**

4) Please be careful since image retention may occur when a fixed pattern is displayed for a long time.

**5) If any problem occurs in relation to the description of this specification, it shall be resolved through discussion with spirit of cooperation.**



14. Drawing

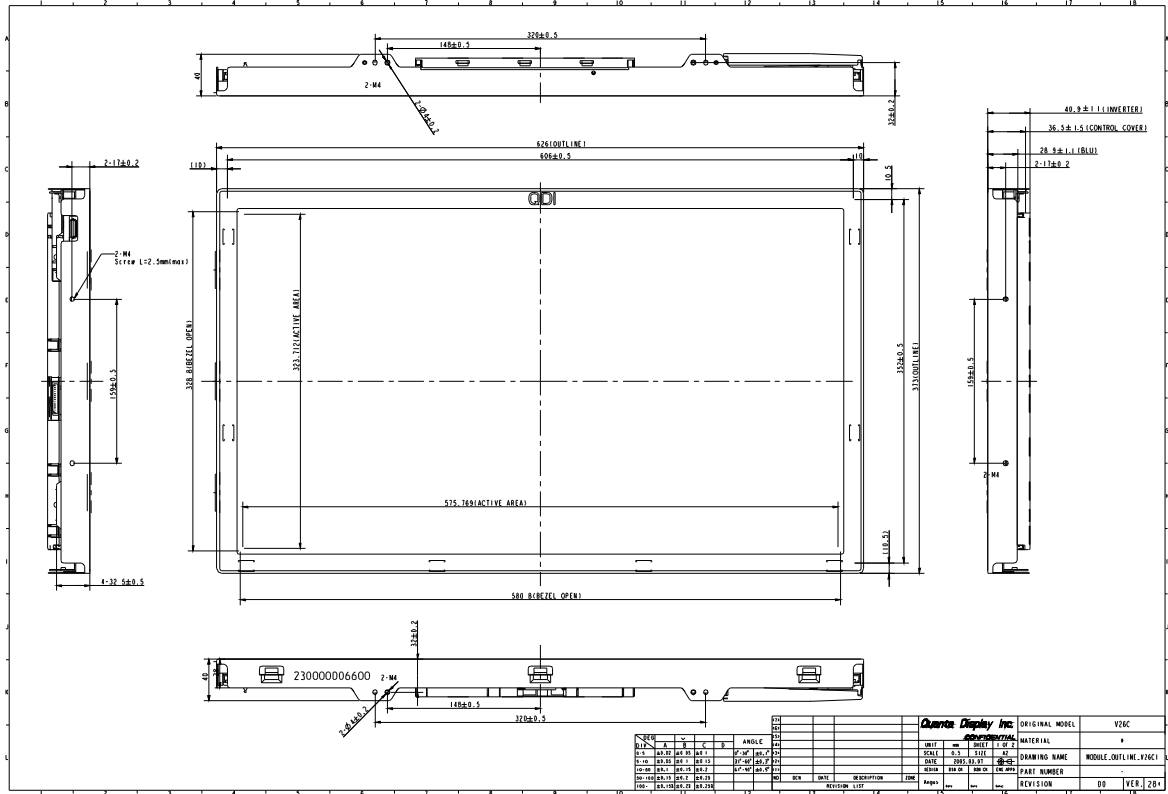

©Copyright AU Optronics, Inc.  
 Sep, 2006 All Rights Reserved.  
 No Reproduction and Redistribution Allowed

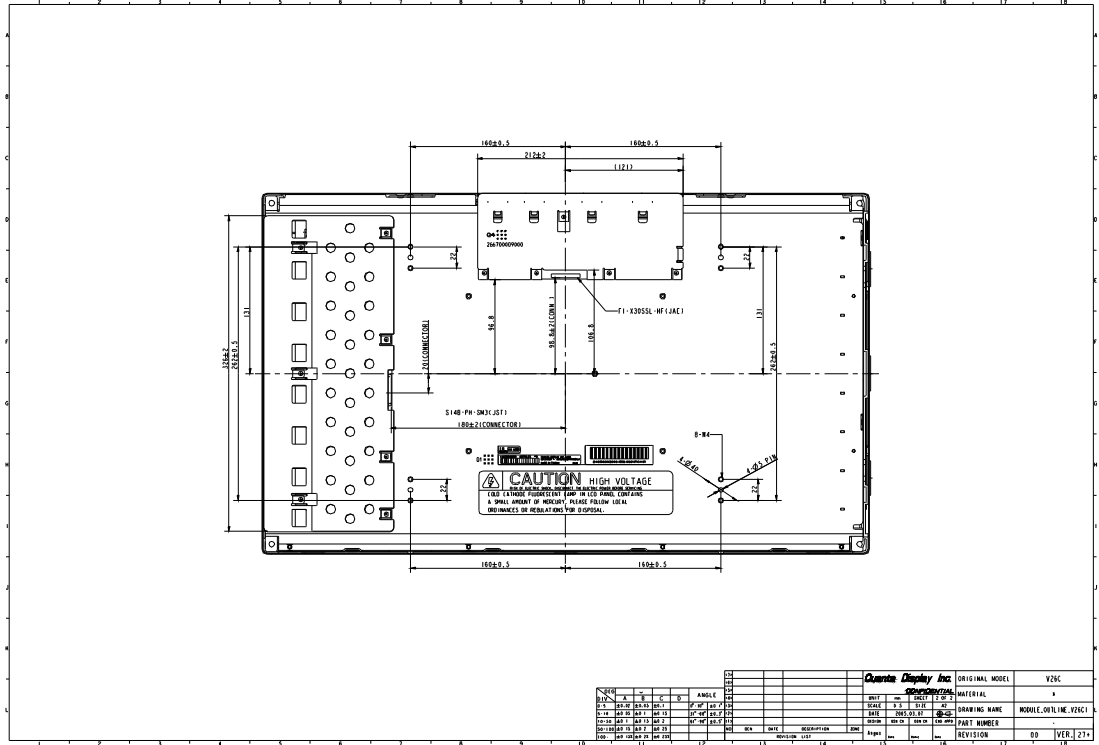

©Copyright AU Optronics, Inc.  
 Sep, 2006 All Rights Reserved.  
 No Reproduction and Redistribution Allowed