



Product Description: T260XW02 TFT-LCD PANEL	
AUO Model Name: T260XW02 VK	
Customer Part No/Project Name:	
<b>Customer Signature</b>	<b>Date</b>
	AUO
	Approved By: PM Sr.M anager/ Yu Chieh Lin <i>Jennifer Lin 1/12/2007</i>
	Reviewed By: RD Director/ Hong Jye Hong <i>Hong, Hong Jye 1/12 2007</i> Reviewed By: Project Leader/Bert Chen <i>Bert Chen</i>
	Prepared By: PM/Eric Chiang <i>Eric</i>



*Document Version: 0.0*

*Date: 2007/1/9*

## **Product Specifications**

**26.0" WXGA Color TFT-LCD Module**  
**Model Name: T260XW02 VK**

**() Preliminary Specifications**  
**(\* Final Specifications**



## Contents

No	ITEM
	COVER
	CONTENTS
	RECORD OF REVISIONS
<b>1</b>	GENERAL DESCRIPTION
<b>2</b>	ABSOLUTION MAXIMUM RATINGS
<b>3</b>	ELECTRICAL SPECIFICATIONS
<b>3-1</b>	ELECTRICAL CHARACTERISTICS
<b>3-2</b>	INTERFACE CONNECTIONS
<b>3-3</b>	BACKLIGHT CONNECTOR PIN CONFIGURATION
<b>3-4</b>	SIGNAL TIMING SPECIFICATIONS
<b>3-5</b>	SIGNAL TIMING WAVEFORMS
<b>3-6</b>	COLOR INPUT DATA REFERENCE
<b>3-7</b>	POWER SEQUENCE for LCD
<b>4</b>	OPTICAL SPECIFICATIONS
<b>5</b>	MECHANICAL CHARACTERISTICS
<b>6</b>	RELIABILITY
<b>7</b>	INTERNATIONAL STANDARDS
<b>7-1</b>	SAFETY
<b>7-2</b>	EMC
<b>7-3</b>	GREEN
<b>7-4</b>	EMI
<b>8</b>	PACKING
<b>9</b>	PRECAUTIONS



## Record of Revision

Version	Date	No	Old Description	New Description	Remark
0.0	2007/1/9		1st release		



## 1. General Description

This specification applies to the 26.0 inch Color TFT-LCD Module T260XW02. This LCD module has a TFT active matrix type liquid crystal panel 1366x768 pixels, and diagonal size of 26.0 inch. This module supports 1366x768 XGA-WIDE mode (Non-interlace).

Each pixel is divided into Red, Green and Blue sub-pixels or dots which are arranged in vertical stripes. Gray scale or the brightness of the sub-pixel color is determined with a 8-bit gray scale signal for each dot.

The T260XW02 has been designed to apply the 8-bit 1 channel LVDS interface method. It is intended to support displays where high brightness, wide viewing angle, high color saturation, and high color depth are very important.

### \* General Information

Items	Specification	Unit	Note
Active Screen Size	26.0	inches	
Display Area	575.769 (H) x 323.712(V)	mm	
Pixel Pitch	0.4215	mm	
Outline Dimension	626.0 (H) x 373.0 (V) x 46.2(D)	mm	With inverter
Driver Element	a-Si TFT active matrix		
Display Colors	16.7M	Colors	
Number of Pixels	1366 x 768	Pixel	
Pixel Arrangement	RGB vertical stripe		
Display Mode	Normally Black		
BL Structure	6 U-Lamps		
Surface Treatment	AG, 3H		
RoHS	RoHS compliance		



## 2. Absolute Maximum Ratings

The following are maximum values which, if exceeded, may cause faulty operation or damage to the unit.

Item	Symbol	Min	Max	Unit	Conditions
Logic/LCD Drive Voltage	Vcc	-0.3	13.5	[Volt]	Note 1
Input Voltage of Setup pin	Vin	-0.3	3.5	[Volt]	Note 1
Input Voltage of LVDS Signal	V	-0.3	2.5	[Volt]	Note 1
BLU Input Voltage	VDDDB	-0.3	27	[Volt]	Note 1
BLU Brightness Control Voltage	VBLON	-0.3	5	[Volt]	Note 1
Operating Temperature	TOP	0	+50	[°C]	Note 2
Operating Humidity	HOP	10	90	[%RH]	Note 3
Storage Temperature	TST	-20	+60	[°C]	Note 2
Storage Humidity	HST	10	90	[%RH]	Note 2
Panel Surface Temperature		-	65	[°C]	Note 2
PWM Duty Cycle			92%		

Note 1: Duration: 50 msec.

Note 2 : Maximum Wet-Bulb should be 39°C and No condensation.

Note 3 : Limited by inverter.

The relative humidity must not exceed 90% non-condensing at temperatures of 40°C or less. At temperatures greater than 40°C, the wet bulb temperature must not exceed 39°C.

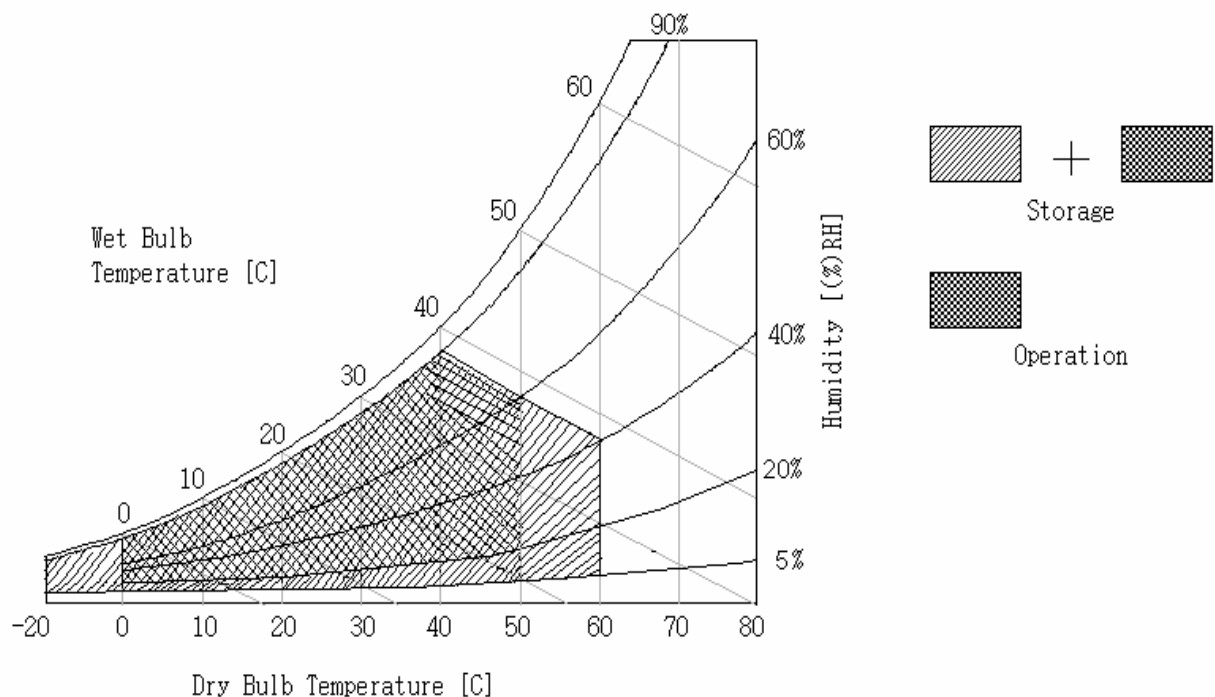



### 3. Electrical Specification

The T260XW02 requires two power inputs. One is employed to power the LCD electronics and to drive the TFT array and liquid crystal. The second input power for the BLU is to power inverter.

#### 3-1 Electrical Characteristics

Parameter			Values			Unit	Notes
			Min	Typ	Max		
LCD:							
Power Supply Input Voltage		Vcc	10.8	12	13.2	Vdc	1
Power Supply Input Current		Icc	-	0.5	-	A	2
Power Consumption		Pc	-	6	-	Watt	2
Inrush Current		I <sub>RUSH</sub>	-	-	3	Apeak	3
LVDS Interface	Differential Input High Threshold Voltage	VTH	-	-	+100	mV	4
	Differential Input Low Threshold Voltage	VTL	-100	-	-	mV	4
	Common Input Voltage	VCIM	0.6	1.2	1.8	V	
CMOS Interface	Input High Threshold Voltage	V <sub>IH</sub> (High)	2	-	-	Vdc	
	Input Low Threshold Voltage	V <sub>IL</sub> (Low)	-	-	0.8	Vdc	
Backlight Power Consumption		P <sub>DDDB</sub>	62	66	70	Watt	90% PWM dimming
Life Time			50,000	-	-	Hours	

#### Note:

1. The ripple voltage should be controlled under 10% of V<sub>CC</sub>
2. V<sub>cc</sub>=12.0V,  $f_v = 60\text{Hz}$ , f<sub>CLK</sub>=80Mhz, 25°C, Test Pattern : White Pattern
3. Measurement condition :

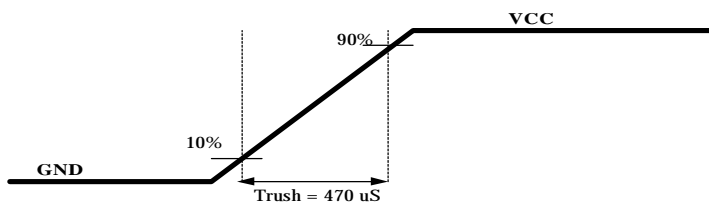



4.  $V_{CIM} = 1.2V$

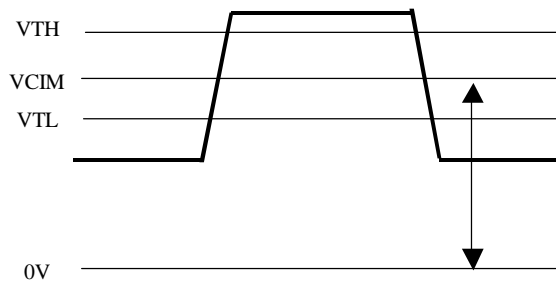

5. The performance of the Lamp in LCM, for example life time or brightness, is extremely influenced by the characteristics of the DC-AC Inverter. So all the parameters of an inverter should be carefully designed so as not to produce too much leakage current from high-voltage output of the inverter. When you design or order the inverter, please make sure unwanted lighting caused by the mismatch of the lamp and the inverter (no lighting, flicker, etc) never occurs. When you confirm it, the LCD Assembly should be operated in the same condition as installed in your instrument.
6. Do not attach a conducting tape to lamp connecting wire. If the lamp wire attach to conducting tape, TFT-LCD Module have a low luminance and the inverter has abnormal action because leakage current occurs between lamp wire and conducting tape.
7. The relative humidity must not exceed 80% non-condensing at temperatures of  $40^{\circ}C$  or less. At temperatures greater than  $40^{\circ}C$ , the wet bulb temperature must not exceed  $39^{\circ}C$ . When operate at low temperatures, the brightness of CCFL will drop and the life time of CCFL will be reduced.





### 3-2 Interface Connections (12V 1ch LVDS)

- LCD connector : FI-RE41S-HF (JAE)

PIN No.	Description	PIN No.	Description
1	VDD(12V)	21	RXCLK+
2	VDD	22	GND
3	VDD	23	RX3-
4	VDD	24	RX3+
5	VDD	25	GND
6	GND	26	NC
7	GND	27	NC
8	GND	28	NC
9	GND	29	Reserved
10	GND	30	Reserved
11	RX0-	31	NC
12	RX0+	32	NC
13	GND	33	NC
14	RX1-	34	NC
15	RX1+	35	NC
16	GND	36	NC
17	RX2-	37	NC
18	RX2+	38	NC
19	GND	39	Reserved
20	RXCLK-	40	Reserved
		41	Reserved

**Note:** All GND (ground) pins should be connected together and should also be connected to the LCD's metal frame.  
All Vcc (power input) pins should be connected together.

### Block Diagram

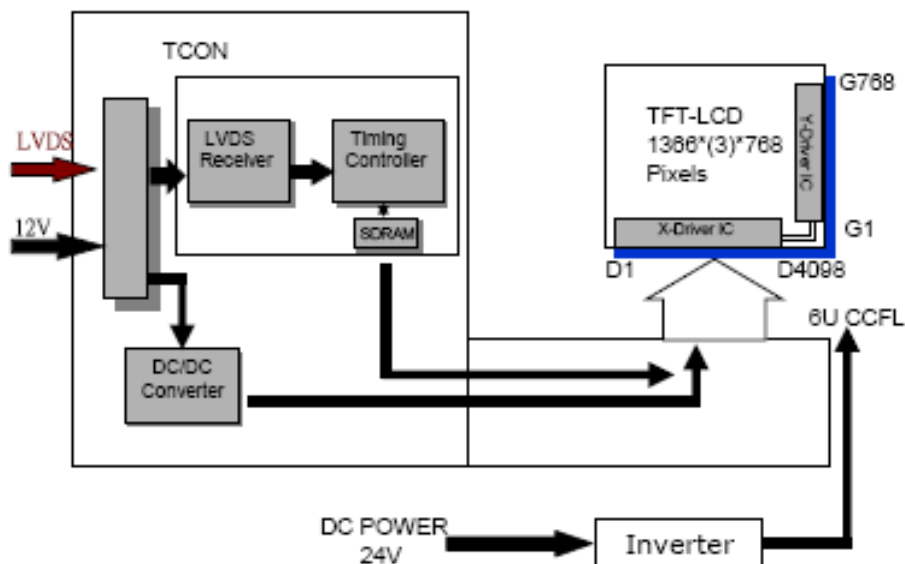



### 3-3 Backlight connector pin configuration

#### 3-3-1. Electrical specification

ITEM	SYMBOL	CONDITION	MIN	TYP	MAX	UNIT	Note	
Input Voltage	V <sub>DDB</sub>	---	23.0	24	26.4	VDC		
Input Current (Stable Condition)	I <sub>DDB</sub>	V <sub>DDB</sub> =24V	2.61	2.75	2.89	ADC	1	
Input Power (Stable Condition)	P <sub>DDB</sub>	V <sub>DDB</sub> =24V	62	66	70	W	1	
ON/OFF Control Voltage	V <sub>B<sub>LON</sub></sub>	ON	V <sub>DDB</sub> =24V	2	---	5	ADC	1
		OFF	V <sub>DDB</sub> =24V	0	---	0.8	VDC	
ON/OFF Control Current	I <sub>B<sub>LON</sub></sub>	V <sub>DDB</sub> =24V	-1	---	1.5	mADC		
PWM Dimming Control Voltage	V <sub>DIM</sub>	High	V <sub>DDB</sub> =24V	2	--	5	VDC	
		Low	V <sub>DDB</sub> =24V	0	--	0.8		

Note1: Condition : V<sub>DDB</sub>=24V (Ta=25±5°C, Turn on for 45minutes), PWM=90%

#### 3-3-2. Input specification

- Connector: S14B-PHA-SM-14 (JST)

No	Symbol	Description
1	V <sub>DDB</sub> (Main Power)	DC input 24.0 VDC
2	V <sub>DDB</sub> (Main Power)	DC input 24.0VDC
3	V <sub>DDB</sub> (Main Power)	DC input 24.0 VDC
4	V <sub>DDB</sub> (Main Power)	DC input 24.0 VDC
5	V <sub>DDB</sub> (Main Power)	DC input 24.0 VDC
6	GND	Ground
7	GND	Ground
8	GND	Ground
9	GND	Ground
10	GND	Ground
11	DET	Status : Operation="L", Fail="Open collector"
12	V <sub>B<sub>LON</sub></sub> (Enable Pin)	On/Off control Signal; 3.3V:On/ 0V:Off
13	NC	NC
14	V <sub>DIM</sub> (LCD Bright)	DIMMER : PWM (20%-90%)

Note:

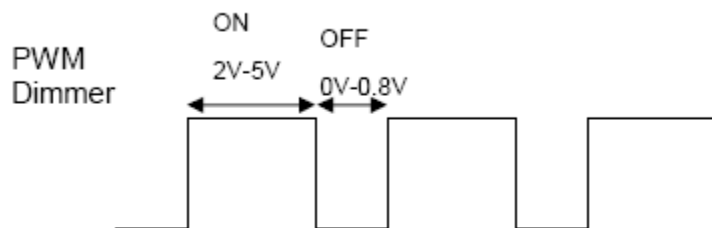

f(PWM)=120Hz-180Hz  
 Duty=ON/(ON+OFF)\*100% :



### 3-3-3. Backlight Diagram

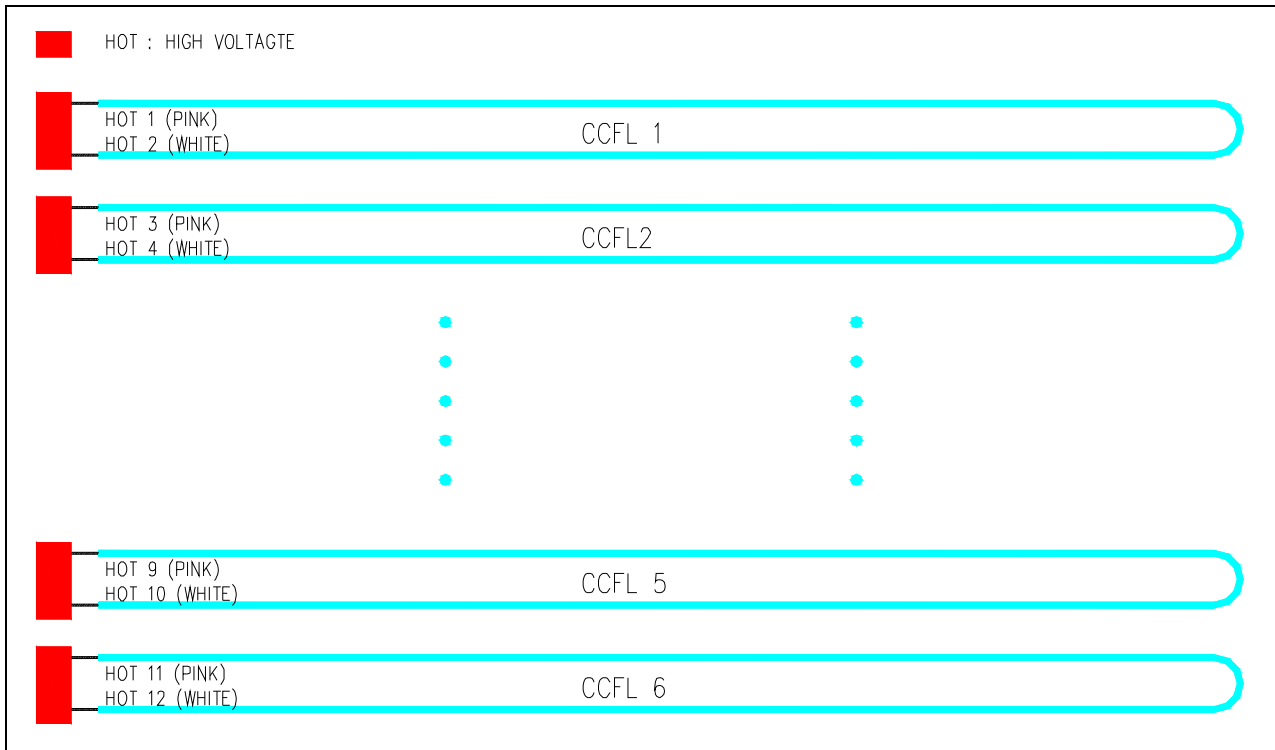



### 3-4 Signal Timing Specifications

This is the signal timing required at the input of the User connector. All of the interface signal timing should be satisfied with the following specifications for its proper operation

\* Timing Table

DE only Mode

Signal	Item	Symbol	Min	Typ.	Max	Unit
Vertical Section	V Total	T <sub>v</sub>	785	810	1000	Th
	Active	T <sub>disp(v)</sub>	768			Th
	Blanking	T <sub>blk(v)</sub>	17	42	232	Th
Horizontal Section	H Total	T <sub>h</sub>	1414	1648	1900	Tclk
	Active	T <sub>disp(h)</sub>	1366			Tclk
	Blanking	T <sub>blk(h)</sub>	48	282	534	Tclk
Pixel Clock	Frequency	1/Tclk	60	80	85	Mhz
Vertical Frequency	Frequency	F <sub>v</sub>	47	60	63	Hz
Horizontal Frequency	Frequency	F <sub>h</sub>	43	48	53	kHz

1. Display position is specific by the rise of DE signal only.
2. Horizontal display position is specified by the rising edge of 1<sup>st</sup> DCLK after the rise of 1<sup>st</sup> DE, is displayed on the left edge of the screen.
3. Vertical display position is specified by the rise of DE after a "Low" level period equivalent to eight times of horizontal period. The 1<sup>st</sup> data corresponding to one horizontal line after the rise the of 1<sup>st</sup> DE is displayed at the top line of screen.
4. If a period of DE "High" is less than 1366 DCLK or less than 768 lines, the rest of the screen displays black.
5. The display position does not fit to the screen if a period of DE "High" and the effective data period do not synchronize with each other.



### 3-5 Signal Timing Waveforms

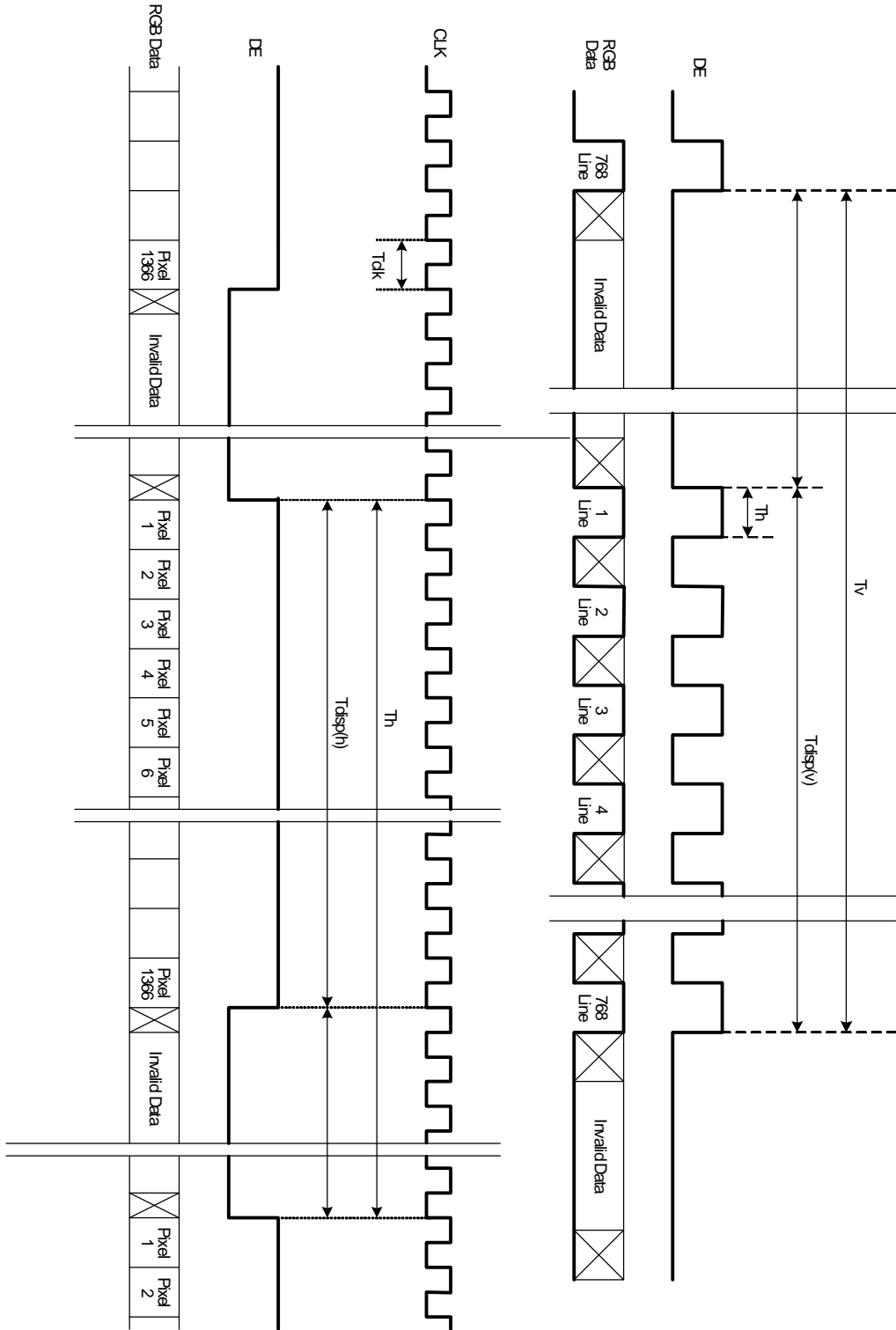



### 3-6 Color Input Data Reference

The brightness of each primary color (red, green and blue) is based on the 8 bit gray scale data input for the color; the higher the binary input, the brighter the color. The table below provides a reference for color versus data input.

#### COLOR DATA REFERENCE

Color		Input Color Data																							
		RED								GREEN								BLUE							
		MSB				LSB				MSB				LSB				MSB				LSB			
		R7	R6	R5	R4	R3	R2	R1	R0	G7	G6	G5	G4	G3	G2	G1	G0	B7	B6	B5	B4	B3	B2	B1	B0
Basic Color	Black	0	0	0	0	0	0	0	0	0	0	0	0	0	0	0	0	0	0	0	0	0	0	0	0
	Red(255)	1	1	1	1	1	1	1	1	0	0	0	0	0	0	0	0	0	0	0	0	0	0	0	0
	Green(255)	0	0	0	0	0	0	0	0	1	1	1	1	1	1	1	1	0	0	0	0	0	0	0	0
	Blue(255)	0	0	0	0	0	0	0	0	0	0	0	0	0	0	0	0	1	1	1	1	1	1	1	1
	Cyan	0	0	0	0	0	0	0	0	1	1	1	1	1	1	1	1	1	1	1	1	1	1	1	1
	Magenta	1	1	1	1	1	1	1	1	0	0	0	0	0	0	0	0	1	1	1	1	1	1	1	1
	Yellow	1	1	1	1	1	1	1	1	1	1	1	1	1	1	1	1	0	0	0	0	0	0	0	0
	White	1	1	1	1	1	1	1	1	1	1	1	1	1	1	1	1	1	1	1	1	1	1	1	1
RED	RED(000)	0	0	0	0	0	0	0	0	0	0	0	0	0	0	0	0	0	0	0	0	0	0	0	0
	RED(001)	0	0	0	0	0	0	0	1	0	0	0	0	0	0	0	0	0	0	0	0	0	0	0	0
	----																								
	RED(254)	1	1	1	1	1	1	1	0	0	0	0	0	0	0	0	0	0	0	0	0	0	0	0	0
	RED(255)	1	1	1	1	1	1	1	1	0	0	0	0	0	0	0	0	0	0	0	0	0	0	0	0
GREEN	GREEN(000)	0	0	0	0	0	0	0	0	0	0	0	0	0	0	0	0	0	0	0	0	0	0	0	0
	GREEN(001)	0	0	0	0	0	0	0	0	0	0	0	0	0	0	1	0	0	0	0	0	0	0	0	
	----																								
	GREEN(254)	0	0	0	0	0	0	0	0	1	1	1	1	1	1	0	0	0	0	0	0	0	0	0	
	GREEN(255)	0	0	0	0	0	0	0	0	1	1	1	1	1	1	1	0	0	0	0	0	0	0	0	
BLUE	BLUE(000)	0	0	0	0	0	0	0	0	0	0	0	0	0	0	0	0	0	0	0	0	0	0	0	0
	BLUE(001)	0	0	0	0	0	0	0	0	0	0	0	0	0	0	0	0	0	0	0	0	0	0	0	1
	-----																								
	BLUE(254)	0	0	0	0	0	0	0	0	0	0	0	0	0	0	0	0	1	1	1	1	1	1	1	0
	BLUE(255)	0	0	0	0	0	0	0	0	0	0	0	0	0	0	0	0	1	1	1	1	1	1	1	1



### 3-7 Power Sequence for LCD

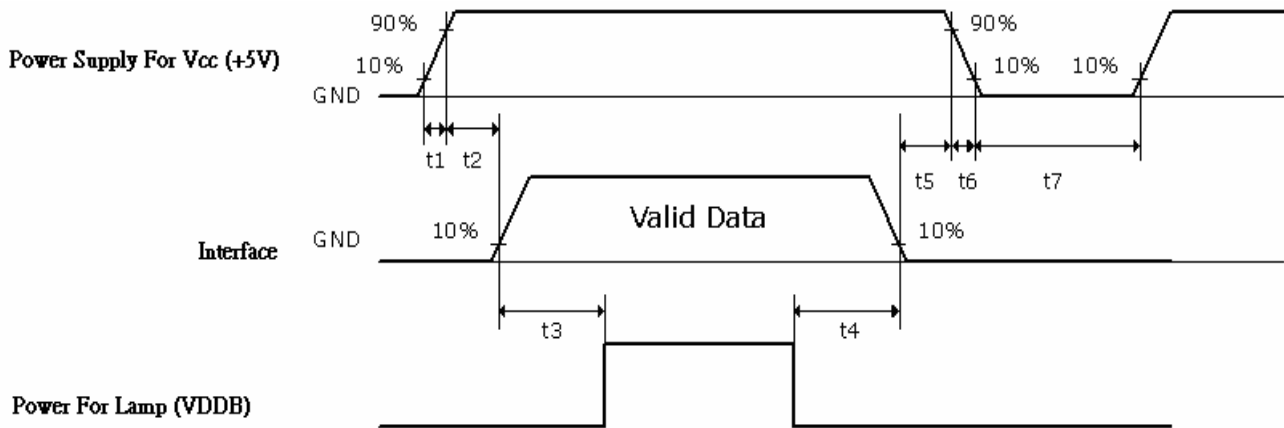

Parameter	Values			Units
	Min.	Typ.	Max.	
<b>t1</b>	0.47	-	30	ms
<b>t2</b>	5	-	50	ms
<b>t3</b>	500(note 2)	-	-	ms
<b>t4</b>	100	-	-	ms
<b>t5</b>	0.1	-	50	ms
<b>t6</b>	0.47	-	30	ms
<b>t7</b>	300	-	-	ms

Note 1: Apply the lamp voltage within the LCD operation range. When the back-light turns on before the LCD operation or the LCD turns off before the back-light turns off, the display may momentarily become abnormal screen.

Note 2:

- a. 200ms~550ms: Without turning color temperature might happen in this period
- b. >550ms: normal operation period, with color temperature turning



## 4. Optical Specification

Optical characteristics are determined after the unit has been 'ON' and stable for approximately 45 minutes in a dark environment at 25°C. The values specified are at an approximate distance 50cm from the LCD surface at a viewing angle of  $\Phi$  and  $\theta$  equal to 0°.

**Fig.1 Optical measurement equipment and method.**

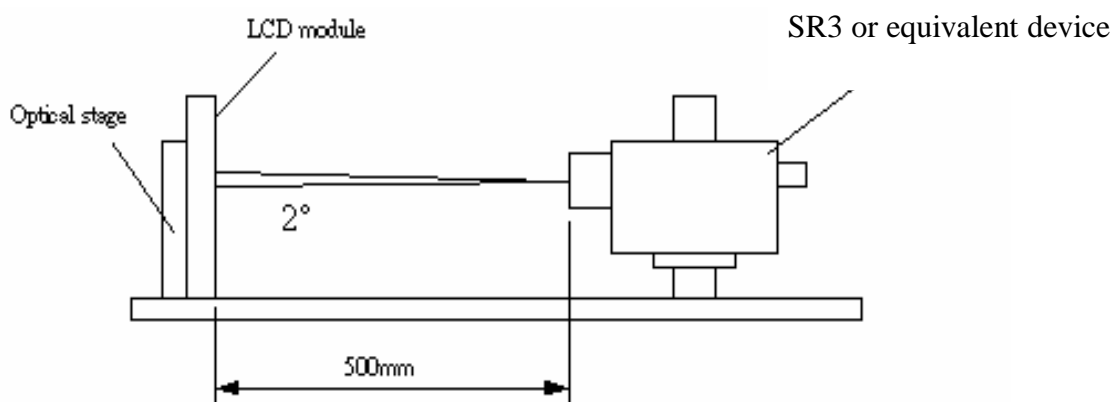

Parameter	Symbol	Values			Units	Notes
		Min.	Typ.	Max.		
Contrast Ratio	CR	1200	1500			1
Surface Luminance, white	L <sub>WH</sub>	420	500		cd/m <sup>2</sup>	2
Luminance Variation	$\delta_{\text{WHITE}}$ 9 p			1.3		3
Response Time Gray to Gray (Average)	T <sub><math>\gamma</math></sub>		8		ms	4,5
<b>Color Coordinates</b>						
	RED	R <sub>X</sub>	Typ.-0.03	0.650	Typ.+0.03	
		R <sub>Y</sub>		0.333		
	GREEN	G <sub>X</sub>		0.300		
		G <sub>Y</sub>		0.590		
	BLUE	B <sub>X</sub>		0.145		
		B <sub>Y</sub>		0.055		
	WHITE	W <sub>X</sub>		0.280		
		W <sub>Y</sub>		0.280		
Color Gamut	NTSC		72		%	
<b>Viewing Angle</b>						
	x axis, right( $\varphi=0^\circ$ )	$\theta_r$	75	89	Degree	6
	x axis, left( $\varphi=180^\circ$ )	$\theta_l$	75	89	Degree	
	y axis, up( $\varphi=90^\circ$ )	$\theta_u$	75	89	Degree	
	y axis, down ( $\varphi=0^\circ$ )	$\theta_d$	75	89	Degree	



**Note:**

1. Contrast Ratio (CR) is defined mathematically as:

$$\text{Contrast Ratio} = \frac{\text{Surface Luminance of } L_{\text{on1}}}{\text{Surface Luminance of } L_{\text{off1}}}$$

2. Surface luminance is luminance value at point 1 across the LCD surface 50cm from the surface with all pixels displaying white. From more information see FIG 2. When  $V_{\text{DDB}} = 24\text{V}$ ,  $I_{\text{DDB}} = 2.91\text{A}$ ,  $L_{\text{WH}} = L_{\text{on1}}$ . Where  $L_{\text{on1}}$  is the luminance with all pixels displaying white at center 1 location. PWM dimming=90%
3. The variation in surface luminance,  $\delta_{\text{WHITE}}$  is defined (center of Screen) as:
 
$$\delta_{\text{WHITE(9P)}} = \frac{\text{Maximum}(L_{\text{on1}}, L_{\text{on2}}, \dots, L_{\text{on9}})}{\text{Minimum}(L_{\text{on1}}, L_{\text{on2}}, \dots, L_{\text{on9}})}$$
4. Response time is the time required for the display to transition from black to white(Rise Time,  $\text{Tr}_\text{R}$ ) and from white to black (Decay Time,  $\text{Tr}_\text{D}$ ). For additional information see FIG3.
5.  $\text{T}\gamma$  is the response time between any two gray scale and is based on  $f_v = 60\text{Hz}$  to optimize.
6. Viewing angle is the angle at which the contrast ratio is greater than 10. The angles are determined for the horizontal or x axis and the vertical or y axis with respect to the z axis which is normal to the LCD surface. For more information see FIG4.

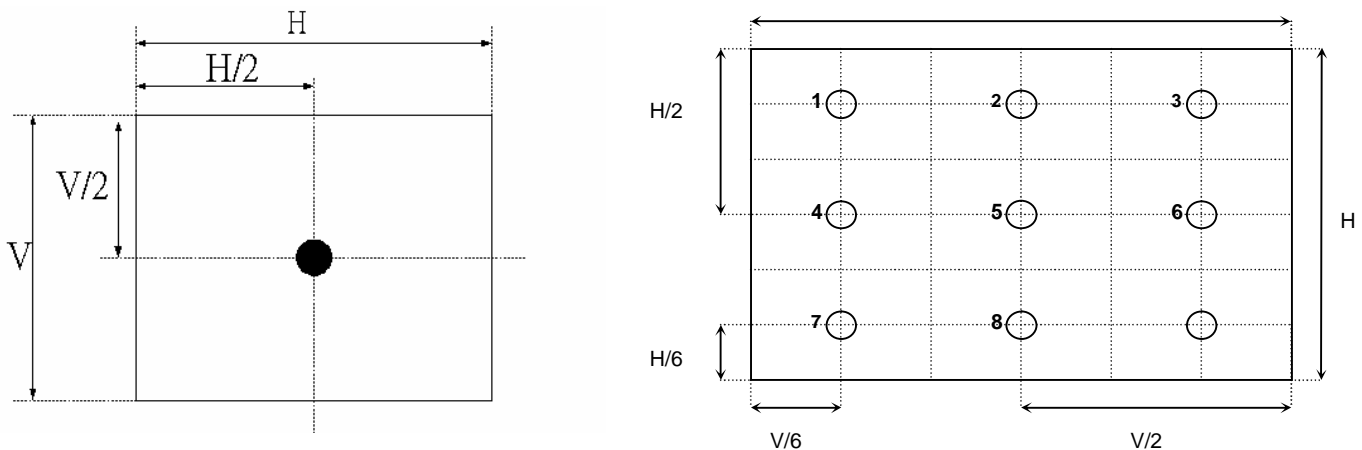
**FIG.2 Luminance**

**FIG.3 Response Time**

The response time is defined as the following figure and shall be measured by switching the input signal for “black” and “white”.

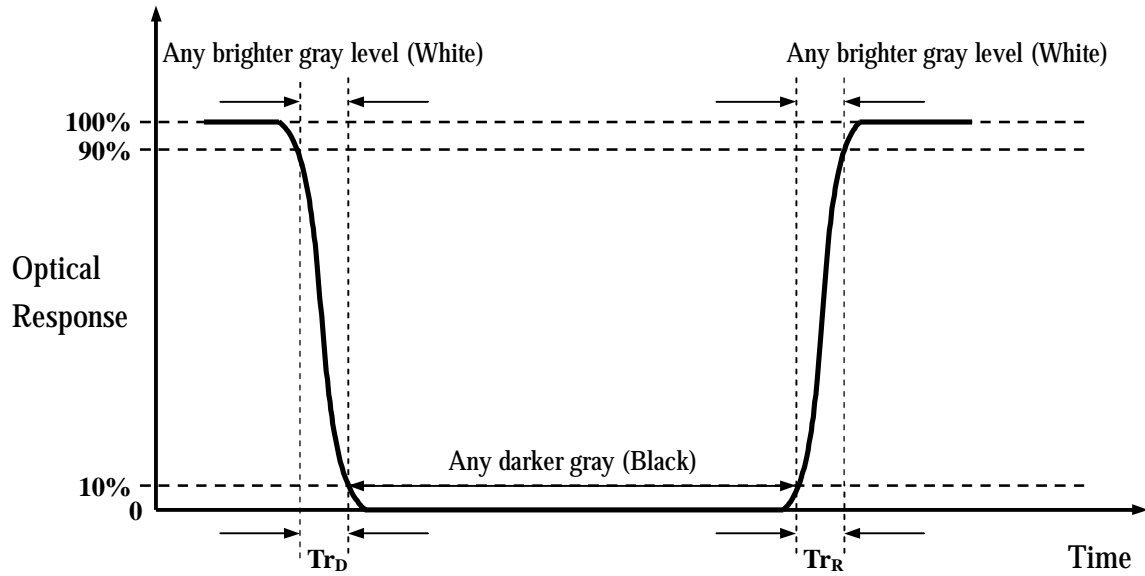
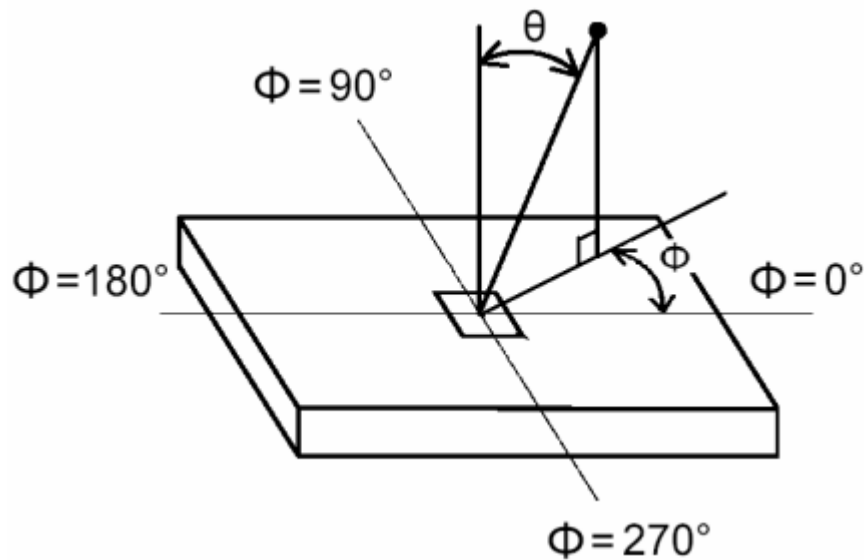
**FIG.4 Viewing angle**



## 5. Mechanical Characteristics

The contents provide general mechanical characteristics for the model T260XW02. In addition the figures in the next page are detailed mechanical drawing of the LCD.

<b>Outline Dimension</b>	Horizontal	626.0mm
	Vertical	373.0mm
	Depth	46.2mm(w/i inverter & shielding)
<b>Bezel Area</b>	Horizontal	581.8mm±0.5mm
	Vertical	328.8mm±0.5mm
<b>Active Display Area</b>	Horizontal	575.769mm
	Vertical	323.712mm
<b>Weight</b>	4,900g (Typ.)	
<b>Surface Treatment</b>	Anti-Glare, 3H	
<b>Torque on bottom chassis user holes (min affordable value)</b>	M3: 10Kgf-cm M4: 10Kgf-cm (by SONY screw)	



Front View

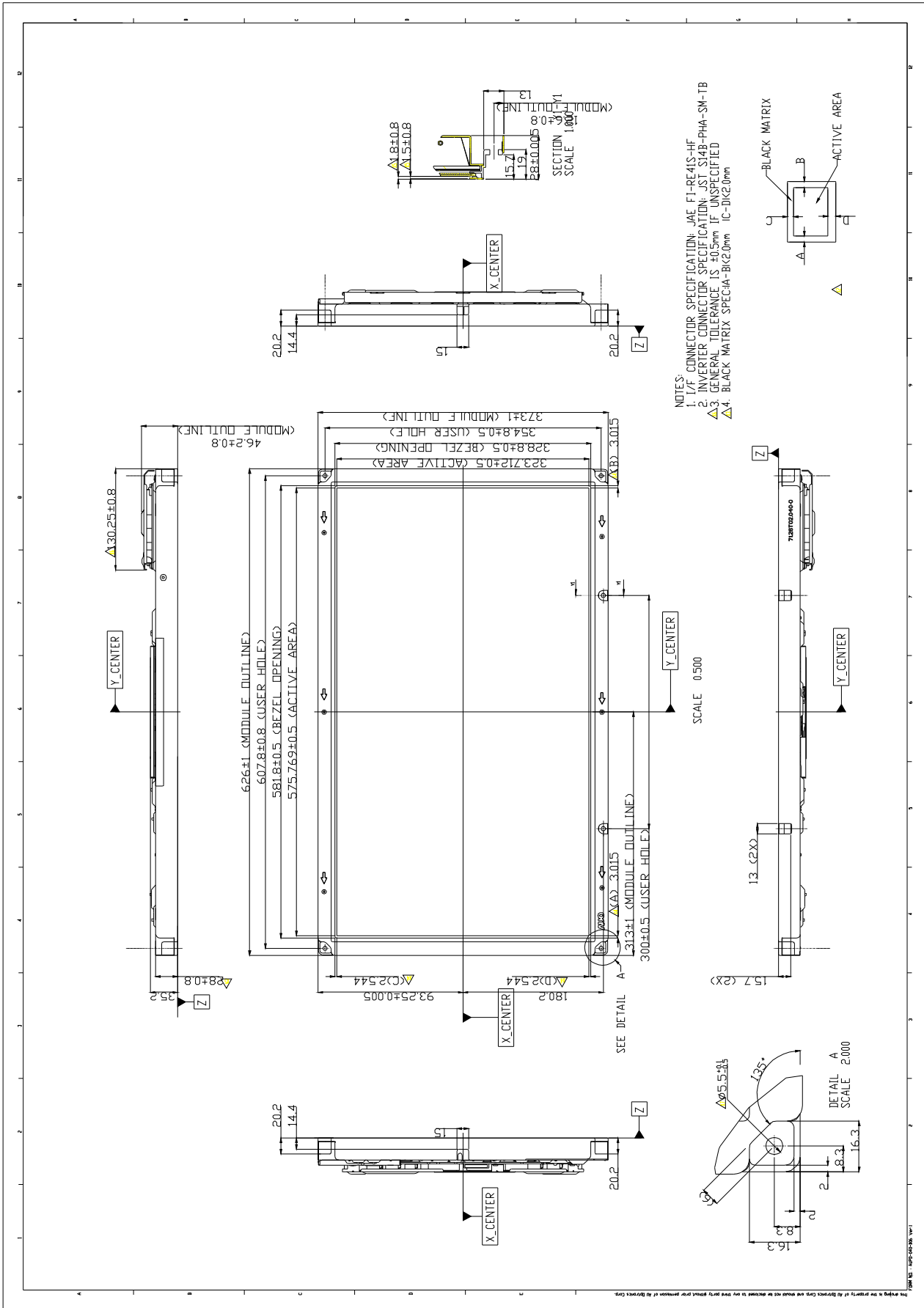





## 6. Reliability

Environment test condition

No	Test Item	Condition
1	High temperature storage test	Ta=60°C 300h judge
2	Low temperature storage test	Ta=-20°C 300h judge
3	High temperature operation test	Ta=50°C 80%RH 300h judge
4	Low temperature operation test	Ta=-5°C 300h judge
5	Vibration test (non-operating)	Wave form: Random Vibration level: 1.5G RMS Bandwidth: 10-300Hz Duration: X, Y, Z 30min each direction
6	Shock test (non-operating)	Shock level: 50G Waveform: half sine wave, 11ms Direction: ±X, ±Y, ±Z One time each direction
7	Vibration test (with carton)	Wave form: Random Vibration level: 1.5G, Bandwidth: 10~200Hz Duration: XYZ 30min each direction
8	Drop test (with carton)	Height: 31cm 1 corner, 3 edges, 6 surfaces (ASTMD4169-I)



## 7. International Standard

### 7-1 Safety



- (1) UL6500, Underwriters Laboratories, Inc. (AUO file number: E204356)  
Standard for Safety of Information Technology Equipment Including electrical Business Equipment.
- (2) CAN/CSA C22.2 No. 950-95 Third Edition, Canadian Standards Association, Jan. 28, 1995  
Standard for Safety of Information Technology Equipment Including Electrical Business Equipment.
- (3) EN60950: 1992+A2: 1993+A2: 1993+C3: 1995+A4: 1997+A11: 1997  
IEC 950: 1991+A1: 1992+A2: 1993+C3: 1995+A4:1996  
IEC 60065 (AUO Certificate number: JPTUV-008549)  
European Committee for Electro technical Standardization (CENELEC)  
EUROPEAN STANDARD for Safety of Information Technology Equipment Including Electrical Business Equipment.

### 7-2 EMC

- a) ANSI C63.4 “Methods of Measurement of Radio-Noise Emissions from Low-Voltage Electrical and Electrical Equipment in the Range of 9kHz to 40GHz. “American National standards Institute(ANSI), 1992.
- b) C.I.S.P.R “Limits and Methods of Measurement of Radio Interface Characteristics of Information Technology Equipment.” International Special committee on Radio Interference.
- c) EN 55022 “Limits and Methods of Measurement of Radio Interface Characteristics of Information Technology Equipment.” European Committee for Electrotechnical Standardization. (CENELEC), 1998.

### 7-3 Green

#### Green Mark Description:

- a) For Pb Free products, AUO will add  for identification.
- b) For RoHS compatible products, AUO will add  for identification.

**Note.** The Green Mark will be present only when the green documents have been ready by AUO Internal Green Team. (The definition of green design follows the AUO green design checklist.)

### 7-4 EMI

Item	Min	Typ	Max	Unit
EMI Level Note1)	-4	-6	---	dB(μV/m)
SSCG	300	----	---	ps

#### Note 1)

- a) Criteria: CISPR22
- b)Signal generator : PSG200-1(Sony EMCS)



## 8. Packing

Label sample 83mm \* 23mm



### Carton Label

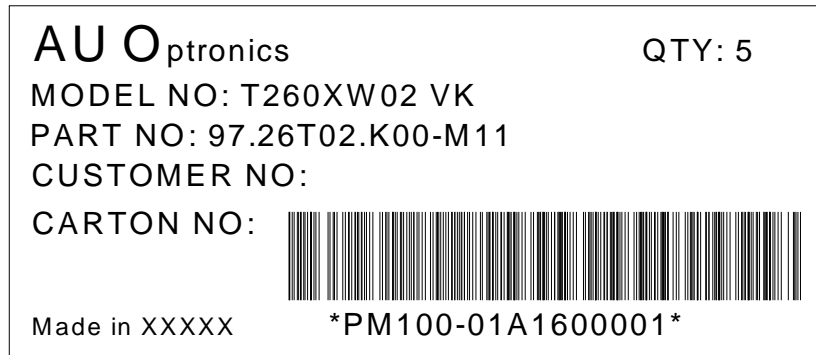





**Carton Size** 722(L) mm\*325(W) mm\*469(H) mm

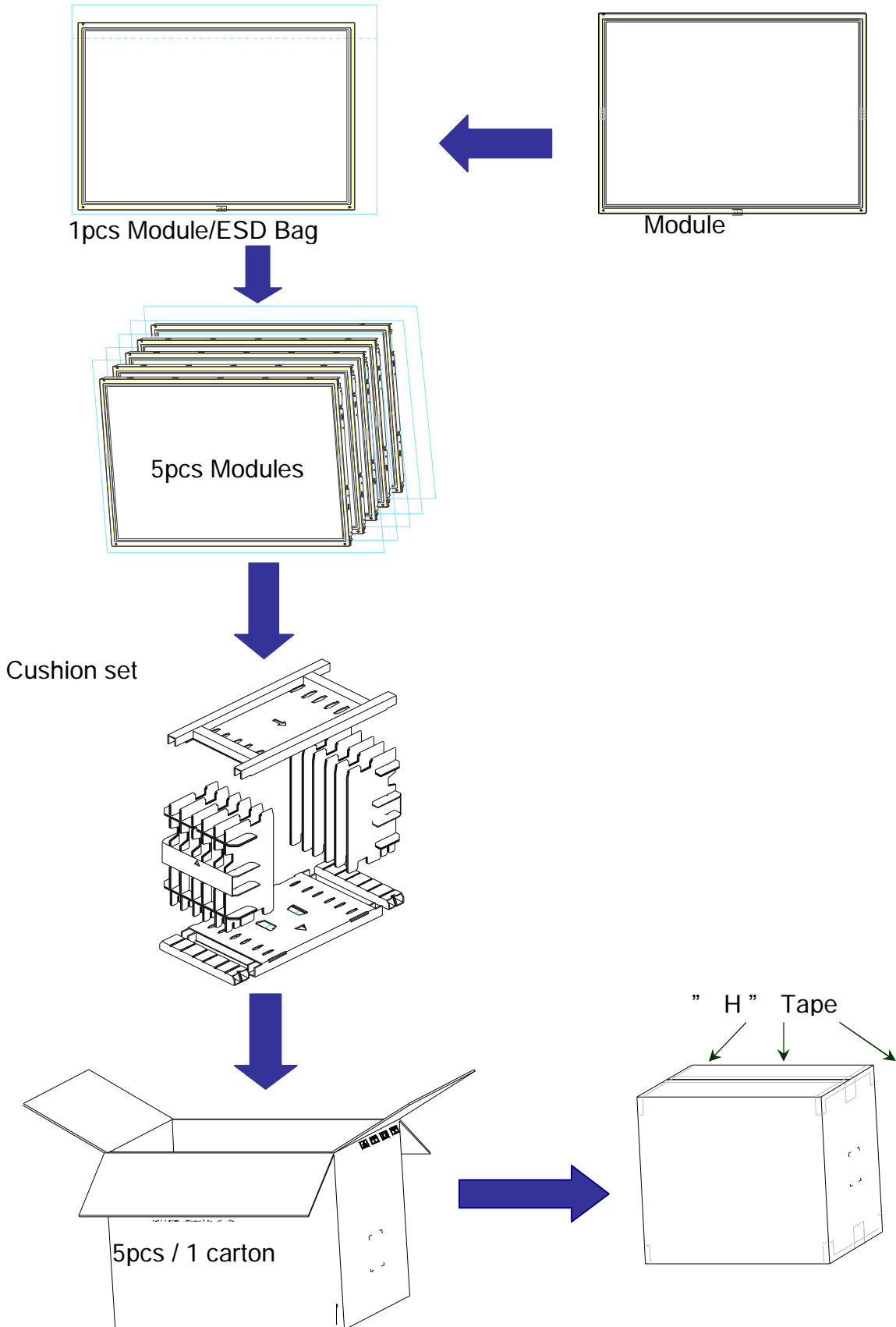



	Item	Specification			Packing Remark
		Qty.	Dimension	Weight (kg)	
1	Packing BOX	5 pcs/box	722(L)mm*325(W)mm*469(H)mm	28.4	
2	Pallet	1	980(L)mm*730(W)mm*120(H)mm		
3	Boxes per Pallet	6 boxes/Pallet			
4	Panels per Pallet	30 pcs/pallet			
5	Pallet after packing	30	980(L)mm*730(W)mm*1058(H)mm	180 .4	

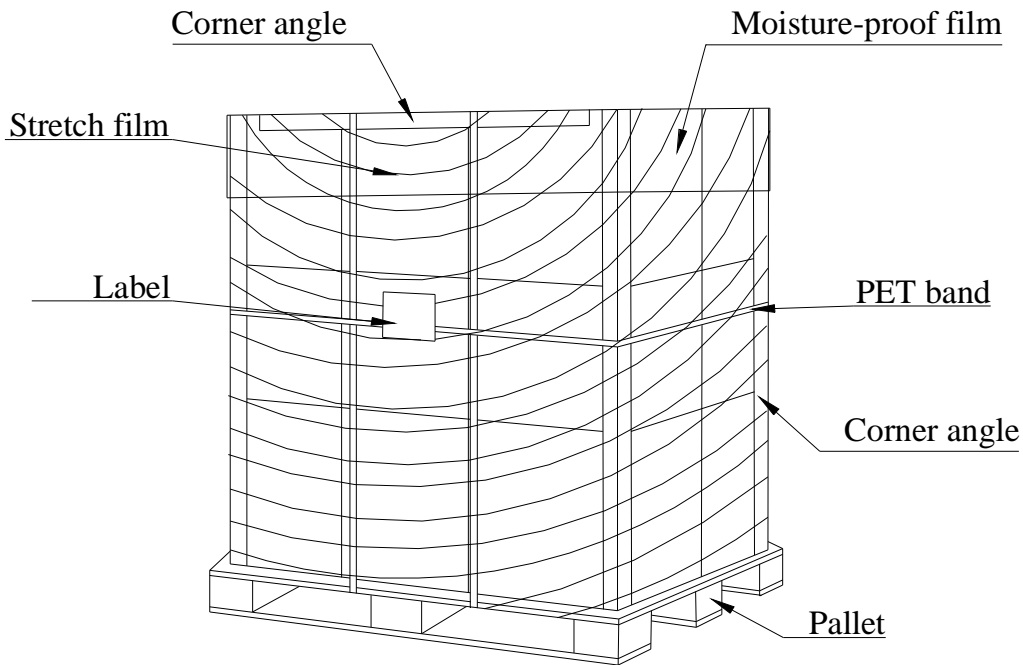



## 9. PRECAUTIONS

Please pay attention to the followings when you use this TFT LCD module.

### 9-1 Mounting precaution

- (1) You must mount a module using holes arranged in four corners or four sides.
- (2) You should consider the mounting structure so that uneven force (ex. Twisted stress) is not applied to module. And the case on which a module is mounted should have sufficient strength so that external force is not transmitted directly to the module.
- (3) Please attach the surface transparent protective plate to the surface in order to protect the polarizer. Transparent protective plate should have sufficient strength in order to resist external force.
- (4) You should adopt radiation structure to satisfy the temperature specification.
- (5) Acetic acid type and chlorine type materials for the cover case are not desirable because the former generates corrosive gas of attacking the polarizer at high temperature and the latter causes circuit break by electro-chemical reaction.
- (6) Do not touch, push or rub the exposed polarizers with glass, tweezers or anything harder than HB pencil lead. And please do not rub with dust clothes with chemical treatment. Do not touch the surface of polarizer for bare hand or greasy cloth. (Some cosmetics are detrimental to the polarizer.)
- (7) When the surface becomes dusty, please wipe gently with absorbent cotton or other soft materials like chamois soaks with petroleum benzene. Normal-hexane is recommended for cleaning the adhesives used to attach front/ rear polarizer. Do not use acetone, toluene and alcohol because they cause chemical damage to the polarizer.
- (8) Wipe off saliva or water drops as soon as possible. Their long time contact with polarizer causes deformations and color fading.
- (9) Do not open the case because inside circuits do not have sufficient strength.

### 9-2 Operation precautions

- (1) The spike noise causes the mis-operation of circuits. It should be lower than following voltage:  
 $V = \pm 200\text{mV}$  (Over and under shoot voltage)
- (2) Response time depends on the temperature. (In lower temperature, it becomes longer.)
- (3) Brightness depends on the temperature. (In lower temperature, it becomes lower.) And in lower temperature, response time (required time that brightness is stable after turned on) becomes longer.
- (4) Be careful for condensation at sudden temperature change. Condensation makes damage to polarizer or electrical contacted parts. And after fading condensation, smear or spot will occur.
- (5) When fixed patterns are displayed for a long time, remnant image is likely to occur.
- (6) Module has high frequency circuits. Sufficient suppression to the electromagnetic interference shall be done by system manufacturers. Grounding and shielding methods may be important to minimize the interface.



### **9-3 Electrostatic discharge control**

Since a module is composed of electronic circuits, it is not strong to electrostatic discharge. Make certain that treatment persons are connected to ground through wrist band etc. And don't touch interface pin directly.

### **9-4 Precautions for strong light exposure**

Strong light exposure causes degradation of polarizer and color filter.

### **9-5 Storage**

When storing modules as spares for a long time, the following precautions are necessary.

- (1) Store them in a dark place. Do not expose the module to sunlight or fluorescent light. Keep the temperature between 5°C and 35°C at normal humidity.
- (2) The polarizer surface should not come in contact with any other object. It is recommended that they be stored in the container in which they were shipped.

### **9-6 Handling precautions for protection film**

- (1) The protection film is attached to the bezel with a small masking tape. When the protection film is peeled off, static electricity is generated between the film and polarizer. This should be peeled off slowly and carefully by people who are electrically grounded and with well ion-blown equipment or in such a condition, etc.
- (2) When the module with protection film attached is stored for a long time, sometimes there remains a very small amount of glue still on the Bezel after the protection film is peeled off.
- (3) You can remove the glue easily. When the glue remains on the Bezel or its vestige is recognized, please wipe them off with absorbent cotton waste or other soft material like chamois soaked with normal-hexane.