

Document Version : 0.2

Date : 2008/12/5

Product Specifications

37" HDTV Color TFT-LCD Module

Model Name: T370HW02. VD

() Preliminary Specifications

(* Final Specifications

Contents

| No | |
|-----|---|
| | CONTENTS |
| | RECORD OF REVISIONS |
| 1 | GENERAL DESCRIPTION |
| 2 | ABSOLUTE MAXIMUM RATINGS |
| 3 | ELECTRICAL SPECIFICATIONS |
| 3-1 | ELECTRICAL CHARACTERISTICS |
| 3-2 | INTERFACE CONNECTIONS |
| 3-3 | SIGNAL TIMING SPECIFICATIONS |
| 3-4 | SIGNAL TIMING WAVEFORMS |
| 3-5 | COLOR INPUT DATA REFERENCE |
| 3-6 | POWER SEQUENCE |
| 3-7 | BACKLIGHT POWER SPECIFICATION FOR LCD MODULES |
| 4 | OPTICAL SPECIFICATIONS |
| 5 | MECHANICAL CHARACTERISTICS |
| 6 | RELIABILITY |
| 7 | INTERNATIONAL STANDARDS |
| 7-1 | SAFETY |
| 7-2 | EMC |
| 8 | PACKING |
| 9 | PRECAUTIONS |



Record of Revision

| Version | Date | No | Old Description | New Description | Remark |
|---------|---------|----|-----------------------------|-----------------|--------|
| 0 | 2008/11 | | First issue | | |
| 1 | 2008/11 | | Modify p.8 note 8 & drawing | | |
| 2. | 2008/12 | | Final spec | | |
| | | | | | |
| | | | | | |
| | | | | | |
| | | | | | |
| | | | | | |
| | | | | | |
| | | | | | |
| | | | | | |
| | | | | | |
| | | | | | |
| | | | | | |
| | | | | | |
| | | | | | |
| | | | | | |
| | | | | | |
| | | | | | |
| | | | | | |
| | | | | | |

www.panelook.com

1. General Description

This specification applies to the 37.0 inch Color TFT-LCD Module T370HW02 VD. This LCD module has a TFT active matrix type liquid crystal panel 1920*1080 pixels, and diagonal size of 37.0 inch. This module supports 1920*1080 HDTV mode (Non-interlace). Each pixel is divided into Red, Green and Blue sub-pixels or dots which are arranged in vertical stripes. Gray scale or the brightness of the sub-pixel color is determined with a 8-bit gray scale signal for each dot.

The T370HW02 VD has been designed to apply the 8-bit 2 channel LVDS interface method. It is intended to support displays where high brightness, wide viewing angle, high color saturation, and high color depth are very important.

The T370HW02 VD model is RoHS verified which can be distinguished on panel label.

* General Information

| Items | Specification | Unit | Note |
|------------------------|-----------------------------|--------|---------------|
| Active Screen Size | 37.01 | inch | |
| Display Area | 819.36 (H) x 460.89(V) | mm | |
| Outline Dimension | 877(H) x 514.6(V) x 54.3(D) | mm | With inverter |
| Driver Element | a-Si TFT active matrix | | |
| Display Colors | 8 bit, 16.7M | Colors | |
| Number of Pixels | 1920 x 1080 | Pixel | |
| Pixel Pitch | 0.42675(H) x 0.42675(W) | mm | |
| Pixel Arrangement | RGB vertical stripe | | |
| Display Operation Mode | Normally Black | | |
| Surface Treatment | Anti-Glare, 3H | | Haze = 11 |

2. Absolute Maximum Ratings

The following are maximum values which, if exceeded, may cause permanent damage to the unit.

| Item | Symbol | Min | Max | Unit | Conditions |
|--------------------------------|--------|------|-----|--------|------------|
| Logic/LCD Drive Voltage | Vcc | -0.3 | 14 | [Volt] | Note 1 |
| Input Voltage of Signal | Vin | -0.3 | 3.6 | [Volt] | Note 1 |
| BLU Input Voltage | VDDDB | -0.3 | 28 | [Volt] | Note 1 |
| BLU Brightness Control Voltage | Vdim | -0.3 | 7.0 | [Volt] | Note 1 |
| Operating Temperature | TOP | 0 | +50 | [°C] | Note 2 |
| Operating Humidity | HOP | 10 | 90 | [%RH] | Note 2 |
| Storage Temperature | TST | -20 | +60 | [°C] | Note 2 |
| Storage Humidity | HST | 10 | 90 | [%RH] | Note 2 |
| Panel Surface Temperature | PST | | 65 | [°C] | Note 3 |

Note 1: Duration:50 msec.

Note 2 : Maximum Wet-Bulb should be 39°C and No condensation.

The relative humidity must not exceed 90% non-condensing at temperatures of 40°C or less. At temperatures greater than 40°C, the wet bulb temperature must not exceed 39°C.

Note 3: Surface temperature is measured at 50°C Dry condition

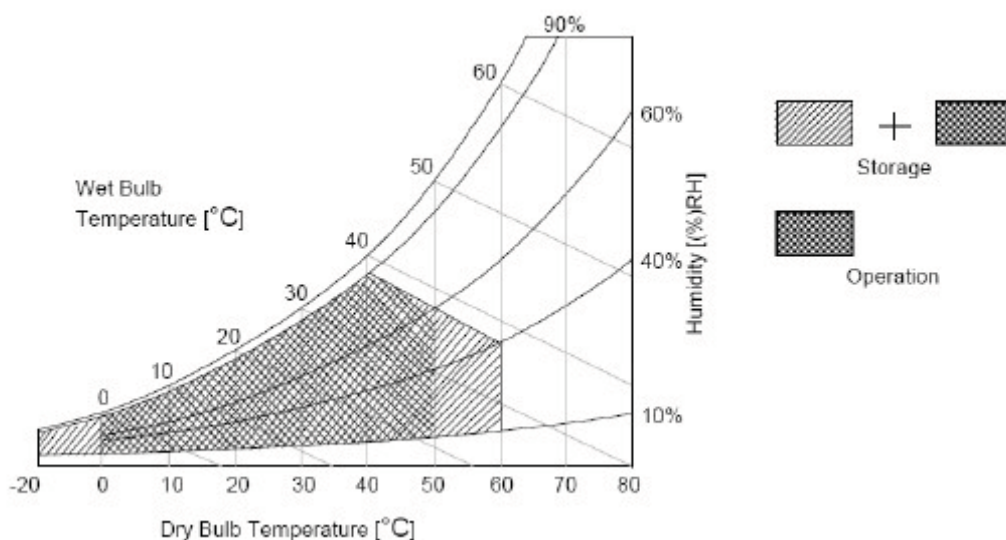

3. Electrical Specification

The T370HW02 VD requires two power inputs. One is employed to power the LCD electronics and to drive the TFT array and liquid crystal. The second input power for the BLU, is to power inverter. (INV)

3-1 Electrical Characteristics

| Parameter | | | Values | | | Unit | Notes |
|-----------------------------|---|---------------------------|--------|------|------|-------|-------|
| | | | Min | Typ | Max | | |
| LCD: | | | | | | | |
| Power Supply Input Voltage | | Vcc | 10.8 | 12 | 13.2 | Vdc | 1 |
| Power Supply Input Current | | Icc | - | 1.3 | | A | 2 |
| Power Consumption | | Pc | - | 15.5 | | Watt | 2 |
| Inrush Current | | I _{RUSH} | - | - | 3 | Apeak | 3 |
| LVDS Interface | Differential Input High Threshold Voltage | VTH | | | 100 | mV | 4 |
| | Differential Input Low Threshold Voltage | VTL | -100 | | | mV | 4 |
| | Common Input Voltage | VCIM | 1.13 | 1.20 | 1.38 | V | 4 |
| CMOS Interface | Input High Threshold Voltage | V _{IH} (High) | 2 | | | Vdc | |
| | Input Low Threshold Voltage | V _{IL} (Low) | | | 0.8 | Vdc | |
| Backlight Power Consumption | | P _{DDb} | 133 | 140 | 147 | Watt | |
| Life Time | | | 50,000 | | | Hours | 5.7.8 |

Note :

1. The ripple voltage should be controlled under 10% of V_{CC}
2. V_{cc}=12.0V, $f_v = 60\text{Hz}$, $f_{\text{CLK}}=81.5\text{Mhz}$, 25°C, Test Pattern : White Pattern
3. Measurement condition :

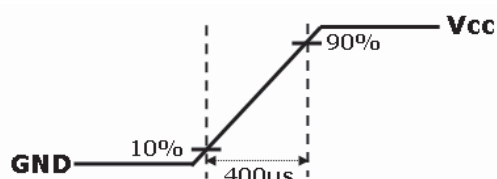

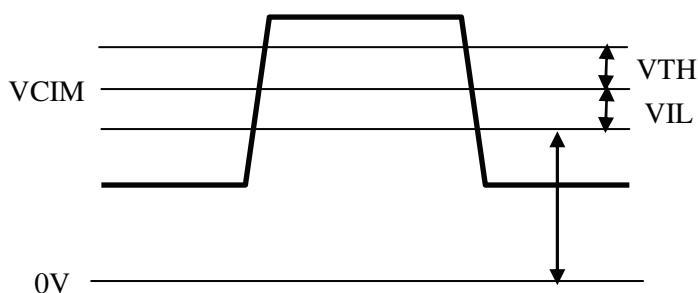
4. $V_{CIM} = 1.2V$ 

5. The performance of the Lamp in LCD panel, for example life time or brightness, is extremely influenced by the characteristics of the DC-AC Inverter. So all the parameters of an inverter should be carefully designed as not to produce too much leakage current from high-voltage output of the inverter. When you design or order the inverter, please make sure unwanted lighting caused by the mismatch of the lamp and the inverter (no lighting, flicker, etc) never occurs. After confirmation, the LCD panel should be operated in the same condition as installed in your instrument.
6. Do not attach a conducting tape to lamp connecting wire. If the lamp wire attach to conducting tape, TFT-LCD Module have a low luminance and the inverter has abnormal action because leakage current occurs between lamp wire and conducting tape.
7. The relative humidity must not exceed 80% non-condensing at temperatures of 40°C or less. At temperatures greater than 40°C, the wet bulb temperature must not exceed 39°C. When operate at low temperatures, the brightness of CCFL will drop and the life time of CCFL will be reduced.
8. Specified values are for a single lamp only which is aligned horizontally. The lifetime is defined as the time which luminance of the lamp is 50% compared to its original value.

[Operating condition: Continuous operating at $T_a = 25 \pm 2^\circ\text{C}$]

3-2 Interface Connections

LCD connector (CN1): JAE FI-RE51S-HF

| Pin | Symbol | I/O | Remark |
|-----|-----------|-----|---------------|
| 1 | VDD (12V) | I | Power |
| 2 | VDD (12V) | I | Power |
| 3 | VDD (12V) | I | Power |
| 4 | VDD (12V) | I | Power |
| 5 | VDD (12V) | I | Power |
| 6 | NC | | No connection |
| 7 | GND | I | GND |
| 8 | GND | I | GND |
| 9 | GND | I | GND |
| 10 | RAX0- | I | LVDS RAN |
| 11 | RAX0+ | I | LVDS RAP |
| 12 | RAX1- | I | LVDS RBN |
| 13 | RAX1+ | I | LVDS RBP |
| 14 | RAX2- | I | LVDS RCN |
| 15 | RAX2+ | I | LVDS RCP |
| 16 | GND | I | GND |
| 17 | RAXCLK- | I | LVDS RCLKN |
| 18 | RAXCLK+ | I | LVDS RCLKP |
| 19 | GND | I | GND |
| 20 | RAX3- | I | LVDS RDN |
| 21 | RAX3+ | I | LVDS RDP |
| 22 | RAX4- | I | LVDS REN |
| 23 | RAX4+ | I | LVDS REP |
| 24 | GND | I | GND |
| 25 | RBX0- | I | LVDS RAN |
| 26 | RBX0+ | I | LVDS RAP |
| 27 | RBX1- | I | LVDS RBN |
| 28 | RBX1+ | I | LVDS RBP |
| 29 | RBX2- | I | LVDS RCN |
| 30 | RBX2+ | I | LVDS RCP |
| 31 | GND | I | GND |
| 32 | RBXCLK- | I | LVDS RCLKN |
| 33 | RBXCLK+ | I | LVDS RCLKP |

| | | | |
|----|----------|-----|---|
| 34 | GND | I | GND |
| 35 | RBX3- | I | LVDS RDN |
| 36 | RBX3+ | I | LVDS RDP |
| 37 | RBX4- | I | LVDS REN |
| 38 | RBX4+ | I | LVDS REP |
| 39 | GND | I | GND |
| 40 | TCON_SCL | I | I2C clock |
| 41 | TCON_SDA | I/O | I2C data |
| 42 | NC | | No connection |
| 43 | BUS_SW | I | I2C bus enable (H/Open:enable, L:disable) |
| 44 | T_BINT1 | I | I2C bus enable (H/Open:enable, L:disable) |
| 45 | SET-ON2 | I | Power on sequence |
| 46 | SA-MODE | I | Standalone mode (H/Open:Standalone mode, L:Standard mode) |
| 47 | PANEL-ON | I | Power on sequence |
| 48 | RESET | I | Reset (H:Reset On, L/Open:Release) |
| 49 | NC | | No connection |
| 50 | TCONRDY | O | TCON ready signal (H:OK, L:NG) |
| 51 | VCA | I | Vcom Adjustment mode (H:Normal mode, L:VCA mode) |

LVDS / Mini-LVDS mapping

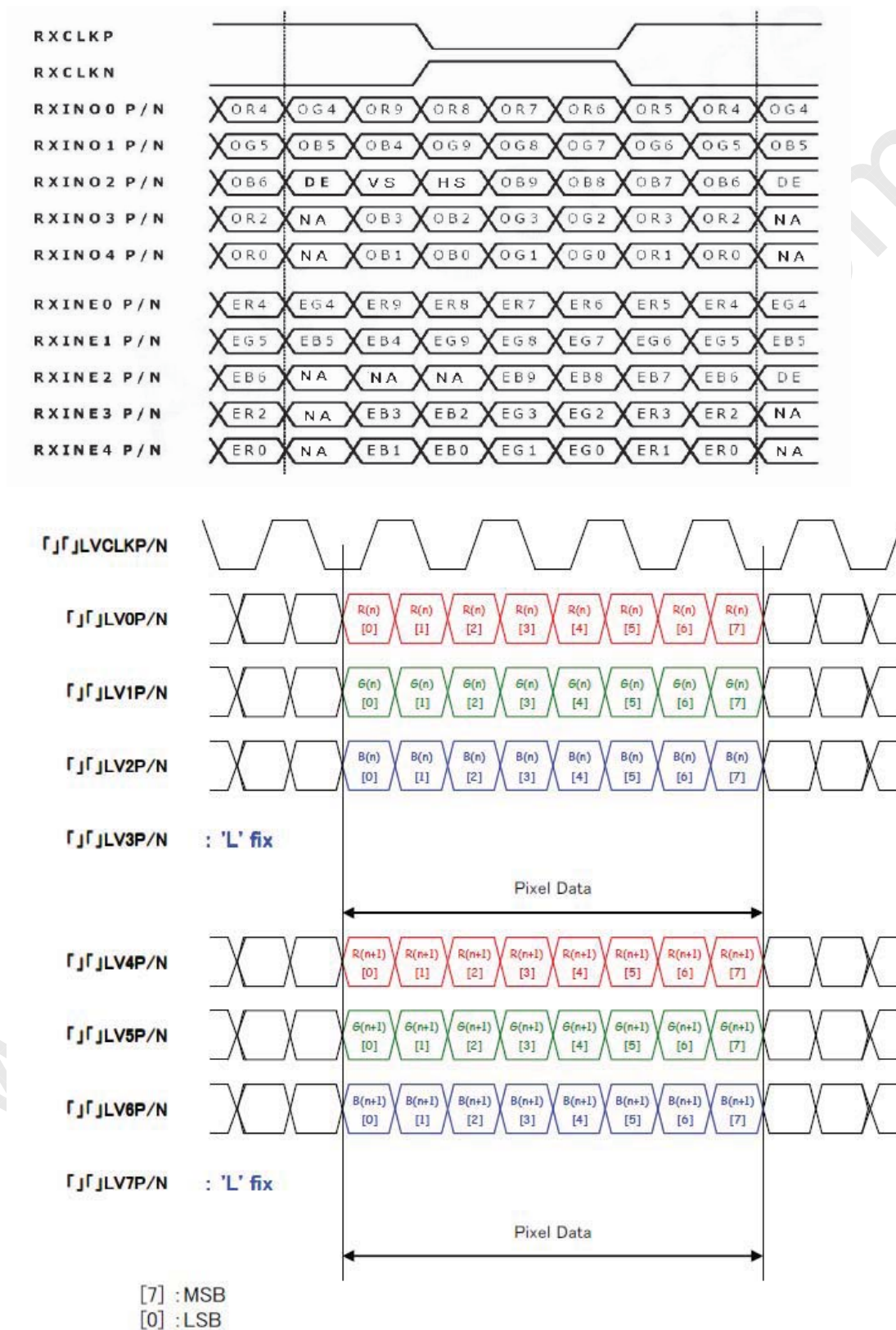

3-3 Signal Timing Specifications

This is the signal timing required at the input of the User connector. All of the interface signal timing should be satisfied with the following specifications for it's proper operation.

| Symbol | Unit | AUO TEST (SA MODE) | | | Remark |
|--------|--------|--------------------|-------------|---------|--------|
| PCLK | [MHz] | 73(min) | 74.47(typ.) | 75(max) | |
| Hfreq | [kHz] | 67.455 | | | |
| Vfreq | [Hz] | 59.96 | | | |
| | | | | | |
| Htotal | [CLK] | 2208 | | | |
| Hact | [CLK] | 1920 | | | |
| H_FP | [CLK] | 48 | | | |
| H_BP | [CLK] | 208 | | | |
| Hsync | [CLK] | 32 | | | |
| | | | | | |
| Vtotal | [Line] | 1125 | | | |
| Vact | [Line] | 1080 | | | |
| V_FP | [Line] | 19 | | | |
| V_BP | [Line] | 22 | | | |
| Vsync | [Line] | 4 | | | |

3-4 Signal Timing Waveforms

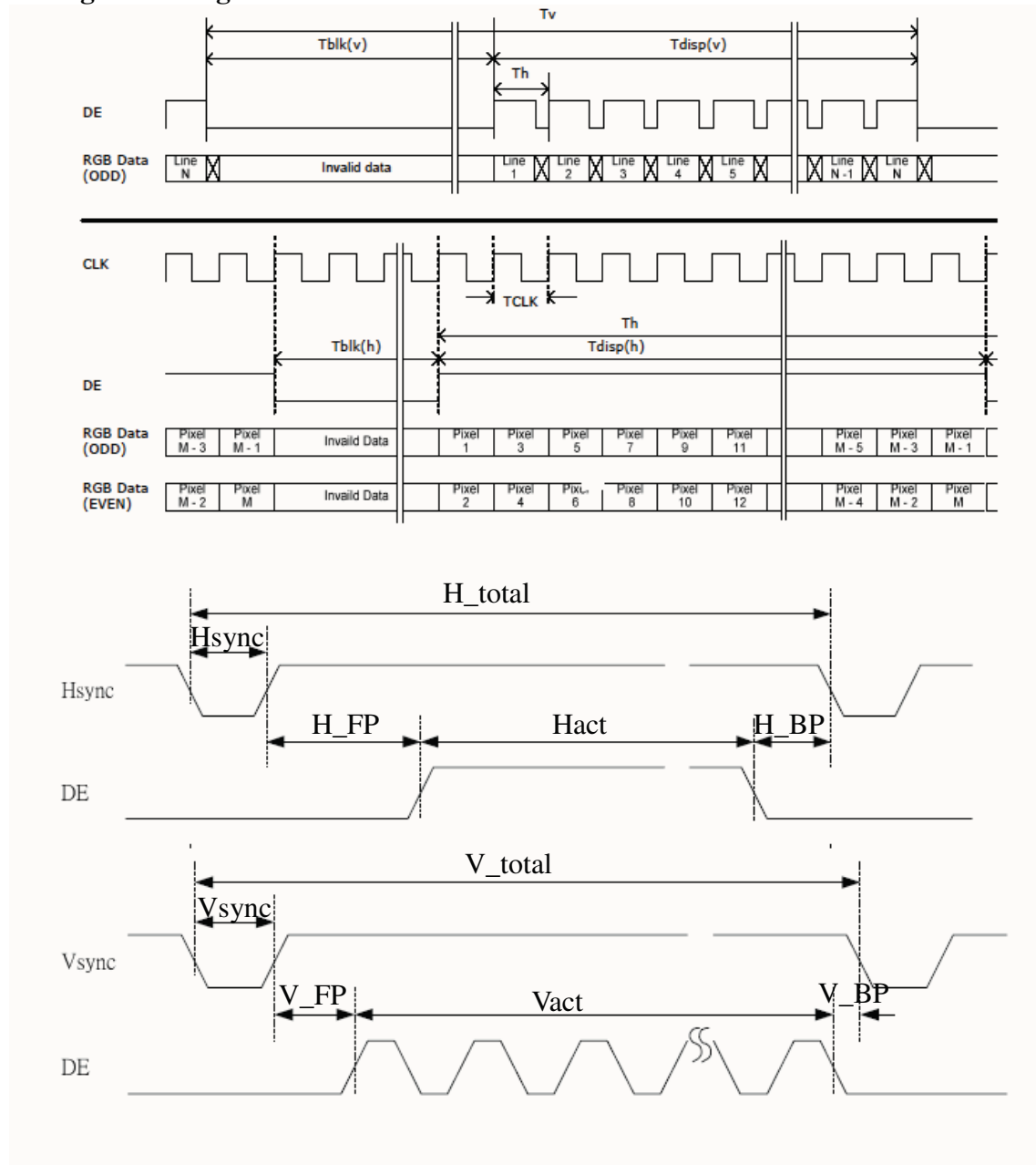

www

3-5 Color Input Data Reference

The brightness of each primary color (red, green and blue) is based on the 8 bit gray scale data input for the color; the higher the binary input, the brighter the color. The table below provides a reference for color versus data input.

COLOR DATA REFERENCE

| color | | Input Color data | | | | | | | | | | | | | | | | | | | | | | | | | | | |
|-------------|-------------|------------------|----|----|----|----|----|----|----|-------|----|----|----|----|----|----|----|------|----|----|----|----|----|----|----|---|---|---|---|
| | | Red | | | | | | | | Green | | | | | | | | Blue | | | | | | | | | | | |
| | | R0 | R1 | R2 | R3 | R4 | R5 | R6 | R7 | G0 | G1 | G2 | G3 | G4 | G5 | G6 | G7 | B0 | B1 | B2 | B3 | B4 | B5 | B6 | B7 | | | | |
| Basic color | Black | 0 | 0 | 0 | 0 | 0 | 0 | 0 | 0 | 0 | 0 | 0 | 0 | 0 | 0 | 0 | 0 | 0 | 0 | 0 | 0 | 0 | 0 | 0 | 0 | 0 | 0 | 0 | 0 |
| | Red (255) | 1 | 1 | 1 | 1 | 1 | 1 | 1 | 1 | 0 | 0 | 0 | 0 | 0 | 0 | 0 | 0 | 0 | 0 | 0 | 0 | 0 | 0 | 0 | 0 | 0 | 0 | 0 | |
| | Green (255) | 0 | 0 | 0 | 0 | 0 | 0 | 0 | 0 | 1 | 1 | 1 | 1 | 1 | 1 | 1 | 1 | 0 | 0 | 0 | 0 | 0 | 0 | 0 | 0 | 0 | 0 | 0 | |
| | Blue (255) | 0 | 0 | 0 | 0 | 0 | 0 | 0 | 0 | 0 | 0 | 0 | 0 | 0 | 0 | 0 | 0 | 1 | 1 | 1 | 1 | 1 | 1 | 1 | 1 | 1 | 1 | 1 | |
| | Cyan | 0 | 0 | 0 | 0 | 0 | 0 | 0 | 0 | 1 | 1 | 1 | 1 | 1 | 1 | 1 | 1 | 1 | 1 | 1 | 1 | 1 | 1 | 1 | 1 | 1 | 1 | 1 | |
| | Magenta | 1 | 1 | 1 | 1 | 1 | 1 | 1 | 1 | 0 | 0 | 0 | 0 | 0 | 0 | 0 | 0 | 1 | 1 | 1 | 1 | 1 | 1 | 1 | 1 | 1 | 1 | 1 | |
| | Yellow | 1 | 1 | 1 | 1 | 1 | 1 | 1 | 1 | 1 | 1 | 1 | 1 | 1 | 1 | 1 | 1 | 0 | 0 | 0 | 0 | 0 | 0 | 0 | 0 | 0 | 0 | 0 | |
| | White | 1 | 1 | 1 | 1 | 1 | 1 | 1 | 1 | 1 | 1 | 1 | 1 | 1 | 1 | 1 | 1 | 1 | 1 | 1 | 1 | 1 | 1 | 1 | 1 | 1 | 1 | 1 | |
| Red | 000 | 0 | 0 | 0 | 0 | 0 | 0 | 0 | 0 | 0 | 0 | 0 | 0 | 0 | 0 | 0 | 0 | 0 | 0 | 0 | 0 | 0 | 0 | 0 | 0 | 0 | 0 | 0 | |
| | 001 | 1 | 0 | 0 | 0 | 0 | 0 | 0 | 0 | 0 | 0 | 0 | 0 | 0 | 0 | 0 | 0 | 0 | 0 | 0 | 0 | 0 | 0 | 0 | 0 | 0 | 0 | | |
| | 254 | 0 | 1 | 1 | 1 | 1 | 1 | 1 | 1 | 0 | 0 | 0 | 0 | 0 | 0 | 0 | 0 | 0 | 0 | 0 | 0 | 0 | 0 | 0 | 0 | 0 | 0 | | |
| | 255 | 1 | 1 | 1 | 1 | 1 | 1 | 1 | 1 | 0 | 0 | 0 | 0 | 0 | 0 | 0 | 0 | 0 | 0 | 0 | 0 | 0 | 0 | 0 | 0 | 0 | 0 | | |
| | 000 | 0 | 0 | 0 | 0 | 0 | 0 | 0 | 0 | 0 | 0 | 0 | 0 | 0 | 0 | 0 | 0 | 0 | 0 | 0 | 0 | 0 | 0 | 0 | 0 | 0 | 0 | | |
| Green | 001 | 0 | 0 | 0 | 0 | 0 | 0 | 0 | 0 | 1 | 0 | 0 | 0 | 0 | 0 | 0 | 0 | 0 | 0 | 0 | 0 | 0 | 0 | 0 | 0 | 0 | 0 | | |
| | 254 | 0 | 0 | 0 | 0 | 0 | 0 | 0 | 0 | 0 | 1 | 1 | 1 | 1 | 1 | 1 | 1 | 0 | 0 | 0 | 0 | 0 | 0 | 0 | 0 | 0 | 0 | | |
| | 255 | 0 | 0 | 0 | 0 | 0 | 0 | 0 | 0 | 1 | 1 | 1 | 1 | 1 | 1 | 1 | 1 | 0 | 0 | 0 | 0 | 0 | 0 | 0 | 0 | 0 | 0 | | |
| | 000 | 0 | 0 | 0 | 0 | 0 | 0 | 0 | 0 | 0 | 0 | 0 | 0 | 0 | 0 | 0 | 0 | 0 | 0 | 0 | 0 | 0 | 0 | 0 | 0 | 0 | 0 | | |
| | 001 | 0 | 0 | 0 | 0 | 0 | 0 | 0 | 0 | 0 | 0 | 0 | 0 | 0 | 0 | 0 | 0 | 1 | 0 | 0 | 0 | 0 | 0 | 0 | 0 | 0 | 0 | | |
| Blue | 254 | 0 | 0 | 0 | 0 | 0 | 0 | 0 | 0 | 0 | 0 | 0 | 0 | 0 | 0 | 0 | 0 | 0 | 1 | 1 | 1 | 1 | 1 | 1 | 1 | 1 | 1 | | |
| | 255 | 0 | 0 | 0 | 0 | 0 | 0 | 0 | 0 | 0 | 0 | 0 | 0 | 0 | 0 | 0 | 0 | 1 | 1 | 1 | 1 | 1 | 1 | 1 | 1 | 1 | 1 | | |



3-6 Power Sequence for LCD Module

3.6.1 Power Sequence for LCD

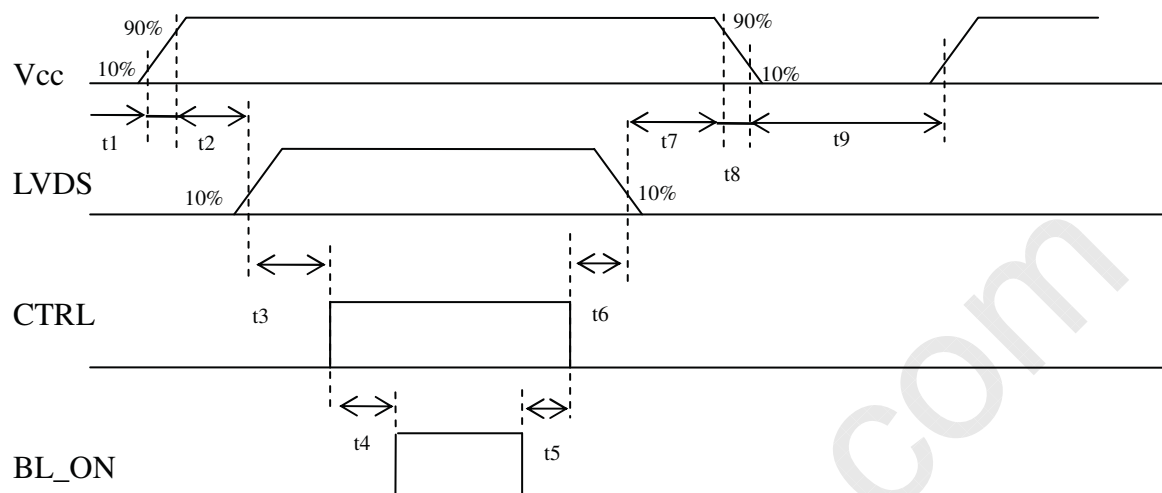

CTRL : T-BINT, SA_MODE, BUS_SW, PANEL_ON_RESET

| Parameter | Values | | | Units |
|-----------|--------|------|------|-------|
| | Min. | Typ. | Max. | |
| t1 | 0.47 | - | 5 | mS |
| t2 | 110 | - | 150 | mS |
| t3 | 10 | - | 20 | mS |
| t4 | 500 | - | - | mS |
| t5 | 200 | - | - | mS |
| t6 | 0 | - | - | mS |
| t7 | 0 | - | 50 | mS |
| t8 | 0.47 | - | 300 | mS |
| t9 | 1000 | - | - | mS |



3-7 Backlight Power Specification for LCD Module

3.7.1 Electrical specification

| Item | Symbol | | Condition | Spec | | | Unit | Note |
|------------------------------|------------|-----|-----------|------|---------|------|------|------|
| | | | | Min | Typical | Max | | |
| Input Voltage | V_{DDB} | | | 22.5 | 24 | 26.4 | VDC | |
| Input Current | I_{DDB} | | VDDB=24V | - | 6 | 6.35 | ADC | 1 |
| Input Power | P_{DDB} | | VDDB=24V | - | 140 | 147 | W | 1 |
| Inrush current | I_{RUSH} | | VDDB=24V | - | - | 8.5 | ADC | 2 |
| Output Frequency | F_{BL} | | VDDB=24V | 53 | 55 | 57 | KHz | |
| On/Off control voltage | V_{BLON} | ON | VDDB=24V | 2 | - | 5 | VDC | |
| | | OFF | | 0 | - | 0.8 | | |
| Dimming Control Voltage | V_{DIM} | MAX | VDDB=24V | 0 | - | 3.3 | VDC | |
| Internal Dimming Ratio | DIM_R | | | 20 | | 100 | % | |
| PWM control Voltage | V_{EPWM} | MAX | VDDB=24V | 2 | | 3.3 | VDC | |
| | | MIN | VDDB=24V | 0 | | 0.8 | | |
| External PWM control Current | I_{EPWM} | | VDDB=24V | | | 2 | mADC | |
| External PWM Duty ratio | D_{EPWM} | | VDDB=24V | 10 | | 100 | % | 3 |
| External PWM Frequency | F_{EPWM} | | VDDB=24V | 140 | 180 | 240 | Hz | |

Note 1 : VDIM= 3.3V (MAX)

(Ta=25±5°C , Turn on for 45minutes)

Note 2 : Measurement condition Rising time = 20 ms (VDDB : 10%~90%);

Note 3 : (a) Uniformity and flicker do not guarantee below 20% dimming control.

(b) 5% dimming control is function okay and no backlight shut down



3.7.2 Input Pin Assignment

CN2 : CI0114M1HRL-NH (Cvilux)

| Pin No | Symbol | Description |
|--------|--------------------|---|
| 1 | VDDDB (Main Power) | DV input 24.0 VDC |
| 2 | VDDDB (Main Power) | DV input 24.0 VDC |
| 3 | VDDDB (Main Power) | DV input 24.0 VDC |
| 4 | VDDDB (Main Power) | DV input 24.0 VDC |
| 5 | VDDDB (Main Power) | DV input 24.0 VDC |
| 6 | GND | Ground |
| 7 | GND | Ground |
| 8 | GND | Ground |
| 9 | GND | Ground |
| 10 | GND | Ground |
| 11 | DET Function | Panel status detect (Normal=0~0.8V, Abnormal=Open collector) |
| 12 | VBLON (Enable Pin) | BL On/Off control signal High/Open: On, Low: Off (Low=0~0.8V, High=2.0~5.0V) |
| 13 | VDIM | Internal PWM (3.3V, 100% duty) for 100% < NC ; when External PWM > |
| 14 | PDIM | External PWM input (AC 0~3.3V, Duty: 10%~100%) < NC ; when Internal PWM > |



3.7.3 Power Sequence for Inverter

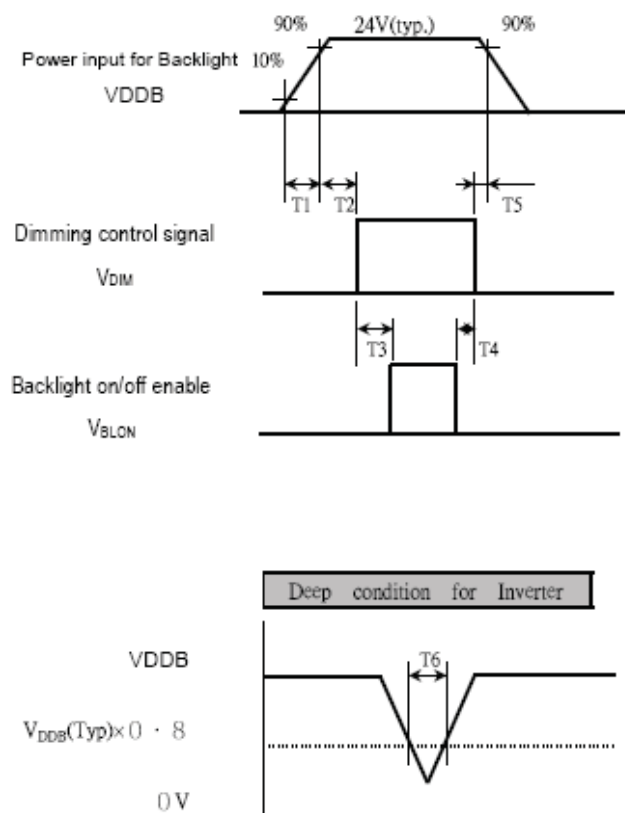

| Parameter | Values | | | Units |
|-----------|--------|------|------|-------|
| | Min. | Typ. | Max. | |
| T1 | 20 | - | - | ms |
| T2 | 50 | - | - | ms |
| T3 | 0 | - | - | ms |
| T4 | 0 | - | - | ms |
| T5 | 0 | - | - | ms |
| T6 | - | - | 10 | ms |





4. Optical Specification

Optical characteristics are determined after the unit has been 'ON' and stable for approximately 45 minutes in a dark environment at 25°C. The values specified are at an approximate distance 50cm from the LCD surface at a viewing angle of Φ and θ equal to 0°.

Fig.1 1 presents additional information concerning the measurement equipment and method.

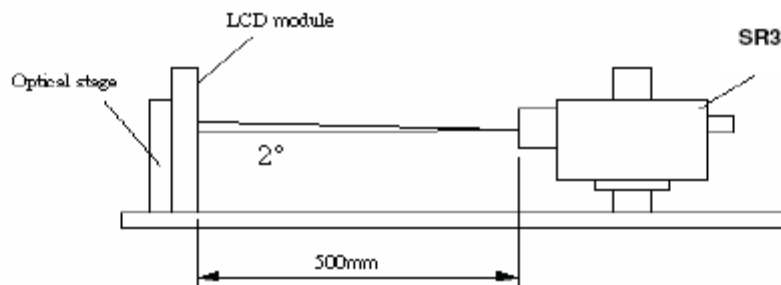

| Parameter | Symbol | Values | | | Units | Notes |
|-------------------------------------|-----------------------------|----------------|------|------|-------------------|-------|
| | | Min. | Typ. | Max. | | |
| Contrast Ratio | CR | 2000 | 2500 | | | 1 |
| Surface Luminance, white | LWH | 400 | 500 | | cd/m ² | 2 |
| Luminance Variation | δ_{WHITE} 9 p | | | 1.30 | | 3 |
| Response time G to G | T _γ | | 5.5 | 8 | ms | 4 |
| Color Gamut | NTSC | | 72 | | % | |
| Color Coordinates | | | | | | |
| | RED | R _x | 0.64 | | | |
| | | R _y | 0.33 | | | |
| | GREEN | G _x | 0.29 | | | |
| | | G _y | 0.60 | | | |
| | BLUE | B _x | 0.15 | | | |
| | | B _y | 0.06 | | | |
| | WHITE | W _x | 0.28 | | | |
| | | W _y | 0.29 | | | |
| Viewing Angle | | | | | | |
| x axis, right($\varphi=0^\circ$) | θ_r | | 89 | | degree | 5 |
| x axis, left($\varphi=180^\circ$) | θ_l | | 89 | | | |
| y axis, up($\varphi=90^\circ$) | θ_u | | 89 | | | |
| y axis, down ($\varphi=0^\circ$) | θ_d | | 89 | | | |



Note:

1. Contrast Ratio (CR) is defined mathematically as:

$$\text{Contrast Ratio} = \frac{\text{Surface Luminance of } L_{\text{on5}}}{\text{Surface Luminance of } L_{\text{off5}}}$$

2. Surface luminance is luminance value at point 5 across the LCD surface 50cm from the surface with all pixels displaying white. From more information see FIG 2. When $V_{\text{DDB}} = 24\text{V}$, $I_{\text{DDB}} = 5\text{A}$, $L_{\text{WH}} = L_{\text{on5}}$, where L_{on5} is the luminance with all pixels displaying white at center 5 location.
3. The variation in surface luminance, δ_{WHITE} is defined (center of Screen) as:
- $$\delta_{\text{WHITE(9P)}} = \text{Maximum}(L_{\text{on1}}, L_{\text{on2}}, \dots, L_{\text{on9}}) / \text{Minimum}(L_{\text{on1}}, L_{\text{on2}}, \dots, L_{\text{on9}})$$
4. Response time T_{γ} is the average time required for display transition by switching the input signal for five luminance ratio (0%, 25%, 50%, 75%, 100% brightness matrix) and is based on $f_v = 60\text{Hz}$ to optimize.

| | 0% | 25% | 50% | 75% | 100% |
|------|-----------|------------|------------|------------|------------|
| 0% | | t:0%-25% | t:0%-50% | t:0%-75% | t:0%-100% |
| 25% | t:25%-0% | | t:25%-50% | t:25%-75% | t:25%-100% |
| 50% | t:50%-0% | t:50%-25% | | t:50%-75% | t:50%-100% |
| 75% | t:75%-0% | t:75%-25% | t:75%-50% | | t:50%-100% |
| 100% | t:100%-0% | t:100%-25% | t:100%-50% | t:100%-75% | |

5. Viewing angle is the angle at which the contrast ratio is greater than 10. The angles are determined for the horizontal or x axis and the vertical or y axis with respect to the z axis which is normal to the LCD surface. For more information see FIG4.

FIG. 2 Luminance

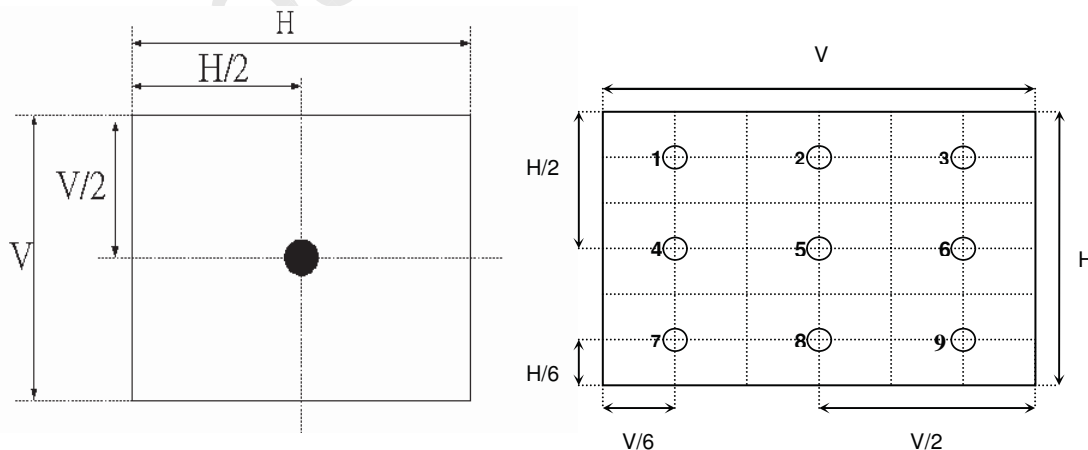



FIG.3 Response Time

The response time is defined as the following figure and shall be measured by switching the input signal for “any level of gray(bright) “ and “any level of gray(dark)”.

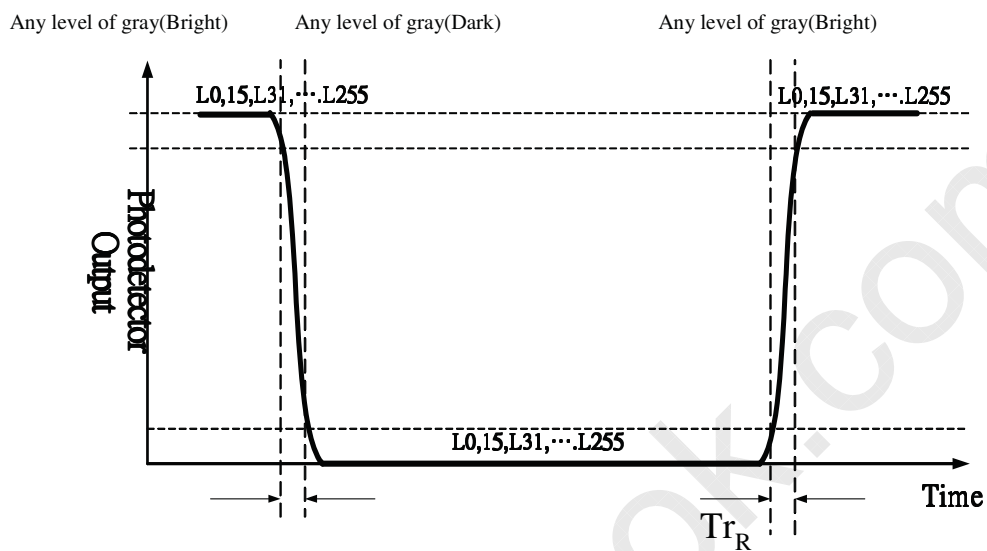
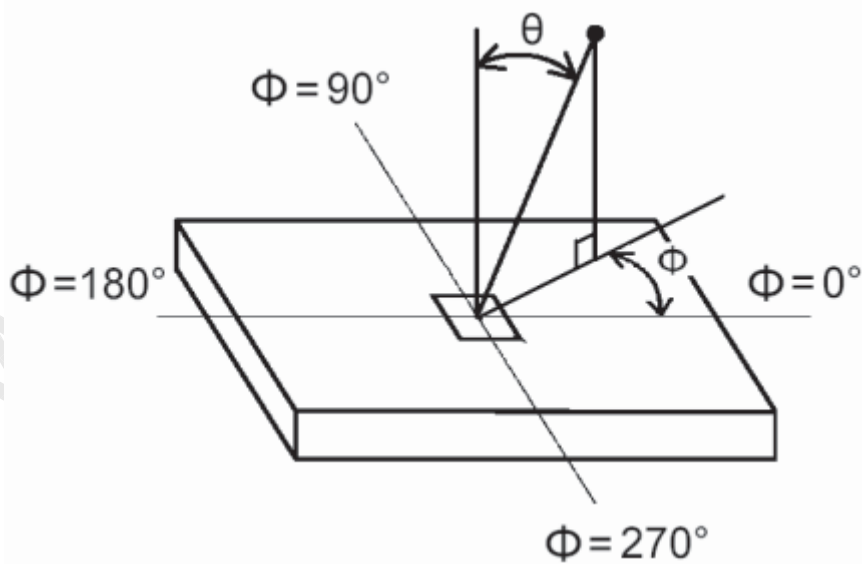

FIG.4 Viewing angle





5. Mechanical Characteristics

The contents provide general mechanical characteristics for the model T370HW02 VD. In addition the figures in the next page are detailed mechanical drawing of the LCD.

| | | |
|---------------------|---------------|------------------------|
| Outline Dimension | Horizontal | 877.0 mm |
| | Vertical | 514.6mm |
| | Depth | 54.3 mm(with inverter) |
| Bezel Opening | Horizontal | 827.8 mm |
| | Vertical | 469.4 mm |
| Active Display Area | Horizontal | 819.36 mm |
| | Vertical | 460.89 mm |
| Weight | 10000g (Typ.) | |

www.panelook.com



Mechanical Figure:

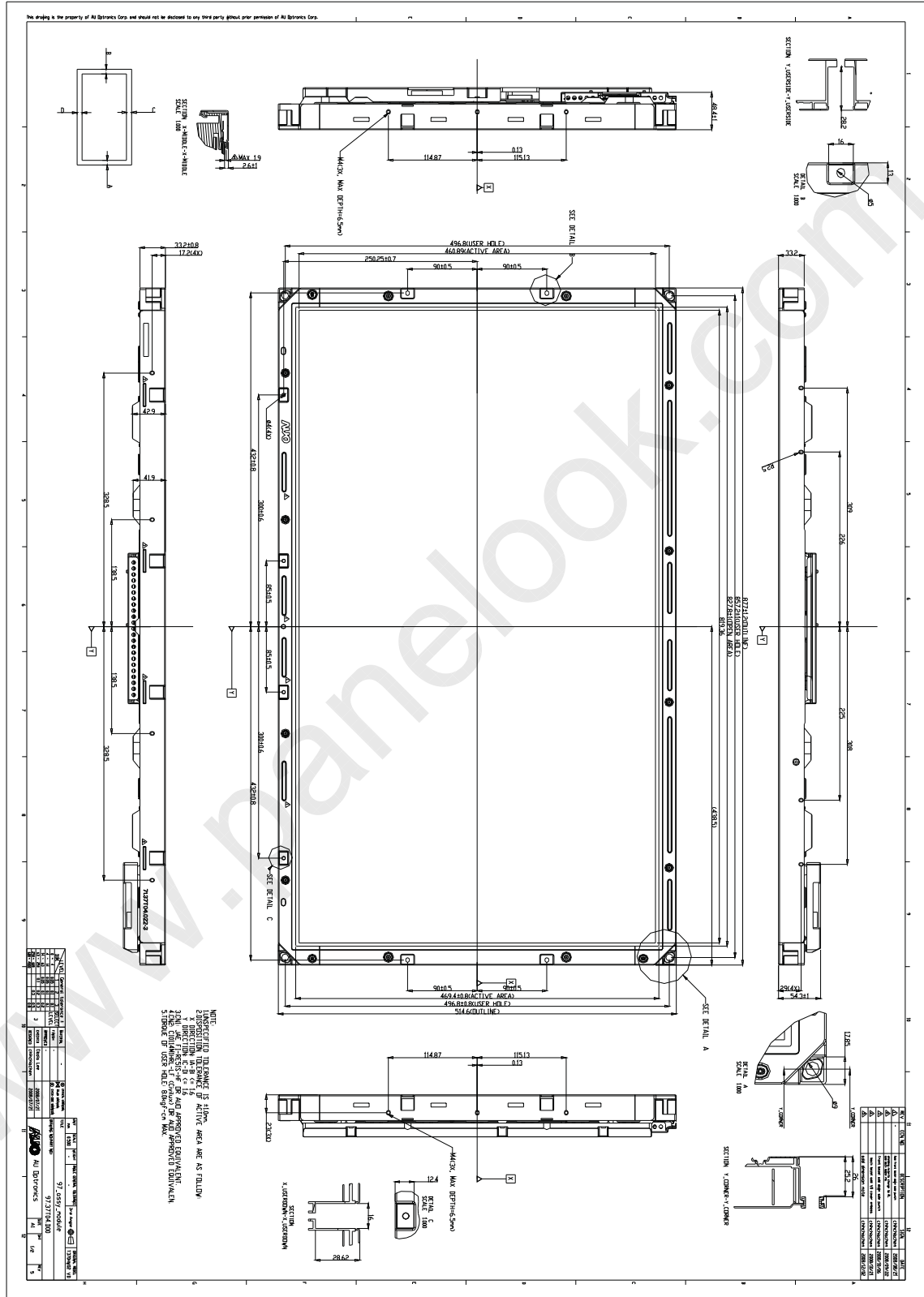

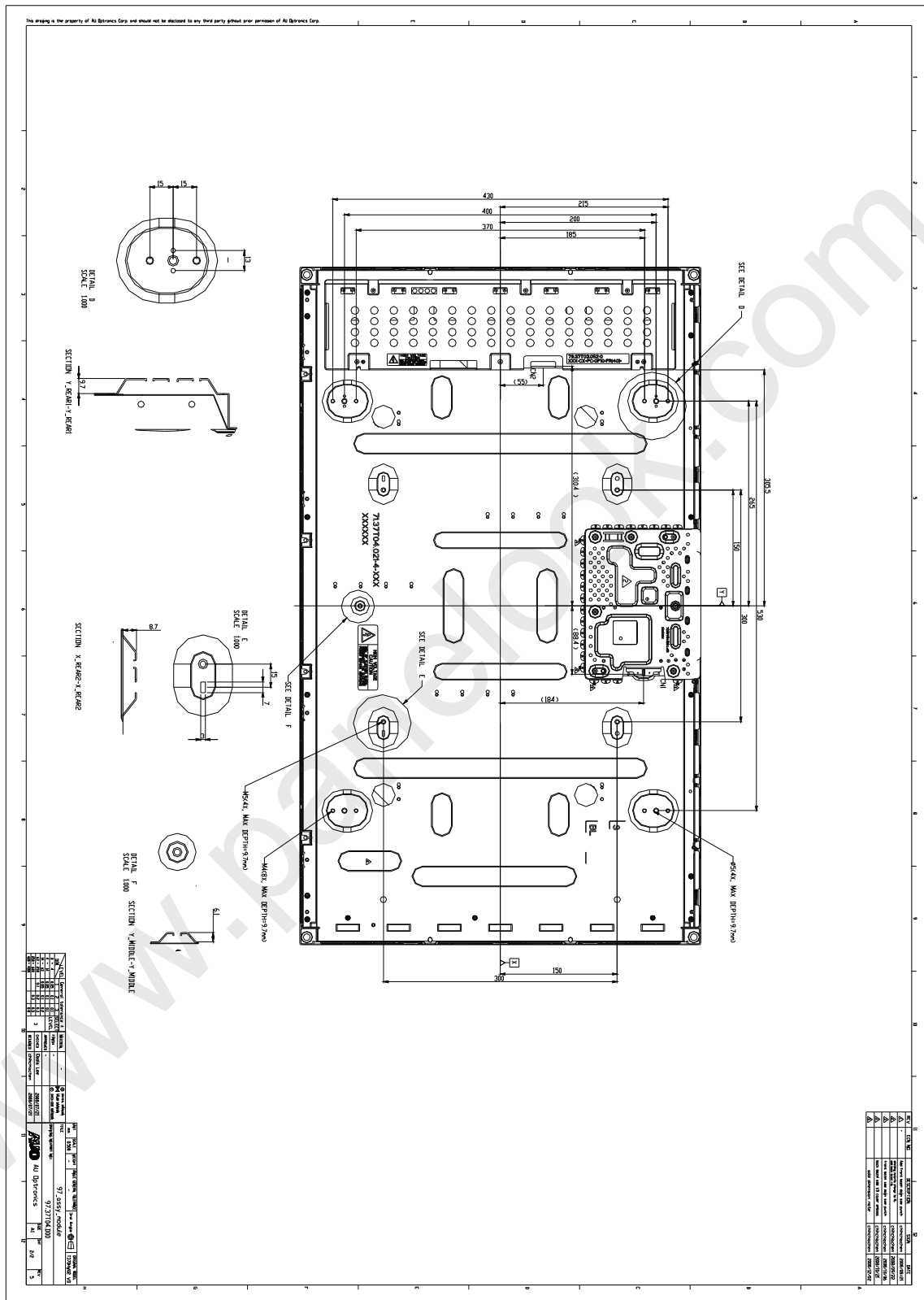



6. Reliability:

Environment test condition

| | Test Items | Q'ty | Conditions |
|---|----------------------------|------|--|
| 1 | High Temperature Stroage | 3 | 60°C 300 hrs |
| 2 | Low Temperature Stroage | 3 | -20°C, 300 hrs |
| 3 | High Temperature Operation | 3 | 50°C, 300 hrs |
| 4 | Low Temperature Operation | 3 | -5°C, 300 hrs |
| 5 | Vibration (non-operation) | 3 | (10 ~ 300Hz/1.5G/11min SR, XYZ 30min/axis) Vibration level : 1.5G RMS, Bandwidth : 10-300Hz Duration: X, Y, Z 30min, |
| 6 | Shock (non-operation) | 3 | Shock level: 50G Waveform: have sine wave, 11ms Direction: ±X,±Y, ±Z One time each direction |
| 7 | Vibration (With carton) | 3 | Random wave (1.5 Grms 10~200Hz) 30mins / Per each X.Y.Z axes |
| 8 | Drop (With carton) | 3 | Height: 38cm 1 corner, 3 edges, 6 surfaces (ASTMD4169-I) |



7. International Standard

7-1. Safety

- (1) UL1950 Third Edition, Underwriters Laboratories, Inc. Jan. 28, 1995

Standard for Safety of Information Technology Equipment Including electrical Business Equipment.

- (2) CAN/CSA C22.2 No. 950-95/60950 Third Edition, Canadian Standards Association,

Standard for Safety of Information Technology Equipment Including Electrical Business Equipment.

- (3) EN60950 : 1992+A2: 1993+A2: 1993+C3: 1995+A4: 1997+A11: 1997

IEC 950: 1991+A1: 1992+A2: 1993+C3: 1995+A4:1996

European Committee for Electrotechnical Standardization (CENELEC)

EUROPEAN STANDARD for Safety of Information Technology Equipment Including Electrical Business Equipment.

7-2. EMC

- a) ANSI C63.4 “Methods of Measurement of Radio-Noise Emissions from Low-Voltage Electrical and Electrical Equipment in the Range of 9kHz to 40GHz. “American National standards Institute(ANSI), 1992
- b) C.I.S.P.R “Limits and Methods of Measurement of Radio Interface Characteristics of Information Technology Equipment.” International Special committee on Radio Interference.
- c) EN 55022 “Limits and Methods of Measurement of Radio Interface Characteristics of Information Technology Equipment.” European Committee for Electrotechnical Standardization. (CENELEC), 1998



8. Packing

Panel label:



TW8800900028-ZM0200

TW88009: T: Taiwan, A/B: China

00028: Panel Serial Number

ZM0: AUO internal code

Manufactured 08/36: 2008 week 36

Made In Taiwan: Taiwan made

Carton Label:





Carton:

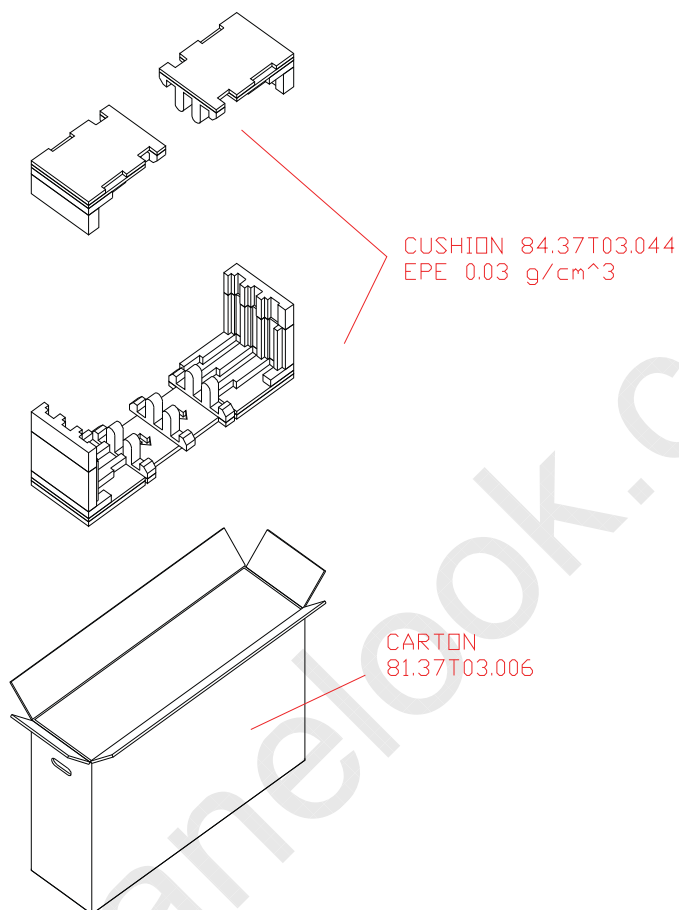

Pallet and Shipment information

| | Item | Specification | | | Packing |
|---|----------------------|--|---------------------------------------|--------------|---------|
| | | Qty. | Dimension | Weight (kg) | Remark |
| 1 | Packing BOX | 3 pcs/box | 965(L)mm*280(W)mm*610(H)mm | 30 | |
| 2 | Pallet | 1 | 1140(L)mm*980(W)mm*140(H)mm | 15 | |
| 3 | Boxes per Pallet | 8 boxes/Pallet (By Air) ; 12 Boxes/Pallet (By Sea) | | | |
| 4 | Panels per Pallet | 24pcs/pallet(By Air) ; 36 Boxes/Pallet (By Sea) | | | |
| | Pallet after packing | 24 (by Air) | 1140(L)mm*980(W)mm*1360(H)mm (by Air) | 257 (by Air) | |
| | | 36(by Sea) | 1140(L)mm*980(W)mm*2110(H)mm (by Sea) | 393 (by Sea) | |

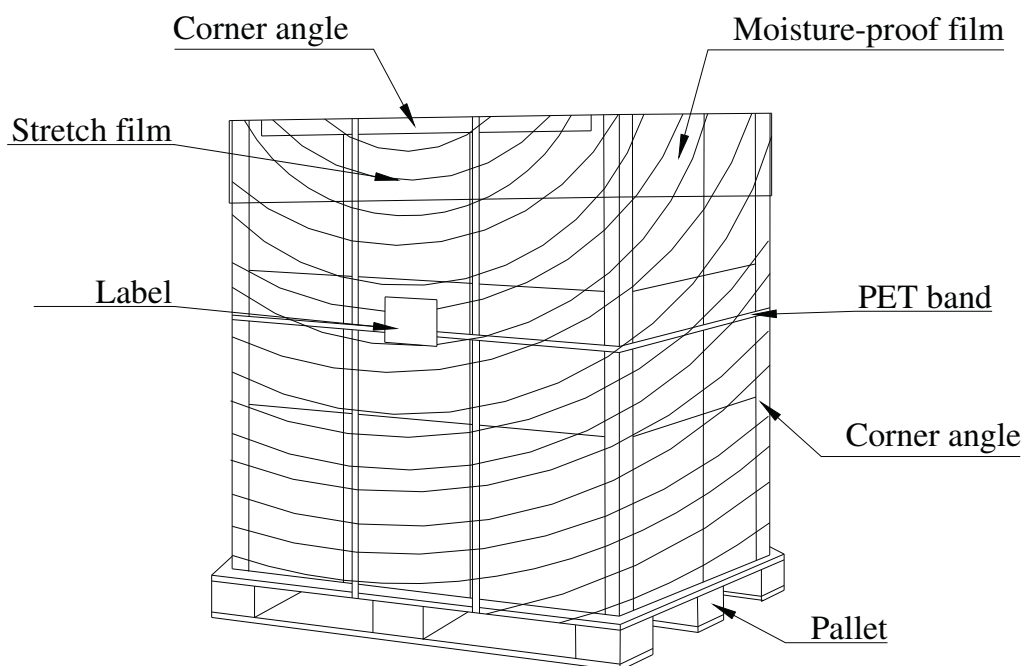

9. PRECAUTIONS

Please pay attention to the followings when you use this TFT LCD module.

9-1 MOUNTING PRECAUTIONS

- (1) You must mount a module using holes arranged in four corners or four sides.
- (2) You should consider the mounting structure so that uneven force (ex. Twisted stress) is not applied to module. And the case on which a module is mounted should have sufficient strength so that external force is not transmitted directly to the module.
- (3) Please attach the surface transparent protective plate to the surface in order to protect the polarizer. Transparent protective plate should have sufficient strength in order to resist external force.
- (4) You should adopt radiation structure to satisfy the temperature specification.
- (5) Acetic acid type and chlorine type materials for the cover case are not desirable because the former generates corrosive gas of attacking the polarizer at high temperature and the latter causes circuit break by electro-chemical reaction.
- (6) Do not touch, push or rub the exposed polarizers with glass, tweezers or anything harder than HB pencil lead. And please do not rub with dust clothes with chemical treatment. Do not touch the surface of polarizer for bare hand or greasy cloth. (Some cosmetics are detrimental to the polarizer.)
- (7) When the surface becomes dusty, please wipe gently with absorbent cotton or other soft materials like chamois soaks with petroleum benzene. Normal-hexane is recommended for cleaning the adhesives used to attach front/ rear polarizers. Do not use acetone, toluene and alcohol because they cause chemical damage to the polarizer.
- (8) Wipe off saliva or water drops as soon as possible. Their long time contact with polarizer causes deformations and color fading.
- (9) Do not open the case because inside circuits do not have sufficient strength.



9-2 OPERATING PRECAUTIONS

- (1) The device listed in the product specification sheets was designed and manufactured for TV application
- (2) The spike noise causes the mis-operation of circuits. It should be lower than following voltage:
 $V=\pm 200\text{mV}$ (Over and under shoot voltage)
- (3) Response time depends on the temperature. (In lower temperature, it becomes longer..)
- (4) Brightness depends on the temperature. (In lower temperature, it becomes lower.) And in lower temperature, response time (required time that brightness is stable after turned on) becomes longer.
- (5) Be careful for condensation at sudden temperature change. Condensation makes damage to polarizer or electrical contacted parts. And after fading condensation, smear or spot will occur.
- (6) When fixed patterns are displayed for a long time, remnant image is likely to occur.

Module has high frequency circuits. Sufficient suppression to the electromagnetic interference shall be done by system manufacturers. Grounding and shielding methods may be important to minimize the interface.

9-3 ELECTROSTATIC DISCHARGE CONTROL

Since a module is composed of electronic circuits, it is not strong to electrostatic discharge. Make certain that treatment persons are connected to ground through wrist band etc. And don't touch interface pin directly.

9-4 PRECAUTIONS FOR STRONG LIGHT EXPOSURE

Strong light exposure causes degradation of polarizer and color filter.

9-5 STORAGE+

When storing modules as spares for a long time, the following precautions are necessary.

- (1) Store them in a dark place. Do not expose the module to sunlight or fluorescent light. Keep the temperature between 5°C and 35°C at normal humidity.
- (2) The polarizer surface should not come in contact with any other object. It is recommended that they be stored in the container in which they were shipped.

9-6 HANDLING PRECAUTIONS FOR PROTECTION FILM

- (1) The protection film is attached to the bezel with a small masking tape. When the protection film is peeled off, static electricity is generated between the film and polarizer. This should be peeled off slowly and carefully by people who are electrically grounded and with well ion-blown equipment or in such a condition, etc.
- (2) When the module with protection film attached is stored for a long time, sometimes there remains a very small amount of glue still on the Bezel after the protection film is peeled off.
- (3) You can remove the glue easily. When the glue remains on the Bezel or its vestige is recognized, please wipe them off with absorbent cotton waste or other soft material like chamois soaked with normal-hexane.

Appendix - A

i. EMI specification

Model name: T37HW02 VD

| Item | Min | Typ | Max | Unit |
|------------------|-----|-----|-----|----------------|
| EMI level (Note) | --- | --- | -6 | dB(μ V/m) |
| SSCG | --- | 350 | --- | ps |

Note:

甲、Criteria: CISPR22

乙、Signal generator: PSG400 (Sony EMCS)

丙、EMI site: Sony EMCS Ichinomiya Tec. or using correlation value

丁、Find result should be checked by connecting with TV-set