

Document Version : 0.2

Date : 2008/12/25

Product Specifications

37" HDTV Color TFT-LCD Module

Model Name: T370HW02. VF

(*) Preliminary Specifications

() Final Specifications

Contents

No	
	CONTENTS
	RECORD OF REVISIONS
1	GENERAL DESCRIPTION
2	ABSOLUTE MAXIMUM RATINGS
3	ELECTRICAL SPECIFICATIONS
3-1	ELECTRICAL CHARACTERISTICS
3-2	INTERFACE CONNECTIONS
3-3	SIGNAL TIMING SPECIFICATIONS
3-4	SIGNAL TIMING WAVEFORMS
3-5	COLOR INPUT DATA REFERENCE
3-6	POWER SEQUENCE
3-7	BACKLIGHT POWER SPECIFICATION
4	OPTICAL SPECIFICATIONS
5	MECHANICAL CHARACTERISTICS
6	RELIABILITY
7	INTERNATIONAL STANDARDS
7-1	SAFETY
7-2	EMC
8	PACKING
9	PRECAUTIONS

1. General Description

This specification applies to the 37.0 inch Color TFT-LCD Module T370HW02 VF. This LCD module has a TFT active matrix type liquid crystal panel 1920*1080 pixels, and diagonal size of 37.0 inch. This module supports 1920*1080 HDTV mode (Non-interlace). Each pixel is divided into Red, Green and Blue sub-pixels or dots which are arranged in vertical stripes. Gray scale or the brightness of the sub-pixel color is determined with a 8-bit gray scale signal for each dot.

The T370HW02 VF has been designed to apply the 8-bit 2 channel LVDS interface method. It is intended to support displays where high brightness, wide viewing angle, high color saturation, and high color depth are very important.

The T370HW02 VF model is RoHS verified which can be distinguished on panel label.

* General Information

Items	Specification	Unit	Note
Active Screen Size	37.01	inch	
Display Area	819.36 (H) x 460.89(V)	mm	
Outline Dimension	877(H) x 516.8(V) x 55.3(D)	mm	With inverter
Driver Element	a-Si TFT active matrix		
Display Colors	8 bit, 16.7M	Colors	
Number of Pixels	1920 x 1080	Pixel	
Pixel Pitch	0.42675(H) x 0.42675(W)	mm	
Pixel Arrangement	RGB vertical stripe		
Display Operation Mode	Normally Black		
Surface Treatment	Anti-Glare, 3H		Haze = 11

2. Absolute Maximum Ratings

The following are maximum values which, if exceeded, may cause permanent damage to the unit.

Item	Symbol	Min	Max	Unit	Conditions
Logic/LCD Drive Voltage	Vcc	-0.3	14	[Volt]	Note 1
Input Voltage of Signal	Vin	-0.3	3.6	[Volt]	Note 1
BLU Input Voltage	VDDDB	-0.3	28	[Volt]	Note 1
BLU Brightness Control Voltage	Vdim	-0.3	7.0	[Volt]	Note 1
Operating Temperature	TOP	0	+50	[°C]	Note 2
Operating Humidity	HOP	10	90	[%RH]	Note 2
Storage Temperature	TST	-20	+60	[°C]	Note 2
Storage Humidity	HST	10	90	[%RH]	Note 2
Panel Surface Temperature	PST		65	[°C]	Note 3

Note 1: Duration:50 msec.

Note 2 : Maximum Wet-Bulb should be 39°C and No condensation.

The relative humidity must not exceed 90% non-condensing at temperatures of 40°C or less. At temperatures greater than 40°C, the wet bulb temperature must not exceed 39°C.

Note 3: Surface temperature is measured at 50°C Dry condition

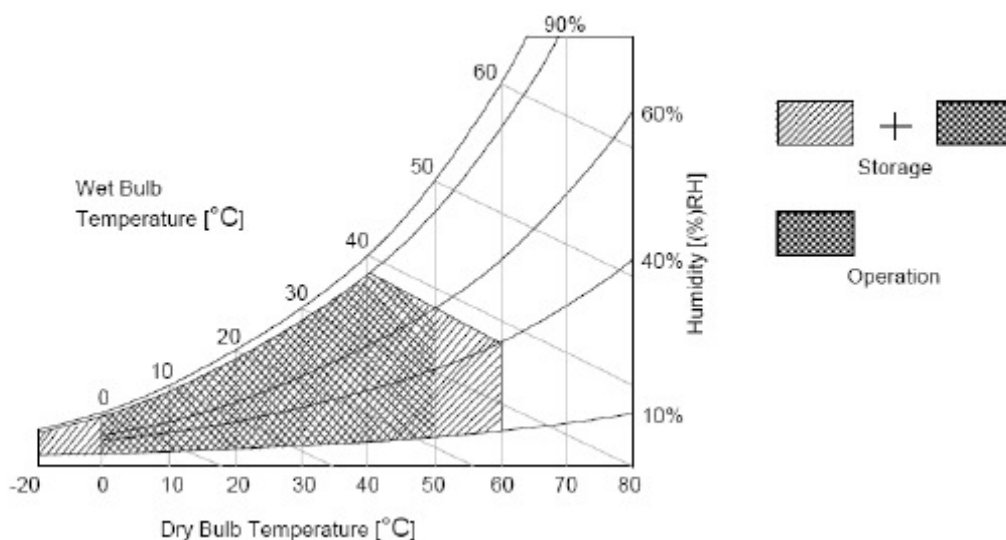

3. Electrical Specification

The T370HW02 VF requires two power inputs. One is employed to power the LCD electronics and to drive the TFT array and liquid crystal. The second input power for the BLU, is to power inverter. (INV)

3-1 Electrical Characteristics

Parameter			Values			Unit	Notes
			Min	Typ	Max		
LCD:							
Power Supply Input Voltage		Vcc	10.8	12	13.2	Vdc	1
Power Supply Input Current		Icc	-	1	1.2	A	2
Power Consumption		Pc	-	12	14.4	Watt	2
Inrush Current		I _{RUSH}	-	-	4	Apeak	3
LVDS Interface	Differential Input High Threshold Voltage	VTH			100	mV	4
	Differential Input Low Threshold Voltage	VTL	-100			mV	4
	Common Input Voltage	VCIM	1.10	1.25	1.40	V	4
CMOS Interface	Input High Threshold Voltage	V _{IH} (High)	2.4		3.3	Vdc	
	Input Low Threshold Voltage	V _{IL} (Low)	0		0.9	Vdc	
Backlight Power Consumption		P _{DDDB}		90		Watt	
Life Time			50,000			Hours	

Note :

1. The ripple voltage should be controlled under 10% of V_{CC}
2. V_{cc}=12.0V, $f_v = 60\text{Hz}$, $f_{\text{CLK}}=81.5\text{Mhz}$, 25°C, Test Pattern : White Pattern
3. Measurement condition :

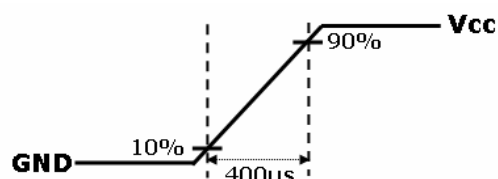

4. $V_{CIM} = 1.2V$

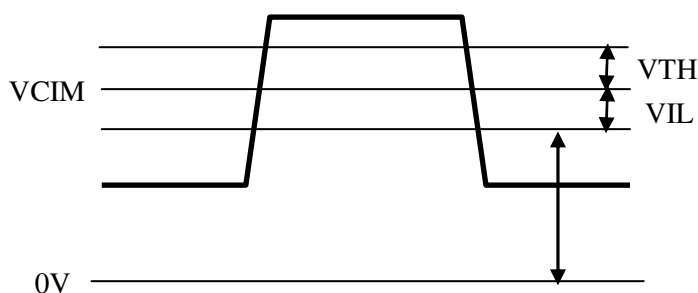

5. The performance of the Lamp in LCD panel, for example life time or brightness, is extremely influenced by the characteristics of the DC-AC Inverter. So all the parameters of an inverter should be carefully designed as not to produce too much leakage current from high-voltage output of the inverter. When you design or order the inverter, please make sure unwanted lighting caused by the mismatch of the lamp and the inverter (no lighting, flicker, etc) never occurs. After confirmation, the LCD panel should be operated in the same condition as installed in your instrument.
6. Do not attach a conducting tape to lamp connecting wire. If the lamp wire attach to conducting tape, TFT-LCD Module have a low luminance and the inverter has abnormal action because leakage current occurs between lamp wire and conducting tape.
7. The relative humidity must not exceed 80% non-condensing at temperatures of $40^{\circ}C$ or less. At temperatures greater than $40^{\circ}C$, the wet bulb temperature must not exceed $39^{\circ}C$. When operate at low temperatures, the brightness of CCFL will drop and the life time of CCFL will be reduced.
8. Specified values are for a single lamp only which is aligned horizontally. The lifetime is defined as the time which luminance of the lamp is 50% compared to its original value.

[Operating condition: Continuous operating at $T_a = 25 \pm 2^{\circ}C$]

3-2 Interface Connections

LCD connector (CN1): JAE FI-RE51S-HF

Pin No	Symbol	Description	Note
1	NC	No Connect (AUO internal use)	
2	NC	No Connect (AUO internal use)	
3	NC	No Connect (AUO internal use)	
4	NC	No Connect (AUO internal use)	
5	NC	No Connect (AUO internal use)	
6	NC	No Connect (AUO internal use)	
7	LVDS Option	Low/Open for Normal (NS), High for JEIDA	Default : NS mode
8	NC	No Connect (AUO internal use)	
9	NC	No Connect (AUO internal use)	
10	NC	No Connect (AUO internal use)	
11	GND	Ground	
12	R1_0-	LVDS Channel 1, Signal 0-	Channel 1
13	R1_0+	LVDS Channel 1, Signal 0+	
14	R1_1-	LVDS Channel 1, Signal 1-	
15	R1_1+	LVDS Channel 1, Signal 1+	
16	R1_2-	LVDS Channel 1, Signal 2-	
17	R1_2+	LVDS Channel 1, Signal 2+	
18	GND	Ground	
19	R1_CLK-	LVDS Channel 1, Clock -	
20	R1_CLK+	LVDS Channel 1, Clock +	
21	GND	Ground	
22	R1_3-	LVDS Channel 1, Signal 3-	
23	R1_3+	LVDS Channel 1, Signal 3+	
24	R1_4-	LVDS Channel 1, Signal 4-	
25	R1_4+	LVDS Channel 1, Signal 4+	
26	NC or GND	No Connect or Ground	
27	NC or GND	No Connect or Ground	
28	R2_0-	LVDS Channel 2, Signal 0-	Channel 2
29	R2_0+	LVDS Channel 2, Signal 0+	
30	R2_1-	LVDS Channel 2, Signal 1-	
31	R2_1+	LVDS Channel 2, Signal 1+	
32	R2_2-	LVDS Channel 2, Signal 2-	

33	R2_2+	LVDS Channel 2, Signal 2+	Power
34	GND	Ground	
35	R2_CLK-	LVDS Channel 2, Clock -	
36	R2_CLK+	LVDS Channel 2, Clock +	
37	GND	Ground	
38	R2_3-	LVDS Channel 2, Signal 3-	
39	R2_3+	LVDS Channel 2, Signal 3+	
40	R2_4-	LVDS Channel 2, Signal 4-	
41	R2_4+	LVDS Channel 2, Signal 4+	
42	NC or GND	No Connect or Ground	
43	NC or GND	No Connect or Ground	
44	GND	Ground	
45	GND	Ground	
46	GND	Ground	
47	V _{DD}	Operating Voltage supply, +12V DC regulated	
48	V _{DD}	Operating Voltage supply, +12V DC regulated	
49	V _{DD}	Operating Voltage supply, +12V DC regulated	
50	V _{DD}	Operating Voltage supply, +12V DC regulated	
51	V _{DD}	Operating Voltage supply, +12V DC regulated	

LCD connector (CN2):JAE FI-RE41S-HF

Pin No	Symbol	Description	Note
1	NC	No Connect (AUO internal use)	
2	NC	No Connect (AUO internal use)	
3	NC	No Connect (AUO internal use)	
4	NC	No Connect (AUO internal use)	
5	NC	No Connect (AUO internal use)	
6	NC	No Connect (AUO internal use)	
7	NC	No Connect (AUO internal use)	
8	NC	No Connect (AUO internal use)	
9	GND	Ground	
10	R3_0-	LVDS Channel 3, Signal 0-	Channel 3
11	R3_0+	LVDS Channel 3, Signal 0+	
12	R3_1-	LVDS Channel 3, Signal 1-	
13	R3_1+	LVDS Channel 3, Signal 1+	
14	R3_2-	LVDS Channel 3, Signal 2-	

15	R3_2+	LVDS Channel 3, Signal 2+	Channel 4
16	GND	Ground	
17	R3_CLK-	LVDS Channel 3, Clock -	
18	R3_CLK+	LVDS Channel 3, Clock +	
19	GND	Ground	
20	R3_3-	LVDS Channel 3, Signal 3-	
21	R3_3+	LVDS Channel 3, Signal 3+	
22	R3_4-	LVDS Channel 3, Signal 4-	
23	R3_4+	LVDS Channel 3, Signal 4+	
24	NC or GND	No Connect or Ground	
25	NC or GND	No Connect or Ground	
26	R4_0-	LVDS Channel 4, Signal 0-	
27	R4_0+	LVDS Channel 4, Signal 0+	
28	R4_1-	LVDS Channel 4, Signal 1-	
29	R4_1+	LVDS Channel 4, Signal 1+	
30	R4_2-	LVDS Channel 4, Signal 2-	
31	R4_2+	LVDS Channel 4, Signal 2+	
32	GND	Ground	
33	R4_CLK-	LVDS Channel 4, Clock -	
34	R4_CLK+	LVDS Channel 4, Clock +	
35	GND	Ground	
36	R4_3-	LVDS Channel 4, Signal 3-	
37	R4_3+	LVDS Channel 4, Signal 3+	
38	R4_4-	LVDS Channel 4, Signal 4-	
39	R4_4+	LVDS Channel 4, Signal 4+	
40	NC or GND	No Connect or Ground	
41	NC or GND	No Connect or Ground	

Note:

1. All GND (ground) pins should be connected together and should also be connected to the LCD's metal frame. All Vcc (power input) pins should be connected together.
2. For Pin 10, 27 and 28, panel will not damage if negligently connect these pins to high or low

Open/low: NS

NS-Like Format

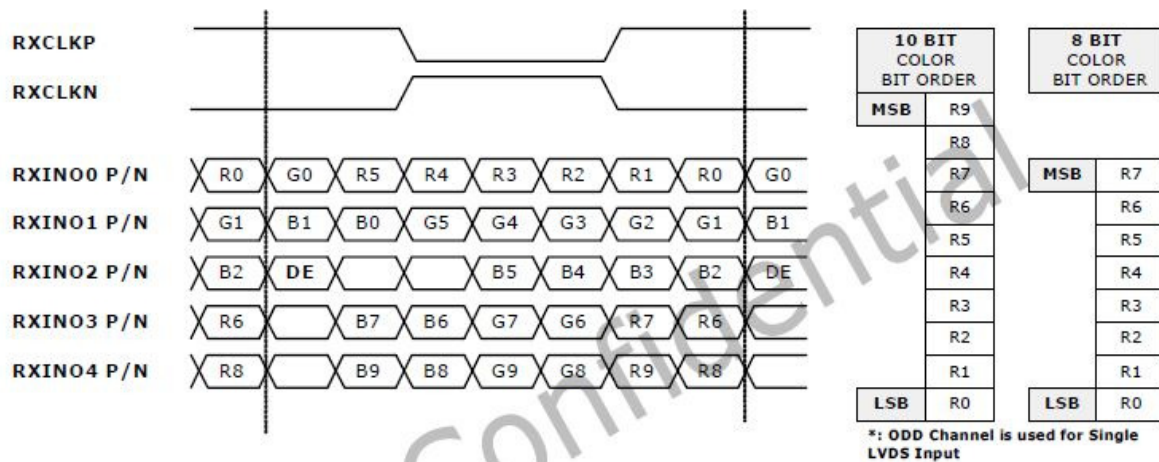

1 LVDS Data Mapping of NS-Like Format for Single Channel

High: JEIDA

JEIDA Format

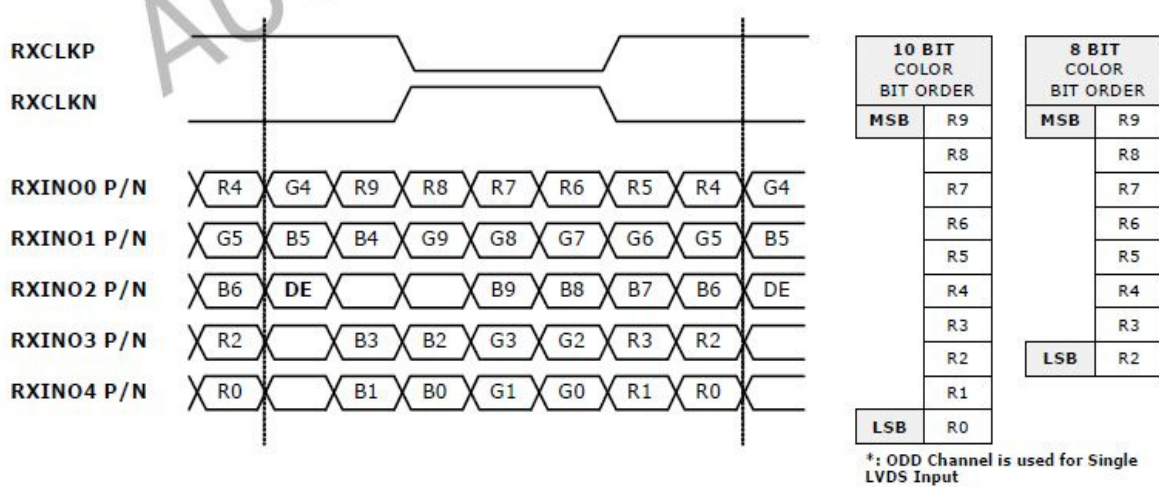

2 LVDS Data Mapping of JEIDA Format for Single Channel

3-3 Signal Timing Specifications

This is the signal timing required at the input of the User connector. All of the interface signal timing should be satisfied with the following specifications for its proper operation.

* Timing Table

DE only Mode (120Hz)

Signal	Item	Symbol	Min	Type	Max	Unit
Vertical Section	Period	Tv	1096	1130	1160	Th
	Active	Tdisp (v)	1080			Th
	Blanking	Tblk (v)	16	50	80	Th
Horizontal Section	Period	Th	560	570	580	Tclk
	Active	Tdisp (h)	480			Tclk
	Blanking	Tblk (h)	80	90	100	Tclk
Clock	Frequency	1/Tclk	73.65	77.29	80.74	MHz
Vertical Frequency	Frequency	Freq	118	120	122	Hz
Horizontal Frequency	Frequency	Freq	131.52	135.6	139.2	KHz

DE only Mode (100Hz)

Signal	Item	Symbol	Min	Type	Max	Unit
Vertical Section	Period	Tv	1200	1280	1392	Th
	Active	Tdisp (v)	1080			Th
	Blanking	Tblk (v)	120	200	312	Th
Horizontal Section	Period	Th	560	570	580	Tclk
	Active	Tdisp (h)	480			Tclk
	Blanking	Tblk (h)	80	90	100	Tclk
Clock	Frequency	1/Tclk	67.2	72.96	80.74	MHz
Vertical Frequency	Frequency	Freq	96 ¹	100	102	Hz
Horizontal Frequency	Frequency	Freq	120	128	139.2	KHz

Notes:

1.) Display position is specific by the rise of DE signal only.

Horizontal display position is specified by the rising edge of 1st DCLK after the rise of 1st DE, is displayed on the left edge of the screen.

Vertical display position is specified by the rise of DE after a "Low" level period equivalent to eight times of horizontal period. The 1st data corresponding to one horizontal line after the rise the of 1st DE is displayed at the top line of screen.

3.) If a period of DEB "High" is less than 1920 DCLK or less than 1080 lines, the rest of the screen displays black.

4.) The display position does not fit to the screen if a period of DE "High" and the effective data period do not synchronize with each other.

3-4 Signal Timing Waveforms

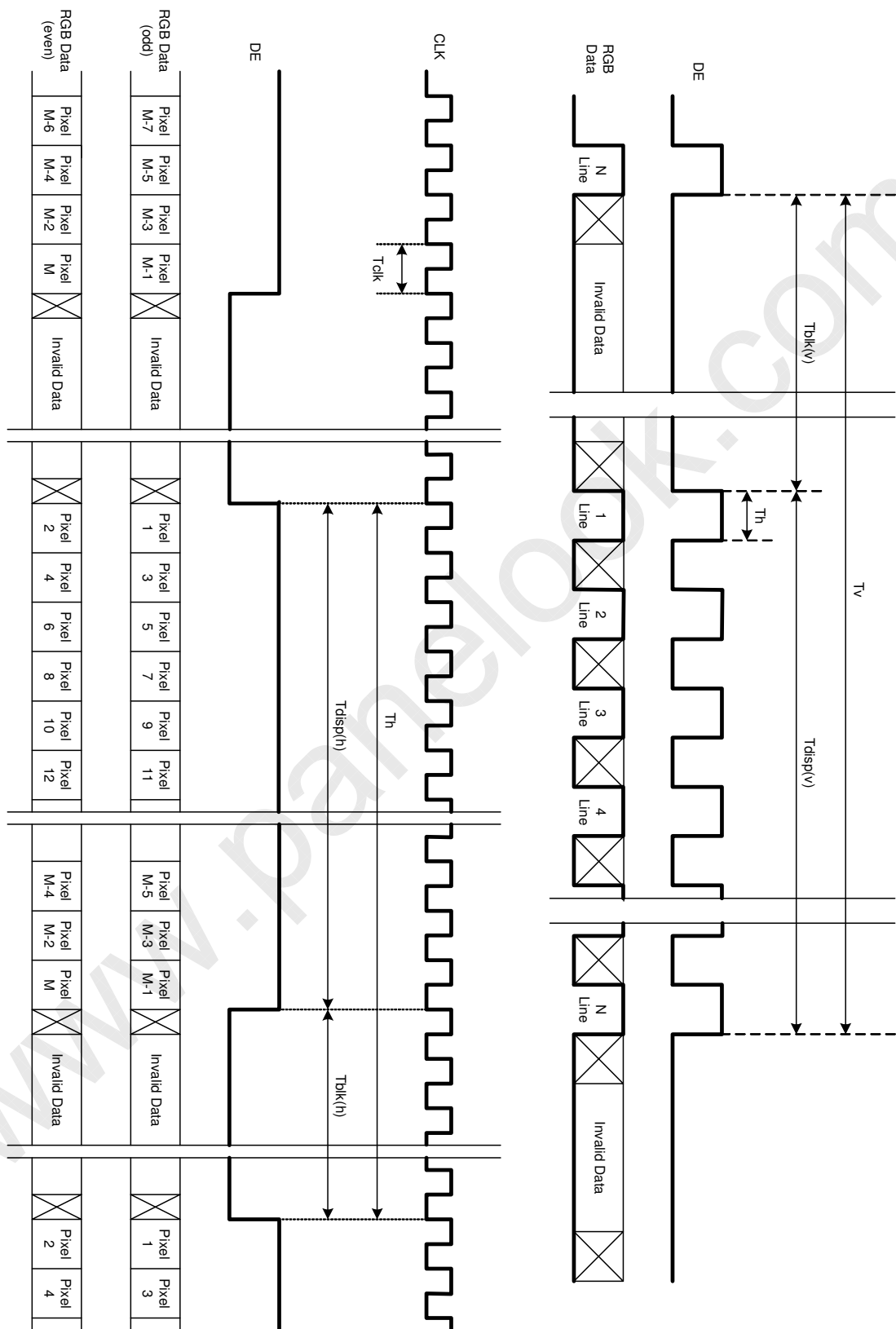

3-5 Color Input Data Reference

The brightness of each primary color (red, green and blue) is based on the 8 bit gray scale data input for the color; the higher the binary input, the brighter the color. The table below provides a reference for color versus data input.

COLOR DATA REFERENCE

Color		Input Color Data																							
		RED								GREEN								BLUE							
		MSB				LSB				MSB				LSB				MSB				LSB			
		R7	R6	R5	R4	R3	R2	R1	R0	G7	G6	G5	G4	G3	G2	G1	G0	B7	B6	B5	B4	B3	B2	B1	B0
Basic Color	Black	0	0	0	0	0	0	0	0	0	0	0	0	0	0	0	0	0	0	0	0	0	0	0	0
	Red(255)	1	1	1	1	1	1	1	1	0	0	0	0	0	0	0	0	0	0	0	0	0	0	0	0
	Green(255)	0	0	0	0	0	0	0	0	1	1	1	1	1	1	1	1	0	0	0	0	0	0	0	0
	Blue(255)	0	0	0	0	0	0	0	0	0	0	0	0	0	0	0	0	1	1	1	1	1	1	1	1
	Cyan	0	0	0	0	0	0	0	0	1	1	1	1	1	1	1	1	1	1	1	1	1	1	1	1
	Magenta	1	1	1	1	1	1	1	1	0	0	0	0	0	0	0	0	1	1	1	1	1	1	1	1
	Yellow	1	1	1	1	1	1	1	1	1	1	1	1	1	1	1	1	0	0	0	0	0	0	0	0
	White	1	1	1	1	1	1	1	1	1	1	1	1	1	1	1	1	1	1	1	1	1	1	1	1
RED	RED(000)	0	0	0	0	0	0	0	0	0	0	0	0	0	0	0	0	0	0	0	0	0	0	0	0
	RED(001)	0	0	0	0	0	0	0	1	0	0	0	0	0	0	0	0	0	0	0	0	0	0	0	0

	RED(254)	1	1	1	1	1	1	1	0	0	0	0	0	0	0	0	0	0	0	0	0	0	0	0	0
	RED(255)	1	1	1	1	1	1	1	1	0	0	0	0	0	0	0	0	0	0	0	0	0	0	0	0
GREEN	GREEN(000)	0	0	0	0	0	0	0	0	0	0	0	0	0	0	0	0	0	0	0	0	0	0	0	0
	GREEN(001)	0	0	0	0	0	0	0	0	0	0	0	0	0	0	0	1	0	0	0	0	0	0	0	0

	GREEN(254)	0	0	0	0	0	0	0	0	1	1	1	1	1	1	1	0	0	0	0	0	0	0	0	0
	GREEN(255)	0	0	0	0	0	0	0	0	1	1	1	1	1	1	1	1	0	0	0	0	0	0	0	0
BLUE	BLUE(000)	0	0	0	0	0	0	0	0	0	0	0	0	0	0	0	0	0	0	0	0	0	0	0	0
	BLUE(001)	0	0	0	0	0	0	0	0	0	0	0	0	0	0	0	0	0	0	0	0	0	0	0	1

	BLUE(254)	0	0	0	0	0	0	0	0	0	0	0	0	0	0	0	0	1	1	1	1	1	1	1	0
	BLUE(255)	0	0	0	0	0	0	0	0	0	0	0	0	0	0	0	0	1	1	1	1	1	1	1	1



3-6 Power Sequence for LCD Module

3.6.1 Power Sequence for LCD

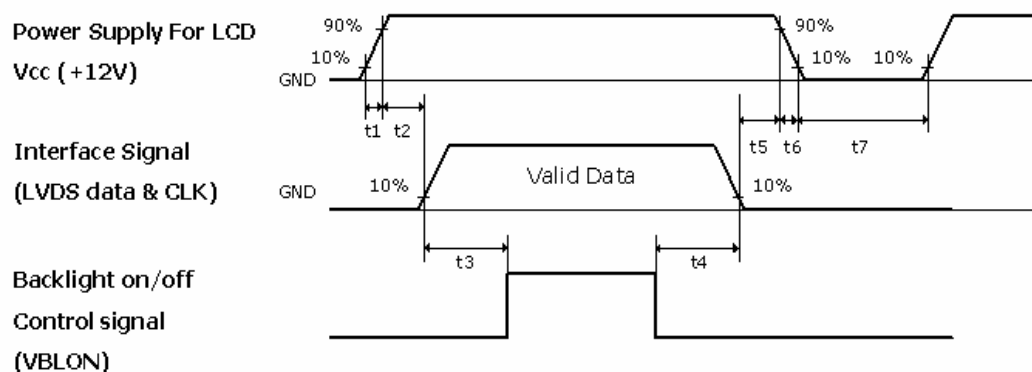

Parameter	Value			Units
	Min.	Typ.	Max.	
T1	0.4	---	30	ms
T2	0.1	---	50	ms
T3	300	---	---	ms
T4	10	---	---	ms
T5	0.1	---	50	ms
T6	---	---	300	ms
T7	500	---	---	ms

Note:

The timing controller will not be damaged in case of TV set AC input power suddenly shut down.

Once power reset, it should follow power sequence as spec. definition.

- (1) Apply the lamp voltage within the LCD operation range. When the back-light turns on before the LCD operation or the LCD turns off before the back-light turns off, the display may momentarily become abnormal screen.



3-7 Backlight Power Specification for LCD Module

3.7.1 Electrical specification

Item	Symbol		Condition	Spec			Unit	Note
				Min	Typical	Max		
Input Voltage	V _{DDB}			21.6	24	26.4	VDC	
Input Current	I _{DDB}		V _{DDB} =24V	-	3.75		ADC	1
Input Power	P _{DDB}		V _{DDB} =24V	-	90		W	1
Inrush current	I _{RUSH}		V _{DDB} =24V	-	-	8.5	ADC	2
Output Frequency	F _{BL}		V _{DDB} =24V	42	44	46	KHz	
On/Off control voltage	V _{BLON}	ON	V _{DDB} =24V	2	-	5	VDC	
		OFF		0	-	0.8		
Dimming Control Voltage	V _{DIM}	MAX	V _{DDB} =24V	0	-	3.3	VDC	
Internal Dimming Ratio	DIM_R			20		100	%	
PWM control Voltage	V _{EPWM}	MAX	V _{DDB} =24V	2		3.3	VDC	
		MIN	V _{DDB} =24V	0		0.8		
External PWM control Current	I _{EPWM}		V _{DDB} =24V			2	mADC	
External PWM Duty ratio	D _{EPWM}		V _{DDB} =24V	10		100	%	3
External PWM Frequency	F _{EPWM}		V _{DDB} =24V	140	180	240	Hz	

Note 1 : VD_{DIM}= 3.3V (MAX)

(Ta=25±5°C, Turn on for 45minutes)

Note 2 : Measurement condition Rising time = 20 ms (V_{DDB} : 10%~90%);

Note 3 : (a) Uniformity and flicker do not guarantee below 20% dimming control.

(b) 10% dimming control is function okay and no backlight shut down



3.7.2 Input Pin Assignment

CN3:CI0114M1HRL-NH (Civilux)

Pin No	Symbol	Description
1	VDDDB (Main Power)	DV input 24.0 VDC
2	VDDDB (Main Power)	DV input 24.0 VDC
3	VDDDB (Main Power)	DV input 24.0 VDC
4	VDDDB (Main Power)	DV input 24.0 VDC
5	VDDDB (Main Power)	DV input 24.0 VDC
6	GND	Ground
7	GND	Ground
8	GND	Ground
9	GND	Ground
10	GND	Ground
11	DET Function	Panel status detect (Normal=0~0.8V, Abnormal=Open collector)
12	VBLON (Enable Pin)	BL On/Off control signal High/Open: On, Low: Off (Low=0~0.8V, High=2.0~5.0V)
13	VDIM	Internal PWM (3.3V, 100% duty) for 100% < NC ; when External PWM >
14	PDIM	External PWM input (AC 0~3.3V, Duty: 10%~100%) < NC ; when Internal PWM >



3.7.3 Power Sequence for Inverter

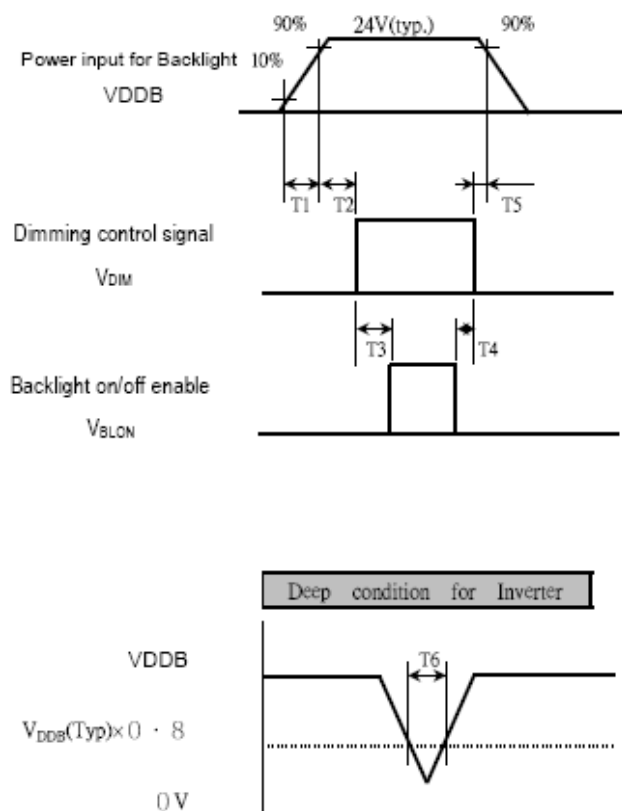

Parameter	Values			Units
	Min.	Typ.	Max.	
T1	20	-	-	ms
T2	50	-	-	ms
T3	0	-	-	ms
T4	0	-	-	ms
T5	0	-	-	ms
T6	-	-	10	ms



4. Optical Specification

Optical characteristics are determined after the unit has been 'ON' and stable for approximately 45 minutes in a dark environment at 25°C. The values specified are at an approximate distance 50cm from the LCD surface at a viewing angle of Φ and θ equal to 0°.

Fig.1 1 presents additional information concerning the measurement equipment and method.

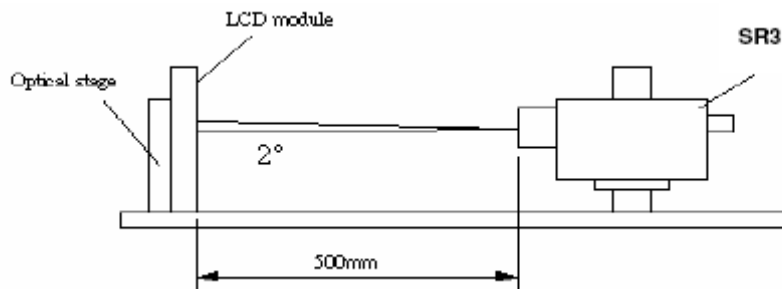

Parameter	Symbol	Values			Units	Notes
		Min.	Typ.	Max.		
Contrast Ratio	CR	2000	3000			1
Surface Luminance, white	LWH	400	500		cd/m ²	2
Luminance Variation	δ_{WHITE} 9 p			1.30		3
Response time G to G	T γ		5.5	8	ms	4
Color Gamut	NTSC		72		%	
Color Coordinates						
	RED	R _X	0.64			
		R _Y	0.33			
	GREEN	G _X	0.29			
		G _Y	0.60			
	BLUE	B _X	0.15			
		B _Y	0.06			
	WHITE	W _X	0.28			
		W _Y	0.29			
Viewing Angle						
x axis, right($\varphi=0^\circ$)	θ_r		89		degree	5
x axis, left($\varphi=180^\circ$)	θ_l		89			
y axis, up($\varphi=90^\circ$)	θ_u		89			
y axis, down ($\varphi=0^\circ$)	θ_d		89			



Note:

1. Contrast Ratio (CR) is defined mathematically as:

$$\text{Contrast Ratio} = \frac{\text{Surface Luminance of } L_{\text{on5}}}{\text{Surface Luminance of } L_{\text{off5}}}$$

2. Surface luminance is luminance value at point 5 across the LCD surface 50cm from the surface with all pixels displaying white. From more information see FIG 2. When $V_{\text{DDB}} = 24\text{V}$, $I_{\text{DDB}} = 5\text{A}$, $L_{\text{WH}} = L_{\text{on5}}$, where L_{on5} is the luminance with all pixels displaying white at center 5 location.
3. The variation in surface luminance, δ_{WHITE} is defined (center of Screen) as:
- $$\delta_{\text{WHITE(9P)}} = \frac{\text{Maximum}(L_{\text{on1}}, L_{\text{on2}}, \dots, L_{\text{on9}})}{\text{Minimum}(L_{\text{on1}}, L_{\text{on2}}, \dots, L_{\text{on9}})}$$
4. Response time T_{γ} is the average time required for display transition by switching the input signal for five luminance ratio (0%,25%,50%,75%,100% brightness matrix) and is based on $f_v = 60\text{Hz}$ to optimize.

	0%	25%	50%	75%	100%
0%		t:0%-25%	t:0%-50%	t:0%-75%	t:0%-100%
25%	t:25%-0%		t:25%-50%	t:25%-75%	t:25%-100%
50%	t:50%-0%	t:50%-25%		t:50%-75%	t:50%-100%
75%	t:75%-0%	t:75%-25%	t:75%-50%		t:50%-100%
100%	t:100%-0%	t:100%-25%	t:100%-50%	t:100%-75%	

5. Viewing angle is the angle at which the contrast ratio is greater than 10. The angles are determined for the horizontal or x axis and the vertical or y axis with respect to the z axis which is normal to the LCD surface. For more information see FIG4.

FIG. 2 Luminance

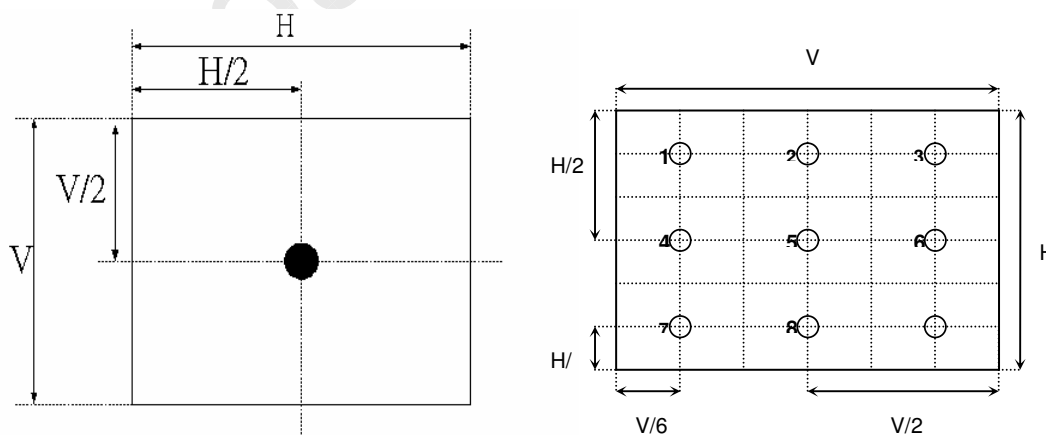



FIG.3 Response Time

The response time is defined as the following figure and shall be measured by switching the input signal for “any level of gray(bright)” and “any level of gray(dark)”.

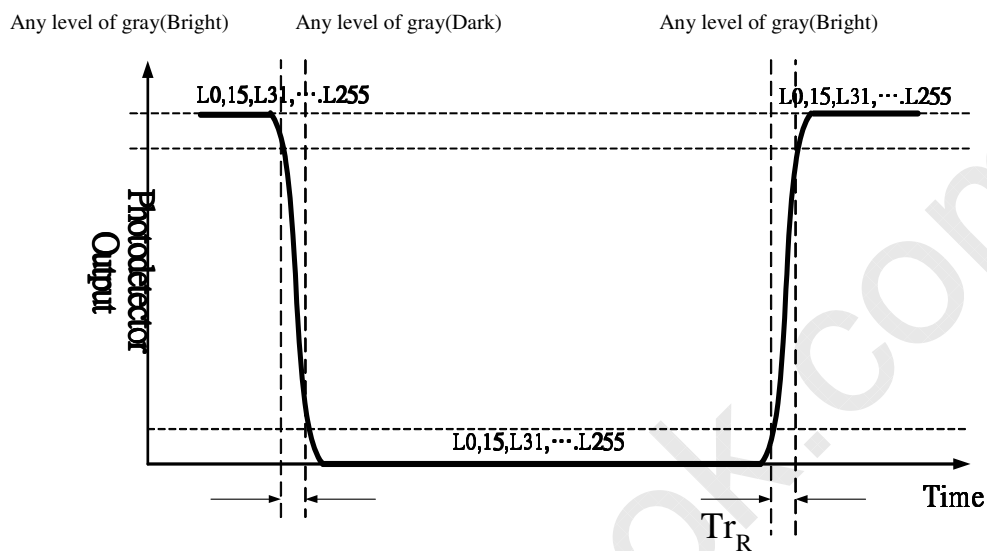
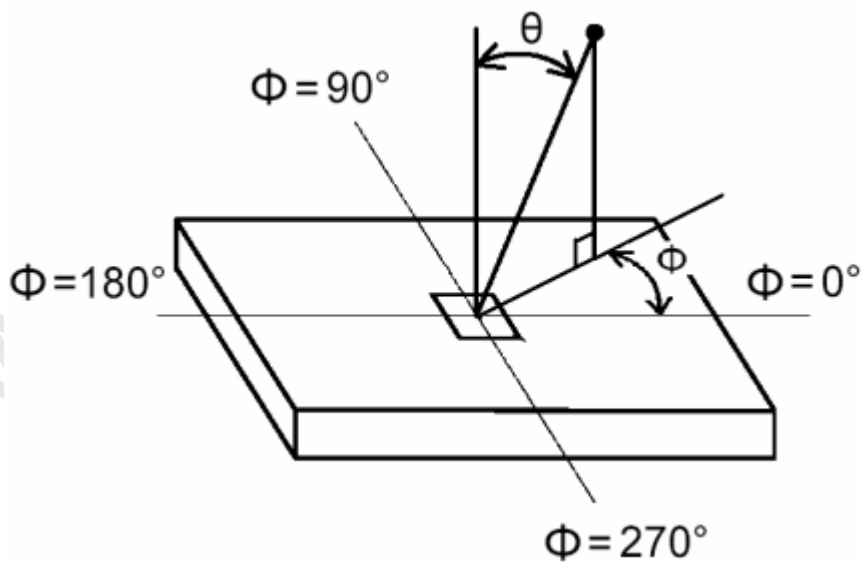

FIG.4 Viewing angle





5. Mechanical Characteristics

The contents provide general mechanical characteristics for the model T370HW02 VF. In addition the figures in the next page are detailed mechanical drawing of the LCD.

Outline Dimension	Horizontal	877.0 mm
	Vertical	516.8mm
	Depth	55.3 mm(with inverter)
Bezel Opening	Horizontal	827.8 mm
	Vertical	469.4 mm
Active Display Area	Horizontal	819.36 mm
	Vertical	460.89 mm
Weight	10000g (Typ.)	



Mechanical Figure:

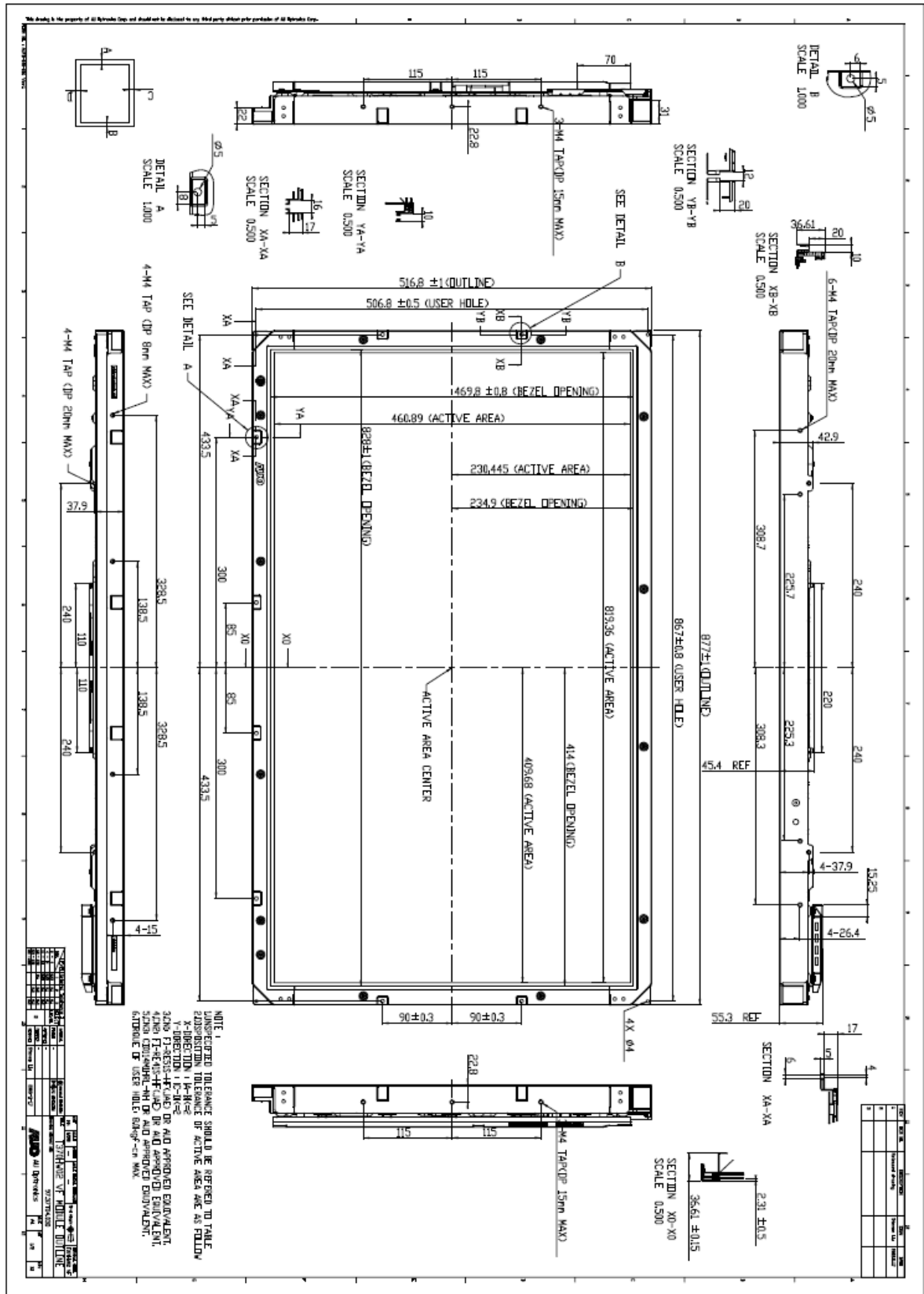



6. Reliability:

Environment test condition

	Test Items	Q'ty	Conditions
1	High Temperature Stroage	3	60°C 300 hrs
2	Low Temperature Stroage	3	-20°C, 300 hrs
3	High Temperature Operation	3	50°C, 300 hrs
4	Low Temperature Operation	3	-5°C, 300 hrs
5	Vibration (non-operation)	3	(10 ~ 300Hz/1.5G/11min SR, XYZ 30min/axis) Vibration level : 1.5G RMS, Bandwidth : 10-300Hz Duration: X, Y, Z 30min,
6	Shock (non-operation)	3	Shock level: 50G Waveform: have sine wave, 11ms Direction: ±X,±Y, ±Z One time each direction
7	Vibration (With carton)	3	Random wave (1.5 Grms 10~200Hz) 30mins / Per each X.Y.Z axes
8	Drop (With carton)	3	Height: 38cm 1 corner, 3 edges, 6 surfaces (ASTMD4169-I)



7. International Standard

7-1. Safety

- (1) UL1950 Third Edition, Underwriters Laboratories, Inc. Jan. 28, 1995

Standard for Safety of Information Technology Equipment Including electrical Business Equipment.

- (2) CAN/CSA C22.2 No. 950-95/60950 Third Edition, Canadian Standards Association,

Standard for Safety of Information Technology Equipment Including Electrical Business Equipment.

- (3) EN60950 : 1992+A2: 1993+A2: 1993+C3: 1995+A4: 1997+A11: 1997

IEC 950: 1991+A1: 1992+A2: 1993+C3: 1995+A4:1996

European Committee for Electrotechnical Standardization (CENELEC)

EUROPEAN STANDARD for Safety of Information Technology Equipment Including Electrical Business Equipment.

7-2. EMC

- a) ANSI C63.4 “Methods of Measurement of Radio-Noise Emissions from Low-Voltage Electrical and Electrical Equipment in the Range of 9kHz to 40GHz. “American National standards Institute(ANSI), 1992
- b) C.I.S.P.R “Limits and Methods of Measurement of Radio Interface Characteristics of Information Technology Equipment.” International Special committee on Radio Interference.
- c) EN 55022 “Limits and Methods of Measurement of Radio Interface Characteristics of Information Technology Equipment.” European Committee for Electrotechnical Standardization. (CENELEC), 1998



8. Packing

Panel label:



TW8800900028-ZM0200

TW88009: T: Taiwan, A/B: China

00028: Panel Serial Number

ZM0: AUO internal code

Manufactured 08/36: 2008 week 36

Made In Taiwan: Taiwan made

Carton Label:





Carton:

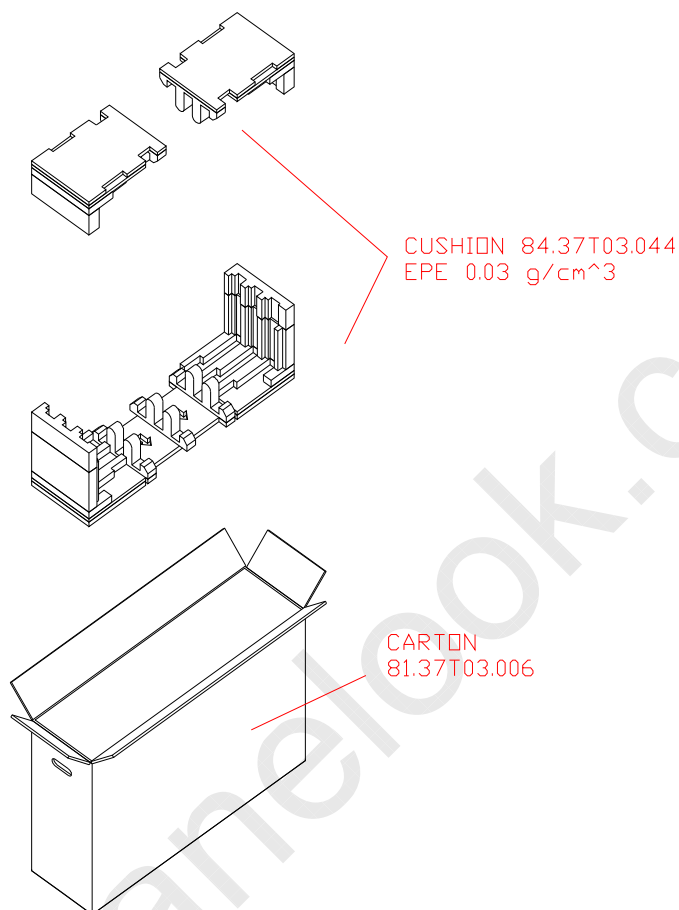

Pallet and Shipment information

	Item	Specification			Packing
		Qty.	Dimension	Weight (kg)	Remark
1	Packing BOX	3 pcs/box	965(L)mm*280(W)mm*610(H)mm	30	
2	Pallet	1	1140(L)mm*980(W)mm*140(H)mm	15	
3	Boxes per Pallet	8 boxes/Pallet (By Air) ; 12 Boxes/Pallet (By Sea)			
4	Panels per Pallet	24pcs/pallet(By Air) ; 36 Boxes/Pallet (By Sea)			
	Pallet after packing	24 (by Air)	1140(L)mm*980(W)mm*1360(H)mm (by Air)	257 (by Air)	
		36(by Sea)	1140(L)mm*980(W)mm*2110(H)mm (by Sea)	393 (by Sea)	

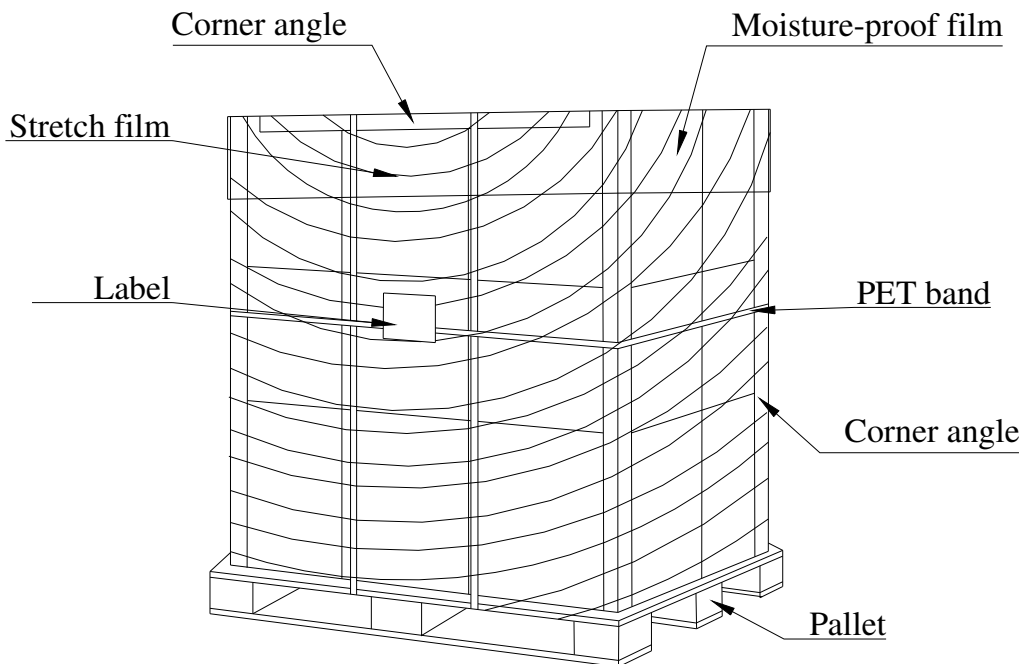

9. PRECAUTIONS

Please pay attention to the followings when you use this TFT LCD module.

9-1 MOUNTING PRECAUTIONS

- (1) You must mount a module using holes arranged in four corners or four sides.
- (2) You should consider the mounting structure so that uneven force (ex. Twisted stress) is not applied to module. And the case on which a module is mounted should have sufficient strength so that external force is not transmitted directly to the module.
- (3) Please attach the surface transparent protective plate to the surface in order to protect the polarizer. Transparent protective plate should have sufficient strength in order to resist external force.
- (4) You should adopt radiation structure to satisfy the temperature specification.
- (5) Acetic acid type and chlorine type materials for the cover case are not desirable because the former generates corrosive gas of attacking the polarizer at high temperature and the latter causes circuit break by electro-chemical reaction.
- (6) Do not touch, push or rub the exposed polarizers with glass, tweezers or anything harder than HB pencil lead. And please do not rub with dust clothes with chemical treatment. Do not touch the surface of polarizer for bare hand or greasy cloth. (Some cosmetics are detrimental to the polarizer.)
- (7) When the surface becomes dusty, please wipe gently with absorbent cotton or other soft materials like chamois soaks with petroleum benzene. Normal-hexane is recommended for cleaning the adhesives used to attach front/ rear polarizers. Do not use acetone, toluene and alcohol because they cause chemical damage to the polarizer.
- (8) Wipe off saliva or water drops as soon as possible. Their long time contact with polarizer causes deformations and color fading.
- (9) Do not open the case because inside circuits do not have sufficient strength.



9-2 OPERATING PRECAUTIONS

- (1) The device listed in the product specification sheets was designed and manufactured for TV application
- (2) The spike noise causes the mis-operation of circuits. It should be lower than following voltage:
 $V=\pm 200\text{mV}$ (Over and under shoot voltage)
- (3) Response time depends on the temperature. (In lower temperature, it becomes longer.)
- (4) Brightness depends on the temperature. (In lower temperature, it becomes lower.) And in lower temperature, response time (required time that brightness is stable after turned on) becomes longer.
- (5) Be careful for condensation at sudden temperature change. Condensation makes damage to polarizer or electrical contacted parts. And after fading condensation, smear or spot will occur.
- (6) When fixed patterns are displayed for a long time, remnant image is likely to occur.

Module has high frequency circuits. Sufficient suppression to the electromagnetic interference shall be done by system manufacturers. Grounding and shielding methods may be important to minimize the interface.

9-3 ELECTROSTATIC DISCHARGE CONTROL

Since a module is composed of electronic circuits, it is not strong to electrostatic discharge. Make certain that treatment persons are connected to ground through wrist band etc. And don't touch interface pin directly.

9-4 PRECAUTIONS FOR STRONG LIGHT EXPOSURE

Strong light exposure causes degradation of polarizer and color filter.

9-5 STORAGE+

When storing modules as spares for a long time, the following precautions are necessary.

- (1) Store them in a dark place. Do not expose the module to sunlight or fluorescent light. Keep the temperature between 5°C and 35°C at normal humidity.
- (2) The polarizer surface should not come in contact with any other object. It is recommended that they be stored in the container in which they were shipped.

9-6 HANDLING PRECAUTIONS FOR PROTECTION FILM

- (1) The protection film is attached to the bezel with a small masking tape. When the protection film is peeled off, static electricity is generated between the film and polarizer. This should be peeled off slowly and carefully by people who are electrically grounded and with well ion-blown equipment or in such a condition, etc.
- (2) When the module with protection film attached is stored for a long time, sometimes there remains a very small amount of glue still on the Bezel after the protection film is peeled off.
- (3) You can remove the glue easily. When the glue remains on the Bezel or its vestige is recognized, please wipe them off with absorbent cotton waste or other soft material like chamois soaked with normal-hexane.

www.panelook.com