



Update date: 2009/5/21

Product Specifications

37" HDTV Color TFT-LCD Module

Model Name: T370HW03. V2

() Preliminary Specifications

(* Final Specifications



Contents

No	
	COVER
	CONTENTS
	RECORD OF REVISIONS
1	GENERAL DESCRIPTION
2	ABSOLUTE MAXIMUM RATINGS
3	ELECTRICAL SPECIFICATIONS
3-1	ELECTRICAL CHARACTERISTIC
3-2	INTERFACE CONNECTIONS
3-3	SIGNAL TIMING SPECIFICATIONS
3-4	SIGNAL TIMING WAVEFORMS
3-5	COLOR INPUT DATA REFERENCE
3-6	POWER SEQUENCE
4	OPTICAL CHARACTERISTICS
5	MECHANICAL CHARACTERISTICS
6	RELIABILITY
7	INTERNATIONAL STANDARDS
7-1	SAFETY
7-2	EMC
8	PACKING
9	PRECAUTIONS



Record of Revision

Version	Date	No	Old Description	New Description	Remark
0	2009.3.24		First draft		
1	2009,04,23			Update cycle to cycle jitter	
2	2009,05,14			Update 25°C V _S	
3	2009,05,21			Update packing information	



1. General Description

This specification applies to the 37.0 inch Color TFT-LCD Module T370HW03 V2. This LCD module has a TFT active matrix type liquid crystal panel 1920x1080 pixels, and diagonal size of 37.0 inch. This module supports 1920x1080 HDTV mode (Non-interlace). Each pixel is divided into Red, Green and Blue sub-pixels or dots which are arranged in vertical stripes. Gray scale or the brightness of the sub-pixel color is determined with a 10-bit gray scale signal for each dot.

This model use 2008 Front Mount Bezel structure with narrow bezel design.

The T370HW03 V2 has been designed to apply the 8-bit+FRC 4 channel LVDS interface method. It is intended to support displays where high brightness, wide viewing angle, high color saturation, and high color depth are very important.

The T370HW03 V2 model is RoHS verified which can be distinguished on panel label.

* General Information

Items	Specification	Unit	Note
Active Screen Size	37.01	inch	
Display Area	819.36 (H) x 460.89(V)	mm	
Outline Dimension	855.8(H)x497.4(V)x44.9(D)	mm	
Driver Element	a-Si TFT active matrix		
Display Colors	8 bit +FRC,1.074B	Colors	
Number of Pixels	1920 x 1080	Pixel	
Pixel Pitch	0.42675(H) x 0.42675(W)	mm	
Pixel Arrangement	RGB vertical stripe		
Display Operation Mode	Normally Black		
Surface Treatment	AG Haze= 11%, 3H		
Weight	9,000(Max)	g	
Lamp quantity, type	16, Straight type	Pcs	



2. Absolute Maximum Ratings

The following are maximum values that, if exceeded, may cause permanent damage to the device.

Item	Symbol	Min	Max	Unit	Note
Logic/LCD Drive Voltage	Vcc	-0.3	14	[Volt]	[1]
Input Voltage of Signal	Vin	-0.3	4	[Volt]	[1]
Operating Temperature	TOP	0	50	[°C]	[2]
Operating Humidity	HOP	10	90	[%RH]	[2]
Storage Temperature	TST	-20	60	[°C]	[2]
Storage Humidity	HST	10	90	[%RH]	[2]
Panel surface temperature	PST		65	[°C]	

Note 1: Duration = 50msec

Note 2 : Maximum Wet-Bulb should be 39°C and No condensation.

The relative humidity must not exceed 90% non-condensing at temperatures of 40°C or less. At temperatures greater than 40°C, the wet bulb temperature must not exceed 39°C.

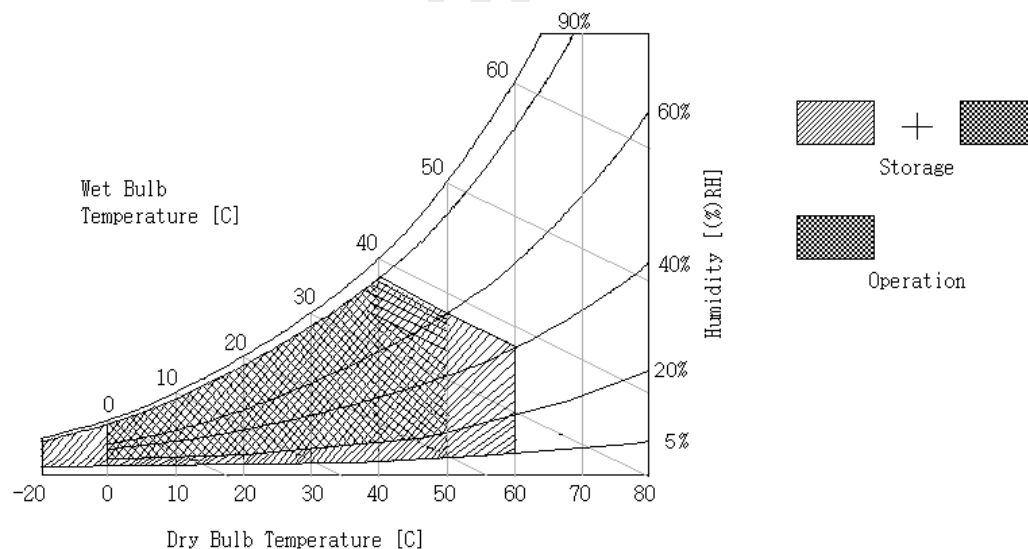



3. Electrical Characteristics

The T370HW03 V2 requires two power inputs. One is employed to power the LCD electronics and to drive the TFT array and liquid crystal. The second input power for the BLU, is to power lamps.

3-1 Electrical Characteristics

(Ta=25±2°C)

Parameter		Symbol	Values			Unit	Notes
			Min	Typ	Max		
Power Supply Input Voltage		V _{CC}	10.8	12.0	13.2	Vdc	
Power Supply Input Current		I _{CC}		1	1.2	A	[1]
Power Consumption		P _C	-	12	14.4	Watt	[1]
Inrush Current		I _{RUSH}	-		4	Apeak	[2]
LVDS Interface	Differential Input High Threshold Voltage	V _{TH}			100	mV	[3]
	Differential Input Low Threshold Voltage	V _{TL}	-100			mV	[3]
	Common Input Voltage	V _{ICM}	1.0	1.2	1.4	V	
	LVDS Clock to Data Skew Margin	t _{RMG}	-0.4	-	+0.4	ns	[7] 66MHz ≤ Fclk ≤ 80MHz
	LVDS Clock to Clock Skew Margin(Cycle to Cycle jitter)	t _{RCL}	-2%	-	+2%	Tclk	[8] 66MHz ≤ Fclk ≤ 80MHz
	Differential input voltage	V _{ID}	100	400	600	mV	
CMOS Interface	Input High Threshold Voltage	V _{IH} (High)	2.4		3.3	Vdc	
	Input Low Threshold Voltage	V _{IL} (Low)	0		0.9	Vdc	
Life Time			50000			Hours	

Note :

- The check pattern is base on white pattern. The ripple voltage should be controlled under 10% of V_{CC}
V_{CC}=12.0V, f_v = 120Hz, fCLK=75Mhz for one channel, 25°C, Test Pattern : White Pattern



2. Measurement condition :

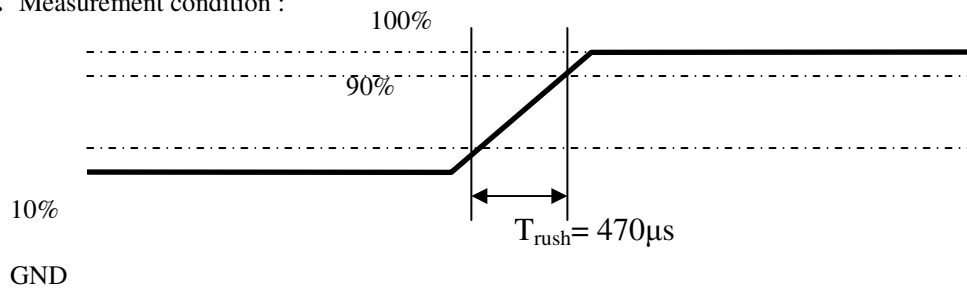

Figure 1: Measurement of I_{rush}

3. Measurement of LVDS differential voltage is shown in Figure 2.

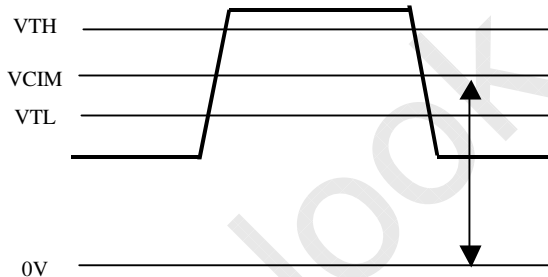

Figure 2 : LVDS Differential Voltage

4. The performance of the Lamp in LCM, for example life time or brightness, is extremely influenced by the characteristics of the DC-AC Inverter. So all the parameters of an inverter should be carefully designed so as not to produce too much leakage current from high-voltage output of the inverter. When you design or order the inverter, please make sure unwanted lighting caused by the mismatch of the lamp and the inverter (no lighting, flicker, etc) never occurs. When you confirm it, the LCD Assembly should be operated in the same condition as installed in your instrument.
5. Do not attach a conducting tape to lamp connecting wire. If the lamp wire attach to conducting tape, TFT-LCD Module have a low luminance and the inverter has abnormal action because leakage current occurs between lamp wire and conducting tape.
6. The relative humidity must not exceed 90% non-condensing at temperatures of 40°C or less. At temperatures greater than 40°C, the wet bulb temperature must not exceed 39°C. When operate at low temperatures, the brightness of CCFL will drop and the life time of CCFL will be reduced.
7. Measurement of **LVDS Clock to Data Skew Margin** is shown in Figure 3.

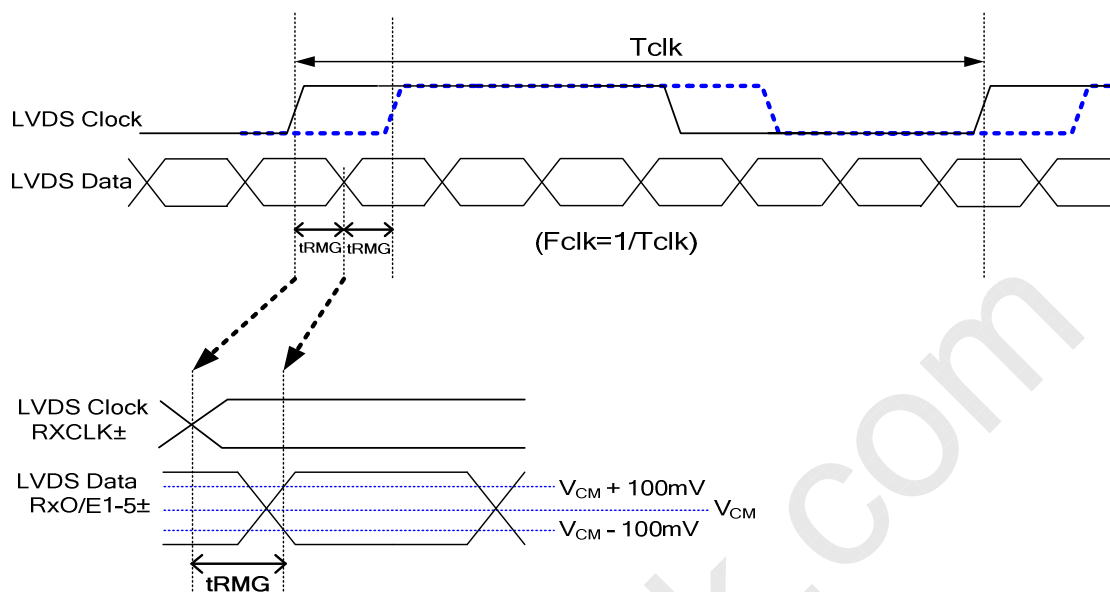

Figure 3: LVDS Clock to Data Skew Margin

8. Measurement of LVDS Clock to Clock Skew Margin is shown in Figure 4.

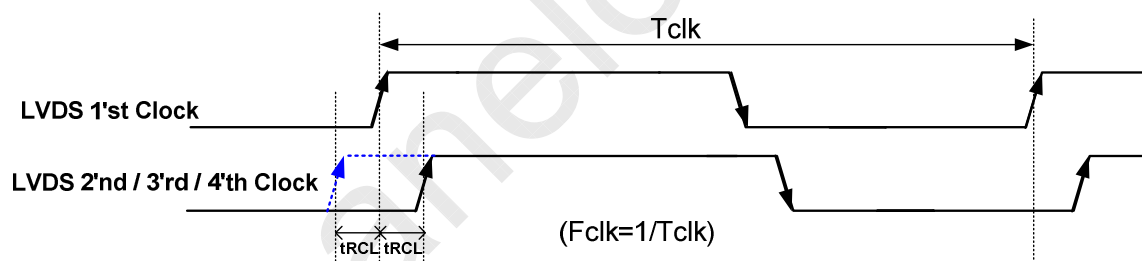

Figure 4: LVDS Clock to Clock Skew Margin



3-2 Interface Connections

LCD connector : JAE FI-RE51S-HF

Pin No	Symbol	Description	Note
1	Reserve	AUO internal use	
2	Reserve	AUO internal use	
3	Reserve	AUO internal use	
4	Reserve	AUO internal use	
5	Reserve	AUO internal use	
6	Reserve	AUO internal use	
7	LVDS Option	Low/Open for Normal (NS), High for JEIDA	Default : NS mode
8	Reserve	AUO internal use	
9	Reserve	AUO internal use	
10	Reserve	AUO internal use	
11	GND	Ground	
12	R1_0-	LVDS Channel 1, Signal 0-	Channel 1
13	R1_0+	LVDS Channel 1, Signal 0+	
14	R1_1-	LVDS Channel 1, Signal 1-	
15	R1_1+	LVDS Channel 1, Signal 1+	
16	R1_2-	LVDS Channel 1, Signal 2-	
17	R1_2+	LVDS Channel 1, Signal 2+	
18	GND	Ground	
19	R1_CLK-	LVDS Channel 1, Clock -	
20	R1_CLK+	LVDS Channel 1, Clock +	
21	GND	Ground	
22	R1_3-	LVDS Channel 1, Signal 3-	
23	R1_3+	LVDS Channel 1, Signal 3+	
24	R1_4-	LVDS Channel 1, Signal 4-	
25	R1_4+	LVDS Channel 1, Signal 4+	
26	GND	Ground	
27	GND	Ground	
28	R2_0-	LVDS Channel 2, Signal 0-	Channel 2
29	R2_0+	LVDS Channel 2, Signal 0+	
30	R2_1-	LVDS Channel 2, Signal 1-	
31	R2_1+	LVDS Channel 2, Signal 1+	
32	R2_2-	LVDS Channel 2, Signal 2-	
33	R2_2+	LVDS Channel 2, Signal 2+	
34	GND	Ground	
35	R2_CLK-	LVDS Channel 2, Clock -	
36	R2_CLK+	LVDS Channel 2, Clock +	
37	GND	Ground	
38	R2_3-	LVDS Channel 2, Signal 3-	



39	R2_3+	LVDS Channel 2, Signal 3+	Power
40	R2_4-	LVDS Channel 2, Signal 4-	
41	R2_4+	LVDS Channel 2, Signal 4+	
42	GND	Ground	
43	GND	Ground	
44	GND	Ground	
45	GND	Ground	
46	GND	Ground	
47	V _{DD}	Operating Voltage supply, +12V DC regulated	
48	V _{DD}	Operating Voltage supply, +12V DC regulated	
49	V _{DD}	Operating Voltage supply, +12V DC regulated	
50	V _{DD}	Operating Voltage supply, +12V DC regulated	
51	V _{DD}	Operating Voltage supply, +12V DC regulated	

JAE FI-RE41S-HF

Pin No	Symbol	Description	Note
1	NC	No Connect	
2	NC	No Connect	
3	NC	No Connect	
4	NC	No Connect	
5	NC	No Connect	
6	NC	No Connect	
7	NC	No Connect	
8	NC	No Connect	
9	GND	Ground	
10	R3_0-	LVDS Channel 3, Signal 0-	Channel 3
11	R3_0+	LVDS Channel 3, Signal 0+	
12	R3_1-	LVDS Channel 3, Signal 1-	
13	R3_1+	LVDS Channel 3, Signal 1+	
14	R3_2-	LVDS Channel 3, Signal 2-	
15	R3_2+	LVDS Channel 3, Signal 2+	
16	GND	Ground	
17	R3_CLK-	LVDS Channel 3, Clock -	
18	R3_CLK+	LVDS Channel 3, Clock +	
19	GND	Ground	
20	R3_3-	LVDS Channel 3, Signal 3-	
21	R3_3+	LVDS Channel 3, Signal 3+	
22	R3_4-	LVDS Channel 3, Signal 4-	
23	R3_4+	LVDS Channel 3, Signal 4+	
24	GND	Ground	
25	GND	Ground	
26	R4_0-	LVDS Channel 4, Signal 0-	Channel 4
27	R4_0+	LVDS Channel 4, Signal 0+	



28	R4_1-	LVDS Channel 4, Signal 1-
29	R4_1+	LVDS Channel 4, Signal 1+
30	R4_2-	LVDS Channel 4, Signal 2-
31	R4_2+	LVDS Channel 4, Signal 2+
32	GND	Ground
33	R4_CLK-	LVDS Channel 4, Clock -
34	R4_CLK+	LVDS Channel 4, Clock +
35	GND	Ground
36	R4_3-	LVDS Channel 4, Signal 3-
37	R4_3+	LVDS Channel 4, Signal 3+
38	R4_4-	LVDS Channel 4, Signal 4-
39	R4_4+	LVDS Channel 4, Signal 4+
40	GND	Ground
41	GND	Ground

Note:

1. All GND (ground) pins should be connected together and should also be connected to the LCD's metal frame.
All Vcc (power input) pins should be connected together.



Dual LVDS Channel Color Mapping

LVDS Option = L (GND) or OPEN = NS

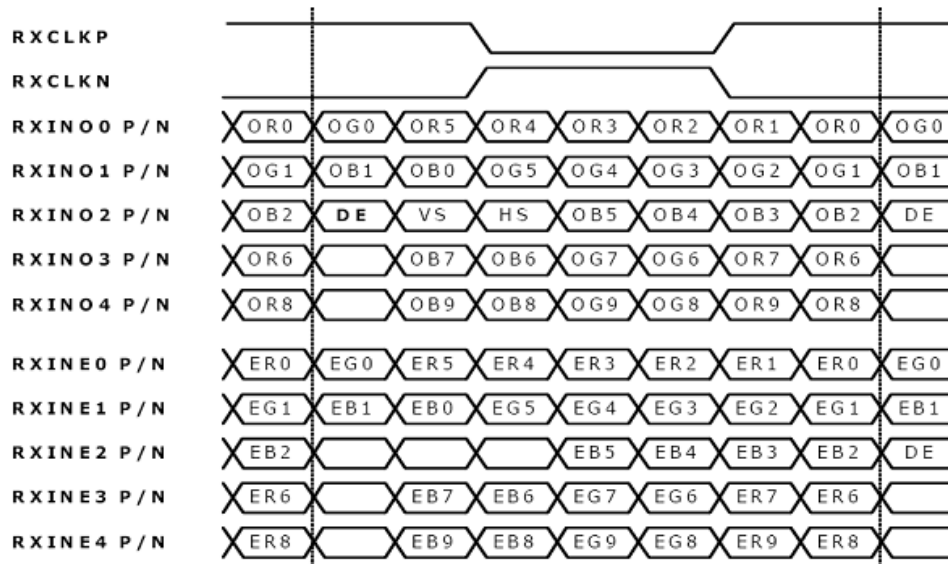

LVDS Option = H (3.3V) → JEIDA

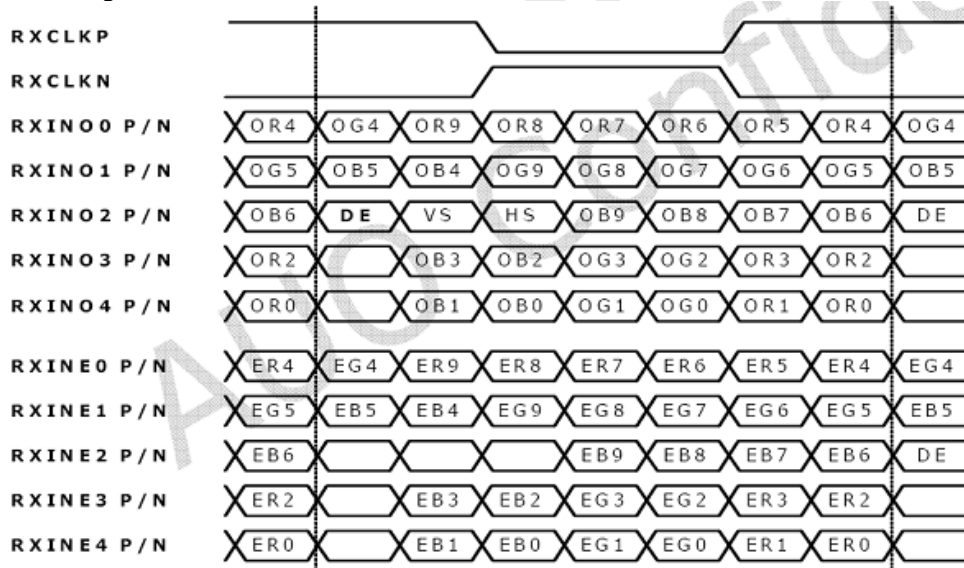



Backlight Specification

1. Electrical specification

Description		Min	Typ	Max	Unit	Condition		
1	BL Operating Voltage VBL	1130	1330	1530	Vrms	1. BL one side operating voltage at boost dimming ration 100% 2. Base on JAR measurement data (note 1.)		
2	BL Operating Current IBL	131	138	145	mArms	1. Each lamp current=8.6mA 2. BL one side operating current at boost dimming ration 100%		
3	BL Total Power Dissipation PBL	137	145	152	Watt	1. Dimming at 100% 2. IPI board input power=154W(typ)		
4	Starting Voltage	At 0°C	Vs	1950	2100	2250	Vrms	1.BL one side striking voltage when open connector
		At 25°C	Vs	1800	1950	2100		
5	Operating frequency fo	60	62	64	kHz			
6	Striking time Ts	1.5	-		msec			
7	PWM Operating Frequency F_PWM	95	-	240	Hz			
8	External PWM Dimming Duty ratio D_PWM	10	-	100	%	Note2		
9	Lamp type	Straight type						
10	Number of lamps	16			pcs			
11	Type of current balance	Capacitor						
12	C ballast Cb	17.1	18	18.9	pF	18pf/6kV		

(Ta=25±5°C, Turn on for 45 minutes)

Note 1:

$$V_{BL} = \sqrt{\left(\frac{V_L}{2}\right)^2 + (V_C)^2}$$

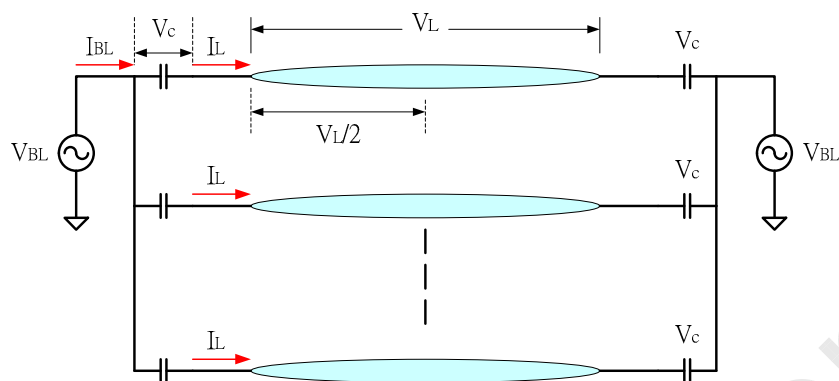

Note2: (a) Uniformity and flicker does not guarantee below 20% dimming control.
 (b) 10% dimming function okay and no backlight shut down

2. Lamp specification

	Description	Min	Typ	Max	Unit	
1	Lamp Voltage	Vlamp	1035	1050	1065	Vrms
2	Lamp Current	Ilamp	8.2	8.6	9	mArms
3	Lamp frequency	flamp	30	45	80	KHz
4	Starting Voltage	At 25°C	-	-	1450	Vrms
		At 0°C	-	-	1740	Vrms
5	Discharge Stabilization Time	Ts	-	-	3	min
6	Striking time	Ts	-	-	500	msec
7	Life time (Ilamp=8.6mA)	50K	60K			-



Inverter units

Connector Type : Cvilux CI063PIH0J-NH

Connector pin define is shown below:

CN1:

PIN #	Symbol	Description
1	High	I/P board high voltage supply
2	N.C.	No connection
3	High	I/P board high voltage supply

CN2:

PIN #	Symbol	Description
1	High	I/P board high voltage supply
2	N.C.	No connection
3	High	I/P board high voltage supply

Measurement method

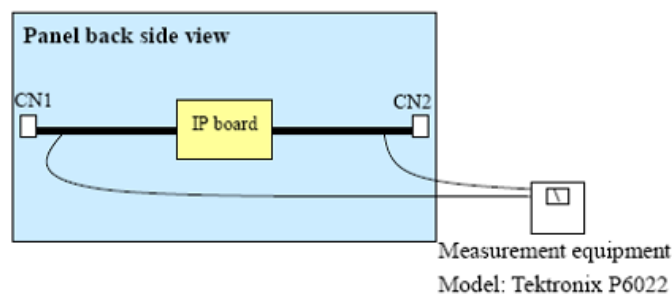



3-3 Signal Timing Specifications

This is the signal timing required at the input of the User connector. All of the interface signal timing should be satisfied with the following specifications for its proper operation.

* Timing Table DE only Mode

Signal	Item	Symbol	Min	Type	Max	Unit
Vertical Section	Period	Tv	1090	1130	1392	Th
	Active	Tdisp (v)	1080			Th
	Blanking	Tblk (v)	10	50	312	Th
Horizontal Section	Period	Th	550	570	580	Tclk
	Active	Tdisp (h)	480			Tclk
	Blanking	Tblk (h)	70	90	100	Tclk
Clock	Frequency	1/Tclk	67.2	77.29	80.74	MHz
Vertical Frequency	Frequency	Freq	96	120	122	Hz
Horizontal Frequency	Frequency	Freq	120	135.6	139.2	KHz

Notes:

1.) Display position is specific by the rise of DE signal only.

Horizontal display position is specified by the rising edge of 1st DCLK after the rise of 1st DE, is displayed on the left edge of the screen.

Vertical display position is specified by the rise of DE after a "Low" level period equivalent to eight times of horizontal period. The 1st data corresponding to one horizontal line after the rise the of 1st DE is displayed at the top line of screen.

3.) If a period of DEB "High" is less than 1920 DCLK or less than 1080 lines, the rest of the screen displays black.

4.) The display position does not fit to the screen if a period of DE "High" and the effective data period do not synchronize with each other.



3-4 Signal Timing Waveforms

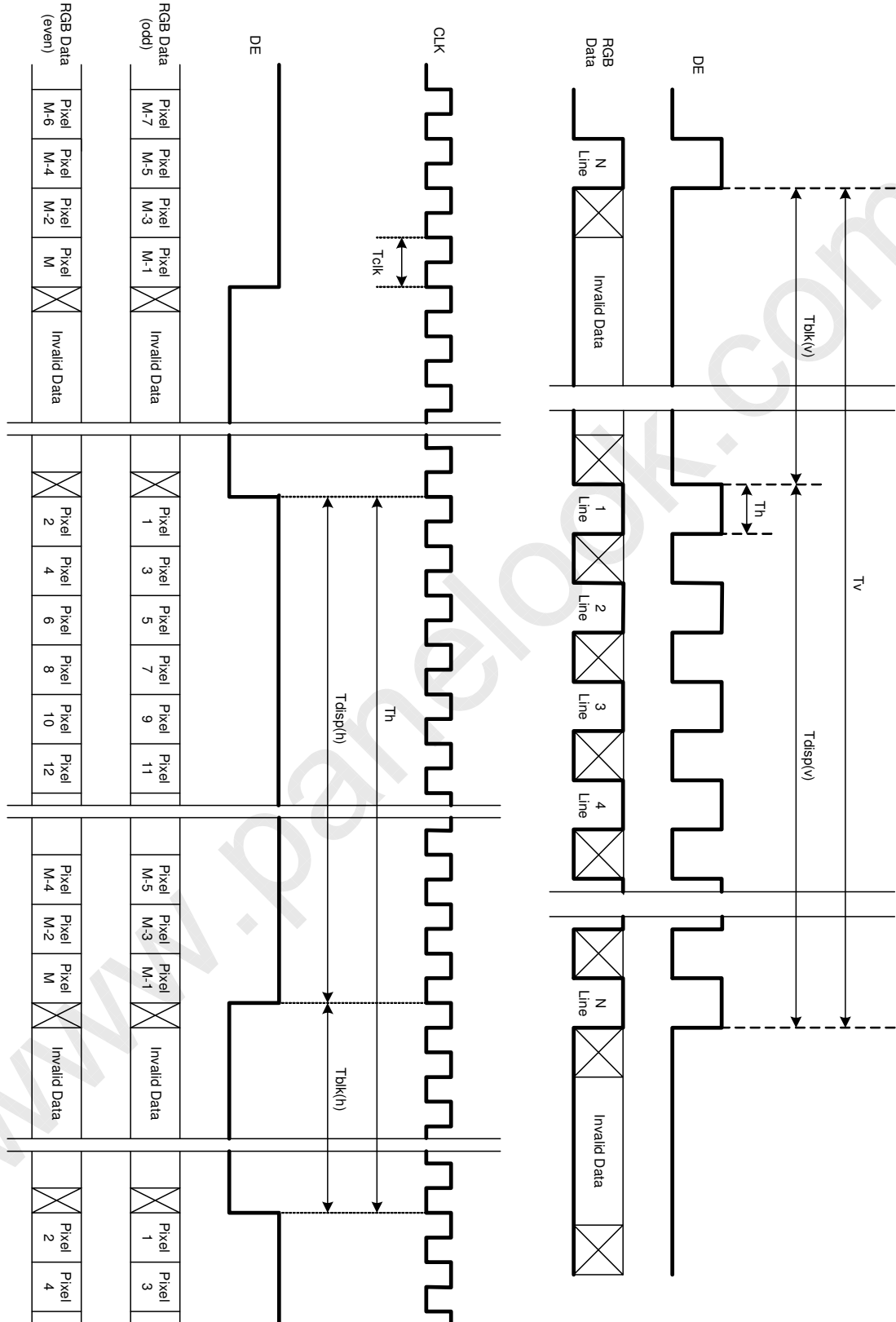



3-5 Color input data assignment

The brightness of each primary color (red, green and blue) is based on the 10 bit gray scale data input for the color; the higher the binary input, the brighter the color. The table below provides a reference for color versus data input.

COLOR DATA REFERENCE

Color		Input Color Data																													
		RED										GREEN										BLUE									
		MSB					LSB					MSB					LSB					MSB					LSB				
		R9	R8	R7	R6	R5	R4	R3	R2	R1	R0	G9	G8	G7	G6	G5	G4	G3	G2	G1	G0	B9	B8	B7	B6	B5	B4	B3	B2	B1	B0
Basic Color	Black	0	0	0	0	0	0	0	0	0	0	0	0	0	0	0	0	0	0	0	0	0	0	0	0	0	0	0	0	0	0
	Red(1023)	1	1	1	1	1	1	1	1	1	1	0	0	0	0	0	0	0	0	0	0	0	0	0	0	0	0	0	0	0	0
	Green(1023)	0	0	0	0	0	0	0	0	0	0	1	1	1	1	1	1	1	1	1	1	0	0	0	0	0	0	0	0	0	0
	Blue(1023)	0	0	0	0	0	0	0	0	0	0	0	0	0	0	0	0	0	0	0	0	1	1	1	1	1	1	1	1	1	1
	Cyan	0	0	0	0	0	0	0	0	0	0	1	1	1	1	1	1	1	1	1	1	1	1	1	1	1	1	1	1	1	1
	Magenta	1	1	1	1	1	1	1	1	1	1	0	0	0	0	0	0	0	0	0	0	1	1	1	1	1	1	1	1	1	1
	Yellow	1	1	1	1	1	1	1	1	1	1	1	1	1	1	1	1	1	1	1	1	0	0	0	0	0	0	0	0	0	0
	White	1	1	1	1	1	1	1	1	1	1	1	1	1	1	1	1	1	1	1	1	1	1	1	1	1	1	1	1	1	1
RED	RED(0000)	0	0	0	0	0	0	0	0	0	0	0	0	0	0	0	0	0	0	0	0	0	0	0	0	0	0	0	0	0	0
	RED(0001)	0	0	0	0	0	0	0	0	0	1	0	0	0	0	0	0	0	0	0	0	0	0	0	0	0	0	0	0	0	0

	RED(1022)	1	1	1	1	1	1	1	1	1	0	0	0	0	0	0	0	0	0	0	0	0	0	0	0	0	0	0	0	0	0
RED(1023)	1	1	1	1	1	1	1	1	1	1	0	0	0	0	0	0	0	0	0	0	0	0	0	0	0	0	0	0	0	0	
GREEN	GREEN(0000)	0	0	0	0	0	0	0	0	0	0	0	0	0	0	0	0	0	0	0	0	0	0	0	0	0	0	0	0	0	0
	GREEN(0001)	0	0	0	0	0	0	0	0	0	0	0	0	0	0	0	0	0	0	0	1	0	0	0	0	0	0	0	0	0	0

	GREEN(1022)	0	0	0	0	0	0	0	0	0	0	1	1	1	1	1	1	1	1	1	0	0	0	0	0	0	0	0	0	0	0
GREEN(1023)	0	0	0	0	0	0	0	0	0	0	1	1	1	1	1	1	1	1	1	1	0	0	0	0	0	0	0	0	0	0	
BLUE	BLUE(0000)	0	0	0	0	0	0	0	0	0	0	0	0	0	0	0	0	0	0	0	0	0	0	0	0	0	0	0	0	0	0
	BLUE(0001)	0	0	0	0	0	0	0	0	0	0	0	0	0	0	0	0	0	0	0	0	0	0	0	0	0	0	0	0	0	1

	BLUE(1022)	0	0	0	0	0	0	0	0	0	0	0	0	0	0	0	0	0	0	0	0	1	1	1	1	1	1	1	1	1	0
BLUE(1023)	0	0	0	0	0	0	0	0	0	0	0	0	0	0	0	0	0	0	0	0	1	1	1	1	1	1	1	1	1	1	



3-6 Power Sequence of LCD Module

3.6.1 Power Sequence for LCD

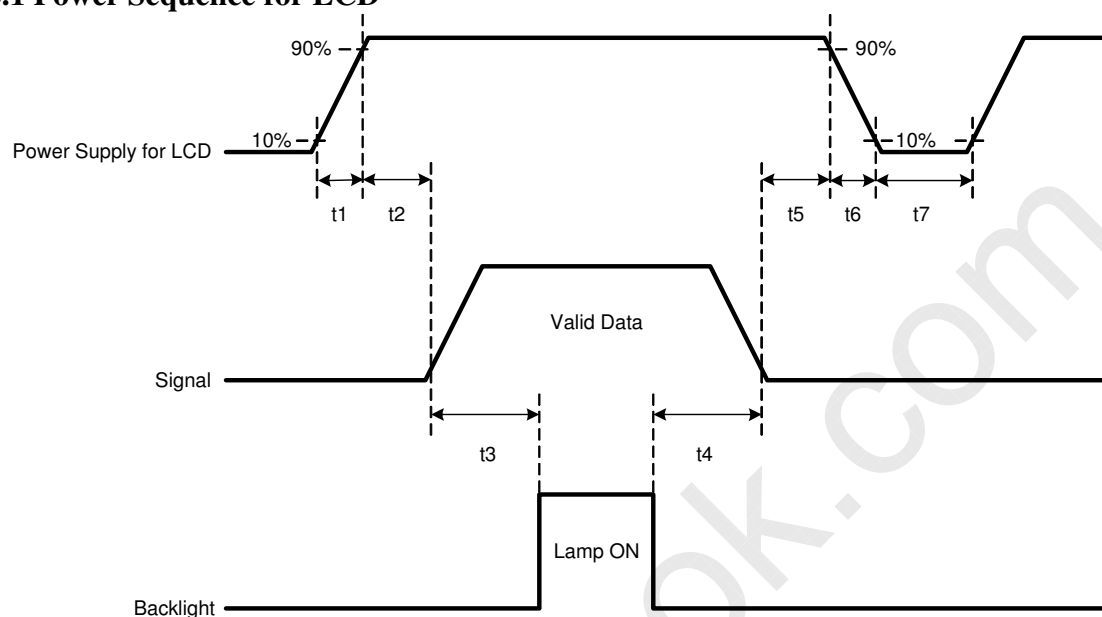

Parameter	Values			Units
	Min.	Typ.	Max.	
T1	0.4	-	30	ms
T2	0.1	-	50	ms
T3	300	-	-	ms
T4	10	-	-	ms
T5	0.1	-	50	ms
T6	-	-	300	ms
T7	500	-	-	ms

Note:

The timing controller will not be damaged in case of TV set AC input power suddenly shut down. Once power reset, it should follow power sequence as spec. definition.

- (1) Apply the lamp voltage within the LCD operation range. When the back-light turns on before the LCD operation or the LCD turns off before the back-light turns off, the display may momentarily become abnormal screen.



4. Optical Specification

Optical characteristics are determined after the unit has been 'ON' and stable for approximately 45 minutes in a dark environment at 25°C. The values specified are at an approximate distance 50cm from the LCD surface at a viewing angle of Φ and θ equal to 0°.

Testing Condition:

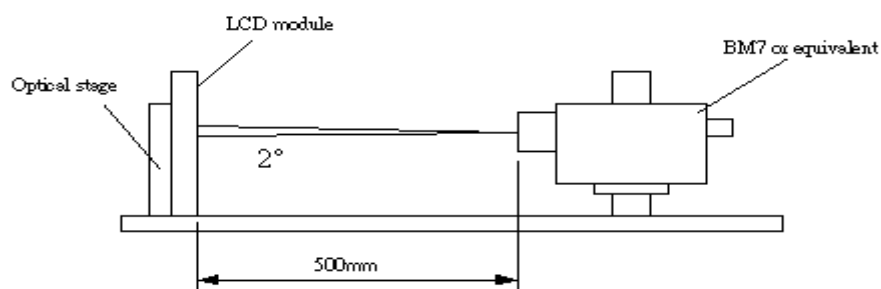

FIG.1 Measurement equipment

Parameter	Symbol	Condition	Value			Units	Notes	
			Min.	Typ.	Max.			
Contrast Ratio	CR	$\varphi = 0^\circ, \theta = 0^\circ$ Viewing Normal angle	4000	5000			1	
Surface Luminance, white	LWH		400	500		cd/m ²	2	
Gamma			2.1	2.3	2.5			
Luminance Variation	δ_{WHITE} 9 pts				1.3		3	
Response Time	Gray to Gray		T_γ		8		ms	4
Color gamut	NTSC				72		%	
Color Coordinates (CIE 1931)	RED		R_X	Typ -0.03	0.64	Typ +0.03		
			R_Y		0.33			
	GREEN		G_X		0.29			
			G_Y		0.6			
	BLUE	B_X	0.15					
		B_Y	0.06					
WHITE	W_X	0.280						
	W_Y	0.290						
Viewing Angle	x axis, right	θ_r ($\varphi = 0^\circ$)	CR \geq 10	89		Degree	5	
	x axis, left	θ_l ($\varphi = 180^\circ$)		89				
	y axis, up	θ_u ($\varphi = 90^\circ$)		89				
	y axis, down	θ_d ($\varphi = 270^\circ$)		89				

($T_a = 25 \pm 2^\circ\text{C}$)



Note:

1. Contrast ratio will be measured in the center of panel (point 5 in Figure 2), Contrast Ratio (CR) is defined mathematically as:

$$\text{Contrast Ratio} = \frac{\text{Surface Luminance of } L_{\text{on5}}}{\text{Surface Luminance of } L_{\text{off5}}}$$

2. Surface luminance is luminance value at point 5 across the LCD surface 50cm from the surface with all pixels displaying white. From more information see FIG 2. When $V_{\text{DDB}} = 24\text{V}$, $I_{\text{DDB}} = 6.04\text{A}$. $L_{\text{WH}} = L_{\text{O5}}$. Where L_{on5} is the luminance with all pixels displaying white at center 5 location.
3. The variation in surface luminance, δ_{WHITE} is defined (center of Screen) as:

$$\delta_{\text{WHITE(9P)}} = \frac{\text{Maximum}(L_{\text{on1}}, L_{\text{on2}}, \dots, L_{\text{on9}})}{\text{Minimum}(L_{\text{on1}}, L_{\text{on2}}, \dots, L_{\text{on9}})}$$
4. Response time T_{γ} is the average time required for display transition by switching the input signal for five luminance ratio (0%,25%,50%,75%,100% brightness matrix) and is based on $f_v = 120\text{Hz}$ to optimize.

	0%	25%	50%	75%	100%
0%		t0%-25%	t0%-50%	t0%-75%	t0%-100%
25%	t25%-0%		t25%-50%	t25%-75%	t25%-100%
50%	t50%-0%	t50%-25%		t50%-75%	t50%-100%
75%	t75%-0%	t75%-25%	t75%-50%		t75%-100%
100%	t100%-0%	t100%-25%	t100%-50%	t100%-75%	

5. Viewing angle is the angle at which the contrast ratio is greater than 10. The angles are determined for the horizontal or x axis and the vertical or y axis with respect to the z axis which is normal to the LCD surface. For more information see FIG4.

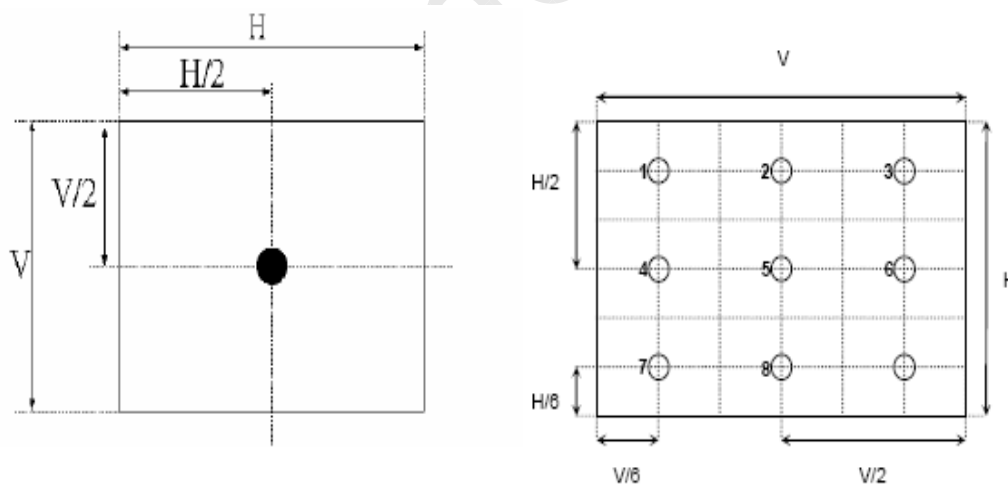

FIG. 2 Luminance measurement positions

The response time is defined as the following figure and shall be measured by switching the input signal for “any level of gray(bright)” and “any level of gray(dark)”.

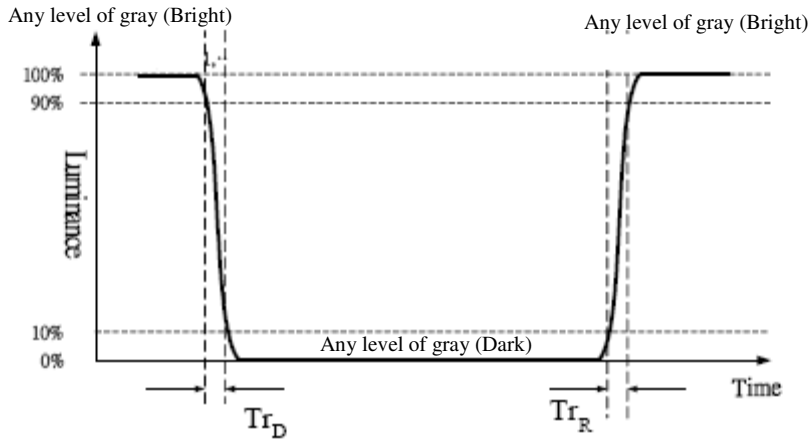

FIG.3 Measurement of Response Time

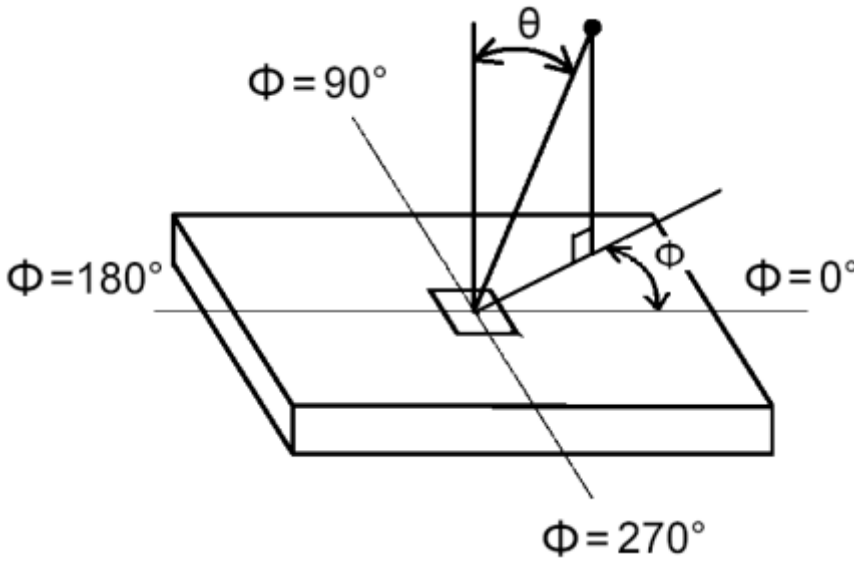

FIG.4 Measurement of viewing angle



5. Mechanical Characteristics

The contents provide general mechanical characteristics for the model T370HW03 V2. Detailed mechanical drawings are shown in the following pages.

Outline Dimension	Horizontal	855.8 mm
	Vertical	497.4 mm
	Depth	44.9 mm
Bezel Opening	Horizontal	827.8 mm
	Vertical	469.4 mm
Active Display Area	Horizontal	819.36 mm
	Vertical	460.89 mm
Weight	9,000g (Max.)	

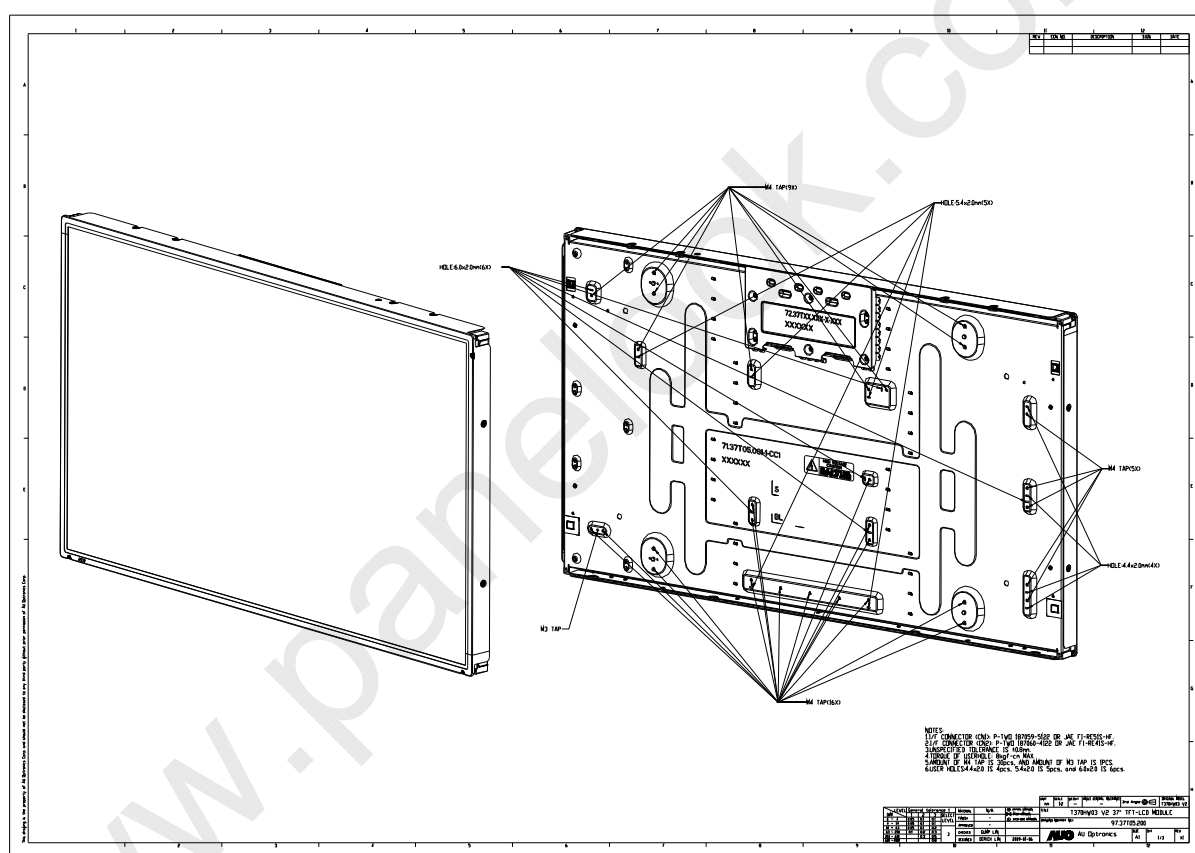



Mechanical Figure:

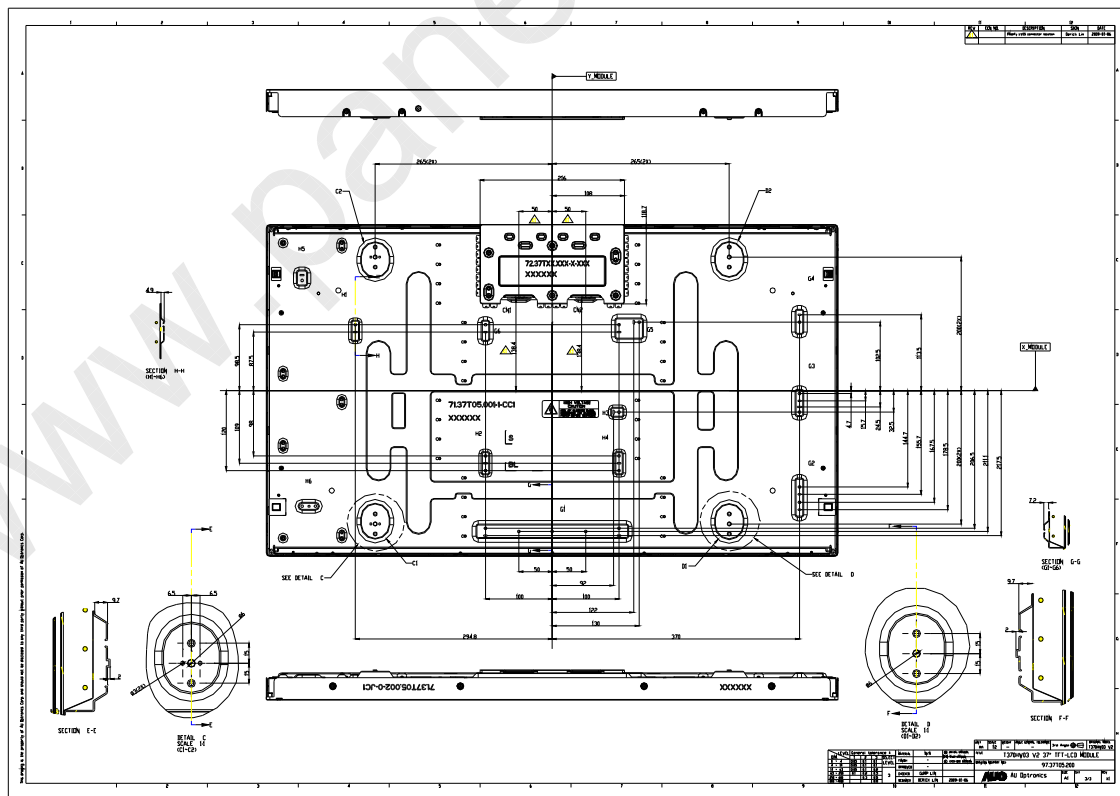
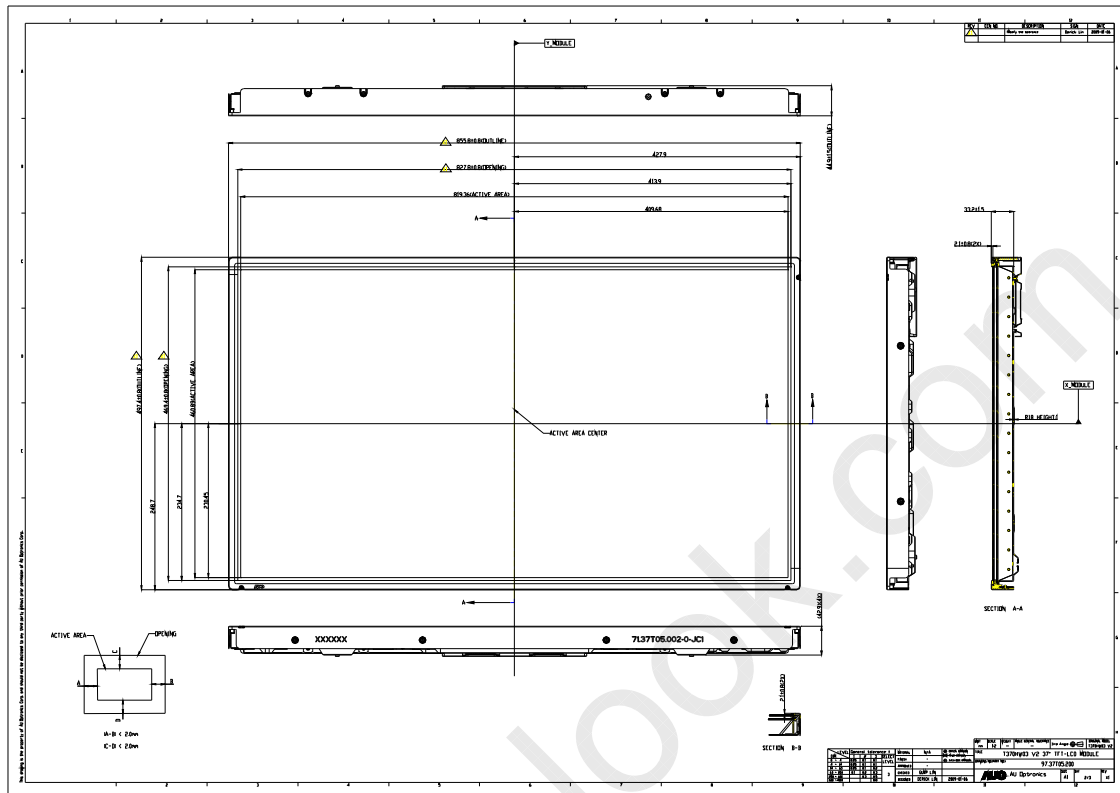

©Copyright AU Optronics, Inc.
 April, 2008 All Rights Reserved.
 No Reproduction and Redistribution Allowed

T370HW03 V2

25/30



6. Reliability

Environment test condition:

No	Test Item	Condition
1	High temperature storage test	Ta=60°C, 300hr
2	Low temperature storage test	Ta=-20°C, 300hr
3	Temperature humidity bias test	Ta=50°C, 80%RH, 300hr
4	High temperature operation test	Ta=50°C, 300hr
5	Low temperature operation test	Ta=0°C, 300hr
6	Vibration test (non-operating)	(10 ~ 300Hz/1.5G/11min SR, XYZ 30min/axis) Vibration level : 1.5G RMS, Bandwidth : 10-300Hz Duration: X, Y, Z 30min one time each direction
7	Shock test (non-operating)	Shock level: 50G Waveform: half sine wave, 11ms Direction: ±X, ±Y, ±Z One time each direction
8	Vibration test (with carton)	Random wave (1.5Grms 10~200Hz) 30mins / Per each X.Y.Z axes
9	Drop test (with carton)	Height: 30.5 cm 1 corner, 3 edges, 6 surfaces (ASTMD4169-I)



7. International Standard

7-1 Safety

- (1) UL1950 Third Edition, Underwriters Laboratories, Inc. Jan. 28, 1995
Standard for Safety of Information Technology Equipment Including electrical Business Equipment.
- (2) CAN/CSA C22.2 No. 950-95/60950 Third Edition, Canadian Standards Association,
Standard for Safety of Information Technology Equipment Including Electrical Business Equipment.
- (3) EN60950: 1992+A2: 1993+A2: 1993+C3: 1995+A4: 1997+A11: 1997
IEC 950: 1991+A1: 1992+A2: 1993+C3: 1995+A4:1996
IEC 60065 : vision 7.0
European Committee for Electrotechnical Standardization (CENELEC)
EUROPEAN STANDARD for Safety of Information Technology Equipment Including Electrical Business Equipment.

7-2 EMC

- a) ANSI C63.4 “Methods of Measurement of Radio-Noise Emissions from Low-Voltage Electrical and Electrical Equipment in the Range of 9kHz to 40GHz. “American National standards Institute(ANSI), 1992
- b) C.I.S.P.R “Limits and Methods of Measurement of Radio Interface Characteristics of Information Technology Equipment.” International Special committee on Radio Interference.
- c) EN 55022 “Limits and Methods of Measurement of Radio Interface Characteristics of Information Technology Equipment.” European Committee for Electrotechnical Standardization. (CENELEC), 1998



8. Packing

A. Panel Label:



TW8601400099-PM0200

TW: T: Taiwan, A/B: China

00099: Panel Serial Number

PM: AUO internal code

B. Carton Label:

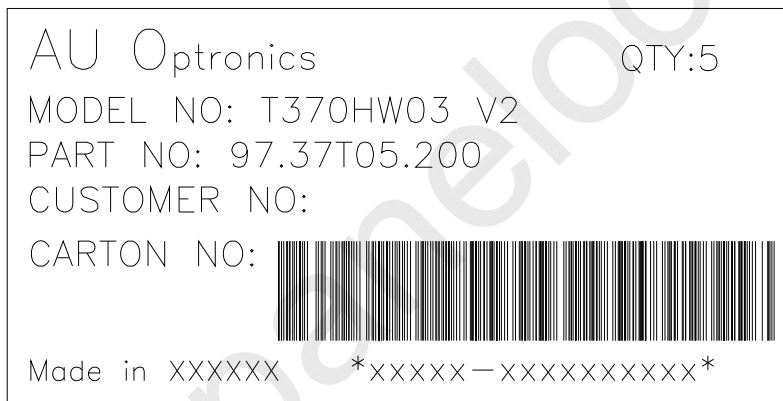



PACKING METHODS:

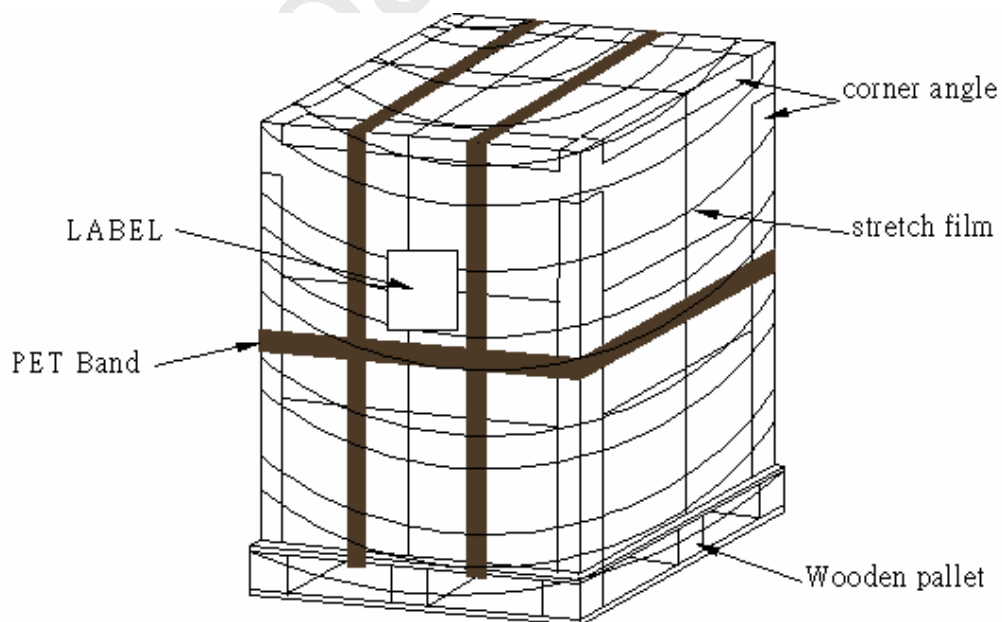
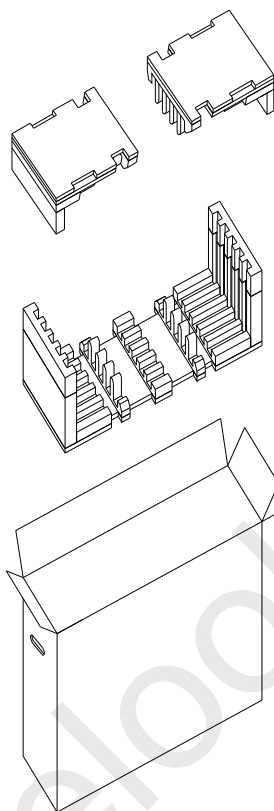

©Copyright AU Optronics, Inc.
April, 2008 All Rights Reserved.
No Reproduction and Redistribution Allowed

T370HW03 V2

29/31



Packing Specification:

	Item	Specification			Packing Remark
		Qty.	Dimension	Weight (kg)	
1	Packing BOX	5 pcs/box	900(L)mm*375(W)mm*610(H)mm	45	
2	Pallet	1	1150(L)mm*910(W)mm*140(H)mm	15	
3	Boxes per Pallet	6 boxes/Pallet (By Air) ; 9 boxes/Pallet (By Sea)			
4	Panels per Pallet	30 pcs/pallet(By Air) ; 45 pcs/Pallet (By Sea)			
	Pallet after packing	30 (by Air) 45 (by Sea)	1150(L)mm*910(W)mm*1496(H)mm (by Air) 1150(L)mm*910(W)mm*2244(H)mm (by Sea)	336 (by Air) 506(by Sea, 40ft HQ)	



9. PRECAUTIONS

Please pay attention to the followings when you use this TFT LCD module.

9-1 MOUNTING PRECAUTIONS

- (1) You must mount a module using holes arranged in four corners or four sides.
- (2) You should consider the mounting structure so that uneven force (ex. Twisted stress) is not applied to module. And the case on which a module is mounted should have sufficient strength so that external force is not transmitted directly to the module.
- (3) Please attach the surface transparent protective plate to the surface in order to protect the polarizer. Transparent protective plate should have sufficient strength in order to resist external force.
- (4) You should adopt radiation structure to satisfy the temperature specification.
- (5) Acetic acid type and chlorine type materials for the cover case are not desirable because the former generates corrosive gas of attacking the polarizer at high temperature and the latter causes circuit break by electro-chemical reaction.
- (6) Do not touch, push or rub the exposed polarizer with glass, tweezers or anything harder than HB pencil lead. And please do not rub with dust clothes with chemical treatment. Do not touch the surface of polarizer for bare hand or greasy cloth. (Some cosmetics are detrimental to the polarizer.)
- (7) When the surface becomes dusty, please wipe gently with absorbent cotton or other soft materials like chamois soaks with petroleum benzene. Normal-hexane is recommended for cleaning the adhesives used to attach front/ rear polarizer. Do not use acetone, toluene and alcohol because they cause chemical damage to the polarizer.
- (8) Wipe off saliva or water drops as soon as possible. Their long time contact with polarizer causes deformations and color fading.
- (9) Do not open the case because inside circuits do not have sufficient strength.

9-2 OPERATING PRECAUTIONS

- (1) The device listed in the product specification sheets was designed and manufactured for TV application
- (2) The spike noise causes the mis-operation of circuits. It should be lower than following voltage: $V=\pm 200\text{mV}$ (Over and under shoot voltage)
- (3) Response time depends on the temperature. (In lower temperature, it becomes longer.)
- (4) Brightness of CCFL depends on the temperature. (In lower temperature, it becomes lower.) And in lower temperature, response time (required time that brightness is stable after turned on) becomes longer.
- (5) Be careful for condensation at sudden temperature change. Condensation makes damage to polarizer or electrical contacted parts. And after fading condensation, smear or spot will occur.
- (6) When fixed patterns are displayed for a long time, remnant image is likely to occur.
- (7) Module has high frequency circuits. Sufficient suppression to the electromagnetic interference shall be done by system manufacturers. Grounding and shielding methods may be important to minimize the interface.



9-3 ELECTROSTATIC DISCHARGE CONTROL

Since a module is composed of electronic circuits, it is not strong to electrostatic discharge. Make certain that treatment persons are connected to ground through wristband etc. And don't touch interface pin directly.

9-4 PRECAUTIONS FOR STRONG LIGHT EXPOSURE

Strong light exposure causes degradation of polarizer and color filter.

9-5 STORAGE

When storing modules as spares for a long time, the following precautions are necessary.

- (1) Store them in a dark place. Do not expose the module to sunlight or fluorescent light. Keep the temperature between 5°C and 35°C at normal humidity.
- (2) The polarizer surface should not come in contact with any other object. It is recommended that they be stored in the container in which they were shipped.

9-6 HANDLING PRECAUTIONS FOR PROTECTION FILM

- (1) The protection film is attached to the bezel with a small masking tape. When the protection film is peeled off, static electricity is generated between the film and polarizer. This should be peeled off slowly and carefully by people who are electrically grounded and with well ion-blown equipment or in such a condition, etc.
- (2) When the module with protection film attached is stored for a long time, sometimes there remains a very small amount of flue still on the Bezel after the protection film is peeled off.
- (3) You can remove the glue easily. When the glue remains on the Bezel or its vestige is recognized, please wipe them off with absorbent cotton waste or other soft material like chamois soaked with normal-hexane.



Appendix :

1. Deep (10%) dimming life time

Deep (10%) dimming life-time

The life-time of bare lamp can meet 50,000 hours under ambient temperature 25°C and PWM waveform as shown below.

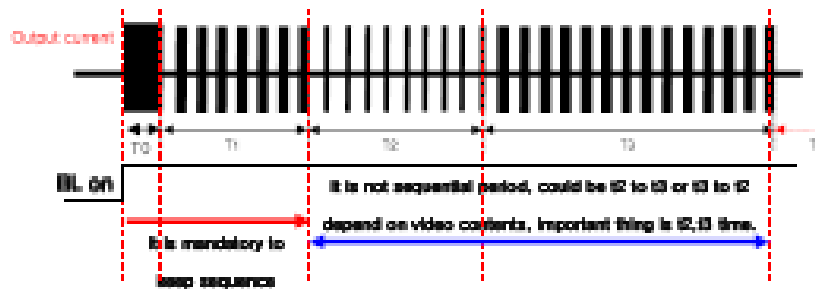

Parameter	Value			Unit	Note
	Min	Typ	Max		
T0	2	-	-	sec	100% No dimming
T1	3	-	-	min	PWM duty 20~ 100%
T2	-	-	10	min	PWM duty 10~ 100%
T3	T2*5	-	-	min	PWM duty 20~ 100%

Note:

1. BL operation condition follow current AUO product specification as item 4 and 5. Please refer to each product specification.
2. For IPB application, flicker or lamp striking instability should be prevented. Especially for deep dimming occasion.
3. The rapid change of lamp surface temperature could induce luminance instability due to dynamic dimming application.
4. AUO can guarantee the uniformity and flicker above 20% dimming condition.
5. 10% dimming function is okay (panel operation temperature min 0°C, max 50°C).