

# Model Name: T370HW05 V0

Issue Date : 2010/11/11

( ) Preliminary Specifications

(\* ) Final Specifications

Customer Signature	Date	AUO	Date
Approved By ANDO SHIGEO <i>Shigeo Ando</i>	14th. Jan. 2011	Approval By PM Director Yen Ting Chiu <i>YTC</i>	2010/12/19
Note		Reviewed By RD Director Eugene CC Chen <i>Eugene Chen</i>	2010 8/8
		Reviewed By Project Leader SK Hsu <i>SK Hsu</i>	
		Prepared By PM Eric YH Lin <i>Eric Lin</i>	1/59

## Contents

No		
		CONTENTS
		RECORD OF REVISIONS
1		GENERAL DESCRIPTION
2		ABSOLUTE MAXIMUM RATINGS
3		ELECTRICAL SPECIFICATION
	3-1	ELECTRICAL CHARACTERISTICS
	3-2	INTERFACE CONNECTIONS
	3-3	SIGNAL TIMING SPECIFICATION
	3-4	SIGNAL TIMING WAVEFORM
	3-5	COLOR INPUT DATA REFERENCE
	3-6	POWER SEQUENCE
	3-7	BACKLIGHT SPECIFICATION
4		OPTICAL SPECIFICATION
5		MECHANICAL CHARACTERISTICS
6		RELIABILITY TEST ITEMS
7		INTERNATIONAL STANDARD
	7-1	SAFETY
	7-2	EMC
8		PACKING
	8-1	DEFINITION OF LABEL
	8-2	PACKING METHODS
	8-3	PALLET AND SHIPMENT INFORMATION
9		PRECAUTION
	9-1	MOUNTING PRECAUTIONS
	9-2	OPERATING PRECAUTIONS
	9-3	ELECTROSTATIC DISCHARGE CONTROL
	9-4	PRECAUTIONS FOR STRONG LIGHT EXPOSURE
	9-5	STORAGE
	9-6	HANDLING PRECAUTIONS FOR PROTECT FILM



## 1. General Description

This specification applies to the 37.0 inch Color TFT-LCD Module T370HW05 V0. This LCD module has a TFT active matrix type liquid crystal panel 1,920x1,080 pixels, and diagonal size of 37.0 inch. This module supports 1,920x1,080 mode. Each pixel is divided into Red, Green and Blue sub-pixels or dots which are arranged in vertical stripes. Gray scale or the brightness of the sub-pixel color is determined with a 10-bit gray scale signal for each dot.

The T370HW05 V0 has been designed to apply the 10-bit 2 channel LVDS interface method. It is intended to support displays where high brightness, wide viewing angle, high color saturation, and high color depth are very important.

### \* General Information

Items	Specification	Unit	Note
Active Screen Size	37.00	inch	
Display Area	819.36(H) x 460.89(V)	mm	
Outline Dimension	856.4(H) x 501.0 (V) x 10.8(D)	mm	
Driver Element	a-Si TFT active matrix		
Bezel Opening	826.4 (H) x 468 (V)	mm	
Display Colors	10 bit, 1.07G	Colors	
Number of Pixels	1,920x1,080	Pixel	
Pixel Pitch	0.4268 (H) x 0.4268(W)	mm	
Pixel Arrangement	RGB vertical stripe		
Display Operation Mode	Normally Black		
Surface Treatment	Anti-Glare, 3H		Haze=2%

## 2. Absolute Maximum Ratings

The followings are maximum values which, if exceeded, may cause faulty operation or damage to the unit

Item	Symbol	Min	Max	Unit	Conditions
Logic/LCD Drive Voltage	Vcc	-0.3	14	[Volt]	Note 1
Input Voltage of Signal	Vin	-0.3	4	[Volt]	Note 1
Operating Temperature	TOP	0	+50	[°C]	Note 2
Operating Humidity	HOP	10	90	[%RH]	Note 2
Storage Temperature	TST	-20	+60	[°C]	Note 2
Storage Humidity	HST	10	90	[%RH]	Note 2
Panel Surface Temperature	PST		65	[°C]	Note 3

Note 1: Duration:50 msec.

Note 2 : Maximum Wet-Bulb should be 39°C and No condensation.

The relative humidity must not exceed 90% non-condensing at temperatures of 40°C or less. At temperatures greater than 40°C, the wet bulb temperature must not exceed 39°C.

Note 3: Surface temperature is measured at 50°C Dry condition

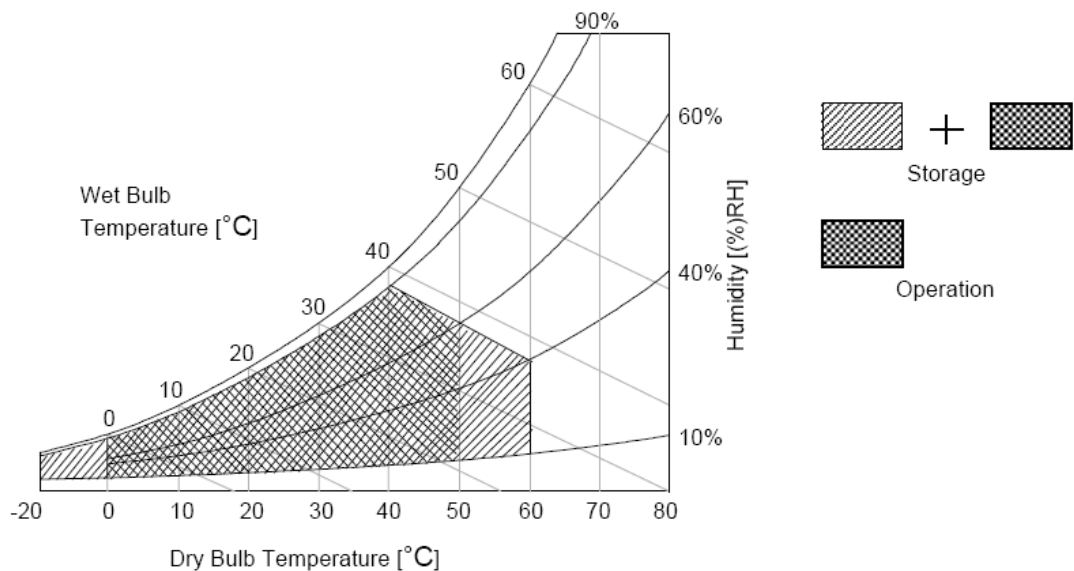

### 3. Electrical Specification

The T370HW05 V0 requires two power inputs. One is employed to power the LCD electronics and to drive the TFT array and liquid crystal. The second input for BLU is to power inverter.

#### 3.1 Electrical Characteristics

##### 3.1.1: DC Characteristics

Parameter		Symbol	Value			Unit	Note
			Min.	Typ.	Max		
LCD							
Power Supply Input Voltage		$V_{DD}$	10.8	12	13.2	$V_{DC}$	
Power Supply Input Current		$I_{DD}$	--	0.85	1	A	1
Power Consumption		$P_C$	--	10.2	13.2	Watt	1
Inrush Current		$I_{RUSH}$	--	--	4	A	2
LVDS Interface	Input Differential Voltage	$ V_{ID} $	200	400	600	$mV_{DC}$	3
	Differential Input High Threshold Voltage	$V_{TH}$	+100	--	+300	$mV_{DC}$	3
	Differential Input Low Threshold Voltage	$V_{TL}$	-300	--	-100	$mV_{DC}$	3
	Input Common Mode Voltage	$V_{ICM}$	1.1	1.25	1.4	$V_{DC}$	3

### 3.1.2: AC Characteristics

Parameter		Symbol	Value			Unit	Note
			Min.	Typ.	Max		
LVDS Interface	Input Channel Pair Skew Margin	$t_{\text{SKEW (CP)}}$	-500	--	+500	ps	5
	Receiver Clock : Spread Spectrum Modulation range	Fclk_ss	Fclk -3%	--	Fclk +3%	MHz	6
	Receiver Clock : Spread Spectrum Modulation frequency	Fss	30	--	200	KHz	6
	Receiver Data Input Margin Fclk = 85 MHz Fclk = 65 MHz	tRMG	-0.4 -0.5	-- --	0.4 0.5	ns	7

**Note :**

- $V_{\text{DD}} = 12.0\text{V}$ ,  $F_v = 60\text{Hz}$ ,  $F_{\text{clk}} = 82\text{MHz}$ ,  $25^\circ\text{C}$ , Test Pattern : White Pattern  
>> refer to "Section:3.3 Signal Timing Specification, Typical timing"
- Measurement condition : Rising time = 400us

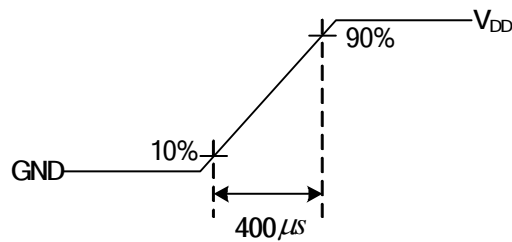

- $V_{\text{ICM}} = 1.25\text{V}$

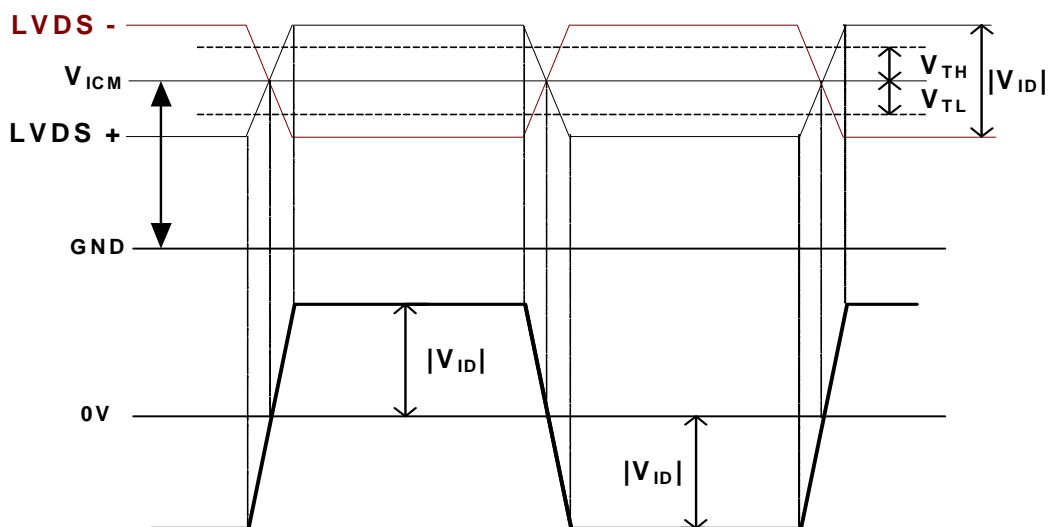

4. The measure points of  $V_{IH}$  and  $V_{IL}$  are in LCM side after connecting the System Board and LCM.
5. Input Channel Pair Skew Margin

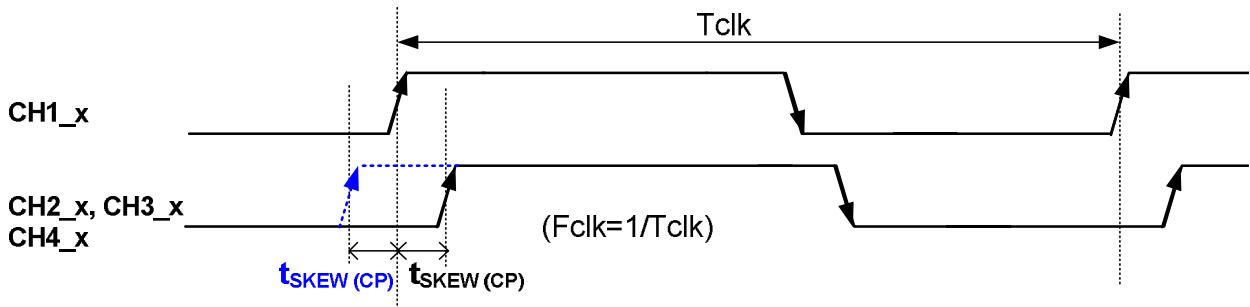

Note:  $x = 0, 1, 2, 3, 4$

6. LVDS Receiver Clock SSCG (Spread spectrum clock generator) is defined as below figures

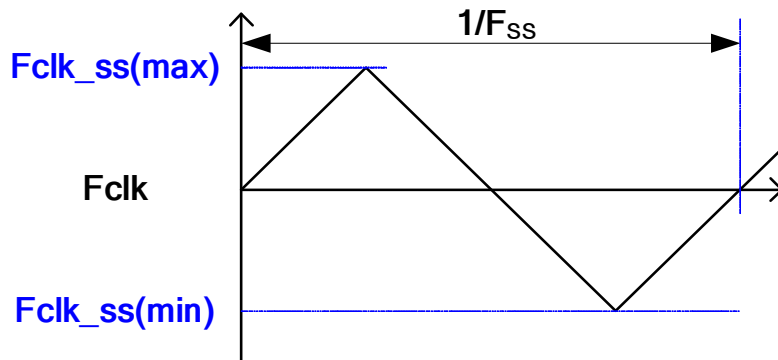



7. Receiver Data Input Margin

Parameter	Symbol	Rating			Unit	Note
		Min	Type	Max		
Input Clock Frequency	Fclk	Fclk (min)	--	Fclk (max)	MHz	$T=1/Fclk$
Input Data Position0	tRIP1	- tRMG	0	tRMG	ns	
Input Data Position1	tRIP0	$T/7- tRMG $	$T/7$	$T/7+ tRMG $	ns	
Input Data Position2	tRIP6	$2T/7- tRMG $	$2T/7$	$2T/7+ tRMG $	ns	
Input Data Position3	tRIP5	$3T/7- tRMG $	$3T/7$	$3T/7+ tRMG $	ns	
Input Data Position4	tRIP4	$4T/7- tRMG $	$4T/7$	$4T/7+ tRMG $	ns	
Input Data Position5	tRIP3	$5T/7- tRMG $	$5T/7$	$5T/7+ tRMG $	ns	
Input Data Position6	tRIP2	$6T/7- tRMG $	$6T/7$	$6T/7+ tRMG $	ns	

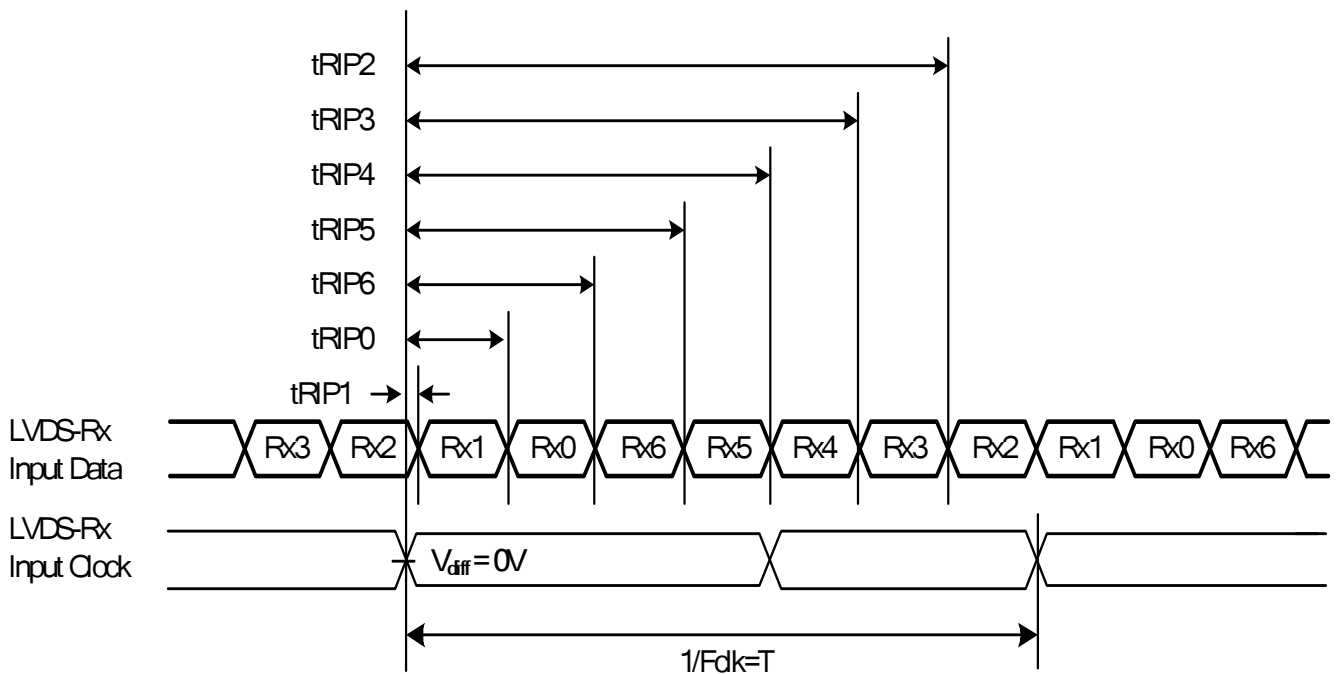

### 3.2 Interface Connections

- LCD connector: FI-RE51S-HF (JAE, LVDS connector)
- Mating connector:

Pin No		12V 51Pin
1	VCC	Operating Voltage Supply, +12V DC Regulated
2	VCC	Operating Voltage Supply, +12V DC Regulated
3	VCC	Operating Voltage Supply, +12V DC Regulated
4	VCC	Operating Voltage Supply, +12V DC Regulated
5	VCC	Operating Voltage Supply, +12V DC Regulated
6	NC	No Connect (Open : Inside of panel)
7	GND	Ground
8	GND	Ground
9	GND	Ground
10	RO[0]N	LVDS Channel Odd, Signal 0-
11	RO[0]P	LVDS Channel Odd, Signal 0+
12	RO[1]N	LVDS Channel Odd, Signal 1-
13	RO[1]P	LVDS Channel Odd, Signal 1+
14	RO[2]N	LVDS Channel Odd, Signal 2-
15	RO[2]P	LVDS Channel Odd, Signal 2+
16	GND	Ground
17	ROCLK-	LVDS Channel Odd, Clock -
18	ROCLK+	LVDS Channel Odd, Clock +
19	GND	Ground
20	RO[3]N	LVDS Channel Odd, Signal 3-
21	RO[3]P	LVDS Channel Odd, Signal 3+
22	RO[4]N	LVDS Channel Odd, Signal 4-(for 10bit input) If 8bit input, please keep NC
23	RO[4]P	LVDS Channel Odd, Signal 4+(for 10bit input) If 8bit input, please keep NC
24	GND	Ground
25	RE[0]N	LVDS Channel Even, Signal 0-

26	RE[0]P	LVDS Channel Even, Signal 0+
27	RE[1]N	LVDS Channel Even, Signal 1-
28	RE[1]P	LVDS Channel Even, Signal 1+
29	RE[2]N	LVDS Channel Even, Signal 2-
30	RE[2]P	LVDS Channel Even, Signal 2+
31	GND	Ground
32	RECLK-	LVDS Channel Even, Clock -
33	RECLK+	LVDS Channel Even, Clock +
34	GND	Ground
35	RE[3]N	LVDS Channel Even, Signal 3-
36	RE[3]P	LVDS Channel Even, Signal 3+
37	RE[4]N	LVDS Channel Even, Signal 4-(for 10bit input) If 8bit input, please keep NC
38	RE[4]P	LVDS Channel Even, Signal 4+(for 10bit input) If 8bit input, please keep NC
39	GND	Ground
40	SCL	EEPROM Serial Clock
41	SDA	EEPROM Serial Data
42	SONY Reserved	No connection(Open: Inside of panel)
43	B_INT(WP)	EEPROM Write Protection High(3.3V) for Writable, Low(GND) for Protection
44	PANEL_SEL	Panel_SEL
45	LVDS_SEL	Open/High(3.3V) for NS, Low(GND) for JEIDA
46	NC	No connection(Open: Inside of panel)
47	NC	No connection(Open: Inside of panel)
48	NC	No connection(Open: Inside of panel)
49	SONY Reserved	No connection(Open: Inside of panel)
50	NC	No connection(Open: Inside of panel)
51	NC	No connection(Open: Inside of panel)

**LVDS Option = High/Open→NS**

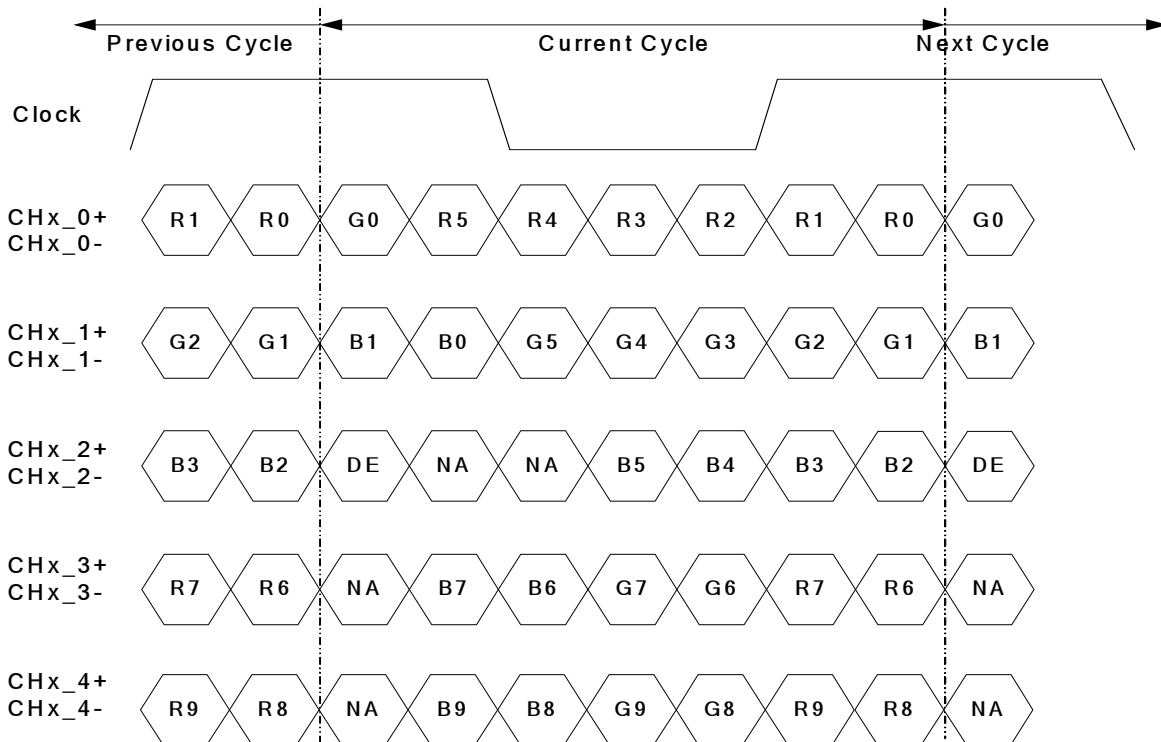

Note: x = 1, 2, 3, 4...

**LVDS Option = Low→JEIDA**

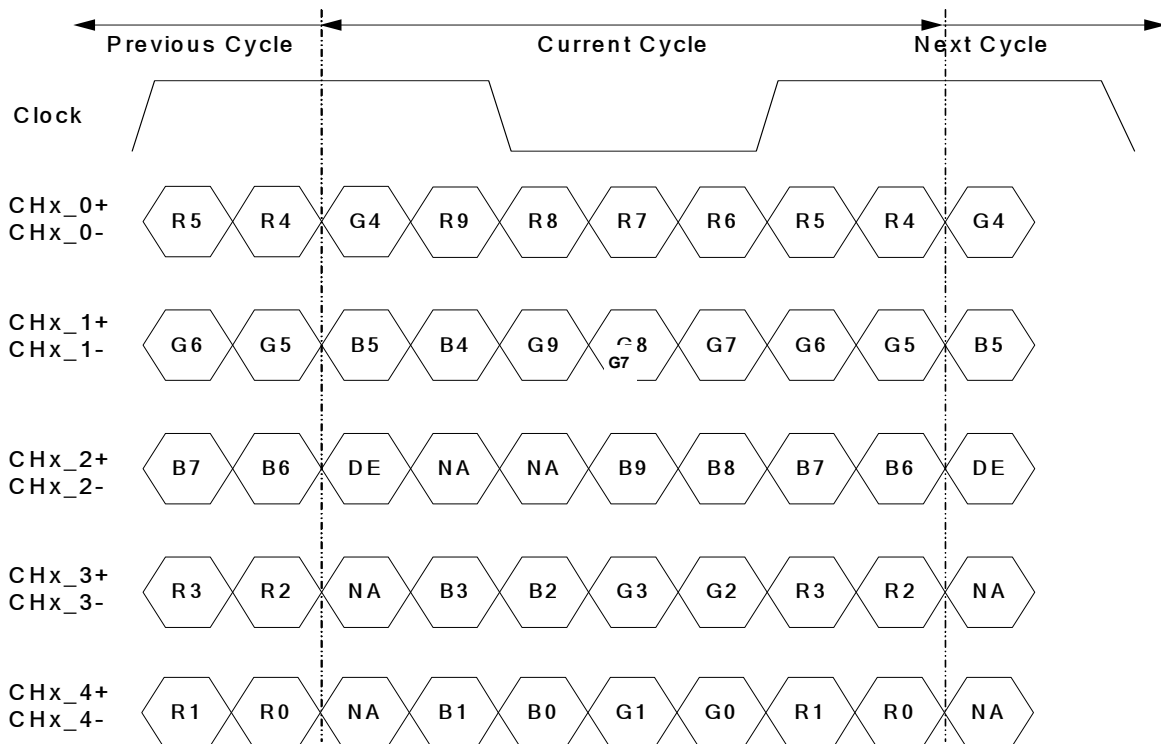

Note: x = 1, 2, 3, 4...

### 3.3 Signal Timing Specification

This is the signal timing required at the input of the user connector. All of the interface signal timing should be satisfied with the following specifications for its proper operation.

#### 1920x1080x50Hz/60Hz

#### Timing Table (DE only Mode)

Signal	Item	Symbol	Min.	Typ.	Max	Unit
Vertical Section	Period	Tv	1090	1125	1480	Th
	Active	Tdisp (v)	1080			Th
	Blanking	Tblk (v)	10	45	400	Th
Horizontal Section	Period	Th	1030	1100	1325	Tclk
	Active	Tdisp (h)	960			Tclk
	Blanking	Tblk (h)	70	140	365	Tclk
Clock	Frequency	Fclk=1/Tclk	50	74.25	82	MHz
Vertical Frequency	Frequency	Fv	47	60	63	Hz
Horizontal Frequency	Frequency	Fh	60	67.5	73	KHz

Notes:

(1) Display position is specific by the rise of DE signal only.

Horizontal display position is specified by the rising edge of 1<sup>st</sup> DCLK after the rise of 1<sup>st</sup> DE, is displayed on the left edge of the screen.

(2) Vertical display position is specified by the rise of DE after a "Low" level period equivalent to eight times of horizontal period. The 1<sup>st</sup> data corresponding to one horizontal line after the rise of 1<sup>st</sup> DE is displayed at the top line of screen.

(3) If a period of DE "High" is less than 1920 DCLK or less than 1080 lines, the rest of the screen displays black.

(4) The display position does not fit to the screen if a period of DE "High" and the effective data period do not synchronize with each other.

## 3.4 Signal Timing Waveforms 1920x1080x60Hz

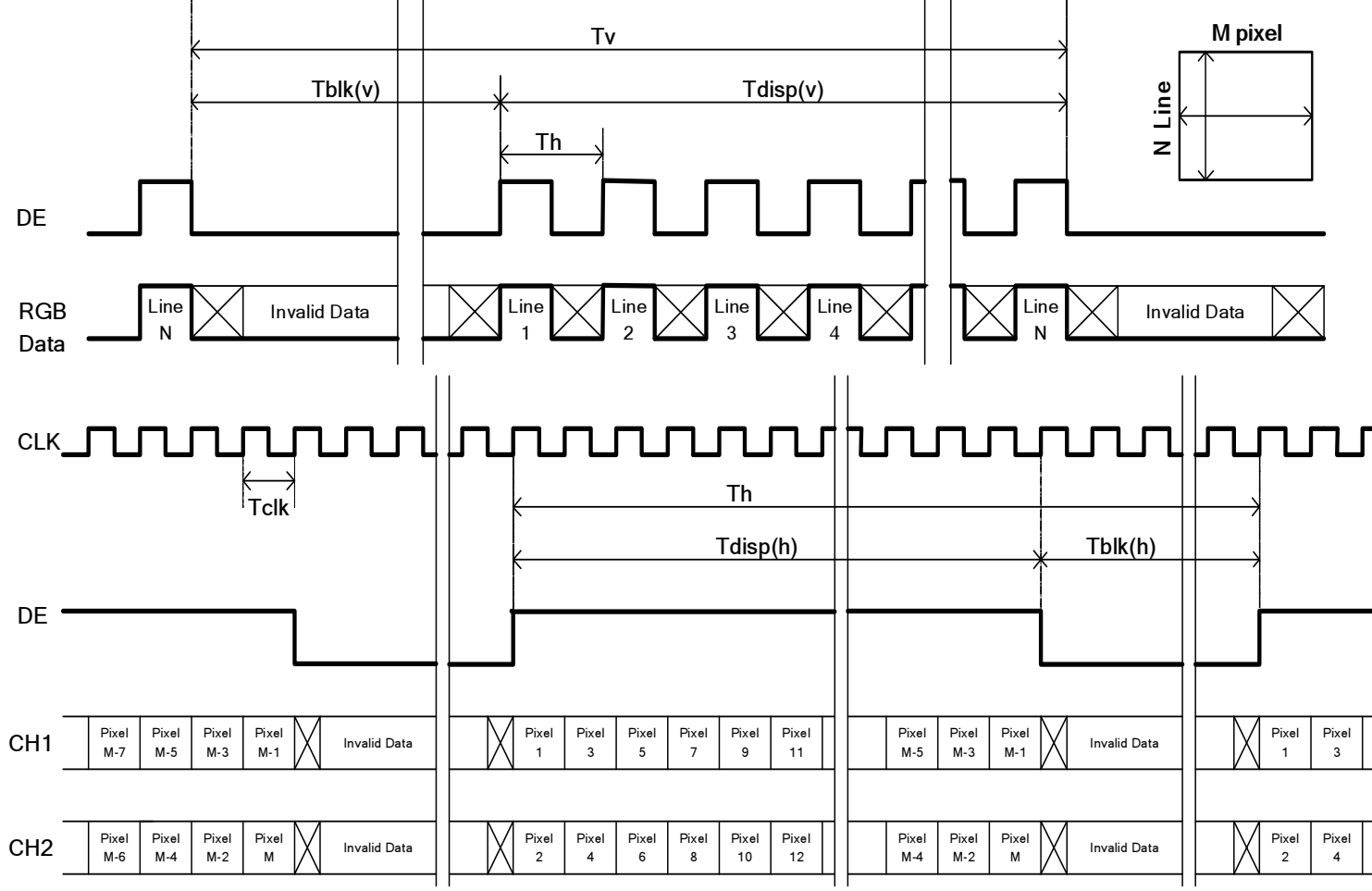

### 3.5 Color Input Data Reference (LVDS Option for 10bit)

The brightness of each primary color (red, green and blue) is based on the 10 bit gray scale data input for the color; the higher the binary input, the brighter the color. The table below provides a reference for color versus data input.

#### COLOR DATA REFERENCE

Color		Input Color Data																											
		RED										GREEN										BLUE							
		MSB					LSB					MSB					LSB					MSB			LSB				
		R9	R8	R7	R6	R5	R4	R3	R2	R1	R0	G9	G8	G7	G6	G5	G4	G3	G2	G1	G0	B9	B8	B7	B6	B5	B4	B3	B2
Basic Color	Black	0	0	0	0	0	0	0	0	0	0	0	0	0	0	0	0	0	0	0	0	0	0	0	0	0	0	0	
	Red(1023)	1	1	1	1	1	1	1	1	1	0	0	0	0	0	0	0	0	0	0	0	0	0	0	0	0	0	0	
	Green(1023)	0	0	0	0	0	0	0	0	0	1	1	1	1	1	1	1	1	1	1	0	0	0	0	0	0	0	0	
	Blue(1023)	0	0	0	0	0	0	0	0	0	0	0	0	0	0	0	0	0	0	0	1	1	1	1	1	1	1	1	
	Cyan	0	0	0	0	0	0	0	0	0	1	1	1	1	1	1	1	1	1	1	1	1	1	1	1	1	1	1	
	Magenta	1	1	1	1	1	1	1	1	1	0	0	0	0	0	0	0	0	0	0	1	1	1	1	1	1	1	1	
	Yellow	1	1	1	1	1	1	1	1	1	1	1	1	1	1	1	1	1	1	1	0	0	0	0	0	0	0	0	
	White	1	1	1	1	1	1	1	1	1	1	1	1	1	1	1	1	1	1	1	1	1	1	1	1	1	1	1	
R	RED(000)	0	0	0	0	0	0	0	0	0	0	0	0	0	0	0	0	0	0	0	0	0	0	0	0	0	0		
	RED(001)	0	0	0	0	0	0	0	0	1	0	0	0	0	0	0	0	0	0	0	0	0	0	0	0	0	0		
	----																												
	RED(1022)	1	1	1	1	1	1	1	1	0	0	0	0	0	0	0	0	0	0	0	0	0	0	0	0	0	0		
	RED(1023)	1	1	1	1	1	1	1	1	1	0	0	0	0	0	0	0	0	0	0	0	0	0	0	0	0	0		
G	GREEN(000)	0	0	0	0	0	0	0	0	0	0	0	0	0	0	0	0	0	0	0	0	0	0	0	0	0	0		
	GREEN(001)	0	0	0	0	0	0	0	0	0	0	0	0	0	0	0	0	0	1	0	0	0	0	0	0	0	0		
	----																												
	GREEN(1022)	0	0	0	0	0	0	0	0	0	1	1	1	1	1	1	1	1	0	0	0	0	0	0	0	0	0		
	GREEN(1023)	0	0	0	0	0	0	0	0	0	1	1	1	1	1	1	1	1	1	0	0	0	0	0	0	0	0		
B	BLUE(000)	0	0	0	0	0	0	0	0	0	0	0	0	0	0	0	0	0	0	0	0	0	0	0	0	0	0		
	BLUE(001)	0	0	0	0	0	0	0	0	0	0	0	0	0	0	0	0	0	0	0	0	0	0	0	0	0	1		
	----																												
	BLUE(1022)	0	0	0	0	0	0	0	0	0	0	0	0	0	0	0	0	0	0	1	1	1	1	1	1	1	0		
	BLUE(1023)	0	0	0	0	0	0	0	0	0	0	0	0	0	0	0	0	0	0	1	1	1	1	1	1	1	1		

### 3.6 Power Sequence for LCD Sony specification 1920x1080x60Hz

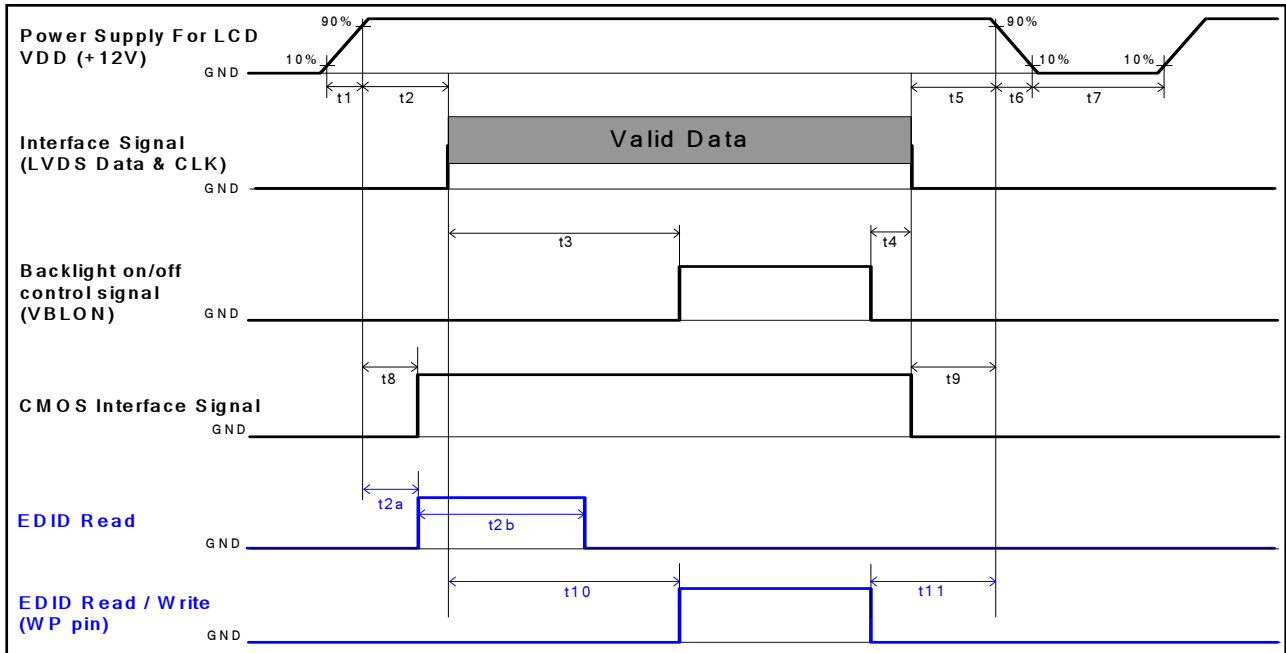

Parameter	Values			Unit
	Min.	Type.	Max.	
t1	0.4	---	30	ms
t2	0.1	---	50	ms
t3	450	---	---	ms
t4	0 <sup>*1</sup>	---	---	ms
t5	0	---	---	ms
t6	---	---	--- <sup>*2</sup>	ms
t7	500	---	---	ms
t8	10	---	50	ms
t9	0	---	---	ms
t10	450	---	---	ms
t11	150	---	---	ms
t2a	10	---	100	ms
t2b	0	---	100	ms

Note:

(1) t4=0 : concern for residual pattern before BLU turn off.

(2) t6 : voltage of VDD must decay smoothly after power-off. (customer system decide this value)



### 3.7 Backlight Specification

The backlight unit contains 2 pcs light bar.

#### 3.7.1 Light bar Driven Condition

Parameter		Symbol	Values			Unit	Note
			Min	Typ	Max		
Forward Current (one light bar)	Anode	IF (anode)		120		mA	
	Cathode	IF (cathode)		120	126	mA	
Peak Forward Current		IFP			500	mA	<1msec.
Forward Voltage		VF	144	163.2	172.8	V	Ta=25°C
Forward Voltage Variation		ΔVF			1.8	V	
Total Power Consumption (2 light bars)		PBL	34.5	39.2	42.5	W	

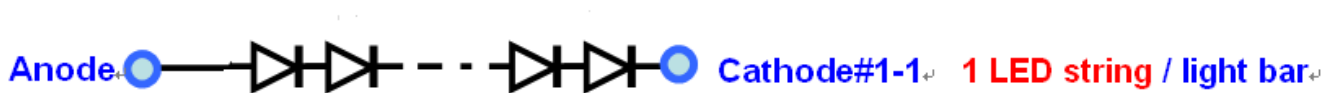

### 3.7.2 Input Pin Assignment

	P1 -4pin		P2 - 5pin
1	#1 Anode	1	#1 Cathode (120mA)
2	NC	2	NC
3	#2 Anode	3	#2 Cathode (120mA)
4	NC	4	NC
		5	NC

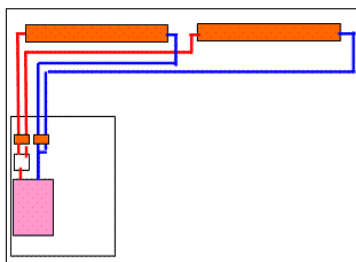

32"/37"/40" 1 top  
(=opposite side of source PCB)  
→2 parallel system

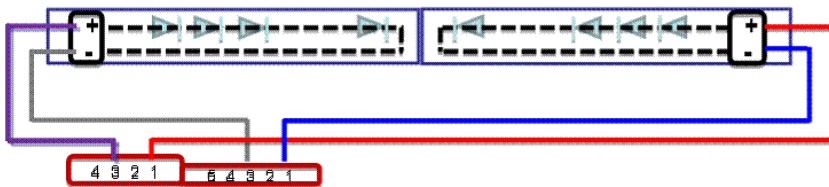

Morex  
4PIN+側電源(#1.#3)  
51103-0400  
5PIN-側電源(#1.#3)  
51103-0500

## 4. Optical Specification

Optical characteristics are determined after the unit has been 'ON' and stable for approximately 45 minutes in a dark environment at 25°C. The values specified are at an approximate distance 50cm from the LCD surface at a viewing angle of  $\varphi$  and  $\theta$  equal to 0°.

Fig.1 presents additional information concerning the measurement equipment and method.

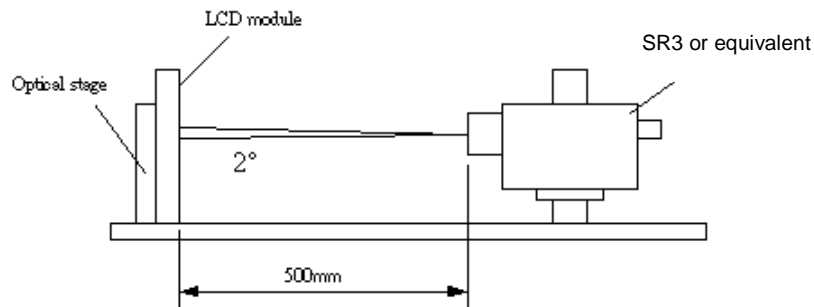

Parameter	Symbol	Values			Unit	Notes
		Min.	Typ.	Max		
Contrast Ratio	CR	3200	4000	--		1
Surface Luminance (White)	L <sub>WH</sub>	320	400	--	cd/m <sup>2</sup>	2
Luminance Variation	$\delta_{\text{WHITE}(9P)}$	--	--	1.3		3
Response Time (G to G)	T <sub>γ</sub>	--	8	--	Ms	4
Color Gamut	NTSC		72		%	
Color Coordinates						
	Red	R <sub>x</sub>	Typ.-0.03	0.630	Typ.+0.03	
		R <sub>y</sub>		0.330		
	Green	G <sub>x</sub>		0.320		
		G <sub>y</sub>		0.620		
	Blue	B <sub>x</sub>		0.150		
		B <sub>y</sub>		0.040		
	White	W <sub>x</sub>		0.280		
	W <sub>y</sub>	0.290				
Viewing Angle						
	x axis, right( $\varphi=0^\circ$ )	$\theta_r$	--	89	--	degree
	x axis, left( $\varphi=180^\circ$ )	$\theta_l$	--	89	--	degree
	y axis, up( $\varphi=90^\circ$ )	$\theta_u$	--	89	--	degree
	y axis, down ( $\varphi=270^\circ$ )	$\theta_d$	--	89	--	degree

Note:

1. Contrast Ratio (CR) is defined mathematically as:

$$\text{Contrast Ratio} = \frac{\text{Surface Luminance of } L_{on5}}{\text{Surface Luminance of } L_{off5}}$$

2. Surface luminance is luminance value at point 5 across the LCD surface 50cm from the surface with all pixels displaying white. From more information see FIG 2. When LED current  $I_H = 120\text{mA}$ .  $L_{WH} = L_{on5}$  where  $L_{on5}$  is the luminance with all pixels displaying white at center 5 location.

3. The variation in surface luminance,  $\delta_{WHITE}$  is defined (center of Screen) as:

$$\delta_{WHITE(9P)} = \text{Maximum}(L_{on1}, L_{on2}, \dots, L_{on9}) / \text{Minimum}(L_{on1}, L_{on2}, \dots, L_{on9})$$

4. Response time  $T_\gamma$  is the average time required for display transition by switching the input signal for five luminance ratio (0%,25%,50%,75%,100% brightness matrix) and is based on  $F_v=60\text{Hz}$  to optimize.

Measured Response Time		Target				
		0%	25%	50%	75%	100%
Start	0%		0% to 25%	0% to 50%	0% to 75%	0% to 100%
	25%	25% to 0%		25% to 50%	25% to 75%	25% to 100%
	50%	50% to 0%	50% to 25%		50% to 75%	50% to 100%
	75%	75% to 0%	75% to 25%	75% to 50%		75% to 100%
	100%	100% to 0%	100% to 25%	100% to 50%	100% to 75%	

The response time is defined as the following figure and shall be measured by switching the input signal for “any level of gray(bright)” and “any level of gray(dark)”.

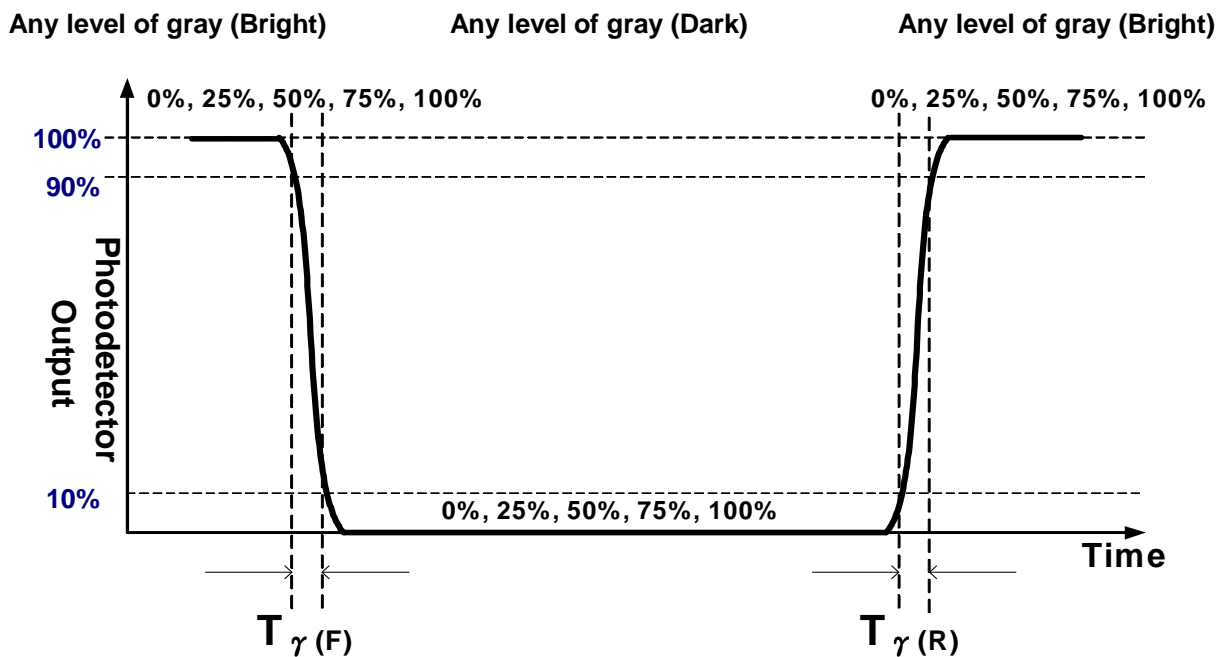
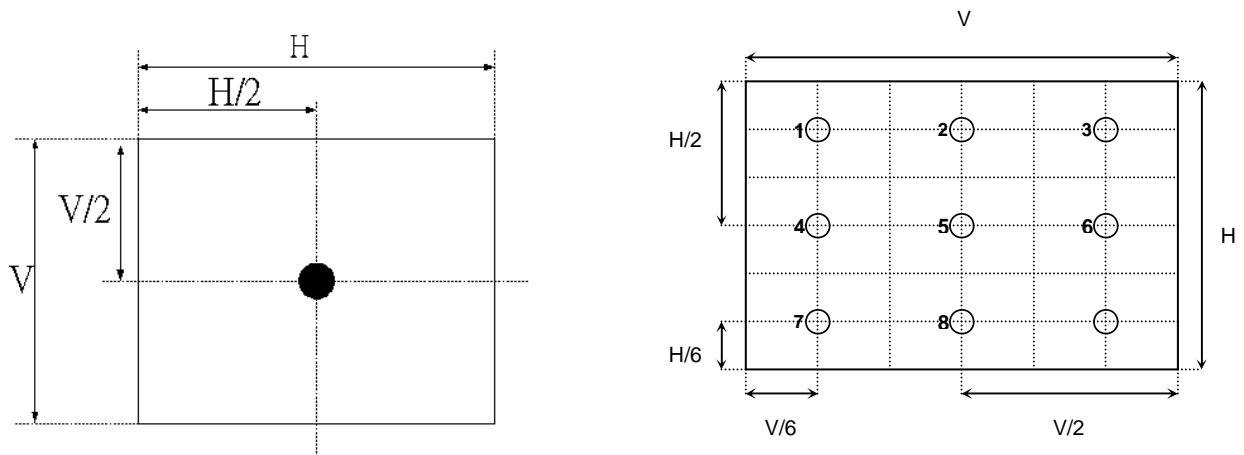
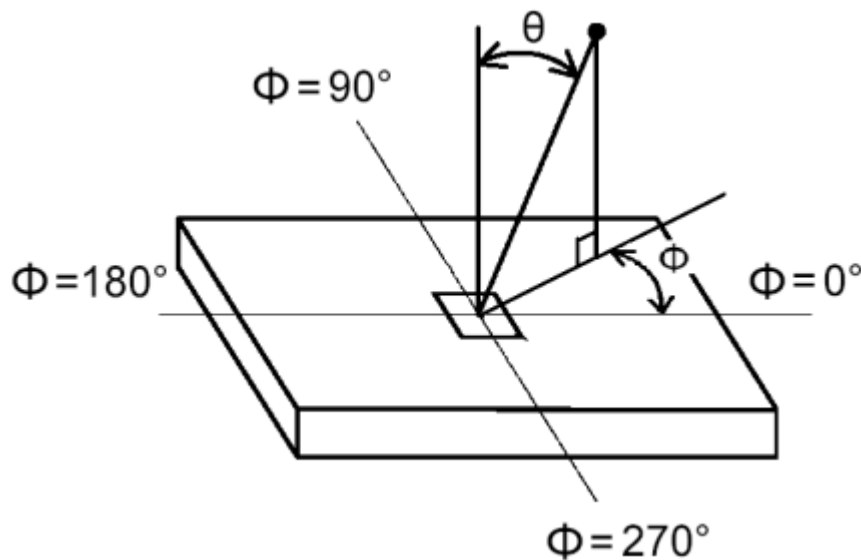

FIG. 2 Luminance



5. Viewing angle is the angle at which the contrast ratio is greater than 10. The angles are determined for the horizontal or x axis and the vertical or y axis with respect to the z axis which is normal to the LCD surface. For more information see FIG3.

FIG.3 Viewing Angle



## 5. Mechanical Characteristics

The contents provide general mechanical characteristics for the model T370HW05 V0. In addition the figures in the next page are detailed mechanical drawing of the LCD.

Item		Dimension	Unit	Note
Outline Dimension	Horizontal	856.4	mm	
	Vertical	501	mm	
	Depth (Dmin)	10.8	mm	to rear
Weight	6		Kg	

Front View

“Details of dimension depend on MIF (Mechanical Interface).”

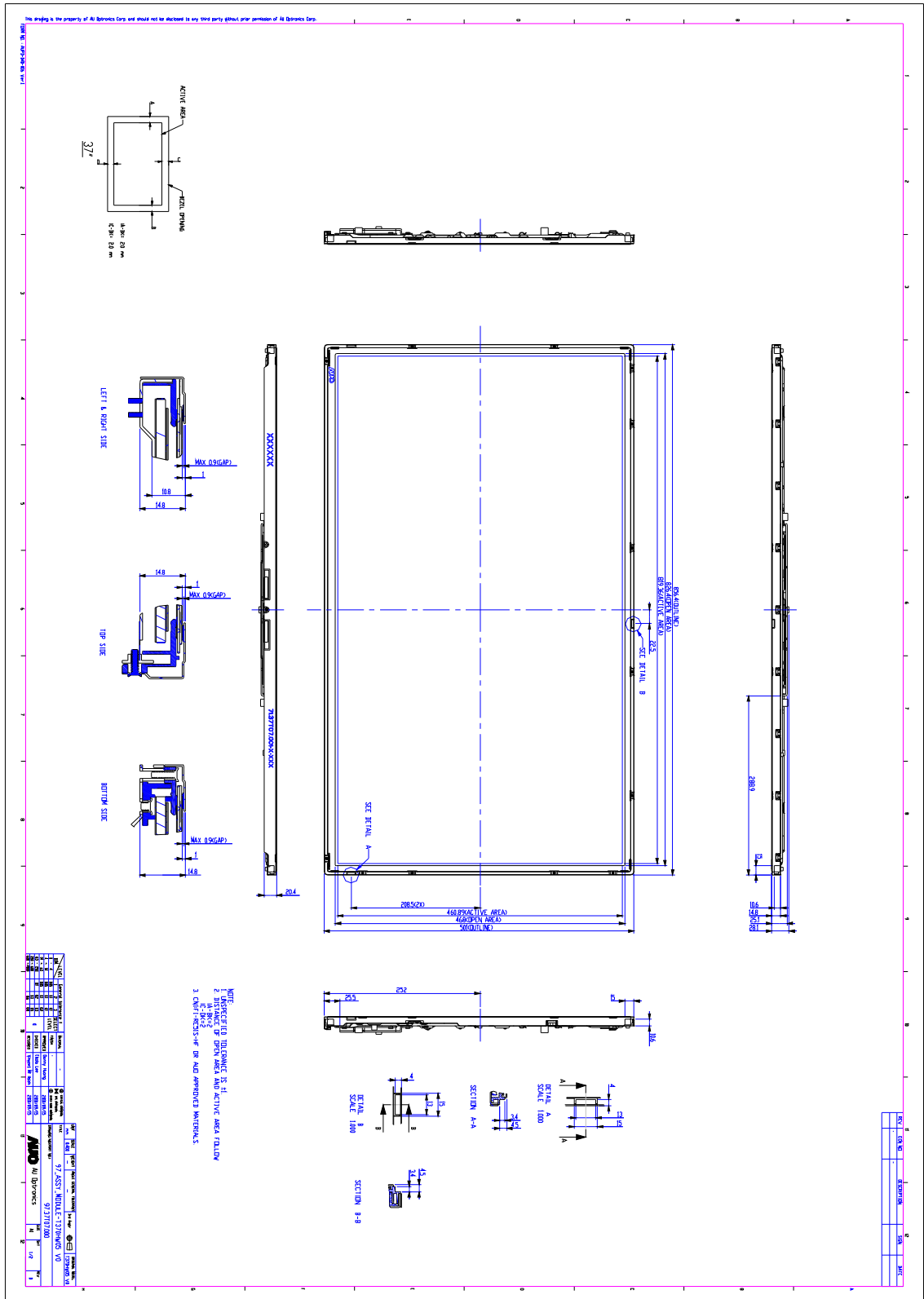

**Back View**

“Details of dimension depend on MIF (Mechanical Interface).”

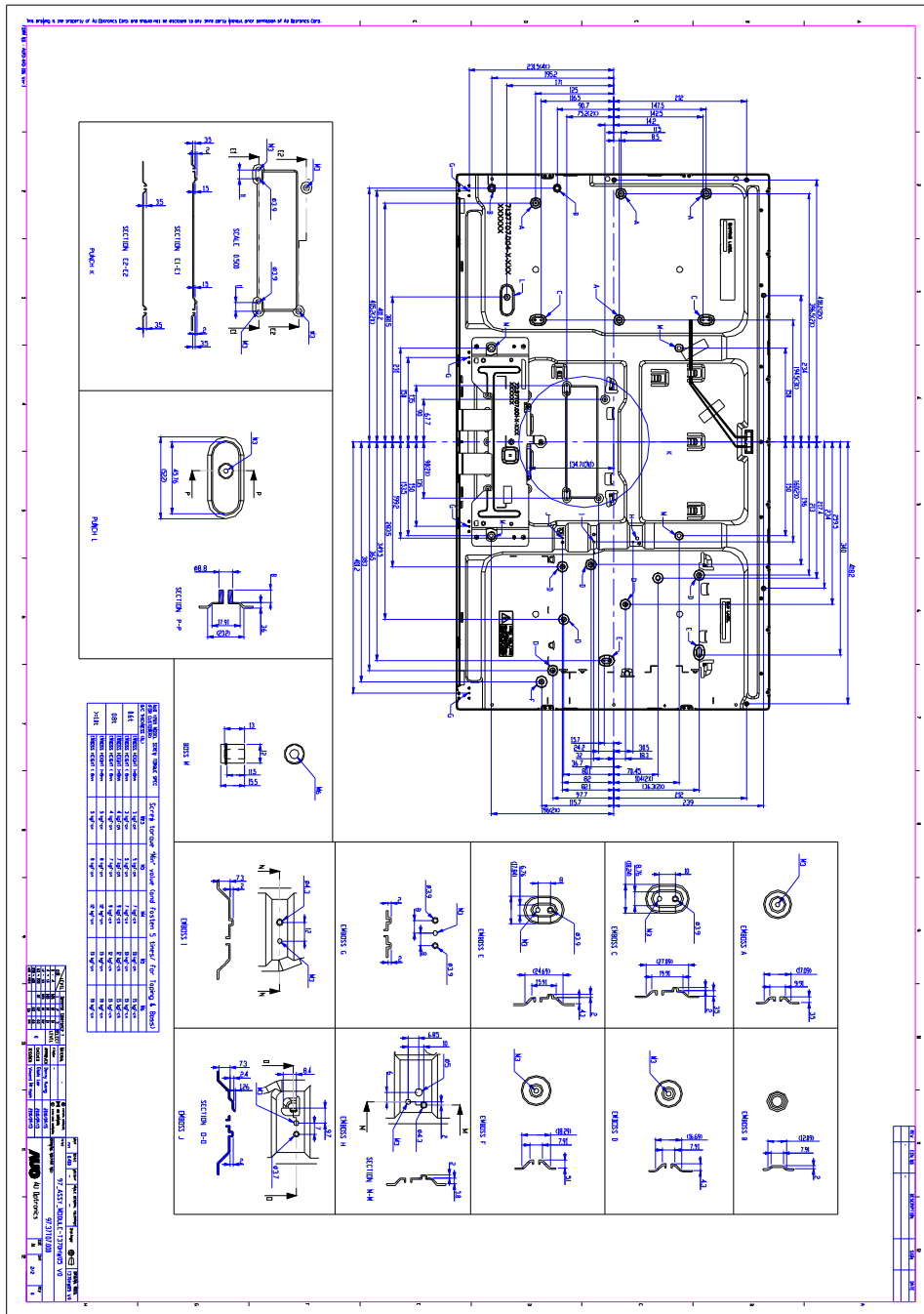



## 6. Reliability Test Items

	Test Item	Q'ty	Condition
1	High temperature storage test	3	60°C, 300hrs
2	Low temperature storage test	3	-20°C, 300hrs
3	High temperature operation test	3	50°C, 300hrs
4	Low temperature operation test	3	-5°C, 300hrs
5	Vibration test (non-operation)	3	Wave form: random Vibration level : 1.0G RMS Bandwidth : 10-300Hz Duration : X,Y,Z 10min per axes X,Y,Z: Horizontal, face up
6	Shock test (non-operation)	3	Shock level 50G ,11ms ±X,Y,Z axis Waveform: half sine wave Direction: One time each direction
7	Vibration test (With carton)	5	Random wave (1.05Grms 10~200Hz) Duration : X,Y,Z 10min per axes
8	Drop test (With carton)	5	Height: 38.1cm (ASTMD4169-I) 1 corner, 3 edges, 6 surfaces (refer ASTM D 5276)

## 7. International Standard

### 7.1 Safety

- (1) UL 60950-1, UL 60065; Standard for Safety of Information Technology Equipment Including electrical Business Equipment.
- (2) IEC 60950-1 : 2001, IEC 60065:2001 ; Standard for Safety of International Electrotechnical Commission
- (3) EN 60950 : 2001+A11, EN 60065:2002+A1:2006; European Committee for Electrotechnical Standardization (CENELEC), EUROPEAN STANDARD for Safety of Information Technology Equipment Including Electrical Business Equipment.

### 7.2 EMC

- (1) ANSI C63.4 "Methods of Measurement of Radio-Noise Emissions from Low-Voltage Electrical and Electrical Equipment in the Range of 9kHz to 40GHz. "American National standards Institute(ANSI), 1992
- (2) C.I.S.P.R "Limits and Methods of Measurement of Radio Interface Characteristics of Information Technology Equipment." International Special committee on Radio Interference.
- (3) EN 55022 "Limits and Methods of Measurement of Radio Interface Characteristics of Information Technology Equipment." European Committee for Electrotechnical Standardization. (CENELEC), 1998



## 8. Packing

### 8-1 DEFINITION OF LABEL:

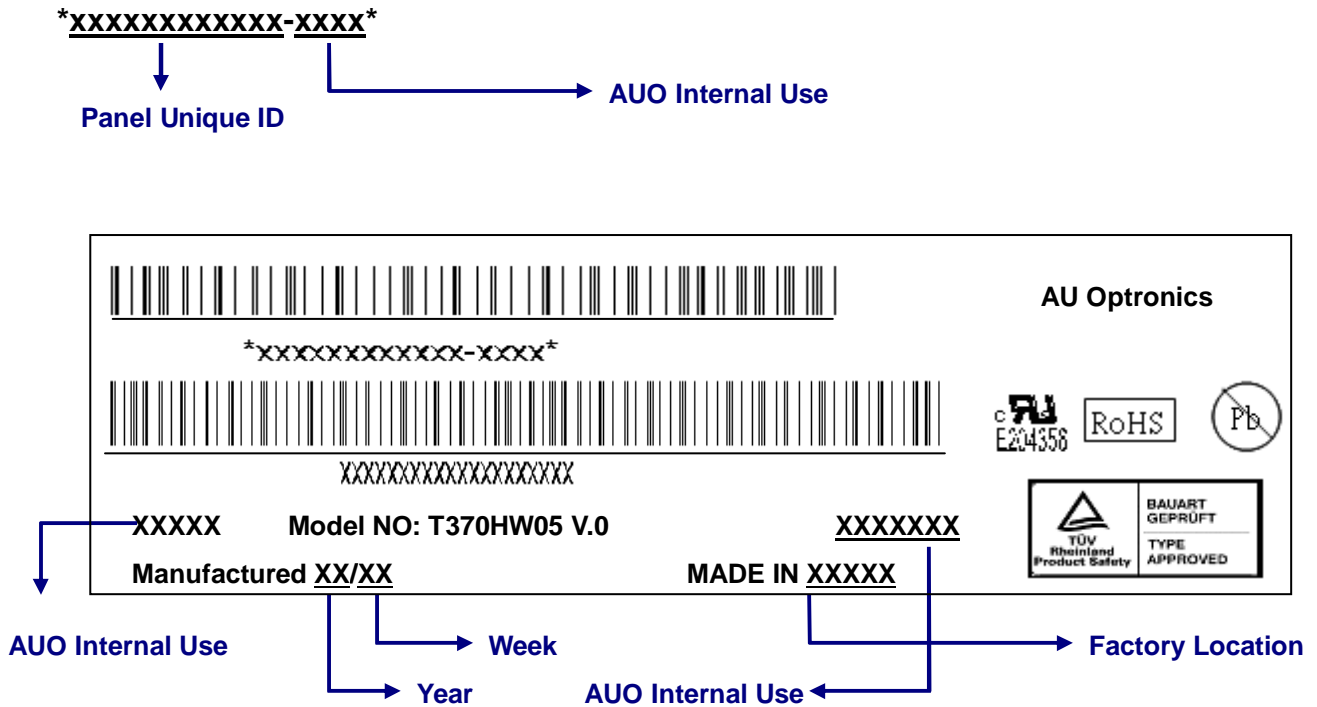
#### A. Panel Label:



#### Green mark description

- (1) For Pb Free Product, AUO will add  for identification.
- (2) For RoHs compatible products, AUO will add  for identification.

Note: The green Mark will be present only when the green documents have been ready by AUO internal green team. (definition of green design follows the AUO green design checklist.)

#### B. Carton Label:

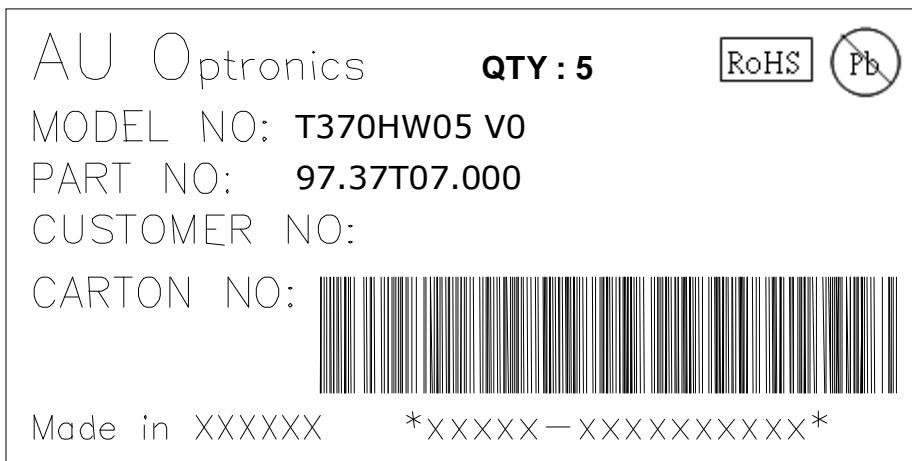

**8-2 PACKING METHODS:**

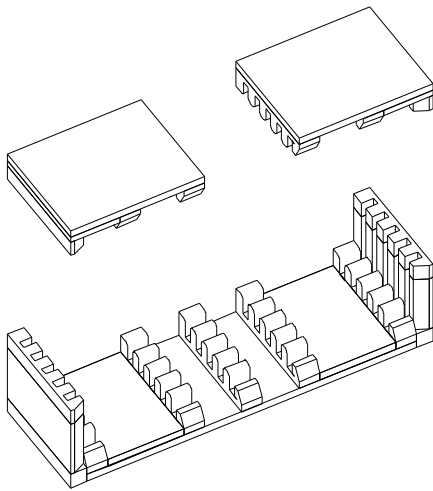
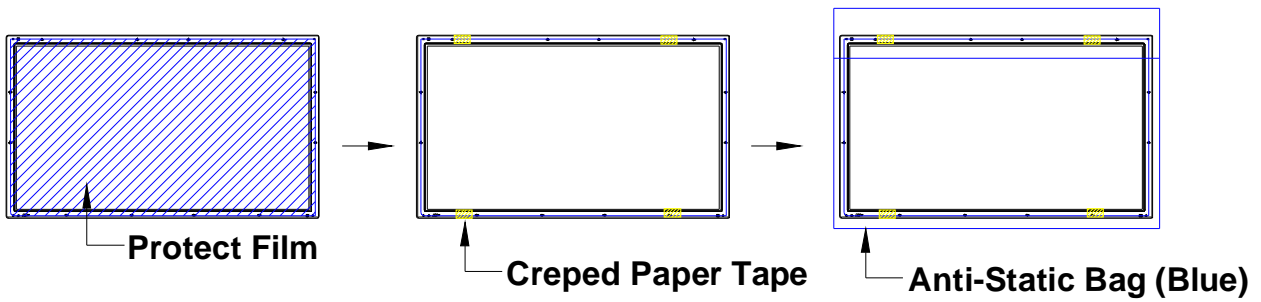

**Cushion Set**

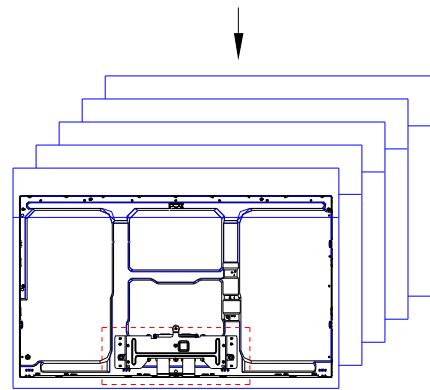

**(5) Pcs Modules**

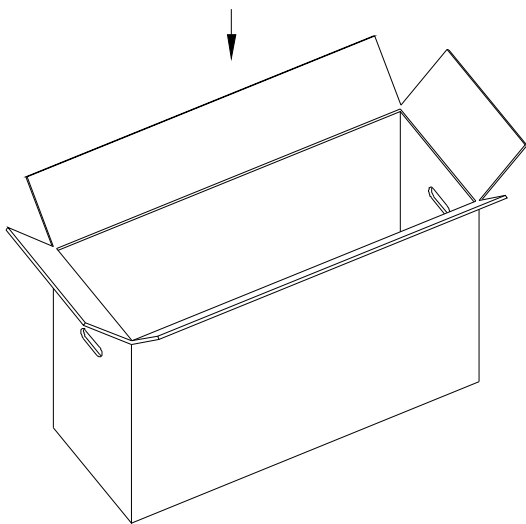

**(5) Pcs / 1 Carton**

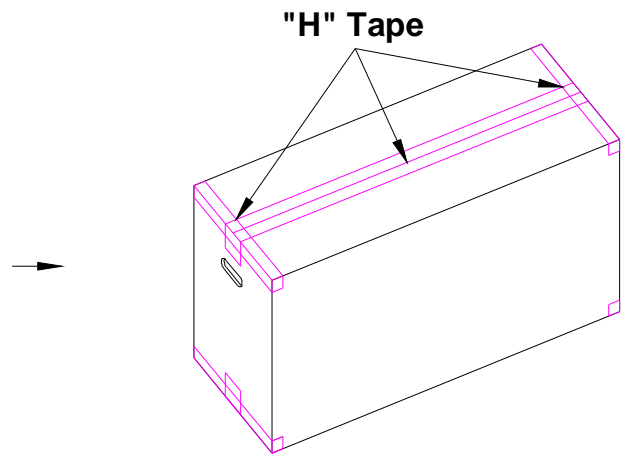

**"H" Tape**

**8-3 Pallet and Shipment Information**

	Item	Specification			Packing Remark
		Qty.	Dimension	Weight (kg)	
1	Packing BOX	5pcs/box	900(L)*280(W)*610(H)	43	
2	Pallet	1	1150(L)*910(W)*132(H)	12	
3	Boxes per Pallet	8 boxes/pallet			
4	Panels per Pallet	40pcs/pallet			

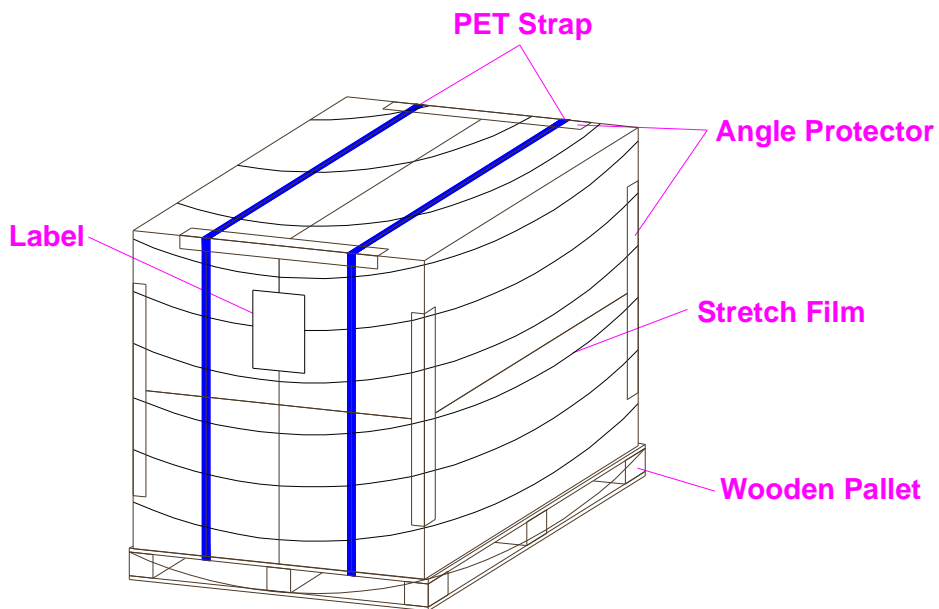

## 9. PRECAUTIONS

Please pay attention to the followings when you use this TFT LCD module.

### 9-1 MOUNTING PRECAUTIONS

- (1) You must mount a module using holes arranged in four corners or four sides.
- (2) You should consider the mounting structure so that uneven force (ex. twisted stress) is not applied to module. And the case on which a module is mounted should have sufficient strength so that external force is not transmitted directly to the module.
- (3) Please attach the surface transparent protective plate to the surface in order to protect the polarizer. Transparent protective plate should have sufficient strength in order to resist external force.
- (4) You should adopt radiation structure to satisfy the temperature specification.
- (5) Acetic acid type and chlorine type materials for the cover case are not desirable because the former generates corrosive gas of attacking the polarizer at high temperature and the latter cause circuit broken by electro-chemical reaction.
- (6) Do not touch, push or rub the exposed polarizer with glass, tweezers or anything harder than HB pencil lead. And please do not rub with dust clothes with chemical treatment. Do not touch the surface of polarizer for bare hand or greasy cloth. (Some cosmetics are detrimental to the polarizer.)
- (7) When the surface becomes dusty, please wipe gently with absorbent cotton or other soft materials like chamois soaks with petroleum benzene. Normal-hexane is recommended for cleaning the adhesives used to attach front/ rear polarizer. Do not use acetone, toluene and alcohol because they cause chemical damage to the polarizer.
- (8) Wipe off saliva or water drops as soon as possible. Their long time contact with polarizer causes deformations and color fading.
- (9) Do not open the case because inside circuits do not have sufficient strength.

### 9-2 OPERATING PRECAUTIONS

- (1) The device listed in the product specification sheets was designed and manufactured for TV application
- (2) The spike noise causes the mis-operation of circuits. It should be lower than following voltage:  
 $V=\pm 200\text{mV}$ (Over and under shoot voltage)
- (3) Response time depends on the temperature. (In lower temperature, it becomes longer..)
- (4) Brightness of CCFL depends on the temperature. (In lower temperature, it becomes lower.) And in lower temperature, response time (required time that brightness is stable after turned on) becomes longer.
- (5) Be careful for condensation at sudden temperature change. Condensation makes damage to polarizer or electrical contacted parts. And after fading condensation, smear or spot will occur.
- (6) When fixed patterns are displayed for a long time, remnant image is likely to occur.
- (7) Module has high frequency circuits. Sufficient suppression to the electromagnetic interference shall

be done by system manufacturers. Grounding and shielding methods may be important to minimize the interface.

### **9-3 ELECTROSTATIC DISCHARGE CONTROL**

Since a module is composed of electronic circuits, it is not strong to electrostatic discharge. Make certain that treatment persons are connected to ground through wristband etc. And don't touch interface pin directly.

### **9-4 PRECAUTIONS FOR STRONG LIGHT EXPOSURE**

Strong light exposure causes degradation of polarizer and color filter.

### **9-5 STORAGE**

When storing modules as spares for a long time, the following precautions are necessary.

- (1) Store them in a dark place. Do not expose the module to sunlight or fluorescent light. Keep the temperature between 5°C and 35°C at normal humidity.
- (2) The polarizer surface should not come in contact with any other object. It is recommended that they be stored in the container in which they were shipped.

### **9-6 HANDLING PRECAUTIONS FOR PROTECTION FILM**

- (1) The protection film is attached to the bezel with a small masking tape. When the protection film is peeled off, static electricity is generated between the film and polarizer. This should be peeled off slowly and carefully by people who are electrically grounded and with well ion-blown equipment or in such a condition, etc.
- (2) When the module with protection film attached is stored for a long time, sometimes there remains a very small amount of glue still on the bezel after the protection film is peeled off.
- (3) You can remove the glue easily. When the glue remains on the bezel or its vestige is recognized, please wipe them off with absorbent cotton waste or other soft material like chamois soaked with normal-hexane.

## Appendix 1

### EDID:

Item	Description	Value																						
Vendor code	Vendor code 0: - 1: AUO	1																						
Panel Inch	Panel Inch, setting function: 24 inch = 24 / 26 inch = 26 32 inch = 32 / 37 inch = 37 40 inch = 40 / 42 inch = 42 46 inch = 46 / 52 inch = 52	37																						
H. Resolution	Panel Horizontal resolution information. 16 bit : 0x02 = MS Byte, 0x03 = LS Byte (1) Horizontal resolution = 3840 (2) Horizontal resolution = 1920 (3) Horizontal resolution = 1366	1920																						
V. Resolution	Panel Vertical resolution information. 16 bit : 0x04 = MS Byte, 0x05 = LS Byte (1) Vertical resolution = 2160 (2) Vertical resolution = 1080 (3) Vertical resolution = 768	1080																						
V. Frequency	Panel Vertical frequency information 0: 50Hz / 60Hz 1: 100Hz / 120Hz 2: 200Hz / 240Hz	0																						
Data format	Panel LVDS Data format information. 0: 6 bit / 1: 8 bit 2: 10 bit / 3: 12 bit 4: 14 bit / 5: 16 bit	2																						
Part number	Panel maker's version information. <table border="1" data-bbox="694 1753 1252 1977"> <tr> <td>0</td><td>1</td><td>2</td><td>3</td><td>4</td><td>5</td><td>6</td><td>7</td><td>8</td><td>9</td><td>10</td> </tr> <tr> <td>T</td><td>3</td><td>7</td><td>0</td><td>H</td><td>W</td><td>0</td><td>5</td><td></td><td>V</td><td>0</td> </tr> </table>	0	1	2	3	4	5	6	7	8	9	10	T	3	7	0	H	W	0	5		V	0	Capitalization
0	1	2	3	4	5	6	7	8	9	10														
T	3	7	0	H	W	0	5		V	0														



## Appendix 2

EMI specification

Model name: T370HW05 V0

Item	Min	Typ	Max	Unit
EMI level (Note)	---	---	-6	dB( $\mu$ V/m)
SSCG	---	300	---	ps

### Note:

甲、Criteria: CISPR22

乙、Signal generator: PSG400 (Sony EMCS)

丙、EMI site: Sony EMCS Ichinomiya Tec. or using correlation value

丁、Find result should be checked by connecting with TV-set