

Document Version: 1.0

Date:2006/12/1

Product Functional Specification

37" Color TFT-LCD Module
Model Name: T370XW02 V2
(QDI Model: QD37WL0102)

() Preliminary Specification
(*) Final Specification

This specification sheet is for model name change, since AUO merged QDI from 2006/10/1

This Specification Sheet keep the original QDI Model name and Spec.

New Model name and old model name comparison table as following:

	AUO	QDI
Model Name	T370XW02 V2	QD37WL0102
Change Item	1. Carton Printing format 2. Product Serial label format	



Revision History			
REV.	Date	ECN NO.	Change Content
1	12/1		Change AUO product name

TABLE OF CONTENTS

- 1. Application**
- 2. Overview**
- 3. General Specifications**
- 4. Absolute Maximum Ratings**
- 5. Electrical Specification**
 - 5-1. TFT-LCD Module Driving**
 - 5-2. TFT-LCD Pin Assignment**
 - 5-3. Backlight Driving**
 - 5-4. Backlight Inverter Connection**
 - 5-5. Signal Timing**
 - 5-6. Reference of Signal data and color**
- 6. Optical Specification**
- 7. Mechanical Specification**
- 8. Reliability Test**
- 9. Others**

1. Application

This specification applies to a color TFT-LCD module QD37WL01

2. Overview

This module is a color active matrix LCD module incorporating amorphous silicon TFT (Thin Film Transistor). It is composed of a color TFT-LCD panel; driver ICs, control circuit and power supply circuit and a backlight unit. Graphics and texts can be displayed on a 1366x3x768 dots, Wide XGA mode, with 16,777,216 colors by using 8-bit 1 channel LVDS (Low Voltage Differential Signaling) to interface and +12V DC supply voltage for TFT-LCD panel driving.

The TFT-LCD panel used for this module has wide view angles and fast response time. Display mode is normally black. Each pixel is divided into Red, Green and Blue sub-pixels, which are arranged in vertical strips. A low-reflection surface treatment and high-color-saturation type color filter are also used for this panel. Therefore, this module is suitable for the multimedia use. Especially TV can be obtained by using this module.

[Features]

- 1) High contrast image. (1200:1)
- 2) High brilliant image. (500 nits)
- 3) Wide viewing angle. (88/88/88/88)
- 4) Fast response time. (25ms)
- 5) High color saturation. (NTSC 72%)
- 6) WXGA resolution. (1366x768)
- 7) LVDS interface. (8-bit 1 channel)

3. General Specification

Parameter	Specifications	Unit
Display size	37.02" Diagonal	inch
Active area	819.6X460.8	mm
Pixel format	1366 (H)×768 (V) ; (1 pixel = R+G+B dots)	Pixel
Pixel size	0.6 (H) × 0.6 (V)	mm
Pixel configuration	R, G, B vertical stripe	
Color depth	16.7M colors	
Luminance (Center point typ.)	500	Cd/m ²
Contrast Ratio	1200:1	
View angle	Typ. 88/88/88/88	
Display mode	Normally Black	
Unit outline dimensions (typ.)*1	877X516.8X54(inverter cover)	mm
Weight (Max.)	1000	g
Surface treatment	AG (13%), 3H	
Lamp Quantity	Direct 18 Lamps	pcs

*1.Note : excluding backlight cables.

4. Absolute Maximum Ratings

LCD module

Parameter	Symbol	Condition	Ratings	Unit	Remark
Panel Input Voltage	V_{CC}	$T_a=25^{\circ}\text{C}$	-0.3 ~ +14.0	V_{DC}	
Storage temperature	Tstg	—	-20 ~ +60	$^{\circ}\text{C}$	【Note1】
Operating temperature (Ambient)	Topa	—	0 ~ +50	$^{\circ}\text{C}$	

Note 1. Humidity : 90%RH Max. at $T_a \leq 40^{\circ}\text{C}$. Maximum wet-bulb temperature at 39°C or less at $T_a > 40^{\circ}\text{C}$.

No condensation.

5. Electrical Specifications

5-1. TFT-LCD Module Driving

Parameter	Symbol	Min.	Typ.	Max.	Unit	Remark	
V_{CC} Supply voltage	V_{CC}	+11.4	+12.0	+12.6	V	Note 2.	
	Current dissipation	I_{CC}	---	550	850	m A	Note 3.
	Rush current	I_{CCS}	---	---	3.0	A	
	Permissive Input Ripple Voltage	V_{RP}	---	---	120	mV	
Differential input Threshold voltage	High	V_{TH}	---	---	+100	mV	$V_{CM}=+1.2\text{V}$
	Low	V_{TL}	-100	---	---	mV	Note 1.
Input current (High)	I_{OH}	---	---	+/-10	μA	$V_I=2.4\text{V}$ $V_{CC}=3.6\text{V}$	
Input current (Low)	I_{OL}	---	---	+/-10	μA	$V_I=0\text{V}$ $V_{CC}=3.6\text{V}$	
Terminal resistor	R_T	---	100	---	Ω	Differential input	

Note 1. V_{CM} : Common mode voltage of LVDS driver.

Note 2. On-off conditions for supply voltage

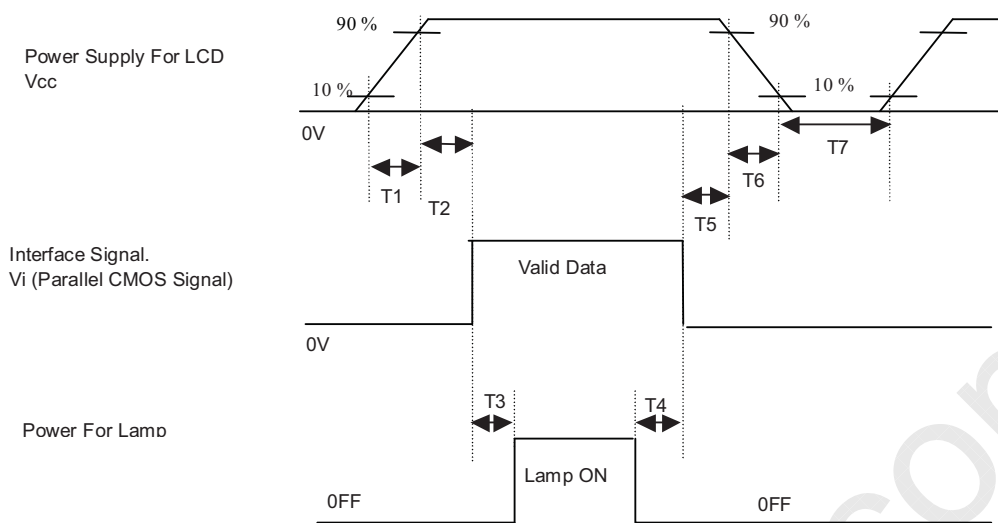

$470\mu s \leq t1 \leq 10\text{ ms}$; $0 < t2 \leq 50\text{ ms}$; $200\text{ ms} \leq t3$; $200\text{ ms} \leq t4$; $0 < t5 \leq 50\text{ ms}$; $0 < t6 \leq 10\text{ ms}$; $400\text{ ms} < t7$

Note 3. Typical current condition: 2-line vertical stripe pattern (0,255GS). V_{CC}=+12V

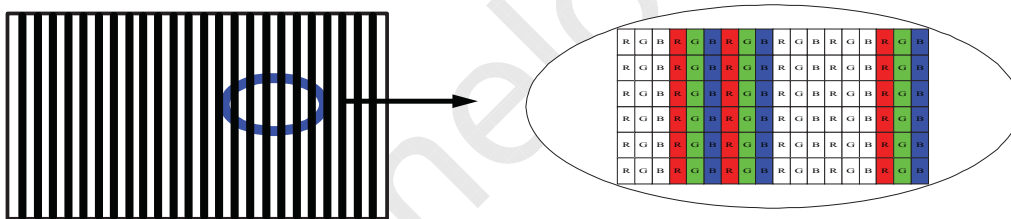

Max current condition: 1x1 dot Checker Board Pattern (0, 255GS). V_{CC}=+12V

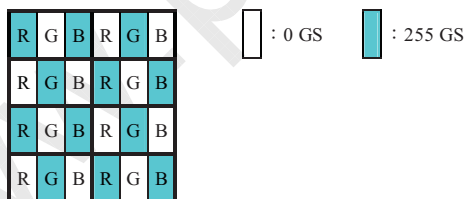

5-2. TFT-LCD Pin Assignment

Mating connector: FI-X30SSL-HF (Manufactured by JAE) or Equivalent

Pin No.	Symbol	Function	Remark
1	VDD	+12V Input	
2	VDD	+12V Input	
3	VDD	+12V Input	
4	VDD	+12V Input	
5	GND	Power Ground	
6	GND	Power Ground	
7	GND	1 Power Ground	
8	GND	Power Ground	
9	LVDS Option	LVDS data mapping	Low/Open for Normal (NS), High for JEIDA
10	Reserved	N.C.	
11	GND	Ground	
12	RXIN0-	LVDS data input	
13	RXIN0+	LVDS data input	
14	GND	Ground	
15	RXIN1-	LVDS data input	
16	RXIN1+	LVDS data input	
17	GND	Ground	
18	RXIN2-	LVDS data input	
19	RXIN2+	LVDS data input	
20	GND	Ground	
21	RXCLKIN-	LVDS data input	
22	RXCLKIN+	LVDS data input	
23	GND	Ground	
24	RXIN3-	LVDS data input	
25	RXIN3+	LVDS data input	
26	GND	Ground	
27	Reserved	N.C.	
28	NTSC_PAL_Selection	OD table selection	Low/Open for PAL High for NTSC
29	GND	Ground	
30	GND	Ground	

Note 1. All GND(ground) pins should be connected together and to VDD which should also be connected to the LCDs metal frame.

Note 2. Relation between LVDS signals and actual data shows below section (7-1).

Note 3. All VDD (power supply) pins should be connected together.

5-3. Backlight driving

The backlight system is a direct-lighting type with 18 CCFT (Cold Cathode Fluorescent Tube). The characteristics of the lamp are shown in the following table.

Parameter	Symbol	Values			Unit	Notes	
		Min	Typ	Max			
Inverter							
Power Supply Input Voltage	VDDB	22.8	24.0	25.2	Vdc		
Power Supply Input Current	IDDB	5.5	6	6.5	A		
Power Consumption	PB	132	144	156	W		
Input Voltage for Control System Signals	BRTI Signal	VBI	0	1.6(NC)	3.3	V	
	BRTC	Low	VBCL	-0.3	0	0.5	
		High	VCBH	2.5	3.3	3.6	
LAMP							
Lamp current	IL	---	5.3	---	mA	rms	
Lamp voltage	V L	1107	1230	1353	Vrms	25°C	
Lamp power consumption	PL	5.8	6.5	6.9	W	Note 2. IL=5.3mA	
Lamp frequency	F0	---	55	---	kHz	Note 3	
Established starting voltage	Vs	---	---	2080	Vrms	Ta = 25°C	
		---	---	2220	Vrms	Ta = 0°C	
Lamp life time	LL	50000	---	---	hour	Note 5.	

Note 1. Lamp current is measured with current meter for high frequency.

Note 2. Calculated Value for reference (IL × V L)

Note 3. Lamp frequency may produce interference with horizontal synchronous frequency, and this may cause beat on the display. Therefore lamp frequency shall be detached as much as possible from the horizontal synchronous frequency and from the harmonics of horizontal synchronous to avoid interference.

Note 4. The voltage above this value should be applied to the lamp for more than 1 second to start-up. Otherwise the lamp may not be turned on.

Note 5. The life is determined as the time at which luminance of the lamp is 50% compared to that of initial value at the typical lamp current on condition of continuous operating at 25 ± 2°C.

Note 6. The performance of the backlight, for example life time or brightness, is much influenced by the characteristics of the DC-AC inverter for the lamp. When you design or order the inverter, please make sure that a poor lighting caused by the mismatch of the backlight and the inverter (miss-lighting, flicker, etc.) never occur. When you confirm it, the module should be operated in the same condition as it is installed in your instrument.

Note 7. Protection function : if one lamp cannot light on well, the inverter will shut down all lamps.

5-4. Backlight Inverter Connection

5-4-1. Inverter Connector:

Connector	Type	Manufactured
CN1	S14 B-PH-SM3 TB	JST or Equivalent
CN2	SM02(12B)-BHS-1-TB	JST or Equivalent
CN3	S2B-ZR-SM3A-TF	JST or Equivalent

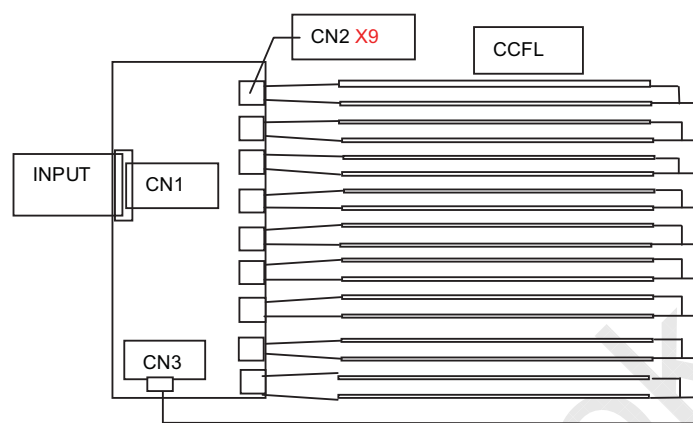

5-4-2. Inverter Connector Pin Assignment :

CN1 S14 B-PH-SM3 TB(JST)or Equivalent

Pin No.	Symbol	Description	Remark
1	VIN	Operating Voltage Supply, +24V DC regulated	24V
2	VIN	Operating Voltage Supply, +24V DC regulated	24V
3	VIN	Operating Voltage Supply, +24V DC regulated	24V
4	VIN	Operating Voltage Supply, +24V DC regulated	24V
5	VIN	Operating Voltage Supply, +24V DC regulated	24V
6	BLGND	Ground and Current Return	GND
7	BLGND	Ground and Current Return	GND
8	BLGND	Ground and Current Return	GND
9	BLGND	Ground and Current Return	GND
10	BLGND	Ground and Current Return	GND
11	ADIM	GND (0V) 80% Lum / Open (1.6V) 100% Lum / High (3.3V) 120% Lum	100%
12	ON/OFF	BL On-Off: Open/High (3.3V) for BL On as default	On
13	PDIM ⁽²⁾	PWM Dimming Control: Open/High (3.3V) for 100% Lum	100%
14	PWM Selection ⁽³⁾	Open/GND: Duty Signal to 13pin, High: Analog Voltage to 13 pin	Analog

Note.1 Luminance ratio is linearly controllable in the range of the following table.

BTRI Voltage (VBI)	Luminance ratio
0V	20% (Minimum)
3.3V	100% (Maximum)

- (1) ADIM is control signal for Inverter's output Power to Back Light Lamp Bulb. Input Signal should be able to control Amplitude of Inverter Output voltage. From 0V to 3.3V, Inverter Output Voltage should be able to vary to control Brightness of Lamp from 80% to 120% Luminescence variation.
- (2) PDIM is PWM control input; i.e. for the given ADIM, this PDIM input should be able to control Width of Voltage Burst of inverter output for Lamp Driving. This input can have two type of input; Ordinary default setting is Duty Signal Input with 3.3V TTL specification. The other setting will be DC level signal using Saw Tooth Wave control for PWM duty control. These two method should be decided by 14th Pin input setting.
- (3) 14 Pin is selection pin for PWM control method; if this pin NC or GND, PDIM input of 13th Pin should be direct Duty Signal Input for PWM control. If this is set to High, 13th Pin should have DC level signal and inverter should have Saw Tooth Wave Generator for PWM.

Rear view of LCM

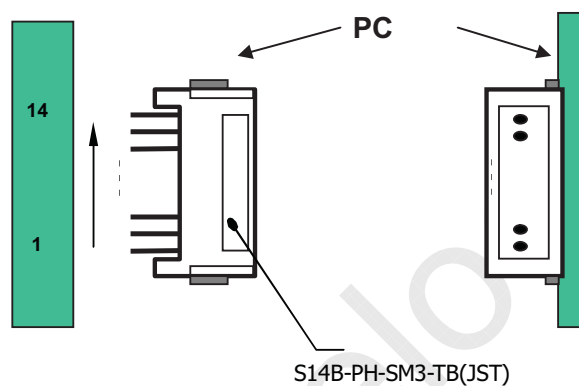

5-5. Signal Timing Spec.

Item	Symbol	Min	Typ	Max	Unit	Notes
DCLK	Frequency	---	80	82	MHz	
	Period	t_{CLK}	12.2	12.5	---	ns
Hsync	Period	t_{HA}	1512	1648	1780	t_{CLK}
	Width-Active	t_{HC}	8	16	---	
	Frequency	fH	44	48.54	52	kHz
Vsync	Frequency	fV	47	60	63	Hz
	Period	t_{VA}	774	810	--	t_{HA}
	Width-Active	t_{VC}	2	6	---	
Data Enable	Horizontal back porch	t_{HD}	8	80	---	t_{CLK}
	Horizontal front porch	t_{HF}	16	186	---	t_{CLK}
	Horizontal active	t_{HE}	1366	1366	1366	t_{CLK}
	Horizontal blanking	t_{HB}	146	282	---	t_{CLK}
	Vertical back porch	t_{VD}	2	20	---	t_{HA}
	Vertical front porch	t_{VF}	2	16	---	t_{HA}
	Vertical active	t_{VE}	768	768	768	t_{HA}
	Vertical blanking	t_{VB}	6	42	---	t_{HA}

Note 1. The performance of electro-optical characteristics may be influenced by variance of the vertical refresh rates.

Note 2. Hsync period shall be a double number of character (8).

Note 3. Signal Timing Waveform as below.

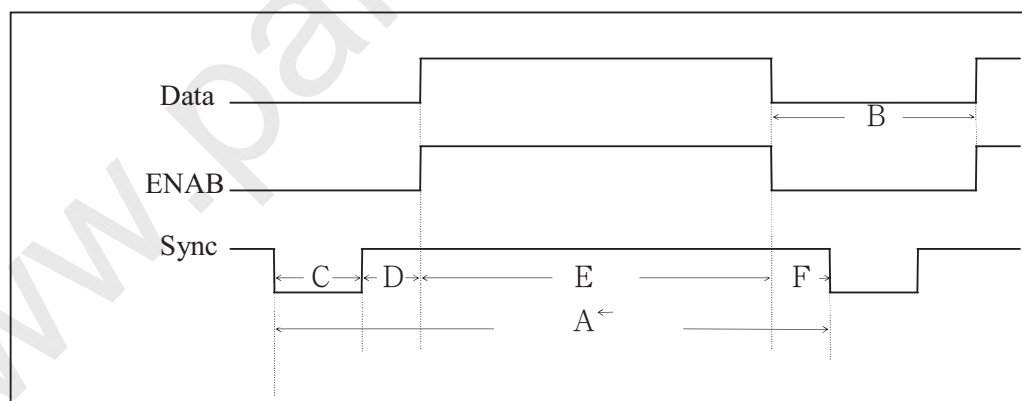



5-6. Reference of Data Signal and Color.

Colors &		Data signal																										
		Gray scale	Gray Scale	R 0	R 1	R 2	R 3	R 4	R 5	R 6	R 7	G 0	G 1	G 2	G 3	G 4	G 5	G 6	G 7	B0	B1	B2	B3	B4	B5	B6	B7	
Basic Color	Black	—	0	0	0	0	0	0	0	0	0	0	0	0	0	0	0	0	0	0	0	0	0	0	0	0	0	
	Blue	—	0	0	0	0	0	0	0	0	0	0	0	0	0	0	0	0	0	0	1	1	1	1	1	1	1	1
	Green	—	0	0	0	0	0	0	0	0	0	1	1	1	1	1	1	1	1	1	0	0	0	0	0	0	0	0
	Cyan	—	0	0	0	0	0	0	0	0	0	1	1	1	1	1	1	1	1	1	1	1	1	1	1	1	1	1
	Red	—	1	1	1	1	1	1	1	1	1	0	0	0	0	0	0	0	0	0	0	0	0	0	0	0	0	0
	Magenta	—	1	1	1	1	1	1	1	1	1	0	0	0	0	0	0	0	0	0	1	1	1	1	1	1	1	1
	Yellow	—	1	1	1	1	1	1	1	1	1	1	1	1	1	1	1	1	1	1	0	0	0	0	0	0	0	0
	White	—	1	1	1	1	1	1	1	1	1	1	1	1	1	1	1	1	1	1	1	1	1	1	1	1	1	1
Gray Scale of Red	Black	GS0	0	0	0	0	0	0	0	0	0	0	0	0	0	0	0	0	0	0	0	0	0	0	0	0	0	0
	↑	GS1	1	0	0	0	0	0	0	0	0	0	0	0	0	0	0	0	0	0	0	0	0	0	0	0	0	0
	Darker	GS2	0	1	0	0	0	0	0	0	0	0	0	0	0	0	0	0	0	0	0	0	0	0	0	0	0	0
	↑	↓					↓									↓								↓				
	↓	↓					↓									↓								↓				
	Brighter	GS253	1	0	1	1	1	1	1	1	1	0	0	0	0	0	0	0	0	0	0	0	0	0	0	0	0	0
	↓	GS254	0	1	1	1	1	1	1	1	1	0	0	0	0	0	0	0	0	0	0	0	0	0	0	0	0	0
	Red	GS255	1	1	1	1	1	1	1	1	1	0	0	0	0	0	0	0	0	0	0	0	0	0	0	0	0	0
Gray Scale of Green	Black	GS0	0	0	0	0	0	0	0	0	0	0	0	0	0	0	0	0	0	0	0	0	0	0	0	0	0	0
	↑	GS1	0	0	0	0	0	0	0	0	0	1	0	0	0	0	0	0	0	0	0	0	0	0	0	0	0	0
	Darker	GS2	0	0	0	0	0	0	0	0	0	0	1	0	0	0	0	0	0	0	0	0	0	0	0	0	0	0
	↑	↓																										
	↓	↓																										
	Brighter	GS253	0	0	0	0	0	0	0	0	0	1	0	1	1	1	1	1	1	1	0	0	0	0	0	0	0	0
	↓	GS254	0	0	0	0	0	0	0	0	0	0	1	1	1	1	1	1	1	1	0	0	0	0	0	0	0	0
	Green	GS255	0	0	0	0	0	0	0	0	0	1	1	1	1	1	1	1	1	1	0	0	0	0	0	0	0	0
Gray Scale of Blue	Black	GS0	0	0	0	0	0	0	0	0	0	0	0	0	0	0	0	0	0	0	0	0	0	0	0	0	0	0
	↑	GS1	0	0	0	0	0	0	0	0	0	0	0	0	0	0	0	0	0	0	1	0	0	0	0	0	0	0
	Darker	GS2	0	0	0	0	0	0	0	0	0	0	0	0	0	0	0	0	0	0	0	1	0	0	0	0	0	0
	↑	↓																										
	↓	↓																										
	Brighter	GS253	0	0	0	0	0	0	0	0	0	0	0	0	0	0	0	0	0	0	1	0	1	1	1	1	1	1
	↓	GS254	0	0	0	0	0	0	0	0	0	0	0	0	0	0	0	0	0	0	0	1	1	1	1	1	1	1
	Blue	GS255	0	0	0	0	0	0	0	0	0	0	0	0	0	0	0	0	0	0	1	1	1	1	1	1	1	1

0 : Low level voltage, 1 : High level voltage

Each basic color can be displayed in 256 gray scales from 8 bit data signals. According to the combination of total 24 bit data signals, the 16,777,216-color display can be achieved on the screen.

©Copyright AU Optronics, Inc.

Sep, 2006 All Rights Reserved.

No Reproduction and Redistribution Allowed

PDF created with FinePrint pdfFactory Pro trial version www.pdffactory.com



6. Optical Specifications

Ta=25°C, V_{CC}=+12V

Parameter		Symbol	Condition	Min.	Typ.	Max.	Unit	Remark	
Viewing angle range	L/R	$\theta 21, \theta 22$	CR>10	80	88	—	Deg.	Note 1,4	
	U	$\theta 11$		80	88	—	Deg.		
	D	$\theta 12$		80	88	—	Deg.		
Contrast ratio		C R n	$\theta =0^\circ$	800	1200	—		Note 2,4	
Response Time (G-G)		τ		—	8	—		Note 3,4,5	
Response time		τ		—	25	—	ms		
Rise time	τr			—	21	—	ms		
Fall time	τd			—	4	—	ms		
Chromaticity of White (CIE 1931)		Wx		0.244	0.274	0.304		Note 4	
		Wy		0.244	0.274	0.304			
Chromaticity of Red (CIE 1931)		Rx		0.608	0.638	0.668		NTSC 72 %	
		Ry		0.309	0.339	0.369			
Chromaticity of Green (CIE 1931)		Gx		0.251	0.281	0.311			
		Gy		0.578	0.608	0.638			
Chromaticity of Blue (CIE 1931)		Bx		0.116	0.146	0.176			
		By		0.039	0.069	0.099			
Luminance of white		Y L		400	500		Cd/m ²		Note 4
White Uniformity		δW (5P)		—	—	1.3			Note 6
White Uniformity		δW (13P)		—	—	1.3		Note 6	
Cross Talk		HDsha%				1		Note 7	
		VDsha%				1			

※ The measurement shall be operated 60 minutes after lighting at rating. (typical condition : IL = TBD mArms)



The optical characteristics shall be measured in a dark room or equivalent state with the method shown in Fig.1 below.

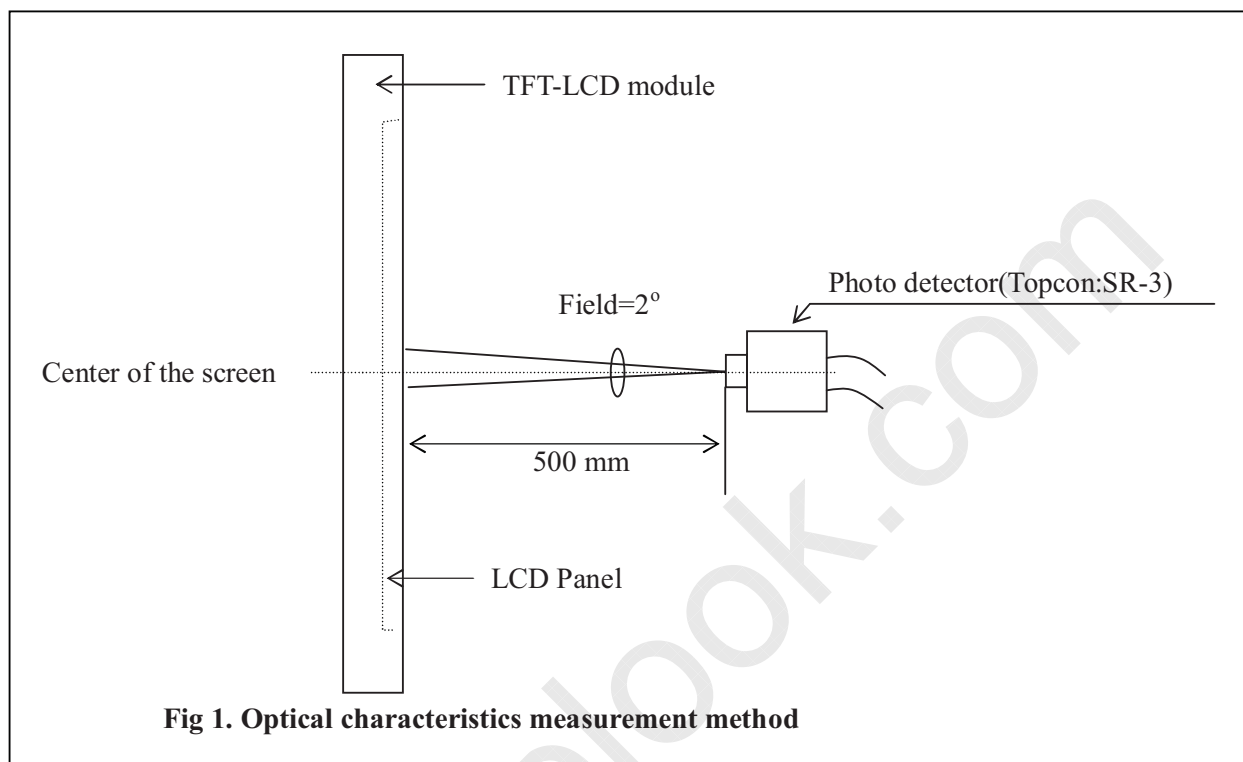

Note 1. Definitions of viewing angle range:

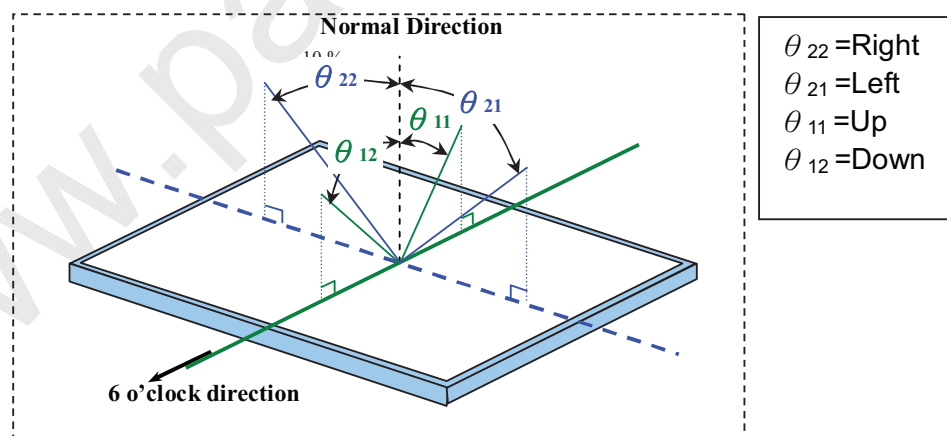

©Copyright AU Optronics, Inc.
 Sep, 2006 All Rights Reserved.
 No Reproduction and Redistribution Allowed

PDF created with FinePrint pdfFactory Pro trial version www.pdffactory.com



Note 2. Definition of contrast ratio:

The contrast ratio is defined as the following.

$$\text{Contrast Ratio (CR)} = \frac{\text{Luminance (brightness) with all pixels white}}{\text{Luminance (brightness) with all pixels black}}$$

Note 3. Definition of response time (black to white):

The response time is defined as the following figure and shall be measured by switching the input signal for "black" and "white".

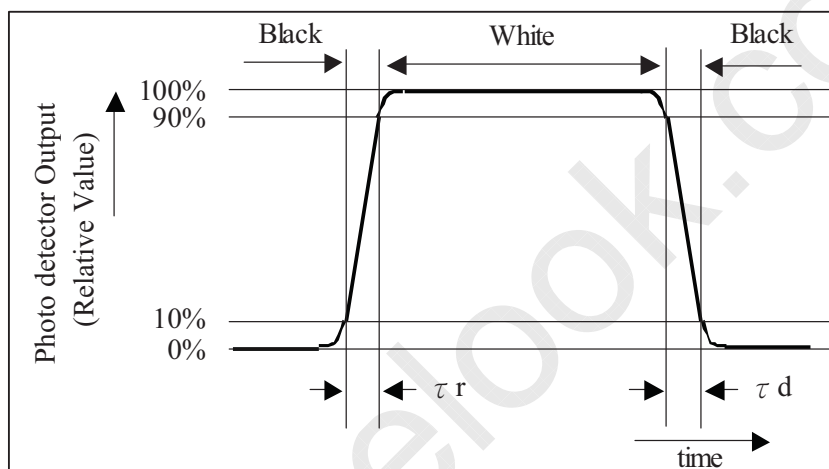

Note 4. This shall be measured at center of the screen.

Note 5. Definition of average gray to gray response time :

The average gray to gray response time is defined as the following figure and shall be measured by switching the input signal for "Original level" and "Target level" at each set levels

Note 6. Definition of white uniformity:

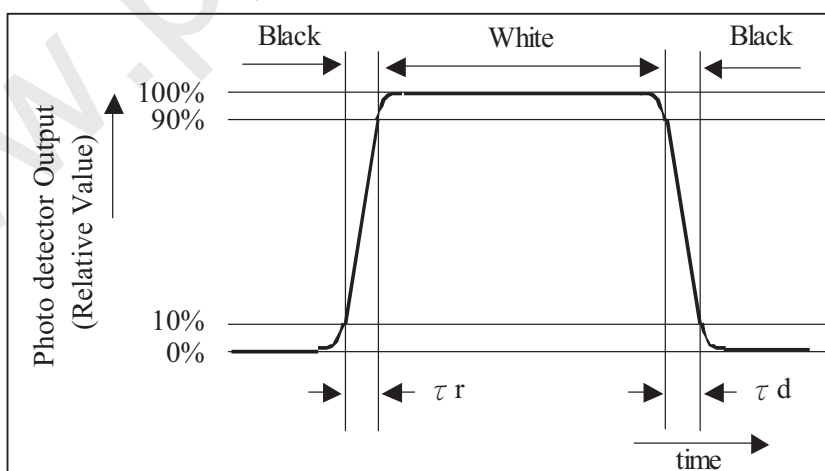

©Copyright AU Optronics, Inc.
Sep, 2006 All Rights Reserved.
No Reproduction and Redistribution Allowed

PDF created with FinePrint pdfFactory Pro trial version www.pdffactory.com



		Rising Time																
		255	240	224	208	192	176	160	144	128	112	96	80	64	48	32	16	0
Falling Time	255	0																
	240		0															
	224			0														
	208				0													
	192					0												
	176						0											
	160							0										
	144								0									
	128									0								
	112										0							
	96											0						
	80												0					
	64													0				
	48														0			
	32															0		
	16																0	
0																	0	

White uniformity is defined as the following the number of measurement points within active area. formula are $\delta_w(5)$ and $\delta_w(13)$

$$\delta_w(5P) = \frac{\text{Maximum Luminance of 5 points}}{\text{Minimum Luminance of 5 points}}$$

$$\delta_w(13P) = \frac{\text{Maximum Luminance of 13 points}}{\text{Minimum Luminance of 13 points}}$$

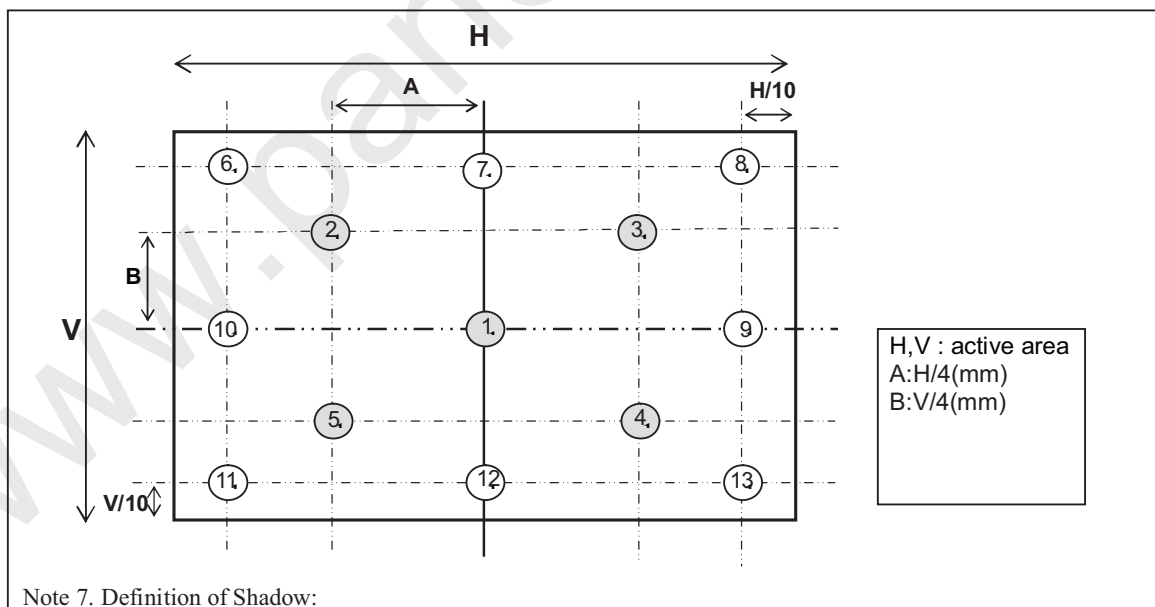

Note 7. Definition of Shadow:

Horizontal Shadow:

Y_{wh} is the brightness of point P1 when module display B pattern

Y_{crs} is the brightness of point P1 when module display A pattern

$$H\text{-Shadow (Dsha\%)} = (| Y_{wh} - Y_{crs} | / Y_{wh}) \times 100$$

©Copyright AU Optronics, Inc.
 Sep, 2006 All Rights Reserved.
 No Reproduction and Redistribution Allowed



Vertical Shadow:

Y_{wh} is the brightness of point P2 when module display B pattern

Y_{crs} is the brightness of point P2 when module display A pattern

$$V\text{-Shadow (Dsha\%)} = (| Y_{wh} - Y_{crs} | / Y_{wh}) \times 100$$

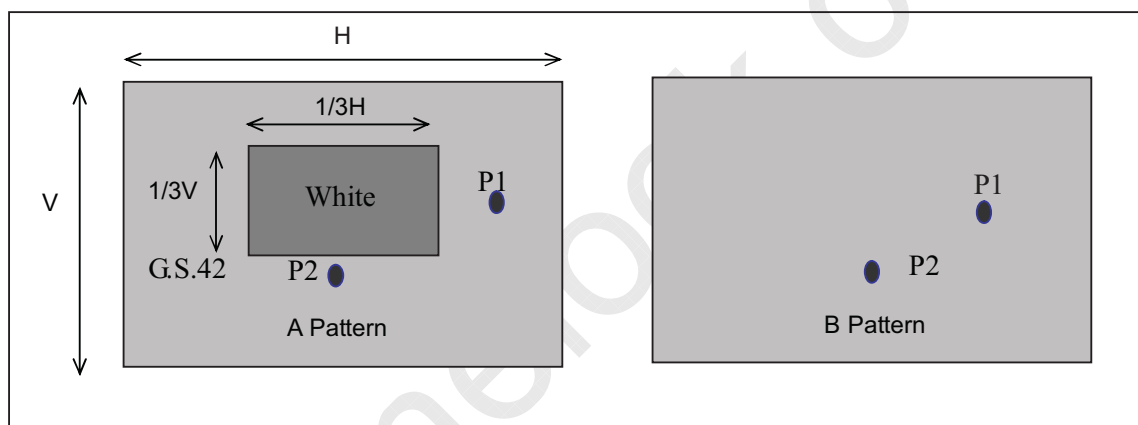

7.Drawing

Front Side(120mm)

©Copyright AU Optronics, Inc.
Sep, 2006 All Rights Reserved.
No Reproduction and Redistribution Allowed

PDF created with FinePrint pdfFactory Pro trial version www.pdffactory.com

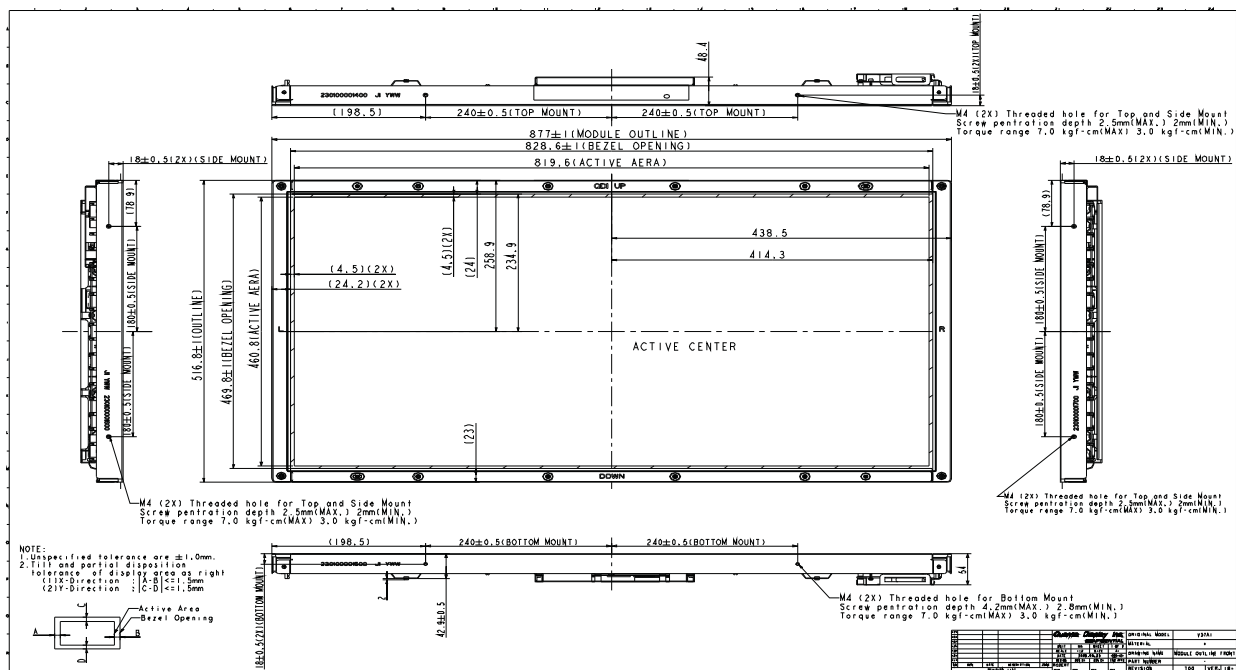

Back Side

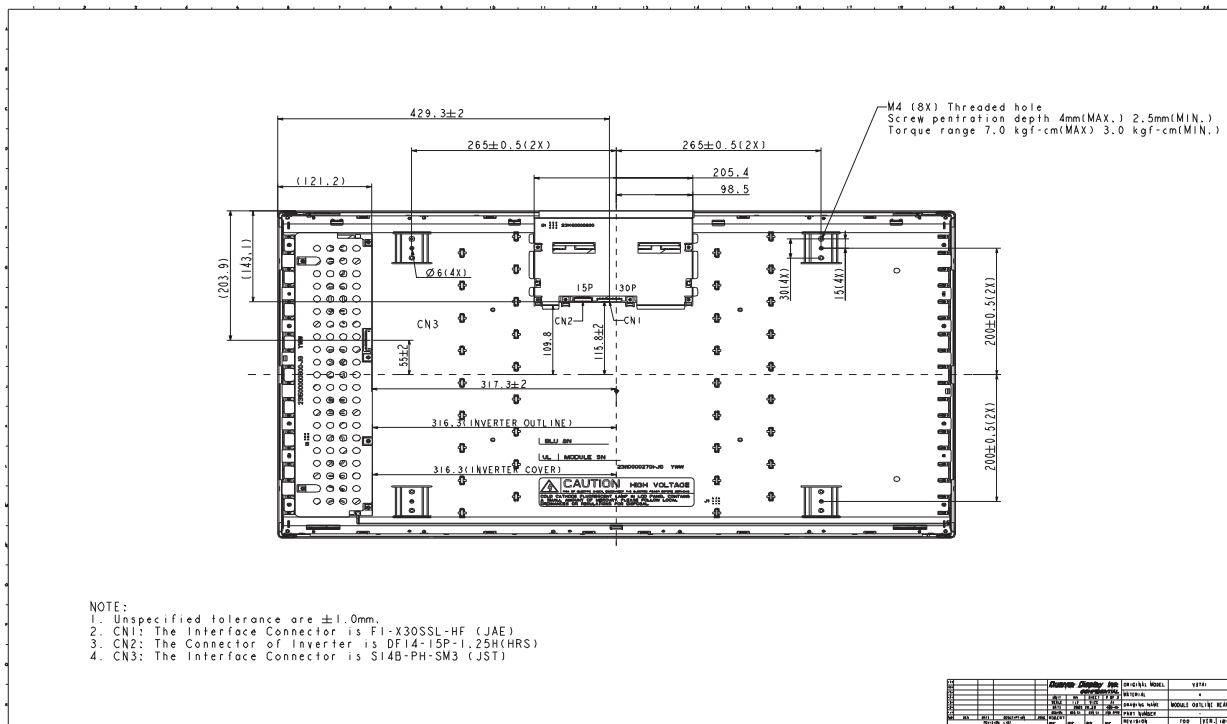

8. Reliability Test

TBD

©Copyright AU Optronics, Inc.
 Sep, 2006 All Rights Reserved.
 No Reproduction and Redistribution Allowed



9. Others

1. LCD Module Label:

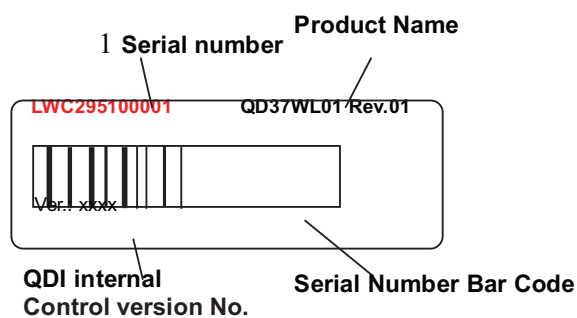

LWC295100001 Digital code 4, 5 is Date code.

Digital 4 (Year) 1: 2001, 2: 2002, 3:2003,....

Digital 5 (Month) 1: Jan, 2: Feb,... , A:Oct, B:Nov., C: Dec.

- Adjusting volume has been set optimally before shipment, so do not change any adjusted value. If adjusted value is changed, the specification may not be satisfied.
- Disassembling the module can cause permanent damage and should be strictly avoided.
- Please be careful since image retention may occur when a fixed pattern is displayed for a long time.
- If any problem occurs in relation to the description of this specification, it shall be resolved through discussion with spirit of cooperation.

©Copyright AU Optronics, Inc.

Sep, 2006 All Rights Reserved.

No Reproduction and Redistribution Allowed

PDF created with FinePrint pdfFactory Pro trial version www.pdffactory.com