

■ **Features**

- I_o 3.0A
- V_{RRM} 200V~800V
- Glass passivated chip
- High surge forward current capability
- Small size
- Halogen Free product

■ **Applications**

- General purpose 1 phase Bridge rectifier applications

■ The UL No. is E255340

Outline Dimensions and Mark
2K Unit: mm

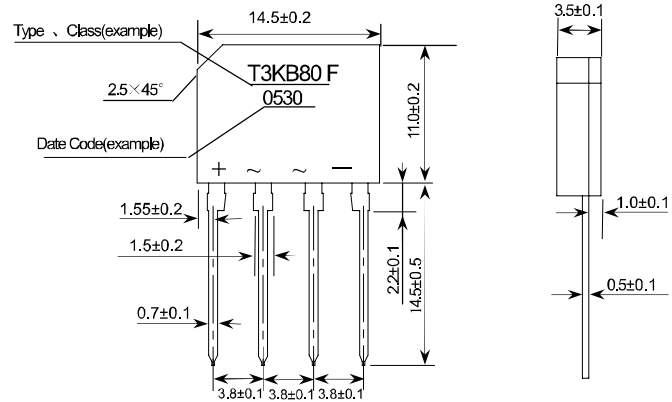

■ **Limiting Values (Absolute Maximum Rating)**

Item	Symbol	Unit	Conditions	T3KB			
				20F	40F	60F	80F
Storage Temperature	T_{stg}	°C		-40 ~ +150			
Junction Temperature	T_j	°C		+150			
Repetitive Peak Reverse Voltage	V_{RRM}	V		200	400	600	800
Average Rectified Output Current	I_o	A	50Hz sine wave, R-load, without heatsink $T_a=25^\circ\text{C}$	2.0			
			50Hz sine wave, R-load, with heatsink $T_c=140^\circ\text{C}$	3.0			
			50Hz sine wave, R-load, without heatsink $T_c=92^\circ\text{C}$	2.0			
Surge(Non-repetitive)Forward Current	I_{FSM}	A	50Hz sine wave, 1 cycle, $T_a=25^\circ\text{C}$	90			
Current Squared Time	I^2t	A ² s	$1\text{ms} \leq t < 8.3\text{ms}$ $T_j=25^\circ\text{C}$, Rating of per diode	34			

■ **Electrical Characteristics** ($T_a=25^\circ\text{C}$ Unless otherwise specified)

Item	Symbol	Unit	Test Condition	Max
Peak Forward Voltage	V_{FM}	V	$I_{FM}=1.5\text{A}$, Pulse measurement, Rating of per diode	1.05
Peak Reverse Current	I_{RRM1}	μA	$V_{RM}=V_{RRM}$, Pulse measurement, Rating of per diode	10
Thermal Resistance	$R_{\theta J-C}$	°C/W	Between junction and case, with heatsink	1.5
	$R_{\theta J-A}$		Between junction and ambient, without heatsink	45
	$R_{\theta J-L}$		Between junction and lead, without heatsink	8

■ Characteristics(Typical)

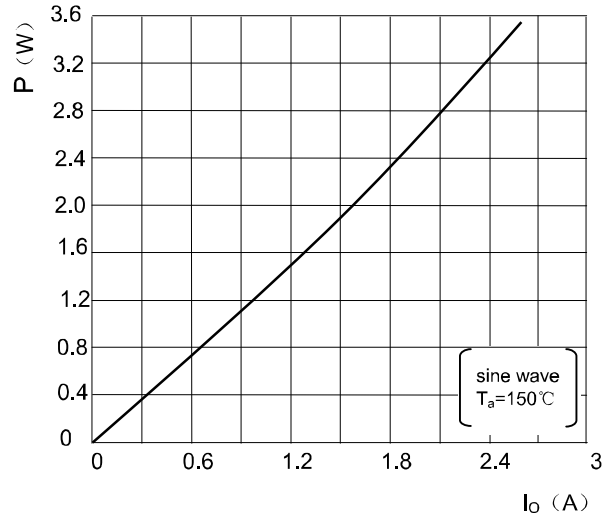
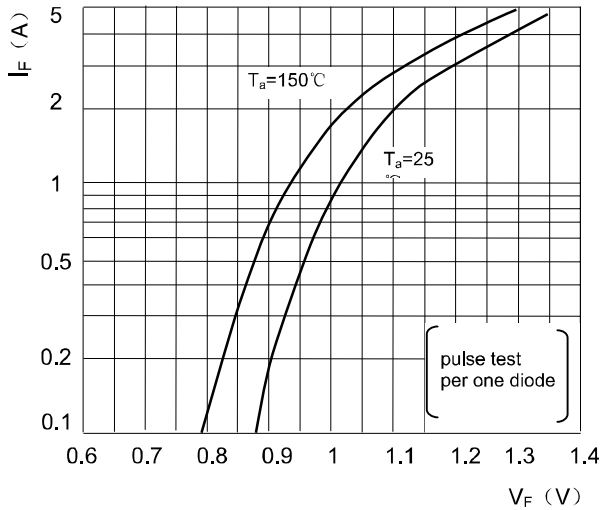

Forward Characteristics

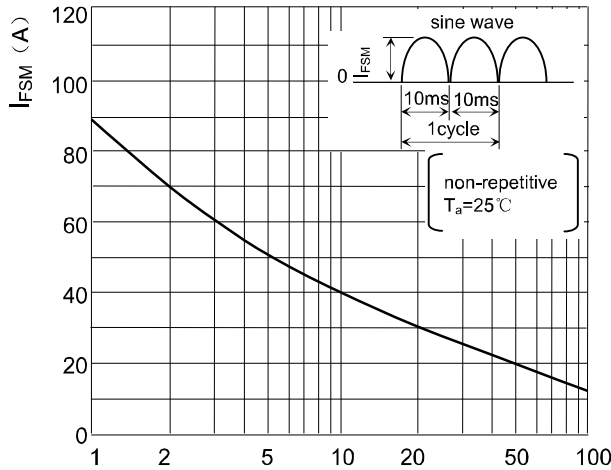

P-IO Curve

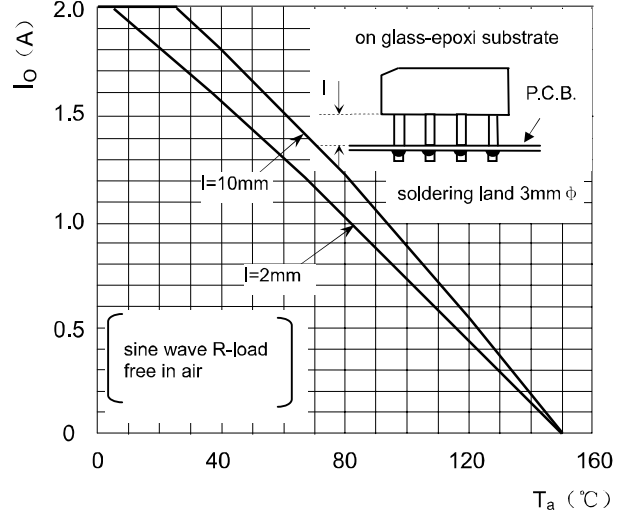

Surge Forward Current Capability

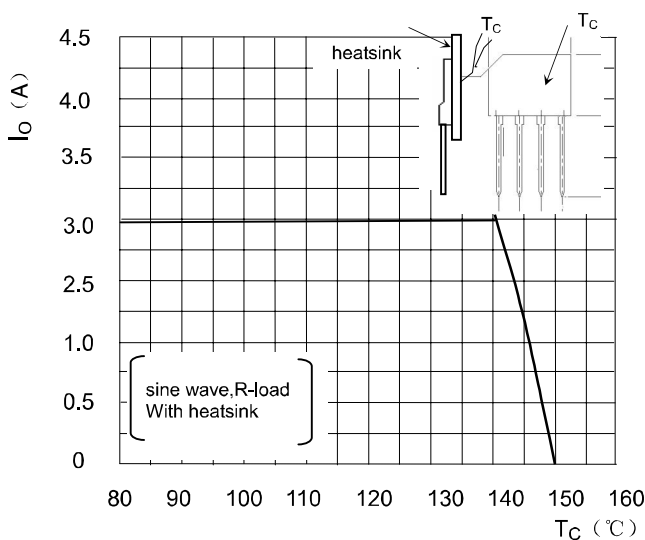

IO-Ta Curve

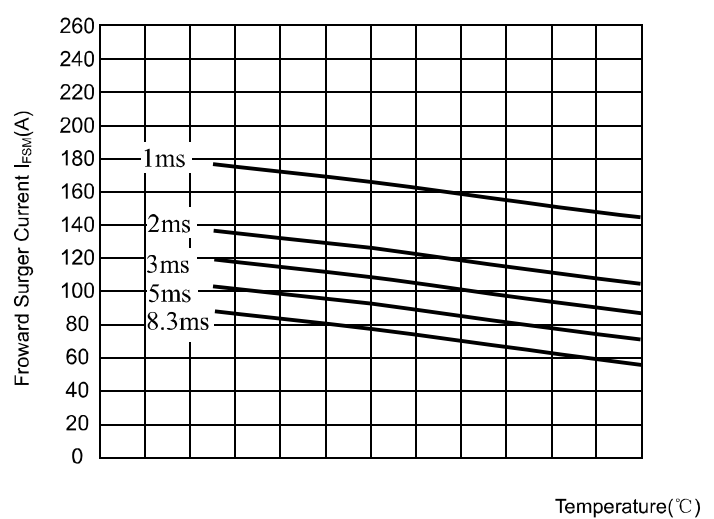

IO-Tc Curve

Maximum Non-Repetitive Peak Forward Surge Current