

# Model Name: T400HW04 V1

**Issue Date: 2011/01/03**

**( ) Preliminary Specifications**  
**(\* ) Final Specifications**

Customer Signature	Date	AUO	Date
Approved By		Approval By PM Director Yen Ting Chiu <i>Yen Ting Chiu</i>	
Note		Reviewed By RD Director Eugene CC Chen <i>Eugene Chen</i> 20/10 12/10	
		Reviewed By Project Leader Stanley Lo <i>Stanley Lo</i>	
		Prepared By PM Joyce Kuo <i>Joyce Kuo</i>	

## Contents

1. General Description .....	4
2. Absolute Maximum Ratings .....	5
3. Electrical Specification .....	6
3.1 Electrical Characteristics .....	6
3.1.1: DC Characteristics .....	6
3.1.2: AC Characteristics .....	7
3.3 Signal Timing Specification .....	14
3.4 Signal Timing Waveforms .....	15
3.5 Color Input Data Reference .....	16
3.6 Power Sequence for LCD .....	17
3.7 Backlight Specification .....	18
3.7.1 Light bar Driven Condition .....	18
3.7.2 Input Pin Assignment .....	19
4. Optical Specification .....	20
5. Mechanical Characteristics .....	23
6. Reliability Test Items .....	26
7. International Standard .....	27
7.1 Safety .....	27
7.2 EMC .....	27
8. Packing .....	28
8-1 DEFINITION OF LABEL: .....	28
8-2 PACKING METHODS: .....	29
8-3 Pallet and Shipment Information .....	29
8-3 Pallet and Shipment Information .....	30
9. PRECAUTIONS .....	31

## Record of Revision

Version	Date	Page	Description
0.0	2010/12/10		First release
0.1	2011/01/03	6	Update DC Characteristics
		11~12	Add pin assignment
		18	Update BLU power consumption
		24~25	Update Front/Back Drawing
0.2	2011/0/21	18	Update the value of forward voltage

## 1. General Description

This specification applies to the 40.0 inch Color TFT-LCD Module T400HW04 V1. This LCD module has a TFT active matrix type liquid crystal panel 1,920x1,080 pixels, and diagonal size of 40.0 inch. This module supports 1,920x1,080 mode. Each pixel is divided into Red, Green and Blue sub-pixels or dots which are arranged in vertical stripes. Gray scale or the brightness of the sub-pixel color is determined with a 10-bit gray scale signal for each dot.

The T400HW04 V1 has been designed to apply the 10-bit 2 channel LVDS interface method. It is intended to support displays where high brightness, wide viewing angle, high color saturation, and high color depth are very important.

### \* General Information

Items	Specification	Unit	Note
Active Screen Size	40.00	inch	
Display Area	885.6(H) x 498.15(V)	mm	
Outline Dimension	921.7(H) x 537.8 (V) x 27.5(D)	mm	D: front bezel to T-con cover
Driver Element	a-Si TFT active matrix		
Bezel Opening	891.7 (H) x 504.8 (V)	mm	
Display Colors	10 bit, 1.07B	Colors	
Number of Pixels	1,920x1,080	Pixel	
Pixel Pitch	0.46125 (H) x 0.46125(W)	mm	
Pixel Arrangement	RGB vertical stripe		
Display Operation Mode	Normally Black		
Surface Treatment	Anti-Glare, 3H		Haze=2%
Rotate Function	Unachievable		Note 1

Note 1: Rotate Function refers to LCD display could be able to rotate.

## 2. Absolute Maximum Ratings

The followings are maximum values which, if exceeded, may cause faulty operation or damage to the unit

Item	Symbol	Min	Max	Unit	Conditions
Logic/LCD Drive Voltage	Vcc	-0.3	14	[Volt]	Note 1
Input Voltage of Signal	Vin	-0.3	4	[Volt]	Note 1
Operating Temperature	TOP	0	+50	[°C]	Note 2
Operating Humidity	HOP	10	90	[%RH]	Note 2
Storage Temperature	TST	-20	+60	[°C]	Note 2
Storage Humidity	HST	10	90	[%RH]	Note 2
Panel Surface Temperature	PST		65	[°C]	Note 3

Note 1: Duration: 50 msec.

Note 2: Maximum Wet-Bulb should be 39°C and No condensation.

The relative humidity must not exceed 90% non-condensing at temperatures of 40°C or less. At temperatures greater than 40°C, the wet bulb temperature must not exceed 39°C.

Note 3: Surface temperature is measured at 50°C Dry condition

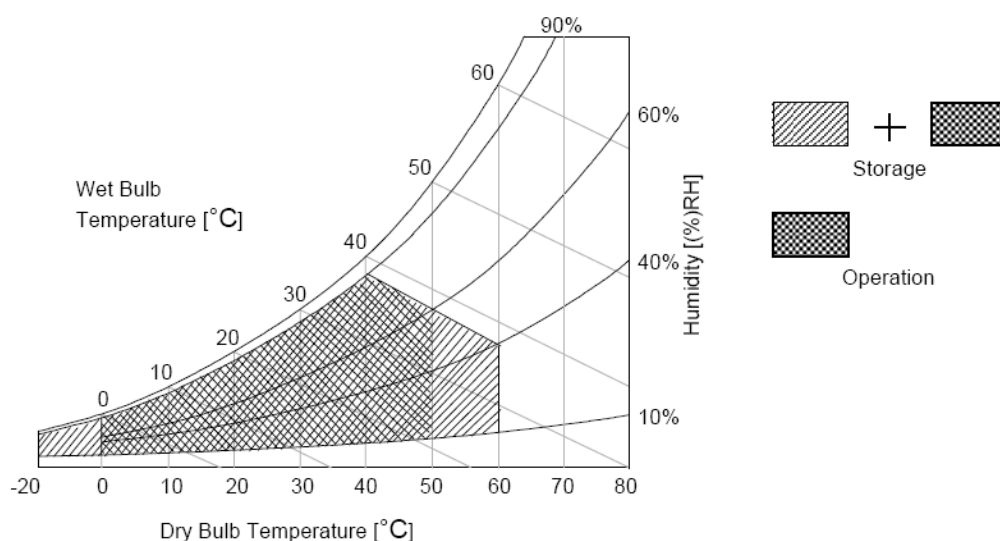

### 3. Electrical Specification

The T400HW04 V1 requires two power inputs. One is employed to power the LCD electronics and to drive the TFT array and liquid crystal. The other is to power Back Light Unit.

#### 3.1 Electrical Characteristics

##### 3.1.1: DC Characteristics

Parameter		Symbol	Value			Unit	Note
			Min.	Typ.	Max		
LCD							
Power Supply Input Voltage		$V_{DD}$	10.8	12	13.2	$V_{DC}$	
Power Supply Input Current		$I_{DD}$	--	0.53	0.9	A	1
Power Consumption		$P_C$	--	6.36	10.8	Watt	1
Inrush Current		$I_{RUSH}$	--	--	4	A	2
LVDS Interface	Input Differential Voltage	$ V_{ID} $	150	200	--	$mV_{DC}$	3
	Differential Input High Threshold Voltage	$V_{TH}$	+100	--	--	$mV_{DC}$	3
	Differential Input Low Threshold Voltage	$V_{TL}$	-300	--	-100	$mV_{DC}$	3
	Input Common Mode Voltage	$V_{ICM}$	1.1	1.25	1.4	$V_{DC}$	3
CMOS Interface	Input High Threshold Voltage	$V_{IH}$ (High)	2.7	--	3.3	$V_{DC}$	4
	Input Low Threshold Voltage	$V_{IL}$ (Low)	0	--	0.6	$V_{DC}$	4
Backlight Power Consumption		$P_{BL}$		69.7	73.18	Watt	
Life time (MTTF)			30000			Hour	8,9

### 3.1.2: AC Characteristics

Parameter		Symbol	Value			Unit	Note
			Min.	Typ.	Max		
LVDS Interface	Input Channel Pair Skew Margin	$t_{\text{SKEW (CP)}}$	-500	--	+500	ps	5
	Receiver Clock : Spread Spectrum Modulation range	Fclk_ss	Fclk -3%	--	Fclk +3%	MHz	6
	Receiver Clock : Spread Spectrum Modulation frequency	Fss	30	--	200	KHz	6
	Receiver Data Input Margin Fclk = 85 MHz Fclk = 65 MHz	tRMG	-0.4 -0.5	-- --	0.4 0.5	ns	7

#### Note:

- $V_{\text{DD}} = 12.0\text{V}$ ,  $F_v = 60\text{Hz}$ ,  $F_{\text{clk}} = 74.23\text{MHz}$ ,  $25^\circ\text{C}$ , Test Pattern : White Pattern
- Measurement condition : Rising time = 400us

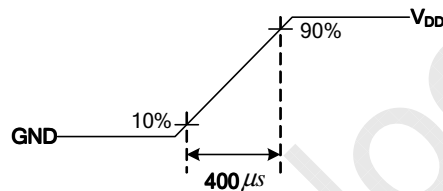

- $V_{\text{ICM}} = 1.25\text{V}$

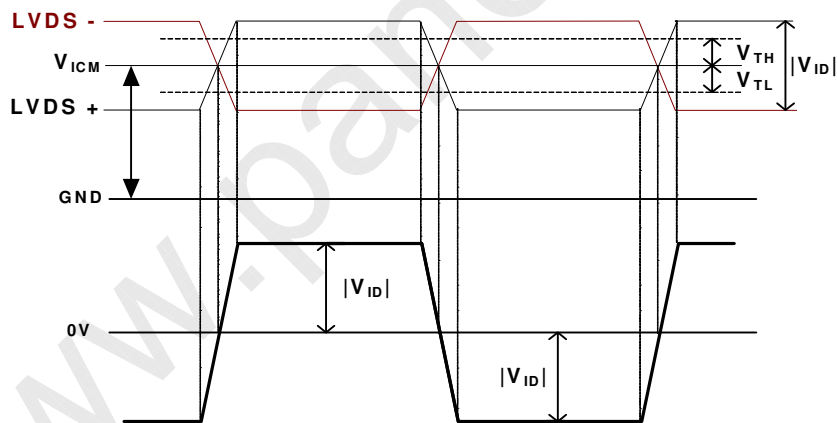

- The measure points of  $V_{\text{IH}}$  and  $V_{\text{IL}}$  are in LCM side after connecting the System Board and LCM.
- Input Channel Pair Skew Margin

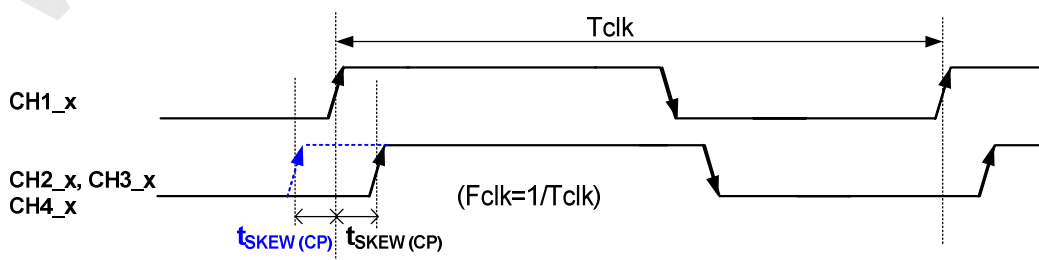

Note: x = 0, 1, 2, 3, 4

6. LVDS Receiver Clock SSCG (Spread spectrum clock generator) is defined as below figures

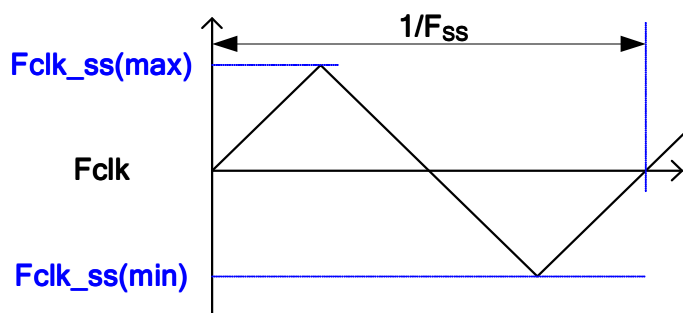

7. Receiver Data Input Margin

Parameter	Symbol	Rating			Unit	Note
		Min	Type	Max		
Input Clock Frequency	Fclk	Fclk (min)	--	Fclk (max)	MHz	$T=1/Fclk$
Input Data Position0	tRIP1	- tRMG	0	tRMG	ns	
Input Data Position1	tRIP0	$T/7- tRMG $	$T/7$	$T/7+ tRMG $	ns	
Input Data Position2	tRIP6	$2T/7- tRMG $	$2T/7$	$2T/7+ tRMG $	ns	
Input Data Position3	tRIP5	$3T/7- tRMG $	$3T/7$	$3T/7+ tRMG $	ns	
Input Data Position4	tRIP4	$4T/7- tRMG $	$4T/7$	$4T/7+ tRMG $	ns	
Input Data Position5	tRIP3	$5T/7- tRMG $	$5T/7$	$5T/7+ tRMG $	ns	
Input Data Position6	tRIP2	$6T/7- tRMG $	$6T/7$	$6T/7+ tRMG $	ns	

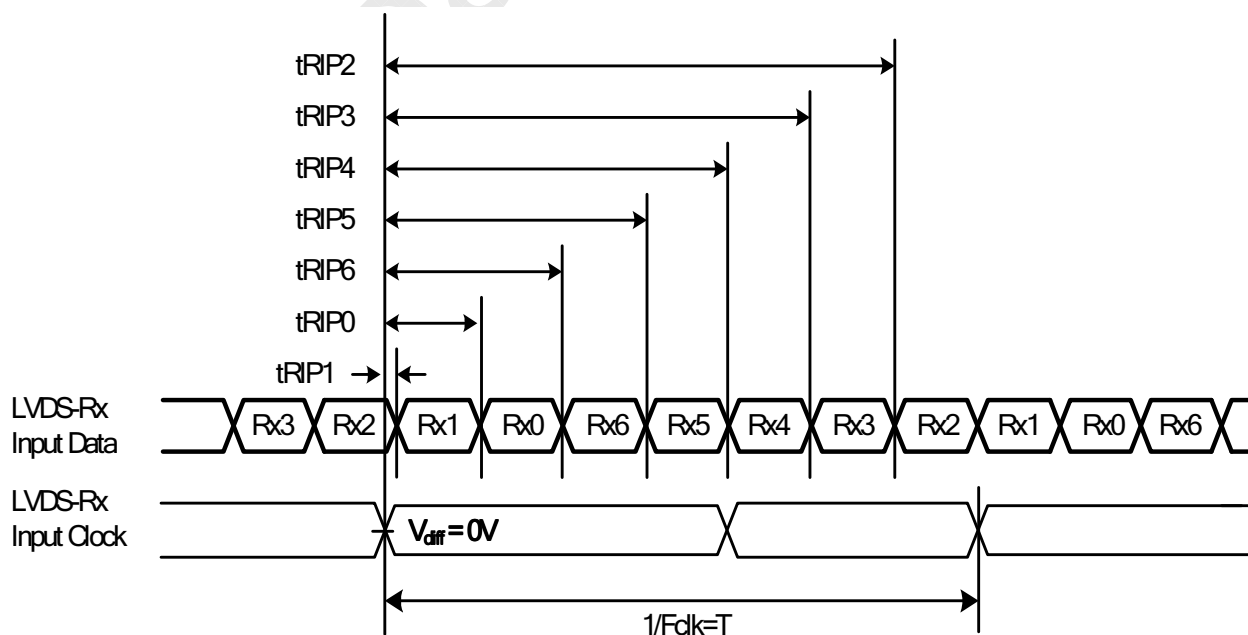



8. The relative humidity must not exceed 80% non-condensing at temperatures of 40°C or less. At temperatures greater than 40°C, the wet bulb temperature must not exceed 39°C. When operate at low temperatures, the brightness of LED will drop and the life time of LED will be reduced.
9. The lifetime (MTTF) is defined as the time which luminance of LED is 50% compared to its original value.  
[Operating condition: Continuous operating at Ta = 25±2°C]

www.panelook.com

### 3.2 Interface Connections

- LCD connector: FI-RE51S-HF (JAE, LVDS connector)
- Mating connector:

PIN	Symbol	Description	PIN	Symbol	Description
1	V <sub>DD</sub>	Power Supply, +12V DC Regulated	26	CH2_0+	LVDS Channel 2, Signal 0+
2	V <sub>DD</sub>	Power Supply, +12V DC Regulated	27	CH2_1-	LVDS Channel 2, Signal 1-
3	V <sub>DD</sub>	Power Supply, +12V DC Regulated	28	CH2_1+	LVDS Channel 2, Signal 1+
4	V <sub>DD</sub>	Power Supply, +12V DC Regulated	29	CH2_2-	LVDS Channel 2, Signal 2-
5	V <sub>DD</sub>	Power Supply, +12V DC Regulated	30	CH2_2+	LVDS Channel 2, Signal 2+
6	N.C.	No connection	31	GND	Ground
7	GND	Ground	32	CH2_CLK-	LVDS Channel 2, Clock -
8	GND	Ground	33	CH2_CLK+	LVDS Channel 2, Clock +
9	GND	Ground	34	GND	Ground
10	CH1_0-	LVDS Channel 1, Signal 0-	35	CH2_3-	LVDS Channel 2, Signal 3-
11	CH1_0+	LVDS Channel 1, Signal 0+	36	CH2_3+	LVDS Channel 2, Signal 3+
12	CH1_1-	LVDS Channel 1, Signal 1-	37	CH2_4-	LVDS Channel 2, Signal 4-
13	CH1_1+	LVDS Channel 1, Signal 1+	38	CH2_4+	LVDS Channel 2, Signal 4+
14	CH1_2-	LVDS Channel 1, Signal 2-	39	GND	Ground
15	CH1_2+	LVDS Channel 1, Signal 2+	40	SCL	EEPROM Serial Clock
16	GND	Ground	41	SDA	EEPROM Serial Data
17	CH1_CLK-	LVDS Channel 1, Clock -	42	N.C.	No connection
18	CH1_CLK+	LVDS Channel 1, Clock +	43	BUS_SW	BUS_SW (SONY internal use only)
19	GND	Ground	44	Panel_SEL	reserve 0402 footprint of resistor to ground (SONY internal use only)
20	CH1_3-	LVDS Channel 1, Signal 3-	45	N.C.	No connection
21	CH1_3+	LVDS Channel 1, Signal 3+	46	SA_MODE	SA_MODE (SONY internal use only)
22	CH1_4-	LVDS Channel 1, Signal 4-	47	FLAGIN	FLAGIN (SONY internal use only)
23	CH1_4+	LVDS Channel 1, Signal 4+	48	N.C.	No connection
24	GND	Ground	49	N.C.	No connection
25	CH2_0-	LVDS Channel 2, Signal 0-	50	TCON_RDY	TCON_RDY (SONY internal use only)
			51	N.C.	AUO Internal Use Only

- LCD connector: SM08B-GHS-TB (JST)

PIN	Symbol	Description
1	V <sub>DD</sub>	Power Supply, +12V DC Regulated
2	V <sub>DD</sub>	Power Supply, +12V DC Regulated
3	GND	Ground
4	GND	Ground
5	GLS_CTRL	GLS_CTRL
6	GLS_CTRL2	GLS_CTRL2
7	EMI_FAIL	EMI_FAIL
8	NC	No connection

- LCD connector: 14FLT-SM2-TB (JST)

PIN	Symbol	Description
1	GPIO2	GPIO2
2	BINT	BINT
3	SPI_WP	SPI_WP
4	SPI_CS	SPI_CS
5	SPI_OUTCTRL	SPI_OUTCTRL
6	GND	Ground
7	SPI_CLK	SPI_CLK
8	GND	Ground
9	SPI_DI	SPI_DI
10	GND	Ground
11	SPI_DO	SPI_DO
12	GND	Ground
13	GND	Ground
14	GND	Ground

- LCD connector: FH31H-56S-0.5SH(08) (HRS)

PIN	Symbol	Description	PIN	Symbol	Description
1	GND	Ground	26	3-PWM5	3-PWM5
2	1-PWM1	1-PWM1	27	3-PWM6	3-PWM6
3	1-PWM2	1-PWM2	28	3-PWM7	3-PWM7
4	1-PWM3	1-PWM3	29	3-PWM8	3-PWM8
5	1-PWM4	1-PWM4	30	GND	Ground
6	1-PWM5	1-PWM5	31	GND	Ground
7	1-PWM6	1-PWM6	32	4-PWM1	4-PWM1
8	1-PWM7	1-PWM7	33	4-PWM2	4-PWM2
9	1-PWM8	1-PWM8	34	4-PWM3	4-PWM3
10	GND	Ground	35	4-PWM4	4-PWM4
11	VLED_MPU	VLED_MPU	36	4-PWM5	4-PWM5
12	2-PWM1	2-PWM1	37	4-PWM6	4-PWM6
13	2-PWM2	2-PWM2	38	4-PWM7	4-PWM7
14	2-PWM3	2-PWM3	39	4-PWM8	4-PWM8
15	2-PWM4	2-PWM4	40	GND	Ground
16	2-PWM5	2-PWM5	41	WP_I2C	WP_I2C
17	2-PWM6	2-PWM6	42	GND_I2C	GND_I2C
18	2-PWM7	2-PWM7	43	VCC_I2C	+3.3V DC Regulated
19	2-PWM8	2-PWM8	44	SDA_I2C	SDA_I2C
20	GND	Ground	45	SCL_I2C	SCL_I2C
21	ADJ_MODE	ADJ_MODE	46	GND	Ground
22	3-PWM1	3-PWM1	47	GND	Ground
23	3-PWM2	3-PWM2	48	12V	Power Supply, +12V DC Regulated
24	3-PWM3	3-PWM3	49	12V	Power Supply, +12V DC Regulated
25	3-PWM4	3-PWM4	50	STDBY	STDBY
			51	POWER_ON	POWER_ON
			52	FAIL	FAIL
			53	REF	REF
			54	BL_TYPE1	BL_TYPE1
			55	BL_TYPE2	BL_TYPE2
			56	GND	Ground

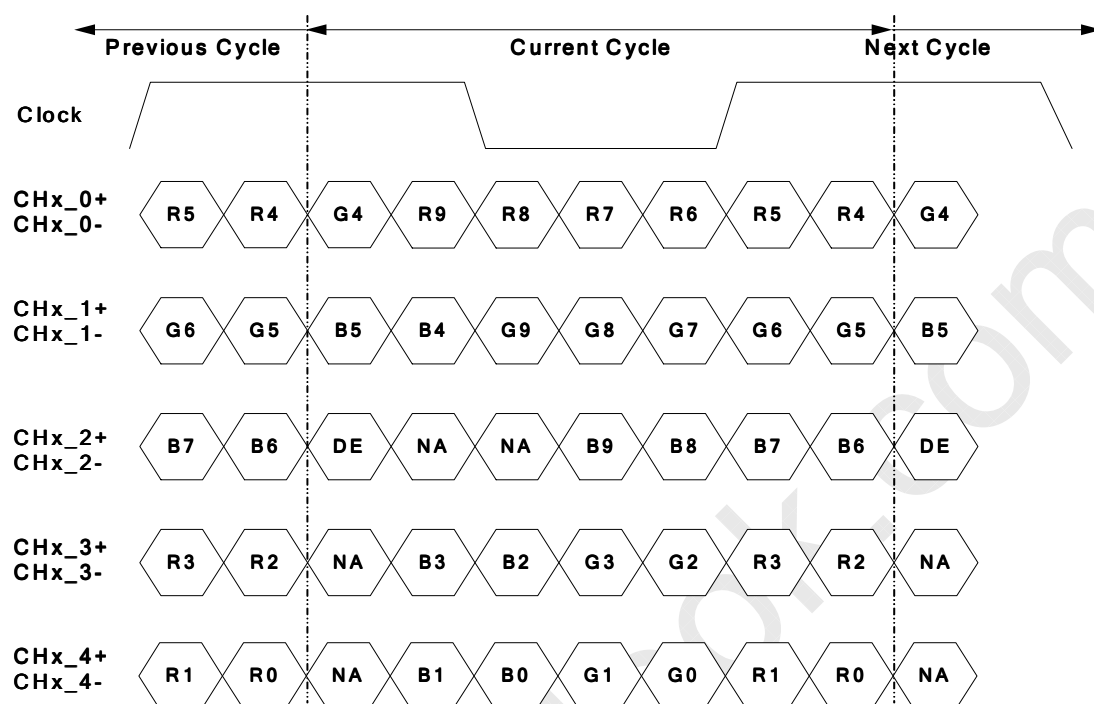
**LVDS Option = JEIDA**

Note: x = 1, 2, 3, 4...

### 3.3 Signal Timing Specification

This is the signal timing required at the input of the user connector. All of the interface signal timing should be satisfied with the following specifications for its proper operation.

#### Timing Table (DE only Mode)

Signal	Item	Symbol	Typ.1 (typical)	Typ.2	Typ.3	Unit
Vertical Section	Period	Tv	1134	1360	1416	Th
	Active	Tdisp (v)	1080			Th
	Blanking	Tblk (v)	54	280	336	Th
Horizontal Section	Period	Th	1092	1092	1092	Tclk
	Active	Tdisp (h)	960			Tclk
	Blanking	Tblk (h)	132	132	132	Tclk
Clock	Frequency	Fclk=1/Tclk	74.3	74.26	74.22	MHz
Vertical Frequency	Frequency	Fv	60	50	48	Hz
Horizontal Frequency	Frequency	Fh	68	68	68	KHz

#### Notes:

- (1) Display position is specific by the rise of DE signal only.  
Horizontal display position is specified by the rising edge of 1<sup>st</sup> DCLK after the rise of 1<sup>st</sup> DE, is displayed on the left edge of the screen.
- (2) Vertical display position is specified by the rise of DE after a "Low" level period equivalent to eight times of horizontal period. The 1<sup>st</sup> data corresponding to one horizontal line after the rise of 1<sup>st</sup> DE is displayed at the top line of screen.
- (3) If a period of DE "High" is less than 1366 DCLK or less than 768 lines, the rest of the screen displays black.
- (4) The display position does not fit to the screen if a period of DE "High" and the effective data period do not synchronize with each other.

### 3.4 Signal Timing Waveforms

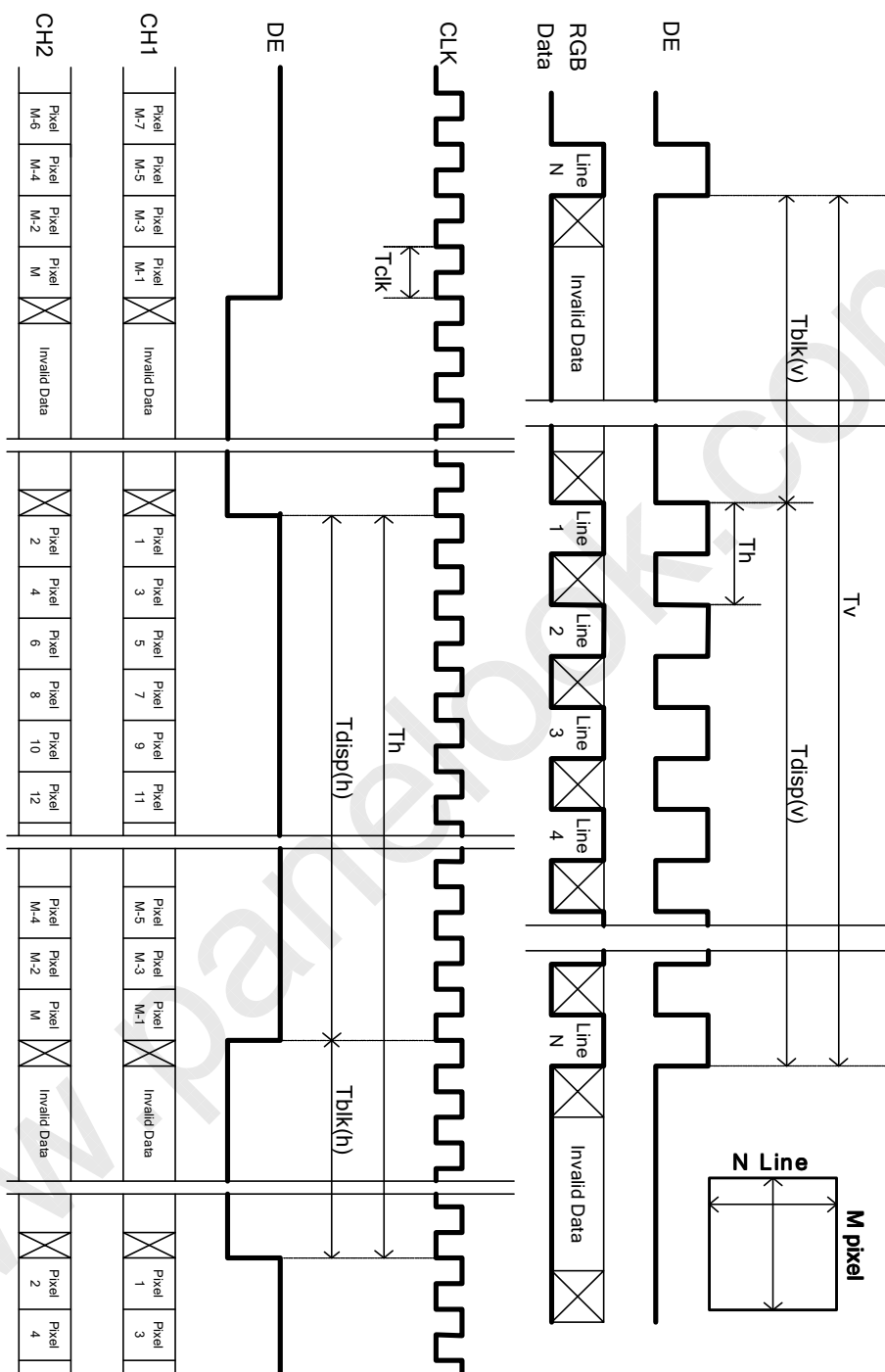



### 3.5 Color Input Data Reference

The brightness of each primary color (red, green and blue) is based on the 10 bit gray scale data input for the color; the higher the binary input, the brighter the color. The table below provides a reference for color versus data input.

#### COLOR DATA REFERENCE

Color		Input Color Data																													
		RED										GREEN										BLUE									
		MSB					LSB					MSB					LSB					MSB				LSB					
		R9	R8	R7	R6	R5	R4	R3	R2	R1	R0	G9	G8	G7	G6	G5	G4	G3	G2	G1	G0	B9	B8	B7	B6	B5	B4	B3	B2	B1	B0
Basic Color	Black	0	0	0	0	0	0	0	0	0	0	0	0	0	0	0	0	0	0	0	0	0	0	0	0	0	0	0	0	0	0
	Red(1023)	1	1	1	1	1	1	1	1	1	1	0	0	0	0	0	0	0	0	0	0	0	0	0	0	0	0	0	0	0	0
	Green(1023)	0	0	0	0	0	0	0	0	0	0	1	1	1	1	1	1	1	1	1	1	0	0	0	0	0	0	0	0	0	0
	Blue(1023)	0	0	0	0	0	0	0	0	0	0	0	0	0	0	0	0	0	0	0	0	1	1	1	1	1	1	1	1	1	1
	Cyan	0	0	0	0	0	0	0	0	0	0	1	1	1	1	1	1	1	1	1	1	1	1	1	1	1	1	1	1	1	1
	Magenta	1	1	1	1	1	1	1	1	1	1	0	0	0	0	0	0	0	0	0	0	1	1	1	1	1	1	1	1	1	1
	Yellow	1	1	1	1	1	1	1	1	1	1	1	1	1	1	1	1	1	1	1	1	0	0	0	0	0	0	0	0	0	0
	White	1	1	1	1	1	1	1	1	1	1	1	1	1	1	1	1	1	1	1	1	1	1	1	1	1	1	1	1	1	1
R	RED(000)	0	0	0	0	0	0	0	0	0	0	0	0	0	0	0	0	0	0	0	0	0	0	0	0	0	0	0	0	0	
	RED(001)	0	0	0	0	0	0	0	0	0	0	0	0	0	0	0	0	0	0	0	0	0	0	0	0	0	0	0	0	0	
	----																														
	RED(1022)	1	1	1	1	1	1	1	1	1	0	0	0	0	0	0	0	0	0	0	0	0	0	0	0	0	0	0	0	0	
	RED(1023)	1	1	1	1	1	1	1	1	1	0	0	0	0	0	0	0	0	0	0	0	0	0	0	0	0	0	0	0	0	
G	GREEN(000)	0	0	0	0	0	0	0	0	0	0	0	0	0	0	0	0	0	0	0	0	0	0	0	0	0	0	0	0	0	
	GREEN(001)	0	0	0	0	0	0	0	0	0	0	0	0	0	0	0	0	0	0	0	0	0	0	0	0	0	0	0	0	0	
	----																														
	GREEN(1022)	0	0	0	0	0	0	0	0	0	1	1	1	1	1	1	1	1	1	1	0	0	0	0	0	0	0	0	0	0	
	GREEN(1023)	0	0	0	0	0	0	0	0	0	1	1	1	1	1	1	1	1	1	1	0	0	0	0	0	0	0	0	0	0	
B	BLUE(000)	0	0	0	0	0	0	0	0	0	0	0	0	0	0	0	0	0	0	0	0	0	0	0	0	0	0	0	0	0	
	BLUE(001)	0	0	0	0	0	0	0	0	0	0	0	0	0	0	0	0	0	0	0	0	0	0	0	0	0	0	0	0	1	
	----																														
	BLUE(1022)	0	0	0	0	0	0	0	0	0	0	0	0	0	0	0	0	0	0	0	1	1	1	1	1	1	1	1	1	0	
	BLUE(1023)	0	0	0	0	0	0	0	0	0	0	0	0	0	0	0	0	0	0	0	1	1	1	1	1	1	1	1	1	1	



### 3.6 Power Sequence for LCD

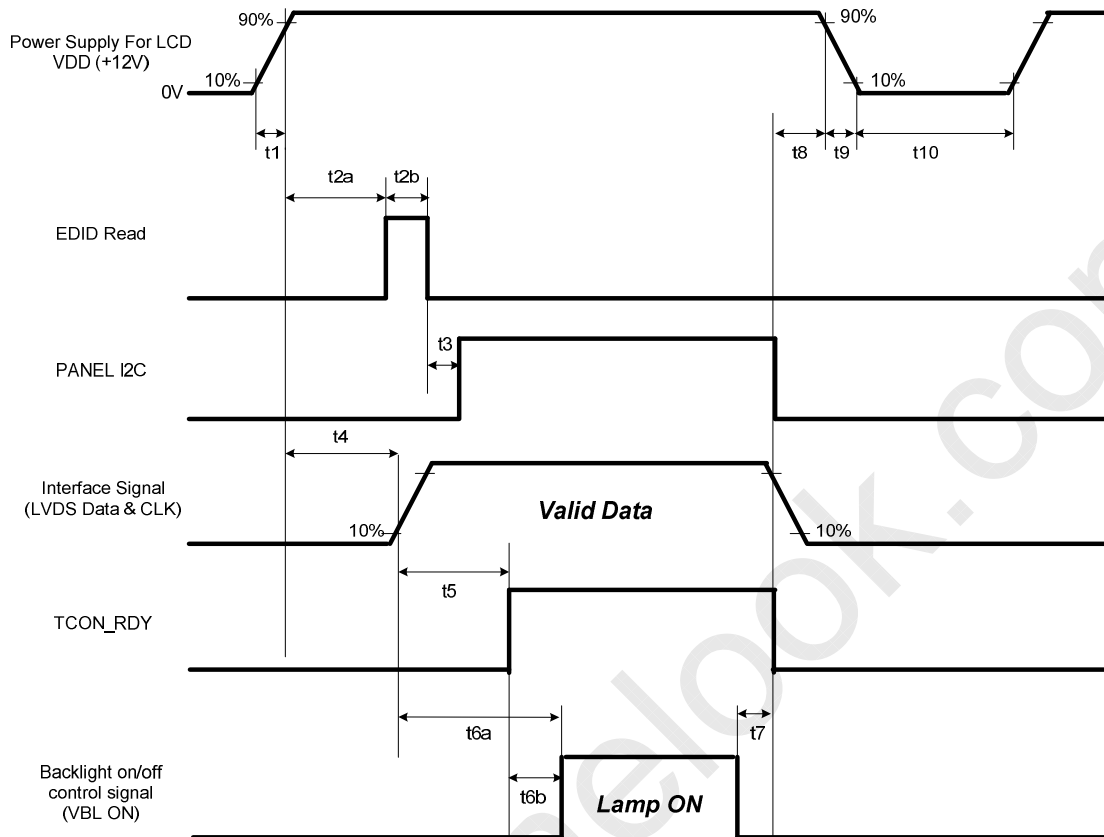

Parameter	Standard <sup>*1</sup>			Standalone <sup>*1</sup>	Unit
	Min.	Type.	Max.	Type.	
t1	0.47	---	30	---	ms
t2a	20	---	100	---	ms
t2b	0 <sup>*4</sup>	---	100 <sup>*4</sup>	---	ms
t3	60	---	---	---	ms
t4	20	---	---	---	ms
t5	680 <sup>*4</sup>	---	1160 <sup>*4</sup>	---	ms
t4+t5	---	---	---	<b>51</b>	ms
t6a	---	---	---	---	ms
t6b	500	---	---	---	ms
t7	100 <sup>*2</sup>	---	---	---	ms
t8	---	---	---	---	ms
t9	0 <sup>*3</sup>	---	300 <sup>*3</sup>	---	ms
t10	1000	---	---	---	ms

Note:

- (1) Standard mode is used for customer's operation. Standalone mode is used for panel factory operation.
- (2)  $t_7=0$ : concern for residual pattern before BLU turn off.
- (3)  $t_9$ : voltage of VDD must decay smoothly after power-off. (customer system decide this value)
- (4)  $t_{2b}$ ,  $t_5$  and  $t_9$ : customer decides this value

### 3.7 Backlight Specification

The backlight unit contains 4pcs light bar.

#### 3.7.1 Light bar Driven Condition

Parameter	Symbol	Values			Unit	Note
		Min	Typ	Max		
Forward Current (one light bar)	Anode	IF (anode)		120		mA
	Cathode	IF (cathode)		120	126	mA
Peak Forward Current		IFP			500	mA <1msec.
Forward Voltage		VF	140.8	145.2	154.0	V
Total Power Consumption (4 light bars)		PBL		69.7	73.18	W

### 3.7.2 Input Pin Assignment

	P1 -4pin		P2 - 5pin
1	#1 Anode	1	#1 Cathode (120mA)
2	#2 Anode	2	#2 Cathode (120mA)
3	#3 Anode	3	NC
4	#4 Anode	4	#3 Cathode (120mA)
		5	#4 Cathode (120mA)

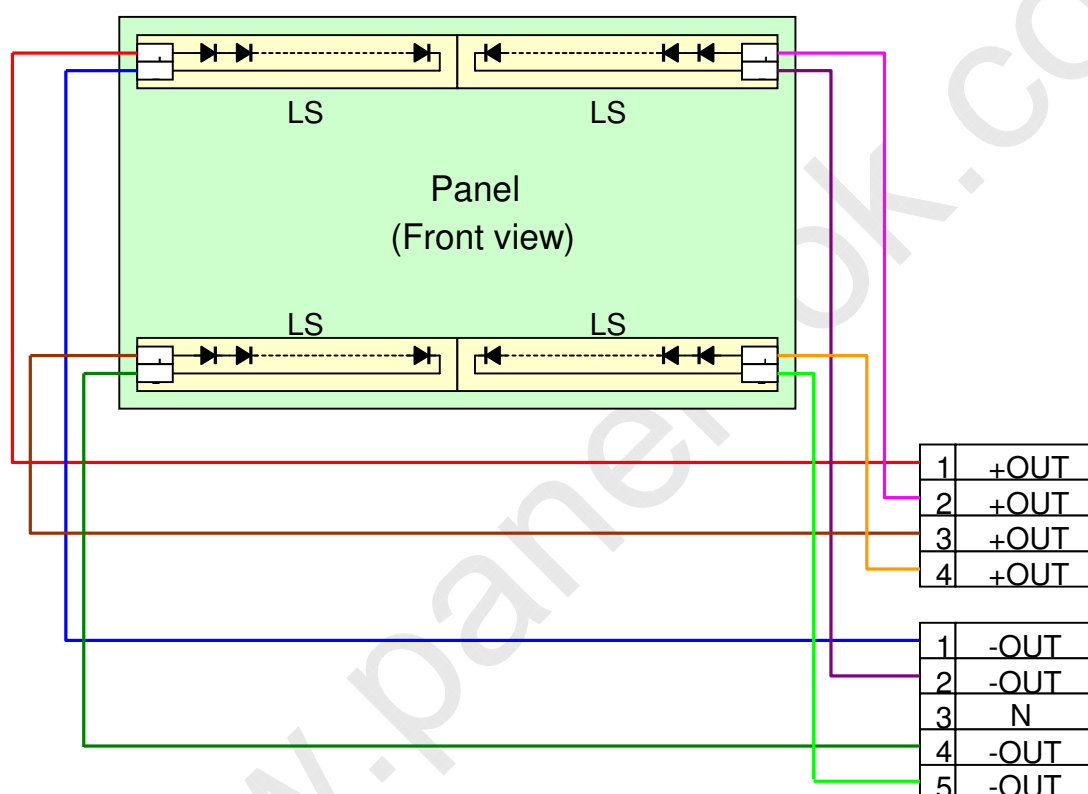

## 4. Optical Specification

Optical characteristics are determined after the unit has been 'ON' and stable for approximately 45 minutes in a dark environment at 25°C. The values specified are at an approximate distance 50cm from the LCD surface at a viewing angle of  $\phi$  and  $\theta$  equal to 0°.

Fig.1 presents additional information concerning the measurement equipment and method.

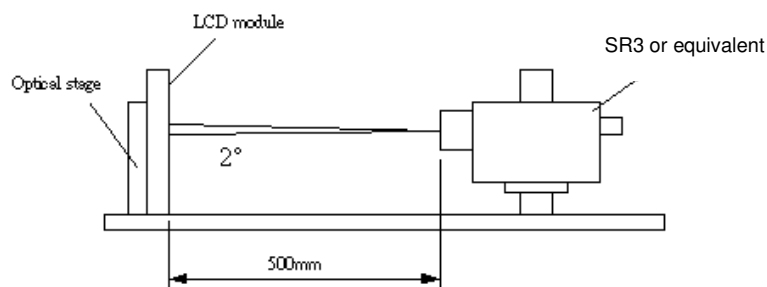

Parameter	Symbol	Values			Unit	Notes
		Min.	Typ.	Max		
Contrast Ratio	CR	4000	5000	--		1
Surface Luminance (White)	$L_{WH}$	360	450	--	cd/m <sup>2</sup>	2
Luminance Variation	$\delta_{WHITE(9P)}$	--	--	1.33		3
Response Time (G to G)	$T_{\gamma}$	--	5.5	--	Ms	4
Color Gamut	NTSC		72		%	
Color Coordinates						
Red	$R_x$	Typ.-0.03	0.630	Typ.+0.03		
	$R_y$		0.330			
Green	$G_x$		0.320			
	$G_y$		0.620			
Blue	$B_x$		0.150			
	$B_y$		0.040			
White	$W_x$		0.280			
	$W_y$		0.290			
Viewing Angle						5
x axis, right( $\phi=0^\circ$ )	$\theta_r$	--	89	--	degree	
x axis, left( $\phi=180^\circ$ )	$\theta_l$	--	89	--	degree	
y axis, up( $\phi=90^\circ$ )	$\theta_u$	--	89	--	degree	
y axis, down ( $\phi=270^\circ$ )	$\theta_d$	--	89	--	degree	

Note:

1. Contrast Ratio (CR) is defined mathematically as:

$$\text{Contrast Ratio} = \frac{\text{Surface Luminance of } L_{\text{on5}}}{\text{Surface Luminance of } L_{\text{off5}}}$$

2. Surface luminance is luminance value at point 5 across the LCD surface 50cm from the surface with all pixels displaying white. From more information see FIG 2. LED current  $I_F$  = typical value,  $L_{\text{WH}} = L_{\text{on5}}$  where  $L_{\text{on5}}$  is the luminance with all pixels displaying white at center 5 location.

3. The variation in surface luminance,  $\delta_{\text{WHITE}}$  is defined (center of Screen) as:

$$\delta_{\text{WHITE(9P)}} = \text{Maximum}(L_{\text{on1}}, L_{\text{on2}}, \dots, L_{\text{on9}}) / \text{Minimum}(L_{\text{on1}}, L_{\text{on2}}, \dots, L_{\text{on9}})$$

4. Response time  $T_\gamma$  is the average time required for display transition by switching the input signal for five luminance ratio (0%,25%,50%,75%,100% brightness matrix) and is based on  $F_v=60\text{Hz}$  to optimize.

Measured Response Time		Target				
		0%	25%	50%	75%	100%
Start	0%		0% to 25%	0% to 50%	0% to 75%	0% to 100%
	25%	25% to 0%		25% to 50%	25% to 75%	25% to 100%
	50%	50% to 0%	50% to 25%		50% to 75%	50% to 100%
	75%	75% to 0%	75% to 25%	75% to 50%		75% to 100%
	100%	100% to 0%	100% to 25%	100% to 50%	100% to 75%	

$T_\gamma$  is determined by 10% to 90% brightness difference of rising or falling period. (As illustrated)

The response time is defined as the following figure and shall be measured by switching the input signal for "any level of gray(bright)" and "any level of gray(dark)".

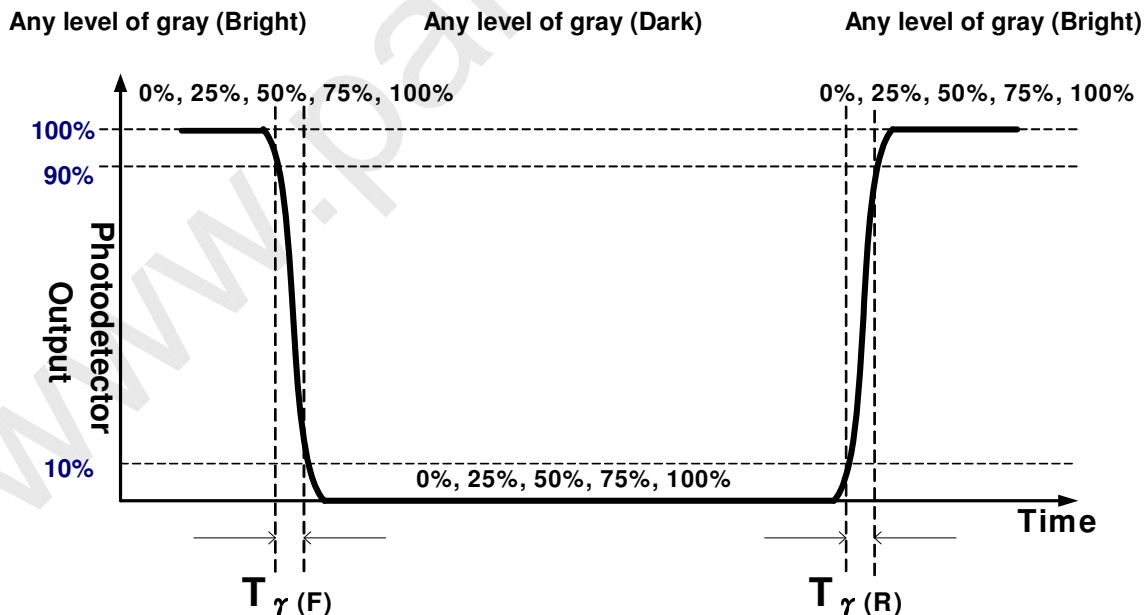

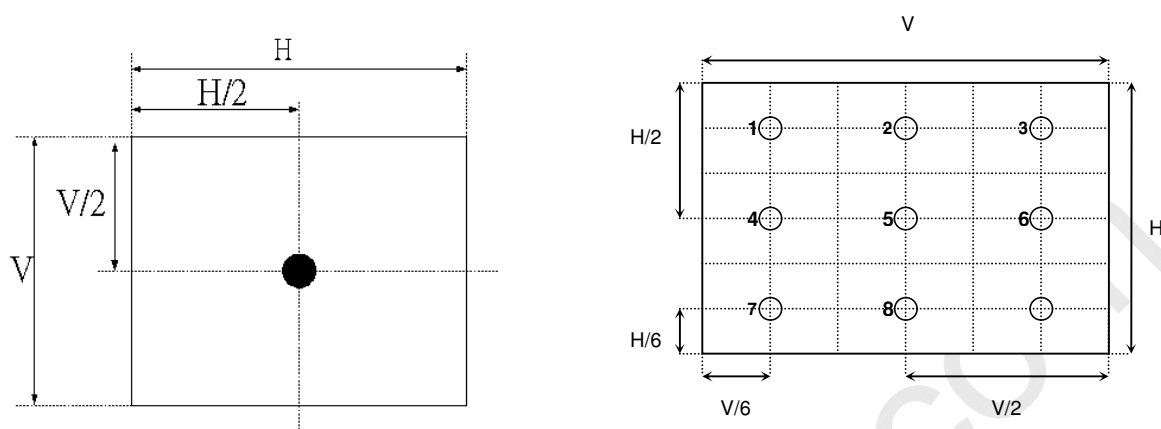
**FIG. 2 Luminance**

5. Viewing angle is the angle at which the contrast ratio is greater than 10. The angles are determined for the horizontal or x axis and the vertical or y axis with respect to the z axis which is normal to the LCD surface. For more information see FIG3.

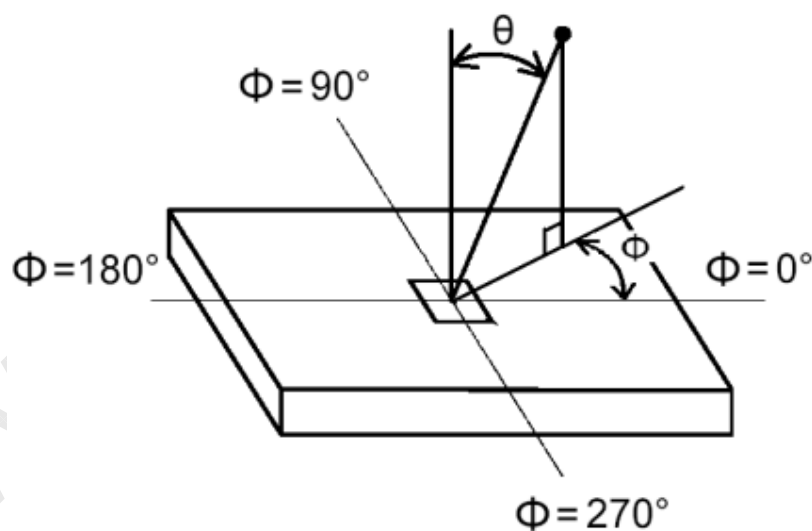
**FIG.3 Viewing Angle**

## 5. Mechanical Characteristics

The contents provide general mechanical characteristics for the model T400HW04 V1. In addition the figures in the next page are detailed mechanical drawing of the LCD.

Item		Dimension	Unit	Note
Outline Dimension	Horizontal	921.7	mm	
	Vertical	537.8	mm	
	Depth (Dmin)	10.8	mm	to rear
	Depth (Dmax)	27.5	mm	to control board cover
Weight	7200		g	

## Front View

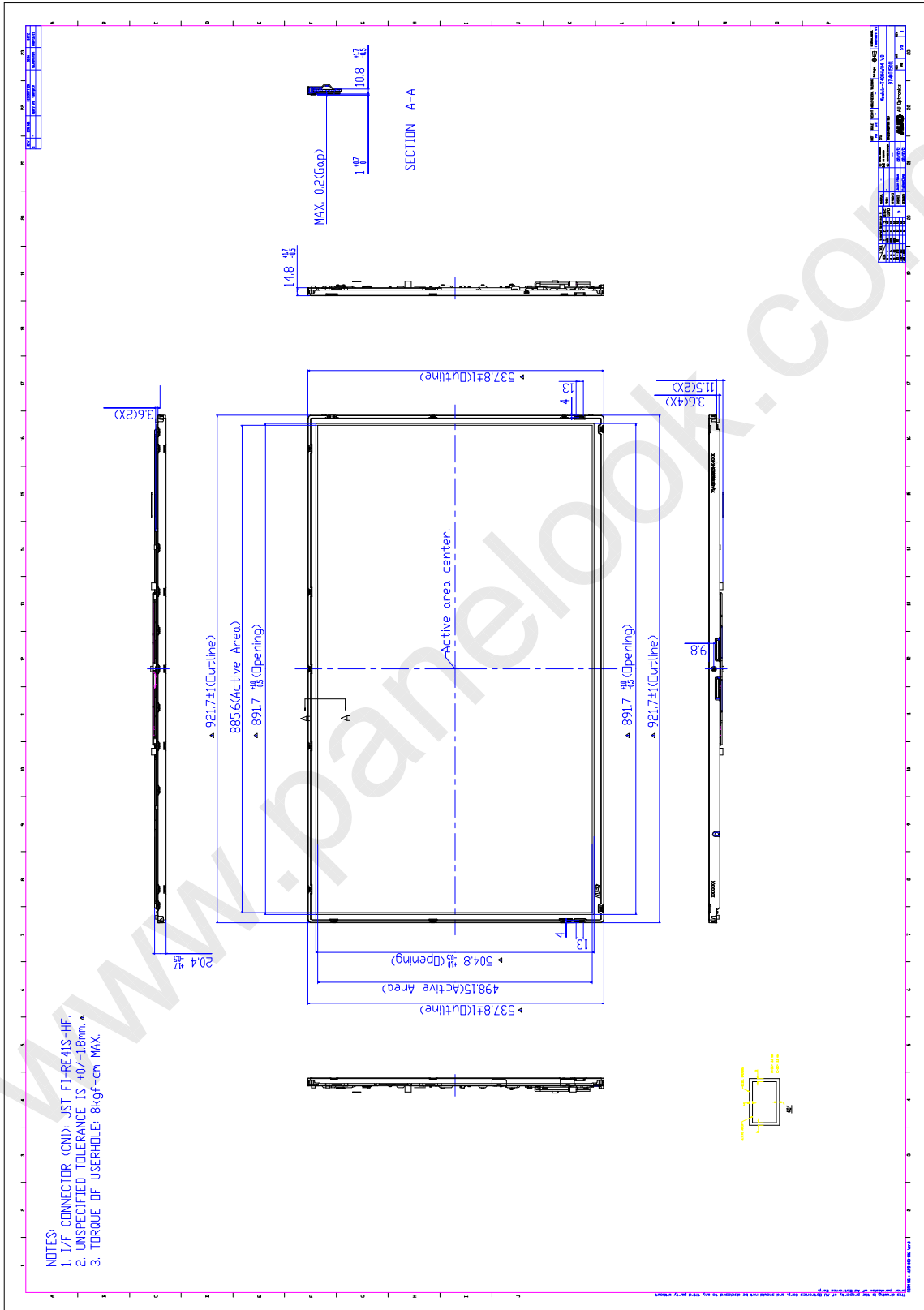



### Back View

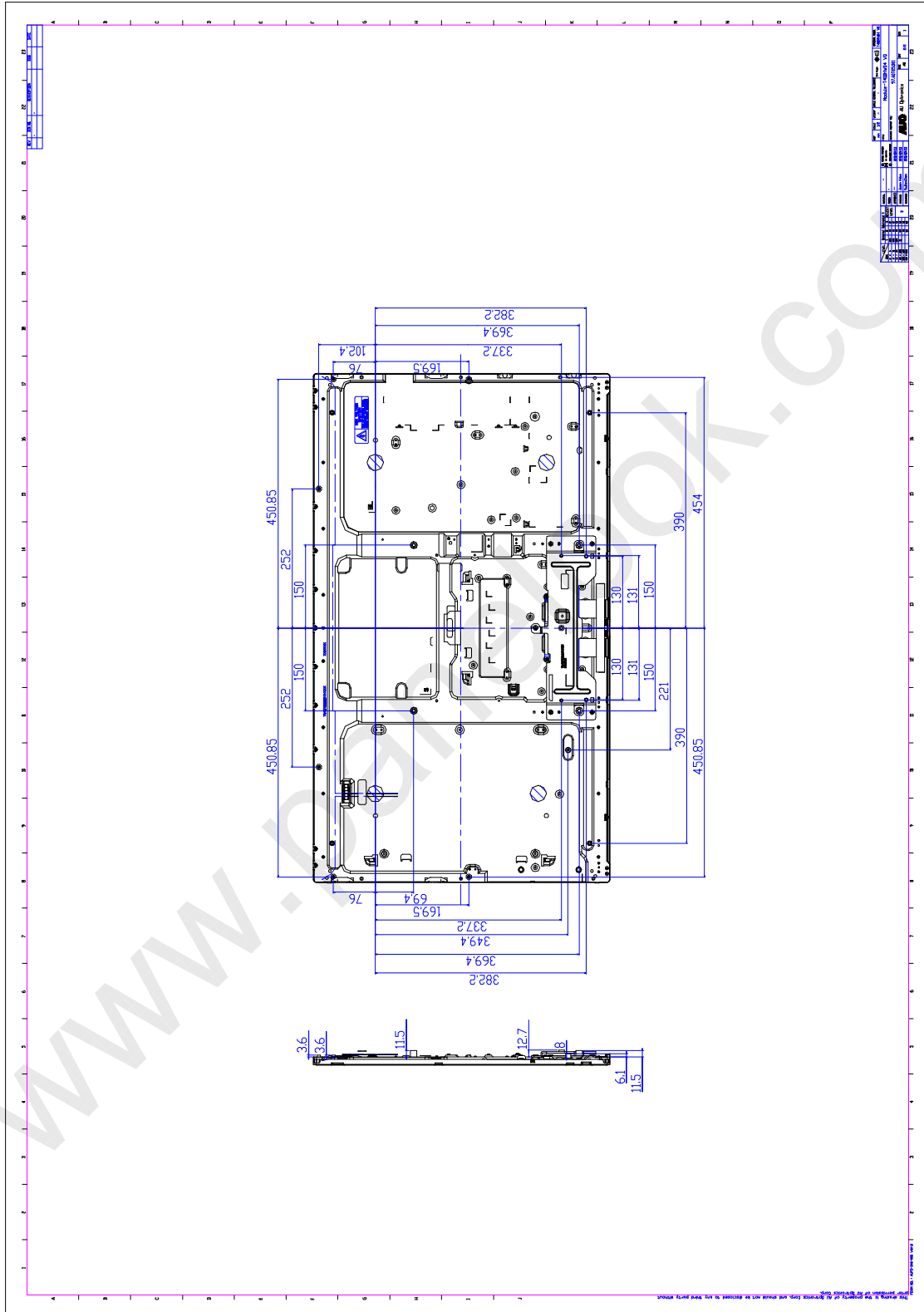

"Details of dimension depend on MIF (Mechanical Interface)."

## 6. Reliability Test Items

	Test Item	Q'ty	Condition
1	High temperature storage test	3	60°C, 300hrs
2	Low temperature storage test	3	-20°C, 300hrs
3	High temperature operation test	3	50°C, 300hrs
4	Low temperature operation test	3	-5°C, 300hrs
5	Vibration test (non-operation)	3	Wave form: random Vibration level : 1.0G RMS Bandwidth : 10-300Hz Duration : X,Y,Z 10min per axes X,Y,Z: Horizontal, face up
6	Shock test (non-operation)	3	Shock level 50G, 11 ms in ±X,Y,Z axis Waveform: half sine wave Direction: One time each direction
7	Vibration test (With carton)	3	Random wave (1.05Grms 10~200Hz) Duration : X,Y,Z 10min per axes
8	Drop test (With carton)	3	Height: 254mm (ASTMD4169-I) 1(refer ASTM D 5276) Front flat→ rear flat→ left flat→ right flat → bottom flat→ bottom flat (2 <sup>nd</sup> time)

## 7. International Standard

### 7.1 Safety

- (1) UL 60950-1, UL 60065; Standard for Safety of Information Technology Equipment Including electrical Business Equipment.
- (2) IEC 60950-1 : 2001, IEC 60065:2001 ; Standard for Safety of International Electrotechnical Commission
- (3) EN 60950 : 2001+A11, EN 60065:2002+A1:2006; European Committee for Electrotechnical Standardization (CENELEC), EUROPEAN STANDARD for Safety of Information Technology Equipment Including Electrical Business Equipment.

### 7.2 EMC

- (1) ANSI C63.4 "Methods of Measurement of Radio-Noise Emissions from Low-Voltage Electrical and Electrical Equipment in the Range of 9kHz to 40GHz. "American National standards Institute(ANSI), 1992
- (2) C.I.S.P.R "Limits and Methods of Measurement of Radio Interface Characteristics of Information Technology Equipment." International Special committee on Radio Interference.
- (3) EN 55022 "Limits and Methods of Measurement of Radio Interface Characteristics of Information Technology Equipment." European Committee for Electrotechnical Standardization. (CENELEC), 1998

## 8. Packing

### 8-1 DEFINITION OF LABEL:

#### A. Panel Label:

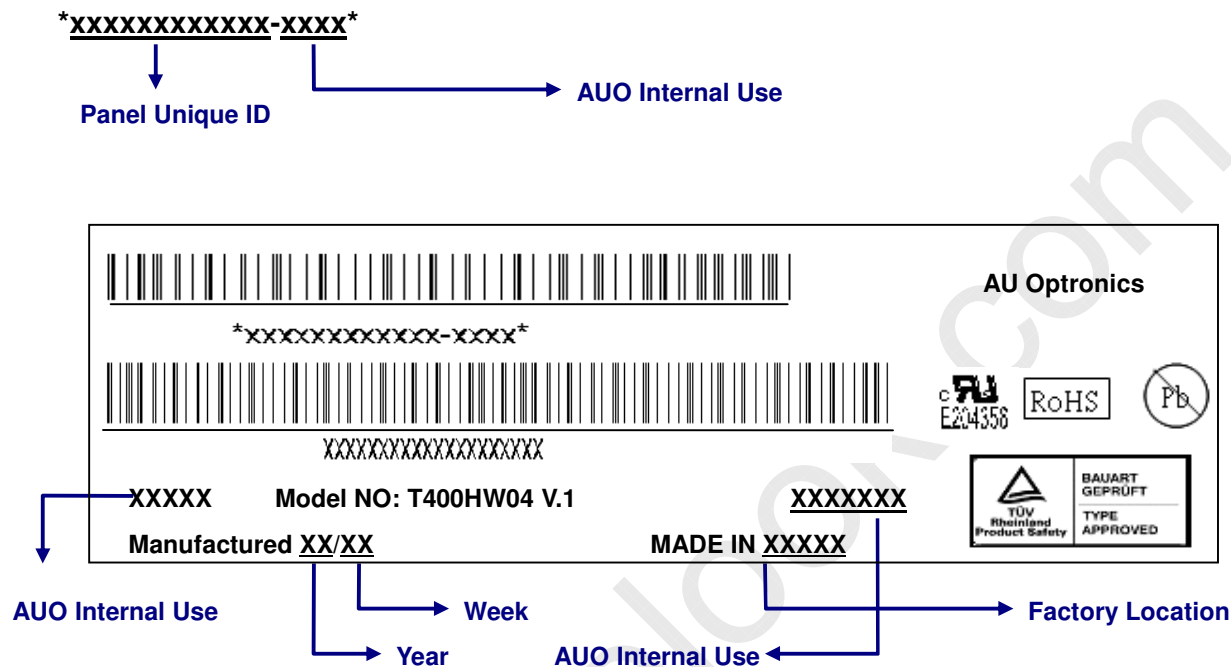

#### Green mark description

(1) For Pb Free Product, AUO will add  for identification.

(2) For RoHs compatible products, AUO will add  for identification.

Note: The green Mark will be present only when the green documents have been ready by AUO internal green team. (definition of green design follows the AUO green design checklist.)

#### B. Carton Label:

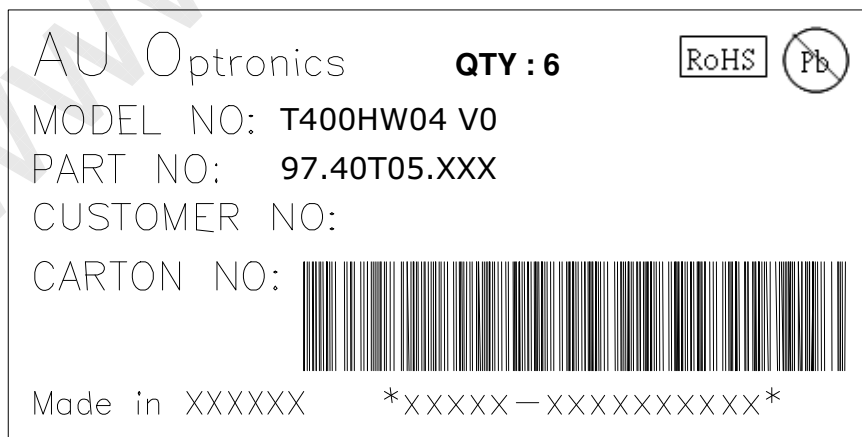

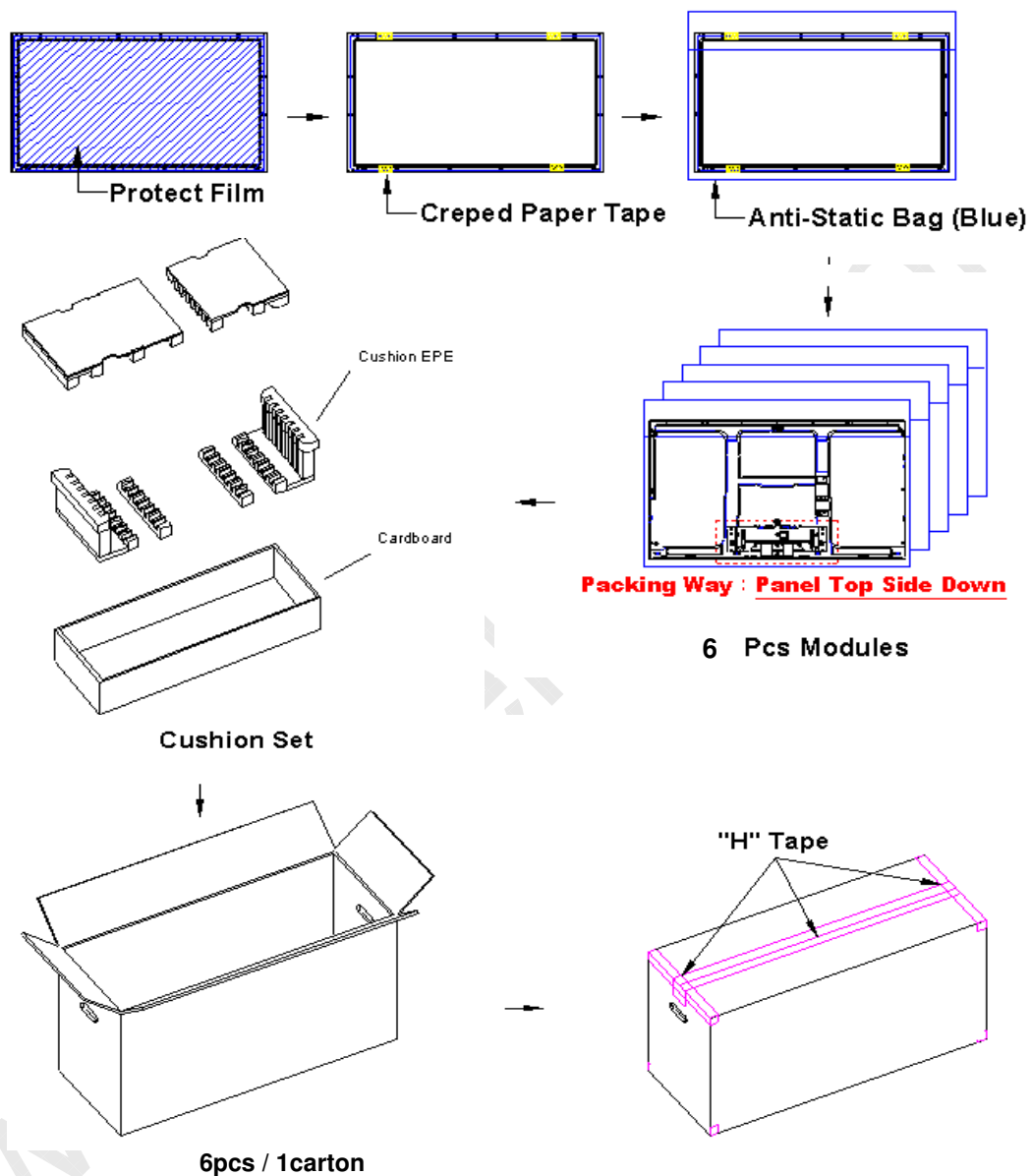
**8-2 PACKING METHODS:**

**8-3 Pallet and Shipment Information**

	Item	Specification			Packing Remark
		Qty.	Dimension	Weight (kg)	
1	Packing BOX	6pcs/box	1020(L)*375(W)*615(H)	55	Box = 3.2 kg Cushion = 0.9kg
2	Pallet	1	1150(L)*1070(W)*135(H)	16	
3	Boxes per Pallet	3 boxes/pallet			
4	Panels per Pallet	18pcs/pallet			
	Pallet after packing	18	1150(L)*1070(W)*750(H)	181	

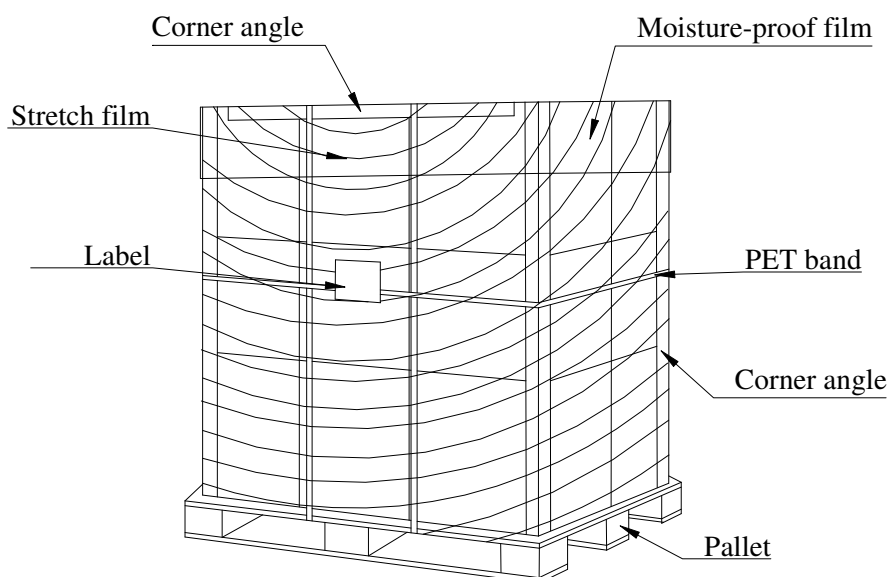

## 9. PRECAUTIONS

Please pay attention to the followings when you use this TFT LCD module.

### 9-1 MOUNTING PRECAUTIONS

- (1) You must mount a module using holes arranged in four corners or four sides.
- (2) You should consider the mounting structure so that uneven force (ex. twisted stress) is not applied to module. And the case on which a module is mounted should have sufficient strength so that external force is not transmitted directly to the module.
- (3) Please attach the surface transparent protective plate to the surface in order to protect the polarizer. Transparent protective plate should have sufficient strength in order to resist external force.
- (4) You should adopt radiation structure to satisfy the temperature specification.
- (5) Acetic acid type and chlorine type materials for the cover case are not desirable because the former generates corrosive gas of attacking the polarizer at high temperature and the latter cause circuit broken by electro-chemical reaction.
- (6) Do not touch, push or rub the exposed polarizer with glass, tweezers or anything harder than HB pencil lead. And please do not rub with dust clothes with chemical treatment. Do not touch the surface of polarizer for bare hand or greasy cloth. (Some cosmetics are detrimental to the polarizer.)
- (7) When the surface becomes dusty, please wipe gently with absorbent cotton or other soft materials like chamois soaks with petroleum benzene. Normal-hexane is recommended for cleaning the adhesives used to attach front/ rear polarizer. Do not use acetone, toluene and alcohol because they cause chemical damage to the polarizer.
- (8) Wipe off saliva or water drops as soon as possible. Their long time contact with polarizer causes deformations and color fading.
- (9) Do not open the case because inside circuits do not have sufficient strength.

### 9-2 OPERATING PRECAUTIONS

- (1) The device listed in the product specification sheets was designed and manufactured for TV application
- (2) The spike noise causes the mis-operation of circuits. It should be lower than following voltage:  
 $V = \pm 200\text{mV}$  (Over and under shoot voltage)
- (3) Response time depends on the temperature. (In lower temperature, it becomes longer..)
- (4) Brightness of CCFL depends on the temperature. (In lower temperature, it becomes lower.) And in lower temperature, response time (required time that brightness is stable after turned on) becomes longer.
- (5) Be careful for condensation at sudden temperature change. Condensation makes damage to polarizer or electrical contacted parts. And after fading condensation, smear or spot will occur.
- (6) When fixed patterns are displayed for a long time, remnant image is likely to occur.
- (7) Module has high frequency circuits. Sufficient suppression to the electromagnetic interference shall

be done by system manufacturers. Grounding and shielding methods may be important to minimize the interface.

### **9-3 ELECTROSTATIC DISCHARGE CONTROL**

Since a module is composed of electronic circuits, it is not strong to electrostatic discharge. Make certain that treatment persons are connected to ground through wristband etc. And don't touch interface pin directly.

### **9-4 PRECAUTIONS FOR STRONG LIGHT EXPOSURE**

Strong light exposure causes degradation of polarizer and color filter.

### **9-5 STORAGE**

When storing modules as spares for a long time, the following precautions are necessary.

- (1) Store them in a dark place. Do not expose the module to sunlight or fluorescent light. Keep the temperature between 5°C and 35°C at normal humidity.
- (2) The polarizer surface should not come in contact with any other object. It is recommended that they be stored in the container in which they were shipped.

### **9-6 HANDLING PRECAUTIONS FOR PROTECTION FILM**

- (1) The protection film is attached to the bezel with a small masking tape. When the protection film is peeled off, static electricity is generated between the film and polarizer. This should be peeled off slowly and carefully by people who are electrically grounded and with well ion-blown equipment or in such a condition, etc.
- (2) When the module with protection film attached is stored for a long time, sometimes there remains a very small amount of glue still on the bezel after the protection film is peeled off.
- (3) You can remove the glue easily. When the glue remains on the bezel or its vestige is recognized, please wipe them off with absorbent cotton waste or other soft material like chamois soaked with normal-hexane.



## Appendix

Item	Description	Value																																
<b>Vendor code</b>	Vendor Code 0 : - 1 : AUO	<b>1</b>																																
<b>Panel Inch</b>	Panel Inch, setting function: 21.6inch= 22 / 26inch= 26 / 24inch= 24 32inch= 32 / 37inch= 37 40inch= 40 / 42inch= 42 46inch= 46 / 52inch= 52	<b>40</b>																																
<b>H.Resolution</b>	Panel Horizontal resolution information. 16bit : 0x02 = MS Byte, 0x03 = LS Byte (1) Horizontal resolution = 3840 (2) Horizontal resolution = 1920 (3) Horizontal resolution = 1366	<b>1920</b>																																
<b>V.Resolution</b>	Panel Vertical Resolution information: 16bit : 0x04 = MS Byte, 0x05 = LS Byte (1) Vertical resolution = 2160 (2) Vertical resolution = 1080 (3) Vertical resolution = 768	<b>1080</b>																																
<b>V. Frequency</b>	Panel Vertical frequency information. 0: 50Hz / 60Hz 1: 100Hz / 120Hz 2: 200Hz / 240Hz	<b>1</b>																																
<b>Data format</b>	Panel LVDS Data format information. 0: 6bit / 1: 8bit 2: 10bit / 3: 12bit 4: 14bit / 5: 16bit	<b>2</b>																																
<b>Part Number</b>	<b>Panel maker's version information.</b> <b>@ Example: T260XW05 V0</b> <b>Item: (0), (1), (2), (3), (4), (5), (6), (7), (8), (9), (10), (11)</b> <b>"T", "2", "6", "0", "X", "W", "0", "5", "", "V", "0", "0"</b>	<table border="1"> <thead> <tr> <th>0</th><th>1</th><th>2</th><th>3</th><th>4</th><th>5</th><th>6</th><th>7</th><th>8</th><th>9</th><th>10</th><th>11</th><th>12</th><th>13</th><th>14</th><th>15</th> </tr> </thead> <tbody> <tr> <td>T</td><td>4</td><td>0</td><td>0</td><td>H</td><td>W</td><td>0</td><td>4</td><td></td><td>V</td><td>1</td><td></td><td></td><td></td><td></td><td></td> </tr> </tbody> </table> <b>Capitalization</b>	0	1	2	3	4	5	6	7	8	9	10	11	12	13	14	15	T	4	0	0	H	W	0	4		V	1					
0	1	2	3	4	5	6	7	8	9	10	11	12	13	14	15																			
T	4	0	0	H	W	0	4		V	1																								

### i. EMI specification

Model name: T400HW04 V1

Item	Min	Typ	Max	Unit
EMI level (Note)	---	---	-6	dB( $\mu$ V/m)
SSCG	---	<b>300</b>	---	ps

Note:

甲、Criteria: CISPR22

乙、Signal generator: PSG400 (Sony EMCS)

丙、EMI site: Sony EMCS Ichinomiya Tec. or using correlation value

丁、Find result should be checked by connecting with TV-set