



2007/05/09

## Product Specifications

**40" WXGA Color TFT-LCD Module**

**Model Name: T400XW01. V1**

0

0 Preliminary Specifications

(\* Final Specifications



## Contents

No	
	CONTENTS
	RECORD OF REVISIONS
1	GENERAL DESCRIPTION
2	ABSOLUTE MAXIMUM RATINGS
3	ELECTRICAL CHARACTERISTICS
3-1	TFT-LCD MODULE
3-2	BACKLIGHT UNIT
3-3	LVDS DATA FORMAT
4	INPUT TERMINAL PIN ASSIGNMENT
4-1	TFT-LCD MODULE
4-2	INVERTER UNIT
4-3	LVDS DATA FORMAT
4-4	COLOR DATA INPUT ASSIGNMENT
5	INTERFACE TIMING CHARACTERISTICS
6	OPTICAL CHARACTERISTICS
7	MECHANICAL CHARACTERISTICS
8	RELIABILITY
9	INTERNATIONAL STANDARDS
9-1	SAFETY
9-2	EMC
10	PACKING
10-1	LABEL DEFINITION
10-2	PACKING METHODS & SPECIFICATIONS
11	PRECAUTIONS



### Record of Revision

Version	Date	No	Old Description	New Description	Remark

www.panelook.com



## 1. General Description

This specification applies to the 40.0 inch Color TFT-LCD Module T400XW01 V1. This LCD module has a TFT active matrix type liquid crystal panel 1366x768 pixels, and diagonal size of 40.0 inch. This module supports 1366x768 HD-Ready mode.

Each pixel is divided into Red, Green and Blue sub-pixels or dots which are arranged in vertical stripes. Gray scale or the brightness of the sub-pixel color is determined with a 8-bit gray scale signal for each dot.

The T400XW01 V1 has been designed to apply the 8-bit 1 channel LVDS interface method. It is intended to support displays where high brightness, wide viewing angle, high color saturation, and high color depth are very important.

### \* General Information

Items	Specification	Unit	Note
Active Screen Size	40.00	inch	
Display Area	885.168(H) x 497.00(V)	mm	
Outline Dimension	952.0(H) x 551.0 (V) x 48.4(D)	mm	With Balance board
Driver Element	a-Si TFT active matrix		
Display Colors	8 bit, 16.7M	Colors	
Number of Pixels	1366 x 768	Pixel	
Pixel Pitch	0.648(H) x 0.648(W)	mm	
Pixel Arrangement	RGB vertical stripe		
Display Operation Mode	Transmissive, Normally Black		
Surface Treatment	Hard-Coating (3H), Anti-Glare		



## 2. Absolute Maximum Ratings

The following are maximum values that, if exceeded, may cause permanent damage to the device.

Item	Symbol	Min	Max	Unit	Note
Logic/LCD Drive Voltage	Vcc	-0.3	6	[Volt]	[1]
Input Voltage of Signal	Vin	-0.3	4	[Volt]	[1]
Operating Temperature	TOP	0	50	[°C]	[2]
Operating Humidity	HOP	10	90	[%RH]	[2]
Storage Temperature	TST	-20	65	[°C]	[2]
Storage Humidity	HST	10	90	[%RH]	[2]

Note 1: Duration = 50msec

Note 2 : Maximum Wet-Bulb should be 39°C and No condensation.

Note 3: Temperature and relative humidity range is shown below

- Humidity 90%RH Max ( $T_a \leq 40^\circ\text{C}$ )
- Wet-bulb temperature  $\leq 39^\circ\text{C}$ . ( $T_a > 40^\circ\text{C}$ )
- No condensation

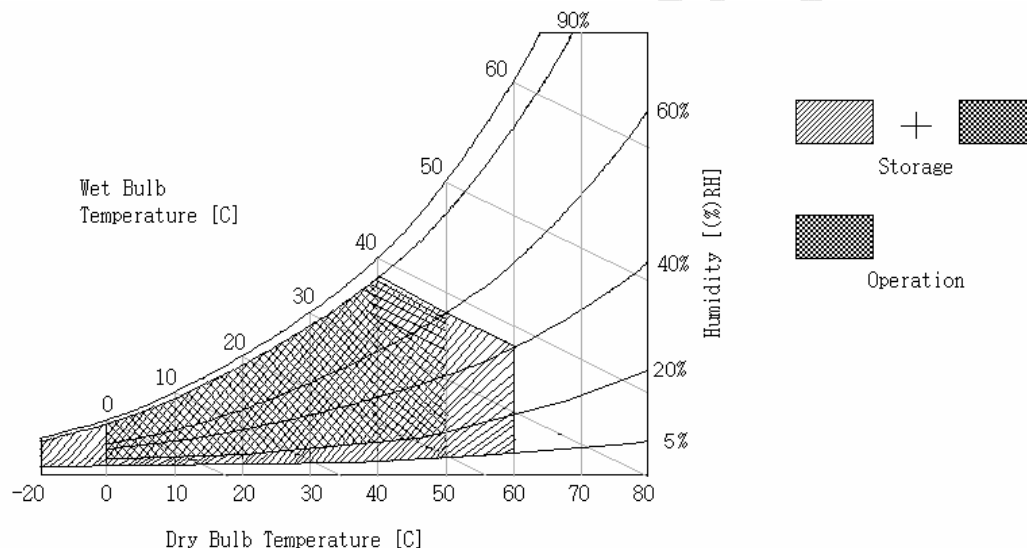



### 3. Electrical Characteristics

The T400XW01 V1 requires two power inputs.

1. 1<sup>st</sup> input power: for TFT-LCD Module driving.
2. 2<sup>nd</sup> input power: for the BLU driving, (powered inverter)

#### 3-1 TFT-LCD Module

( $T_a=25\pm 2^\circ\text{C}$ )

Parameter	Symbol	Values			Unit	Notes
		Min	Typ	Max		
Power Supply Input Voltage	V <sub>CC</sub>	4.5	5	5.5	V <sub>dc</sub>	
Power Supply Input Current	I <sub>CC</sub>	-	1.4		A	[1]
Power Consumption	P <sub>C</sub>	-	7		Watt	[1]
Inrush Current	I <sub>RUSH</sub>	-		4	A <sub>peak</sub>	[2]
LVDS Interface	Differential Input High Threshold Voltage	V <sub>TH</sub>		100	mV	[3]
	Differential Input Low Threshold Voltage	V <sub>TL</sub>	-100		mV	[3]
	Common Input Voltage	V <sub>ICM</sub>	1.0	1.2	1.5	V
CMOS Interface	Input High Threshold Voltage	V <sub>IH</sub> (High)	2.7	3.3	V <sub>dc</sub>	
	Input Low Threshold Voltage	V <sub>IL</sub> (Low)	0	0.6	V <sub>dc</sub>	

#### Note:

1. Testing condition is shown in table and figure below for electrical characteristic measurement:

	Symbol	Value	Units	Note
Input Voltage	V <sub>CC</sub>	5	Volt	
Vertical Frequency	f <sub>v</sub>	60	Hz	
Frequency of Clock	f <sub>CLK</sub>	65	MHz	
Inrush Current	I <sub>rush</sub>	4	A	
Time period with rush current	Δ t	470	us	Shown in Fig. 1
Common input Voltage	V <sub>ICM</sub>		V	
Test Pattern level	Level	L255		L255 White Pattern

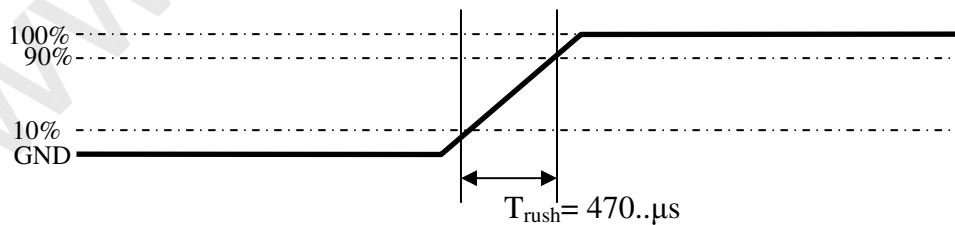

Figure 1: Measurement of I<sub>rush</sub>

2. Environment condition for electrical characteristic measurement::  
Temperature and relative humidity range is shown below:
  - A. Humidity 90%RH Max ( $T_a \leq 40^\circ\text{C}$ )
  - B. Wet-bulb temperature  $\leq 39^\circ\text{C}$ . ( $T_a > 40^\circ\text{C}$ )
  - C. No condensation



3. Measurement of LVDS differential voltage is shown in Figure 2.

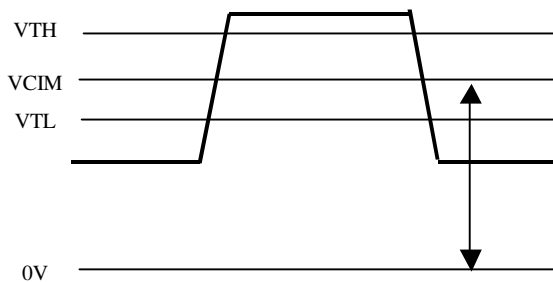

Figure 2 : LVDS Differential Voltage



### 3-2 BACKLIGHT UNIT

( $T_a=25\pm 2^\circ\text{C}$ )

Parameter	Symbol	Value			Units	Note
		Min	Typ.	Max		
Lamp Voltage	$V_L$		1475			
Lamp current	$P_L$	150	165	180		Typical value is for defining brightness
Life time	$L_L$	50000				

**Note:**

1. Do not attach a conducting tape to lamp connecting wire. If the lamp wire attach to conducting tape, TFT-LCD Module have a low luminance and the inverter has abnormal action because leakage current occurs between lamp wire and conducting tape.
2. The performance of the Lamp in LCM, for example lifetime or brightness, is extremely influenced by the input signal of Integrated Power board(I/P board). So all the parameters of integrated power board must be carefully designed so as not to produce too much leakage current and loading. When you design or order one New power board, please inform AUO and double check if the performance will be influenced by different balance board. When you confirm it, the LCD Assembly should be operated in the same condition as installed in your instrument.

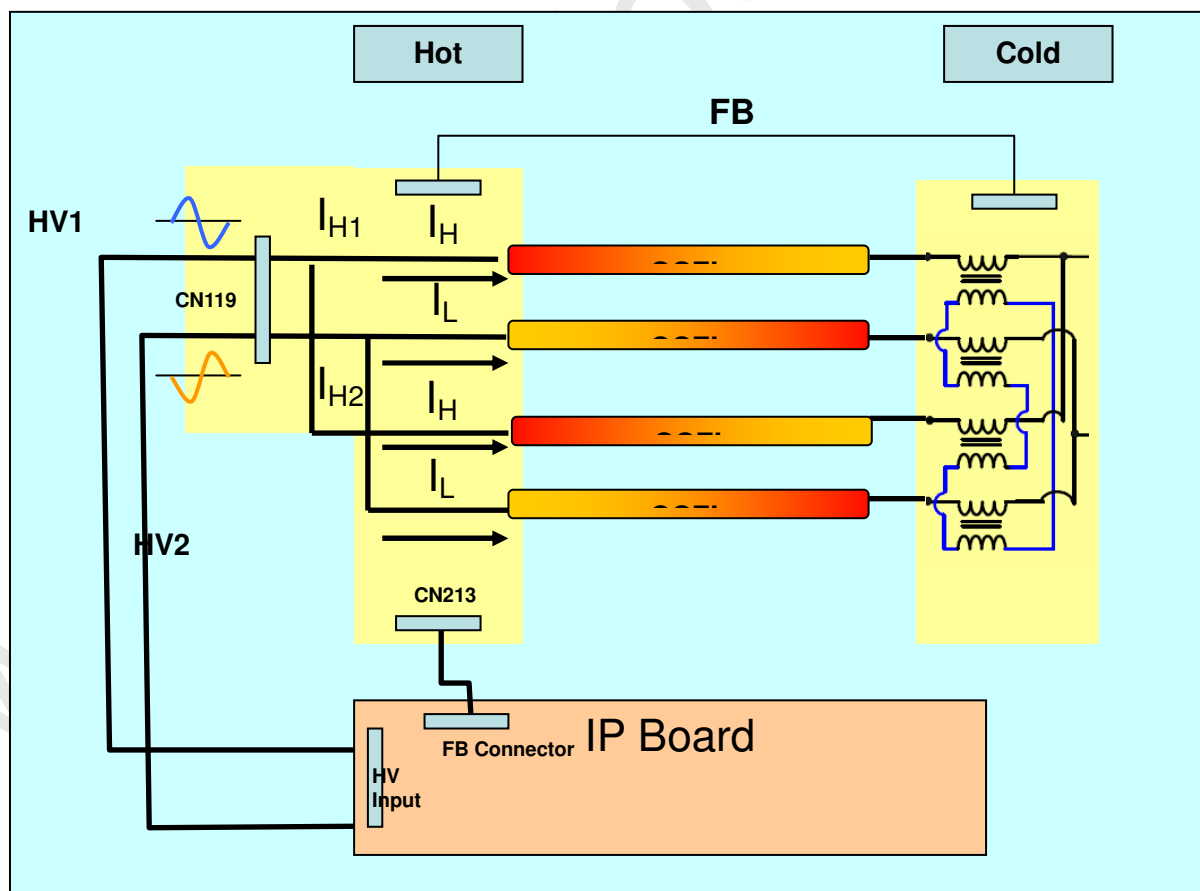





## 4. INPUT TERMINAL PIN ASSIGNMENT

### 4-1 TFT-LCD Module

- LCD connector (CN3): JAE FI-E30S-HF

Mating connector:

No	Signal
1	NC
2	NC
3	NC
4	GND
5	Rx0-
6	Rx0+
7	GND
8	Rx1-
9	Rx1+
10	GND
11	Rx2-
12	Rx2+
13	GND
14	RxCLK-
15	RxCLK+
16	GND
17	Rx3-
18	Rx3+
19	GND
20	NC
21	LVDS Option (3)
22	N.C
23	GND
24	GND
25	GND
26	Vcc (+5V)
27	Vcc (+5V)
28	Vcc(+5V)
29	Vcc (+5V)
30	Vcc (+5V)

**Note:**

1. All GND (ground) pins should be connected together and should also be connected to the LCD's metal frame. All Vcc (power input) pins should be connected together.
2. NC Only – Pull High or Low is not allowed



## 4-2 Balance board UNITS

### 4-2-1 Hot Board unit

	Connector	PIN	Symbol	Description	I/O
High Voltage connector	CN119	1	HV1	+High Voltage	Input
		2	HV2	- High Voltage	Input
Feedback Connector	CN213	1	VDD	Supply Voltage	Input
		2	FB	Current feedback control	Output
		3	GND	GND	-
		4	OLP	Open Lamp Protection	Output
		5	LD	Lamp detector	Output

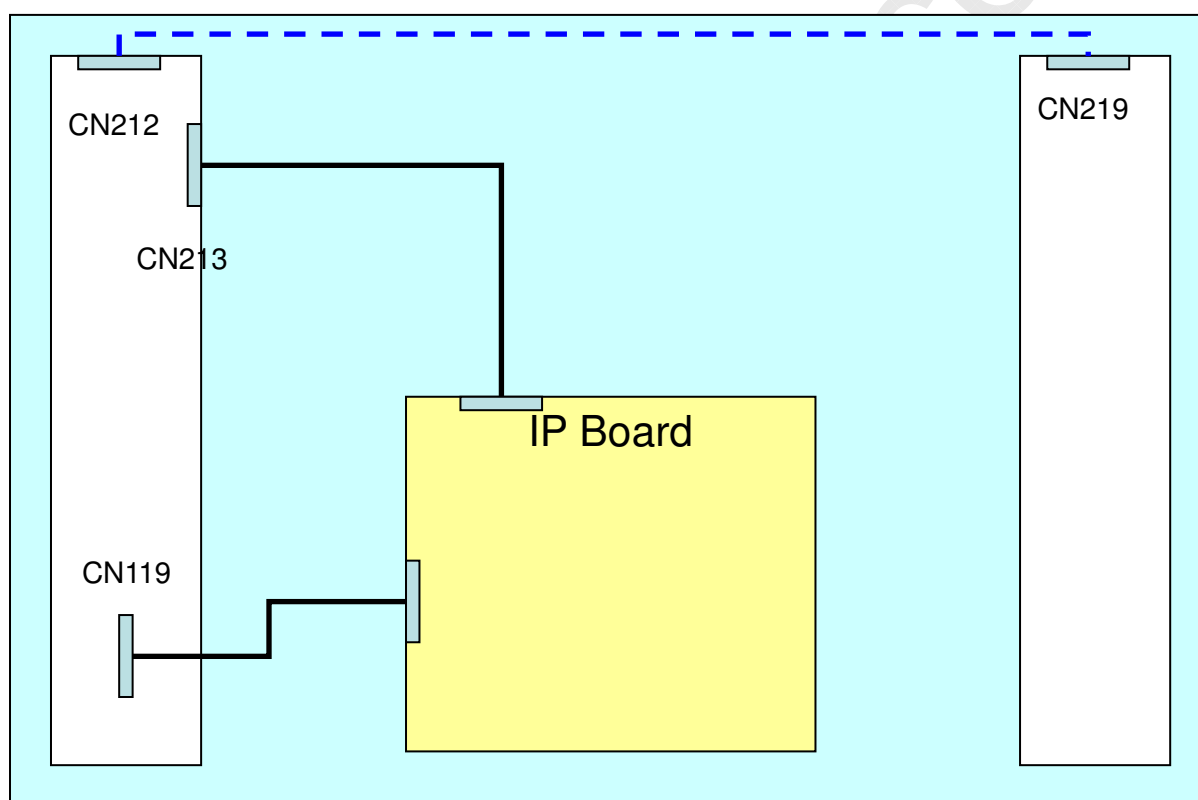

**4-2-2 Recommend operation condition****(Ta=25±2°C)**

	ITEM	symbol	Min	Typ	Max	UNIT	Note
1	Lamp Voltage	HV		1475		V	
2	Total input current	IT	150	165	180	mA	Hot side
3	Output current	IL	7.5	8.25	9	mA	Hot current
4	Inverter Frequency	FOP	50	60	70	kHz	

www.panelook.com



### 4-2-3 Feedback Signal Specification

These operation condition is recommended for operating the balance board.

( $T_a=25\pm 2^\circ\text{C}$ )

Feedback I/O specification

No	Item	SYMBOL	MIN	TYP	MAX	UNIT	Note
1	Lamp detected	LD	0	-	0.8	V	At abnormal condition
			10	-	12	V	At normal condition
2	Open lamp protected	OLP	0		0.8	V	At normal condition
			11	12	13	V	At OLP status
3	Current feedback signal	FB	1.0	1.0	1.54	V	At $I_T=120\text{mA}$
4	Supply voltage	VDD	6	12	15	V	At recommended Load condition
5	Input current	Ic	-	20	-	mA	-



### 4-3 LVDS DATA FORMAT

#### LVDS Option = L (GND)

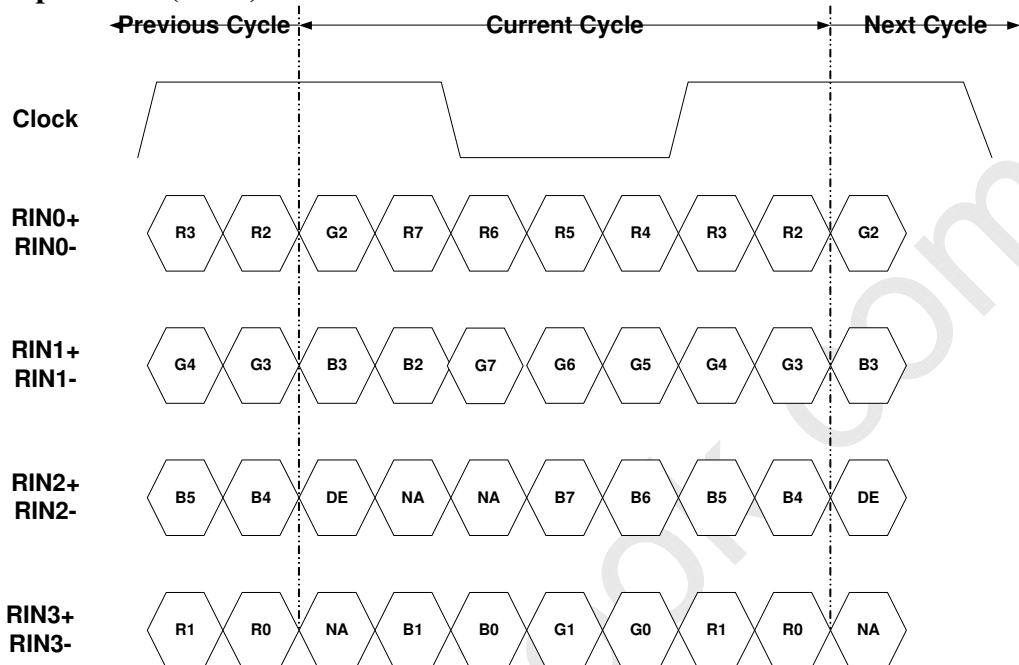

#### LVDS Option = H (3.3V) or N.C. → NS Format

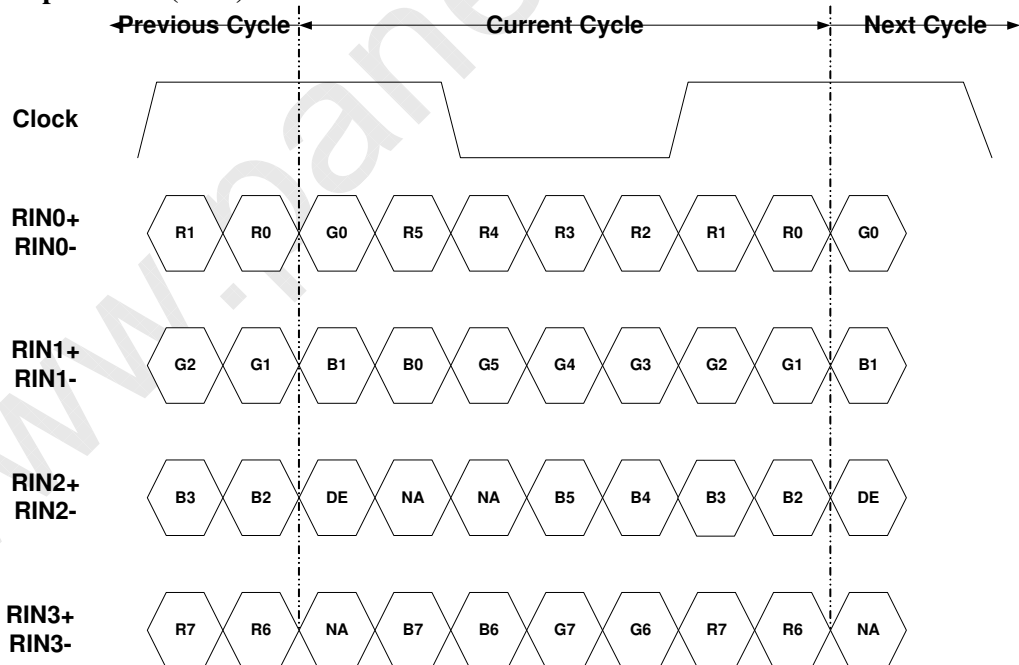



#### 4-4 COLOR INPUT DATA ASSIGNMENT

The brightness of each primary color (red, green and blue) is based on the 8 bit gray scale data input for the color; the higher the binary input, the brighter the color. The table below provides a reference for color versus data input.

#### COLOR DATA REFERENCE

Color		Input Color Data																							
		RED								GREEN								BLUE							
		MSB				LSB				MSB				LSB				MSB				LSB			
		R7	R6	R5	R4	R3	R2	R1	R0	G7	G6	G5	G4	G3	G2	G1	G0	B7	B6	B5	B4	B3	B2	B1	B0
Basic Color	Black	0	0	0	0	0	0	0	0	0	0	0	0	0	0	0	0	0	0	0	0	0	0	0	0
	Red(255)	1	1	1	1	1	1	1	1	0	0	0	0	0	0	0	0	0	0	0	0	0	0	0	0
	Green(255)	0	0	0	0	0	0	0	0	1	1	1	1	1	1	1	1	0	0	0	0	0	0	0	0
	Blue(255)	0	0	0	0	0	0	0	0	0	0	0	0	0	0	0	0	1	1	1	1	1	1	1	1
	Cyan	0	0	0	0	0	0	0	0	1	1	1	1	1	1	1	1	1	1	1	1	1	1	1	1
	Magenta	1	1	1	1	1	1	1	1	0	0	0	0	0	0	0	0	1	1	1	1	1	1	1	1
	Yellow	1	1	1	1	1	1	1	1	1	1	1	1	1	1	1	1	0	0	0	0	0	0	0	0
	White	1	1	1	1	1	1	1	1	1	1	1	1	1	1	1	1	1	1	1	1	1	1	1	1
RED	RED(000)	0	0	0	0	0	0	0	0	0	0	0	0	0	0	0	0	0	0	0	0	0	0	0	0
	RED(001)	0	0	0	0	0	0	0	1	0	0	0	0	0	0	0	0	0	0	0	0	0	0	0	0
	----																								
	RED(254)	1	1	1	1	1	1	1	0	0	0	0	0	0	0	0	0	0	0	0	0	0	0	0	0
	RED(255)	1	1	1	1	1	1	1	1	0	0	0	0	0	0	0	0	0	0	0	0	0	0	0	0
GREEN	GREEN(000)	0	0	0	0	0	0	0	0	0	0	0	0	0	0	0	0	0	0	0	0	0	0	0	0
	GREEN(001)	0	0	0	0	0	0	0	0	0	0	0	0	0	0	0	1	0	0	0	0	0	0	0	0
	----																								
	GREEN(254)	0	0	0	0	0	0	0	0	1	1	1	1	1	1	1	0	0	0	0	0	0	0	0	0
	GREEN(255)	0	0	0	0	0	0	0	0	1	1	1	1	1	1	1	1	0	0	0	0	0	0	0	0
BLUE	BLUE(000)	0	0	0	0	0	0	0	0	0	0	0	0	0	0	0	0	0	0	0	0	0	0	0	0
	BLUE(001)	0	0	0	0	0	0	0	0	0	0	0	0	0	0	0	0	0	0	0	0	0	0	0	1
	-----																								
	BLUE(254)	0	0	0	0	0	0	0	0	0	0	0	0	0	0	0	0	1	1	1	1	1	1	1	0
	BLUE(255)	0	0	0	0	0	0	0	0	0	0	0	0	0	0	0	0	1	1	1	1	1	1	1	1



## 5. Interface Timing

### 5-1 INPUT SIGNAL TIMING SPECIFICATIONS:

This is the signal timing required at the input of the User connector. All of the interface signal timing should be satisfied with the following specifications for its proper operation.

#### Timing Table (DE only Mode)

A. Frame Rate = 60 Hz

Signal	Item	Symbol	MIN	TYP	MAX	Unit
Vertical Section	Period	Tv	789	806	1000	Th
	Active	Tdisp(v)		768		Th
	Blanking	Tblk(v)	21	38	232	Th
Horizontal Section	Period	Th	1414	1560	1722	Tclk
	Active	Tdisp(h)		1366		Tclk
	Blanking	Tblk(h)	48	194	356	Tclk
Vertical Frequency	Frequency	Freq	47	60	63	Hz
Horizontal Frequency	Frequency	Freq	43	48	50	KHz
Clock	Frequency	FCLK	65	76	85	MHz

1.) Display position is specific by the rise of DE signal only.

Horizontal display position is specified by the falling edge of 1<sup>st</sup> DCLK right after the rise of ENAB, is displayed on the left edge of the screen.

Vertical display position is specified by the rise of DE after a "Low" level period equivalent to eight times of horizontal period. The 1<sup>st</sup> data corresponding to one horizontal line after the rise the of ENAB is displayed at the top line of screen.

3.) If a period of DEB "High" is less than 1366 DCLK or less than 768 lines, the rest of the screen displays black.

4.) The display position does not fit to the screen if a period of DE "High" and the effective data period do not synchronize with each other.



Signal Timing Waveforms

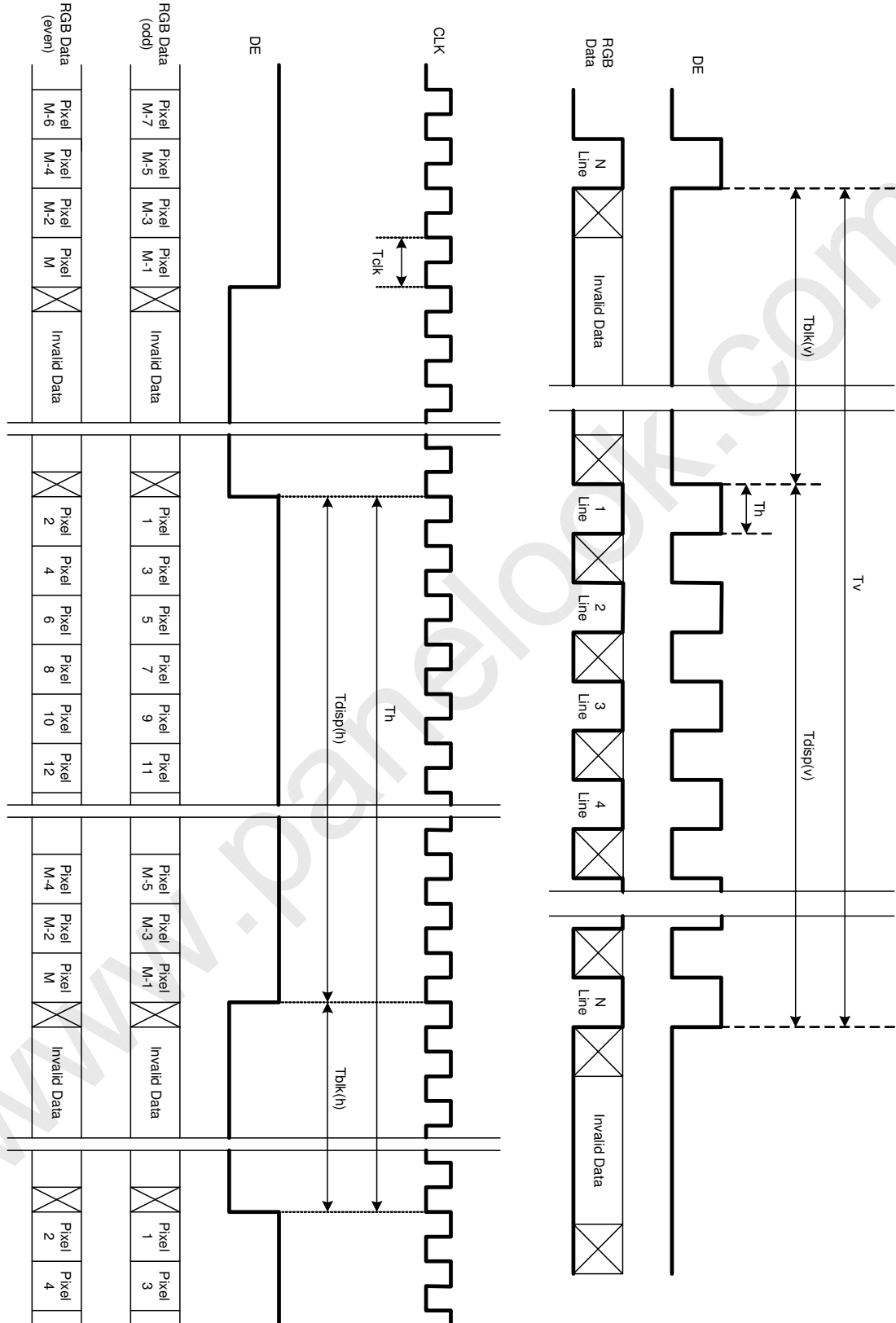





## 5-2 Power Sequence of LCD Module (ON/OFF)

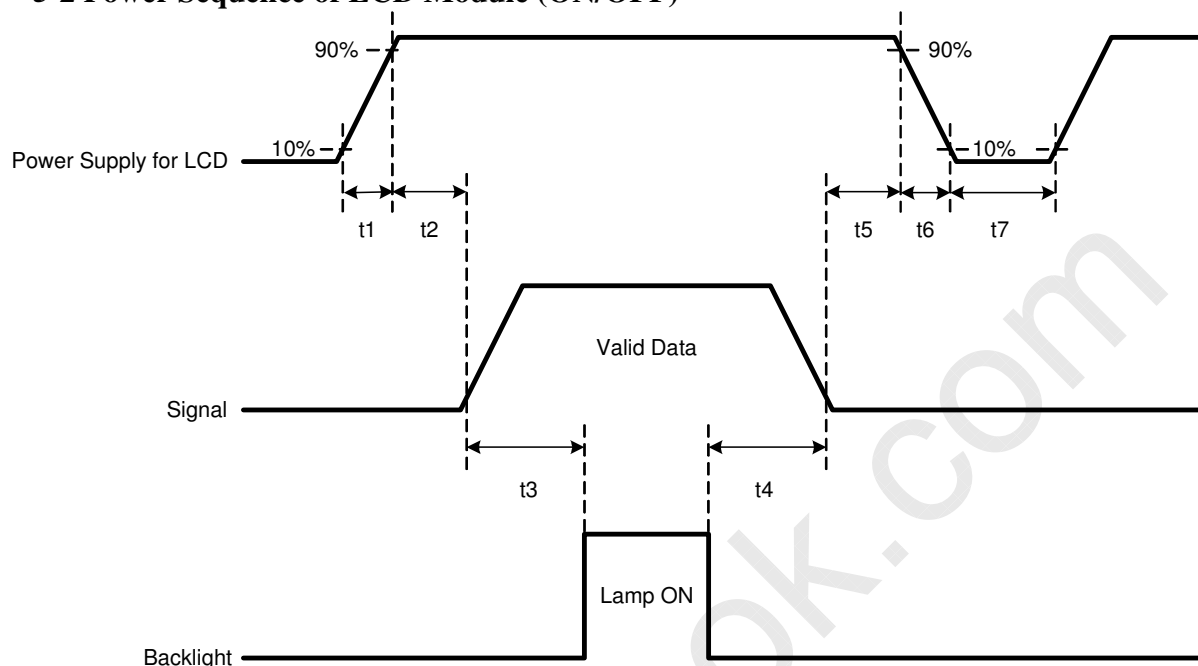

Parameter	Values			Units Min.
	Min.	Typ.	Max.	
T1	470	-	1000	<b>us</b>
T2	20	-	35	<b>ms</b>
T3	500	-	-	<b>ms</b>
T4	200	-	-	<b>ms</b>
T5	5	-	-	<b>ms</b>
T6	-	-	30	<b>ms</b>
T7	1	-	-	<b>s</b>

**Note:** User should follow the power on/off sequence and the rising/falling time to avoid miss operation of the panel.



### 5-3 Power Sequence of Inverter

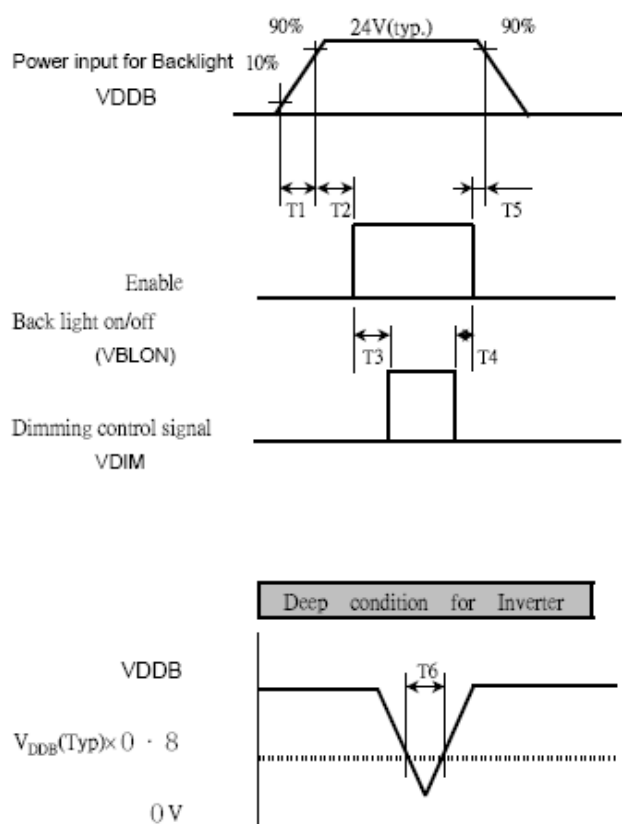

Parameter	Values			Units
	Min.	Typ.	Max.	
T1	20	-	-	us
T2	500	-	-	ms
T3	250	-	-	ms
T4	0	-	-	ms
T5	1	-	-	ms
T6	-	-	10	ms



## 6. Optical Specification

### 6-1 Warm-up procedure & testing methods & testing condition

**Warm-up procedure:** Stable for 45 minutes in dark environment at 25°C.

**Measurement tools:** BM7 or equivalent

**Testing method:** Specified distance is 50cm from LCD surface at a viewing angle of  $\varphi$  and  $\theta$  is 0°.  
(Measurement Equipment is shown in Fig.1)

**Testing Condition:**

Parameter	Value	Parameter	Value
VDDDB	24V	Frequency (f <sub>v</sub> )	60Hz
IDDB	5A	Temperature	Ta=25±2°C

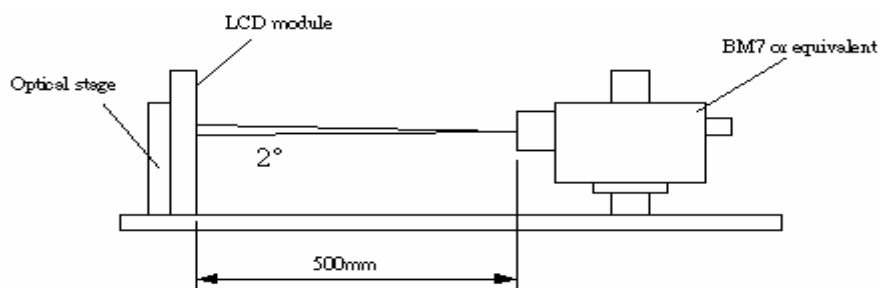

FIG.1 Measurement equipment

### 6-2 Optical Specification

(Ta=25±2°C)

Parameter	Symbol	Condition	Value			Units	Notes	
			Min.	Typ.	Max.			
Contrast Ratio	CR	$\varphi = 0^\circ, \theta = 0^\circ$ Viewing Normal angle	1200	1500			<b>1</b>	
Surface Luminance, white	LWH		380	430		cd/m <sup>2</sup>	<b>2</b>	
Luminance Variation	$\delta_{\text{WHITE}}$   9 pts				1.3	cd/m <sup>2</sup>	<b>3</b>	
Response Time	Rise Time		T <sub>R</sub>		15		ms	<b>4</b>
	Decay Time		T <sub>D</sub>		8		ms	
	Gray to Gray		T <sub>γ</sub>		(8)		ms	
Color Coordinates (CIE 1931)	RED		R <sub>X</sub>	Typ -0.03	0.640	Typ +0.03		
			R <sub>Y</sub>		0.330			
	GREEN		G <sub>X</sub>		0.29			
			G <sub>Y</sub>		0.600			
	BLUE	B <sub>X</sub>	0.150					
		B <sub>Y</sub>	0.060					
WHITE	W <sub>X</sub>	0.280						
	W <sub>Y</sub>	0.290						
Viewing Angle	x axis, right	$\theta_r$   ( $\varphi = 0^\circ$ )	CR≥20	88		Degree	<b>5</b>	
	x axis, left	$\theta_l$   ( $\varphi = 180^\circ$ )		88				
	y axis, up	$\theta_u$   ( $\varphi = 90^\circ$ )		88				
	y axis, down	$\theta_d$   ( $\varphi = 0^\circ$ )		88				



### Note:

1. Contrast ratio will be measured in the center of panel (point 5 in Figure 2), Contrast Ratio (CR) is defined mathematically as:

$$C/R(\text{Contrast ratio}) = \frac{\text{Lum}(L255)}{\text{Lum}(L0)}$$

Lum(L255): Luminance measured at the center point of panel when all pixels is white.

Lum(L0) : Luminance measured at the center point of panel when all pixels is black.

2. Surface luminance is defined as luminance value measured at point 5 with pre-described measurement methods and measurement condition.

3. Luminance variation,  $\delta$  WHITE, is defined as:

$$\delta_{\text{WHITE (9P)}} = \frac{\text{Maximum}(L_{\text{on1}}, L_{\text{on2}}, \dots, L_{\text{on9}})}{\text{Minimum}(L_{\text{on1}}, L_{\text{on2}}, \dots, L_{\text{on9}})} \quad \text{Position of each 9 pts for measuring is shown in FIG 2.}$$

4. Response time is the time required for the display to transition from black to white (Rise Time,  $T_{\text{R}}$ ) and from white to black (Decay Time,  $T_{\text{D}}$ ), that is shown in FIG3.

5. Detailed measurement method of viewing angle is shown in Fig4.

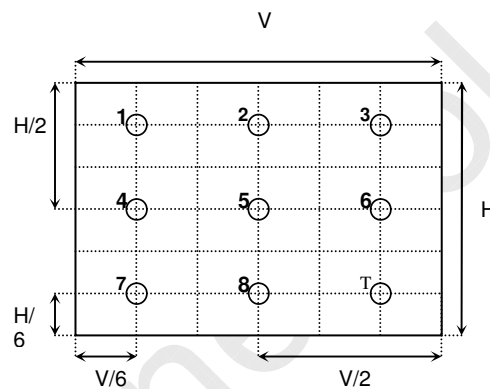

**FIG. 2 Luminance measurement positions**

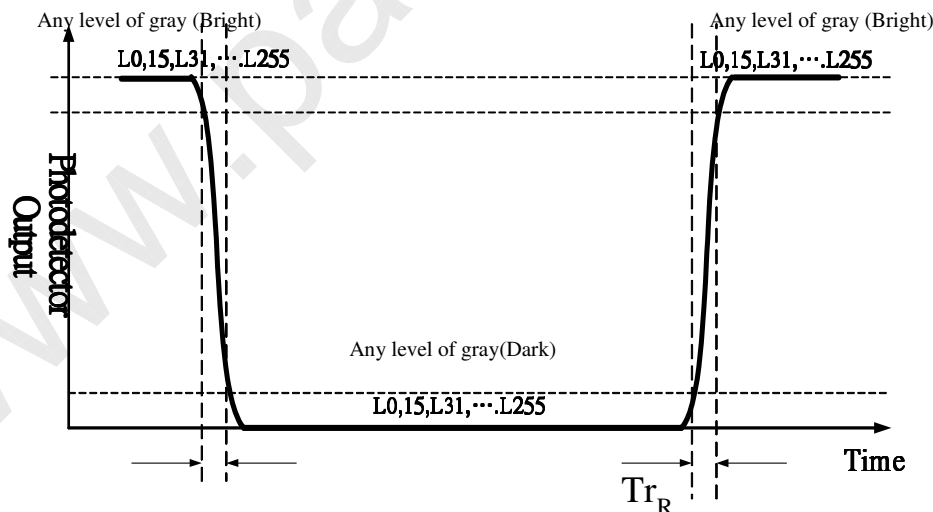

**Note:** The response time is defined as the following figure and shall be measured by switching the input signal for “any level of gray(bright)” and “any level of gray(dark)”

**FIG.3 Measurement of Response Time**

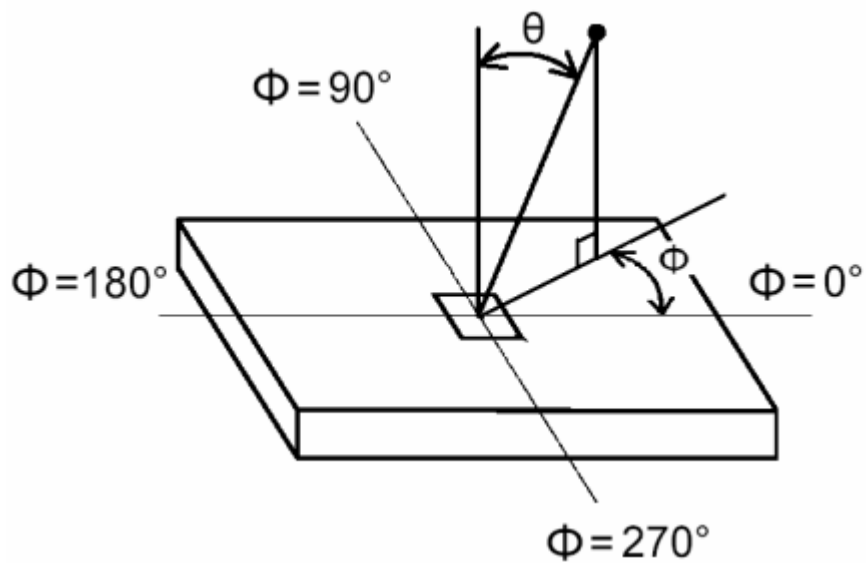

FIG.4 Measurement of viewing angle



## 7. Mechanical Characteristics

The contents provide general mechanical characteristics for the model T400XW01 V1. Detailed mechanical drawings are shown in the following pages.

Outline Dimension	Horizontal	952.0 mm
	Vertical	551.0 mm
	Depth	46.4 mm(to balance board cover) 48.4 mm (To Balance board connector)
Bezel Opening	Horizontal	891.7 mm
	Vertical	504.2 mm
Active Display Area	Horizontal	885.158mm
	Vertical	497.664 mm
Weight	11000g (Typ.)	

www.panelook.com



Mechanical Figure:

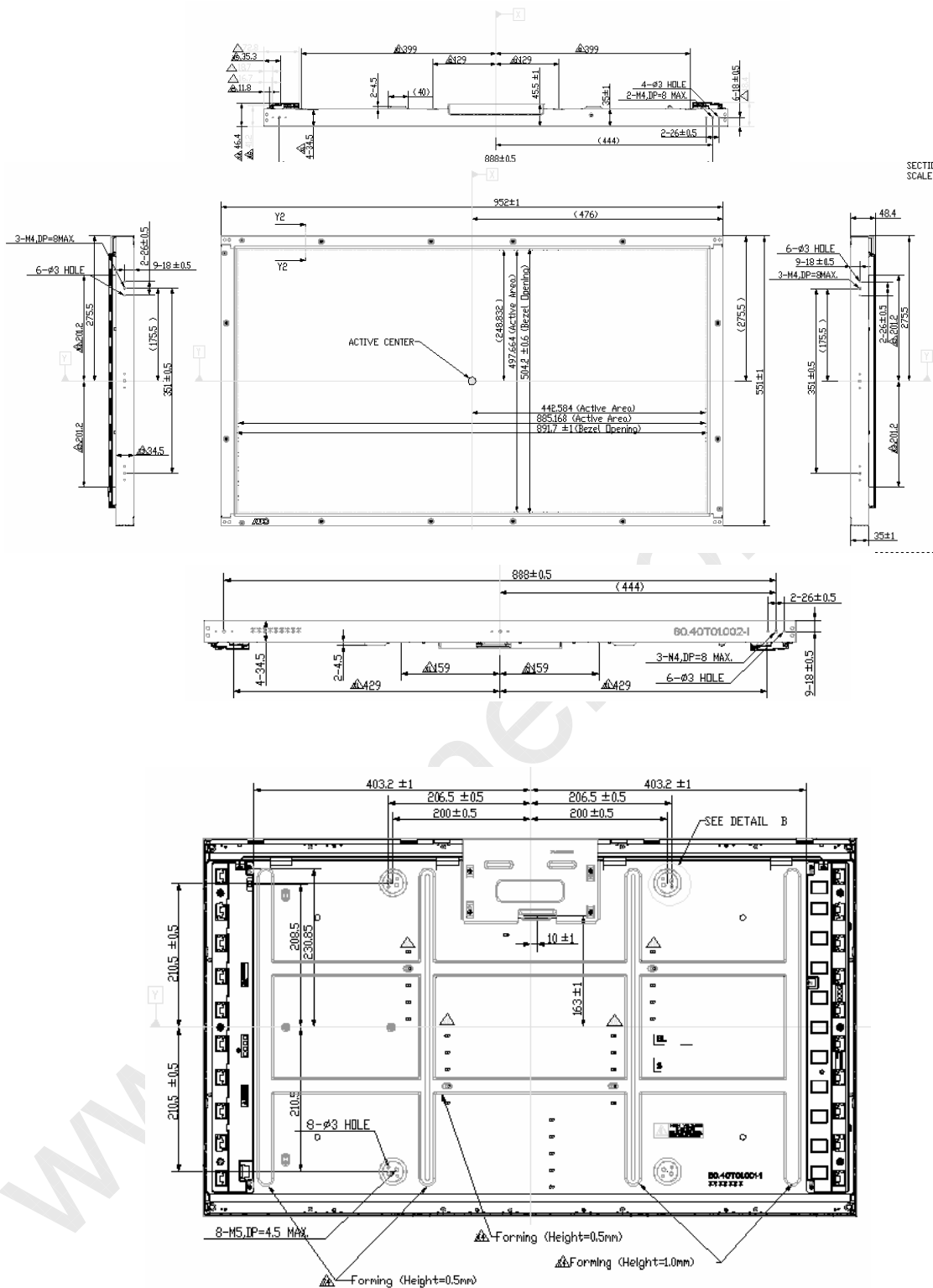



## 8. Reliability

Environment test condition:

Panel condition in RA test

Brightness : 550nits

Lamp Current (Cold end) : 5.5mA

No	Test Item	Condition
1	High temperature storage test	Ta=60°C 240h
2	Low temperature storage test	Ta= -20°C 240h
3	High temperature operation test	Ta=50°C 80%RH 240h
4	Low temperature operation test	Ta=0°C 240h
5	Vibration test (non-operating)	Wave form: random Vibration level: 1.5G RMS Bandwidth: 10-500Hz, Duration: X, Y, Z 20min One time each direction
6	Shock test (non-operating)	Shock level: 50G Waveform: half sine wave, 11ms Direction: ±X, ±Y, ±Z One time each direction
7	Vibration test (with carton)	Wave form: random Vibration level: 1.5G RMS Bandwidth: 10-500Hz, Duration: X, Y, Z 30min One time each direction
8	Drop test (with carton)	Height: 53.3cm 1 corner, 3 edges, 6 surfaces (ASTMD4169-I)





## 9. International Standard

### 9-1 Safety

- (1) UL1950 Third Edition, Underwriters Laboratories, Inc. Jan. 28, 1995  
Standard for Safety of Information Technology Equipment Including electrical Business Equipment.
- (2) CAN/CSA C22.2 No. 950-95/60950 Third Edition, Canadian Standards Association,  
Standard for Safety of Information Technology Equipment Including Electrical Business Equipment.
- (3) EN60950: 1992+A2: 1993+A2: 1993+C3: 1995+A4: 1997+A11: 1997  
IEC 950: 1991+A1: 1992+A2: 1993+C3: 1995+A4:1996  
European Committee for Electrotechnical Standardization (CENELEC)  
EUROPEAN STANDARD for Safety of Information Technology Equipment Including  
Electrical Business Equipment.

### 9-2 EMC

- a) ANSI C63.4 “Methods of Measurement of Radio-Noise Emissions from Low-Voltage Electrical and Electrical Equipment in the Range of 9kHz to 40GHz. “American National standards Institute(ANSI), 1992
- b) C.I.S.P.R “Limits and Methods of Measurement of Radio Interface Characteristics of Information Technology Equipment.” International Special committee on Radio Interference.
- c) EN 55022 “Limits and Methods of Measurement of Radio Interface Characteristics of Information Technology Equipment.” European Committee for Electrotechnical Standardization. (CENELEC), 1998



## 10. Packing

### 10-1 DEFINITION OF LABEL:

#### A. Panel Label:



#### Green mark description

For Pb Free Product, AUO will add  for identification.

For RoHs compatible products, AUO will add  for identification.

**Note:** The green Mark will be present only when the green documents have been ready by AUO internal green team. (The definition of green design follows the AUO green design checklist.)

#### B. Carton Label:





### 10-2 PACKING METHODS:

3pcs Modules

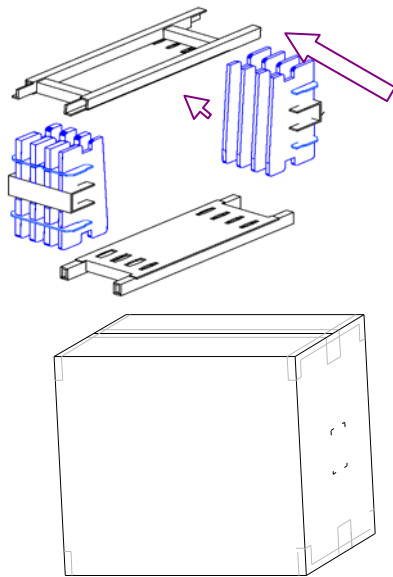

www.panelook.com



## 11. PRECAUTIONS

Please pay attention to the followings when you use this TFT LCD module.

### 11-1 MOUNTING PRECAUTIONS

- (1) You must mount a module using holes arranged in four corners or four sides.
- (2) You should consider the mounting structure so that uneven force (ex. Twisted stress) is not applied to module. And the case on which a module is mounted should have sufficient strength so that external force is not transmitted directly to the module.
- (3) Please attach the surface transparent protective plate to the surface in order to protect the polarizer. Transparent protective plate should have sufficient strength in order to resist external force.
- (4) You should adopt radiation structure to satisfy the temperature specification.
- (5) Acetic acid type and chlorine type materials for the cover case are not desirable because the former generates corrosive gas of attacking the polarizer at high temperature and the latter causes circuit break by electro-chemical reaction.
- (6) Do not touch, push or rub the exposed polarizer with glass, tweezers or anything harder than HB pencil lead. And please do not rub with dust clothes with chemical treatment. Do not touch the surface of polarizer for bare hand or greasy cloth. (Some cosmetics are detrimental to the polarizer.)
- (7) When the surface becomes dusty, please wipe gently with absorbent cotton or other soft materials like chamois soaks with petroleum benzene. Normal-hexane is recommended for cleaning the adhesives used to attach front/ rear polarizer. Do not use acetone, toluene and alcohol because they cause chemical damage to the polarizer.
- (8) Wipe off saliva or water drops as soon as possible. Their long time contact with polarizer causes deformations and color fading.
- (9) Do not open the case because inside circuits do not have sufficient strength.

### 11-2 OPERATING PRECAUTIONS

- (1) The spike noise causes the mis-operation of circuits. It should be lower than following voltage:  $V=\pm 200\text{mV}$  (Over and under shoot voltage)
- (2) Response time depends on the temperature. (In lower temperature, it becomes longer.)
- (3) Brightness of CCFL depends on the temperature. (In lower temperature, it becomes lower.) And in lower temperature, response time (required time that brightness is stable after turned on) becomes longer.
- (4) Be careful for condensation at sudden temperature change. Condensation makes damage to polarizer or electrical contacted parts. And after fading condensation, smear or spot will occur.
- (5) When fixed patterns are displayed for a long time, remnant image is likely to occur.
- (6) Module has high frequency circuits. Sufficient suppression to the electromagnetic interference shall be done by system manufacturers. Grounding and shielding methods may be important to minimize the interface.



### 11-3 ELECTROSTATIC DISCHARGE CONTROL

Since a module is composed of electronic circuits, it is not strong to electrostatic discharge. Make certain that treatment persons are connected to ground through wristband etc. And don't touch interface pin directly.

### 11-4 PRECAUTIONS FOR STRONG LIGHT EXPOSURE

Strong light exposure causes degradation of polarizer and color filter.

### 11-5 STORAGE

When storing modules as spares for a long time, the following precautions are necessary.

- (1) Store them in a dark place. Do not expose the module to sunlight or fluorescent light. Keep the temperature between 5°C and 35°C at normal humidity.
- (2) The polarizer surface should not come in contact with any other object. It is recommended that they be stored in the container in which they were shipped.

### 11-6 HANDLING PRECAUTIONS FOR PROTECTION FILM

- (1) The protection film is attached to the bezel with a small masking tape. When the protection film is peeled off, static electricity is generated between the film and polarizer. This should be peeled off slowly and carefully by people who are electrically grounded and with well ion-blown equipment or in such a condition, etc.
- (2) When the module with protection film attached is stored for a long time, sometimes there remains a very small amount of glue still on the bezel after the protection film is peeled off.
- (3) You can remove the glue easily. When the glue remains on the bezel or its vestige is recognized, please wipe them off with absorbent cotton waste or other soft material like chamois soaked with normal-hexane.