

Model Name: T420HVN04.3

Issue Date : 2012/09/19

(*)Preliminary Specifications

()Final Specifications

Customer Signature	Date	AUO	Date
Approved By		Approval By PM Director Jacky Su	
Note		Reviewed By RD Director Eugene CC Chen	
		Reviewed By Project Leader Ebola Lee	
		Prepared By PM Jun Chang	

CONTENTS

CONTENTS	2
RECORD OF REVISION	3
1. GENERAL DESCRIPTION	4
2. ABSOLUTE MAXIMUM RATINGS	5
3. ELECTRICAL SPECIFICATION	6
3.1 ELECTRICAL CHARACTERISTICS	6
3.1.1 DC CHARACTERISTICS	6
3.1.2 AC CHARACTERISTICS	7
3.1.3 DRIVER CHARACTERISTICS	7
3.2 INTERFACE CONNECTIONS	11
3.2.1 T-CON BOARD PIN MAP	11
3.2.2 LVDS OPTION	13
3.3 SIGNAL TIMING SPECIFICATION	14
3.4 SIGNAL TIMING WAVEFORMS	15
3.5 COLOR INPUT DATA REFERENCE	16
3.6 POWER SEQUENCE FOR LCD	17
3.7 VCOM ADJUST SOP	18
3.7.1 VCOM I2C TUNING STEP	18
3.7.2 FLICKER PATTERN	18
3.7.3 WP (WRITE PROTECT) DISABLE	18
3.7.4 ADJUST SOP	18
3.7.5 INTERVAL OF STEP TO STEP	19
4. OPTICAL SPECIFICATION	20
5. MECHANICAL CHARACTERISTICS	24
6. PACKING	25
7. PRECAUTIONS	27
7.1 MOUNTING PRECAUTIONS	27
7.2 OPERATING PRECAUTIONS	27
7.3 ELECTROSTATIC DISCHARGE CONTROL	27
7.4 PRECAUTIONS FOR STRONG LIGHT EXPOSURE	27
7.5 STORAGE	28
7.6 HANDLING PRECAUTIONS FOR PROTECTION FILM OF POLARIZER	28



RECORD OF REVISION

Version	Date	Page	Description
0.1	2012/09/19		First release

1. GENERAL DESCRIPTION

This specification applies to the 42.02 inch Color TFT-LCD SKD model T420HVN04.3. This LCD Open Cell Unit has a TFT active matrix type liquid crystal panel 1,920x1,080 pixels, and diagonal size of 42.02 inch. This Open Cell Unit supports 1,920x1,080 mode. Each pixel is divided into Red, Green and Blue sub-pixels or dots which are arranged in vertical stripes. Gray scale or the brightness of the sub-pixel color is determined with a 10-bit gray scale signal for each dot.

* General Information

Items	Specification	Unit	Note
Active Screen Size	42.00	inch	
Display Area	930.24(H) x 523.26(V)	mm	
Outline Dimension	946.24(H) x 540.06 (V) x 1.34(D)	mm	D: cell thickness
Driver Element	a-Si TFT active matrix		
Bezel Opening	939 (H) x 531 (V)	mm	Recommend
Display Colors	10 bit, 1073M	Colors	
Number of Pixels	1,920x1,080	Pixel	
Pixel Pitch	0.4845 (H) x 0.4845(W)	mm	
Pixel Arrangement	RGB vertical stripe		
Display Operation Mode	Normally Black		
Surface Treatment	Anti-Glare, 3H		Haze=2%
Weight	1200	g	
Rotate Function	Unachievable		Note 1
Display Orientation	Signal input with "ABC"		Note 2

Note 1: Rotate Function refers to LCD display could be able to rotate.

Note 2: LCD display as below illustrated when signal input with "ABC".

Rear side

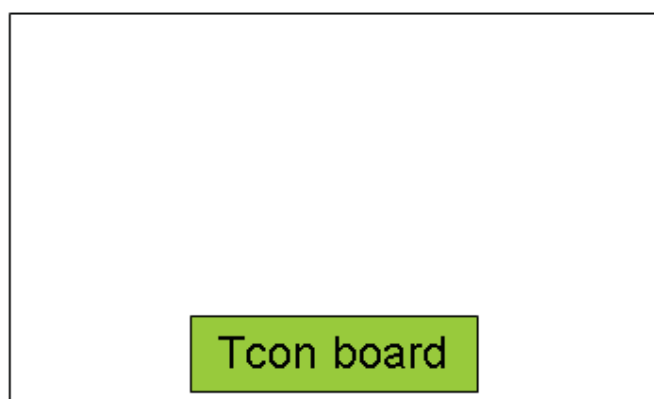

Front side

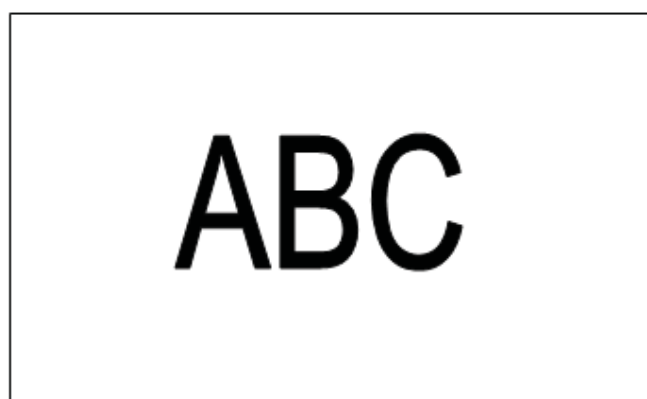

2. ABSOLUTE MAXIMUM RATINGS

The followings are maximum values which, if exceeded, may cause faulty operation or damage to the unit

Item	Symbol	Min	Max	Unit	Conditions
Logic/LCD Drive Voltage	V_{DD}	-0.3	14	[Volt] _{DC}	Note 1
Input Voltage of Signal	V_{in}	-0.3	4	[Volt] _{DC}	Note 1
Operating Temperature	TOP	0	+50	[°C]	Note 2
Operating Humidity	HOP	10	90	[%RH]	Note 2
Storage Temperature	TST	-20	+60	[°C]	Note 2
Storage Humidity	HST	10	90	[%RH]	Note 2
Panel Surface Temperature	PST		65	[°C]	Note 3

Note 1: Duration:50 msec.

Note 2 : Maximum Wet-Bulb should be 39□ and No condensation.

The relative humidity must not exceed 90% non-condensing at temperatures of 40□ or less. At temperatures greater than 40□, the wet bulb temperature must not exceed 39□.

Note 3: Surface temperature is measured at 50°C Dry condition

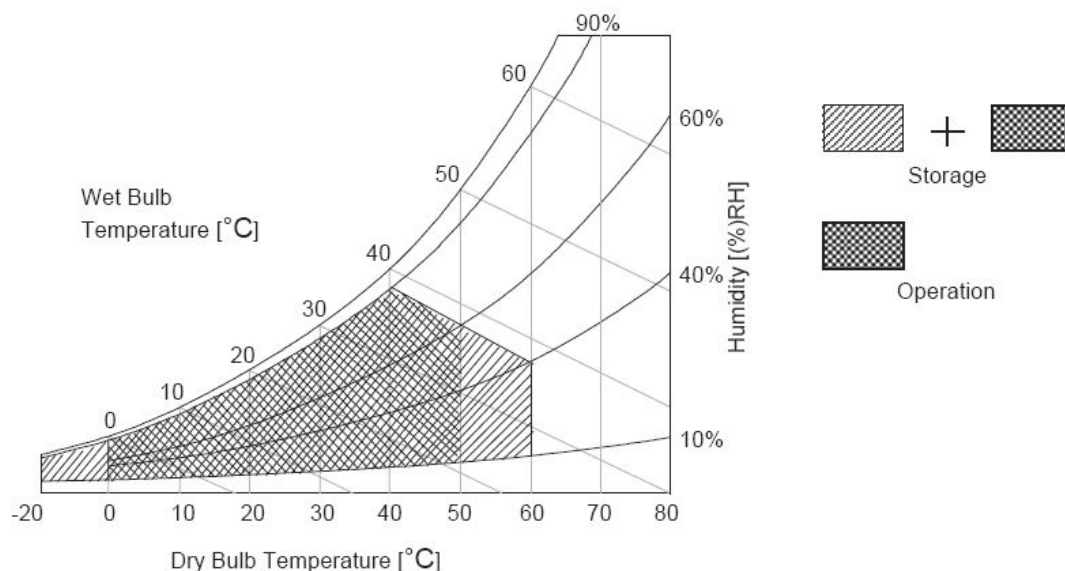

3. ELECTRICAL SPECIFICATION

The T420HVN04.3 Open Cell Unit requires power input which is employed to power the LCD electronics and to drive the TFT array and liquid crystal.

3.1 ELECTRICAL CHARACTERISTICS

3.1.1 DC CHARACTERISTICS

Parameter		Symbol	Value			Unit	Note
			Min.	Typ.	Max		
LCD							
Power Supply Input Voltage		V_{DD}	10.8	12	13.2	V_{DC}	
Power Supply Input Current		I_{DD}	--	0.89	1.07	A	1
Power Consumption		P_C	--	10.68	12.84	Watt	1
Inrush Current		I_{RUSH}	--	--	4	A	2
Permissible Ripple of Power Supply Input Voltage		V_{RP}	--	--	$V_{DD} * 5\%$	mV_{pk-pk}	3
LVDS Interface	Input Differential Voltage	$ V_{ID} $	200	400	600	mV_{DC}	4
	Differential Input High Threshold Voltage	V_{TH}	+100	--	+300	mV_{DC}	4
	Differential Input Low Threshold Voltage	V_{TL}	-300	--	-100	mV_{DC}	4
	Input Common Mode Voltage	V_{ICM}	1.1	1.25	1.4	V_{DC}	4
CMOS Interface	Input High Threshold Voltage	V_{IH} (High)	2.7	--	3.3	V_{DC}	5
	Input Low Threshold Voltage	V_{IL} (Low)	0	--	0.6	V_{DC}	5

3.1.2 AC CHARACTERISTICS

Parameter		Symbol	Value			Unit	Note
			Min.	Typ.	Max		
LVDS Interface	Input Channel Pair Skew Margin (only for TCON: 12403U1, 12405)	$t_{\text{SKEW (CP)}}$	-500	--	+500	ps	6
	Receiver Clock : Spread Spectrum Modulation range	Fclk_ss	Fclk -3%	--	Fclk +3%	MHz	7
	Receiver Clock : Spread Spectrum Modulation frequency	Fss	30	--	200	KHz	7
	Receiver Data Input Margin Fclk = 85 MHz Fclk = 65 MHz	tRMG	-0.4 -0.5	-- --	0.4 0.5	ns	8
I2C Interface	SCL clock frequency	F_{SCL}	0	--	400	KHZ	
	I2C clock high level	T_{SCHi}	0.6	--	--	us	
	I2C clock low level	T_{SCLo}	1.2	--	--	us	
	I2C data setup time	T_{SDS}	100	--	--	ns	
	I2C data hold time	T_{SDH}	0	--	900	ns	
	SDA and SCL rise time	T_{R}	--	--	1000	ns	
	SDA and SCL fall time	T_{F}	--	--	300	ns	

3.1.3 DRIVER CHARACTERISTICS

Item	Symbol	Min	Max	Unit	condition
Driver Surface Temperature	DST		100	[°C]	Note

Note : Any point on the driver surface must be less than 100°C under any conditions.

Note :**1. Test Condition:**(1) $V_{DD} = 12.0V$ (2) $F_v = 60Hz$ (3) $F_{clk} = \text{Max freq.}$

(4) Temperature = 25 °C

(5) Typ. Input current : White Pattern

Max. Input current: Heavy loading pattern defined by AUO

>> refer to "Section:3.3 Signal Timing Specification, Typical timing"

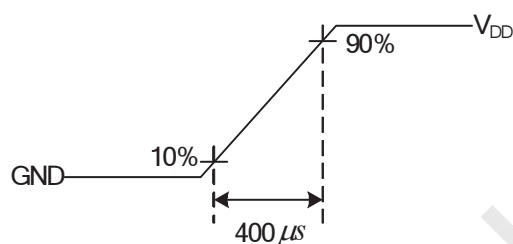
2. Measurement condition : Rising time = 400us**3. Test Condition:**(1) The measure point of V_{RP} is in LCM side after connecting the System Board and LCM.

(2) Under Max. Input current spec. condition.

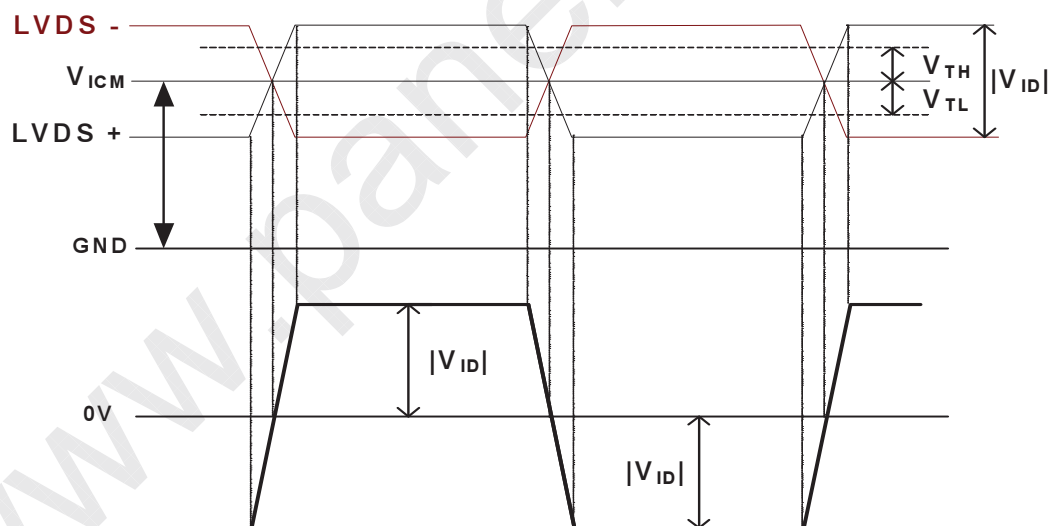
4. $V_{ICM} = 1.25V$ **5. The measure points of V_{IH} and V_{IL} are in LCM side after connecting the System Board and LCM.**

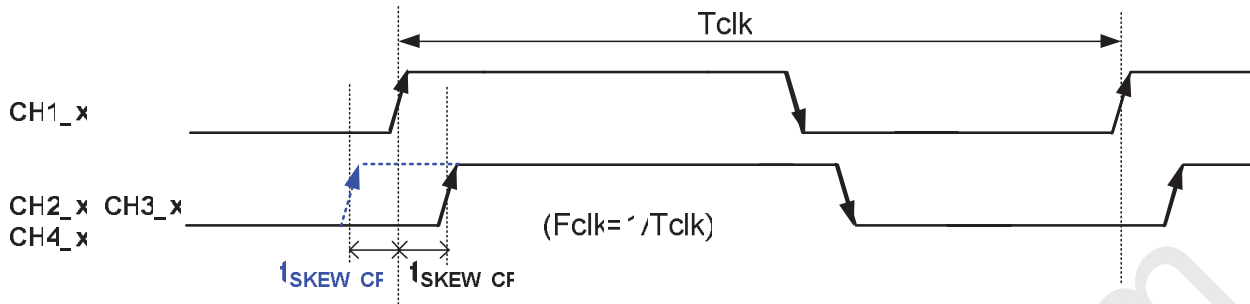
6. Input Channel Pair Skew Margin.

Note: $x = 0, 1, 2, 3, 4$

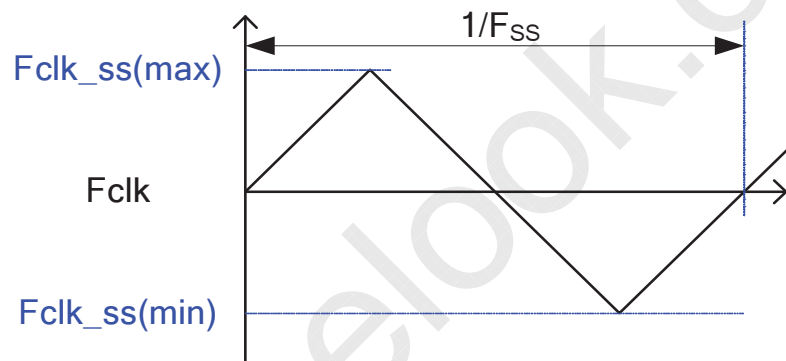
7. LVDS Receiver Clock SSCG (Spread spectrum clock generator) is defined as below figures.

8. Receiver Data Input Margin

Parameter	Symbol	Rating			Unit	Note
		Min	Type	Max		
Input Clock Frequency	Fclk	Fclk (min)	--	Fclk (max)	MHz	$T=1/Fclk$
Input Data Position0	tRIP1	$- tRMG $	0	$ tRMG $	ns	
Input Data Position1	tRIP0	$T/7- tRMG $	$T/7$	$T/7+ tRMG $	ns	
Input Data Position2	tRIP6	$2T/7- tRMG $	$2T/7$	$2T/7+ tRMG $	ns	
Input Data Position3	tRIP5	$3T/7- tRMG $	$3T/7$	$3T/7+ tRMG $	ns	
Input Data Position4	tRIP4	$4T/7- tRMG $	$4T/7$	$4T/7+ tRMG $	ns	
Input Data Position5	tRIP3	$5T/7- tRMG $	$5T/7$	$5T/7+ tRMG $	ns	
Input Data Position6	tRIP2	$6T/7- tRMG $	$6T/7$	$6T/7+ tRMG $	ns	

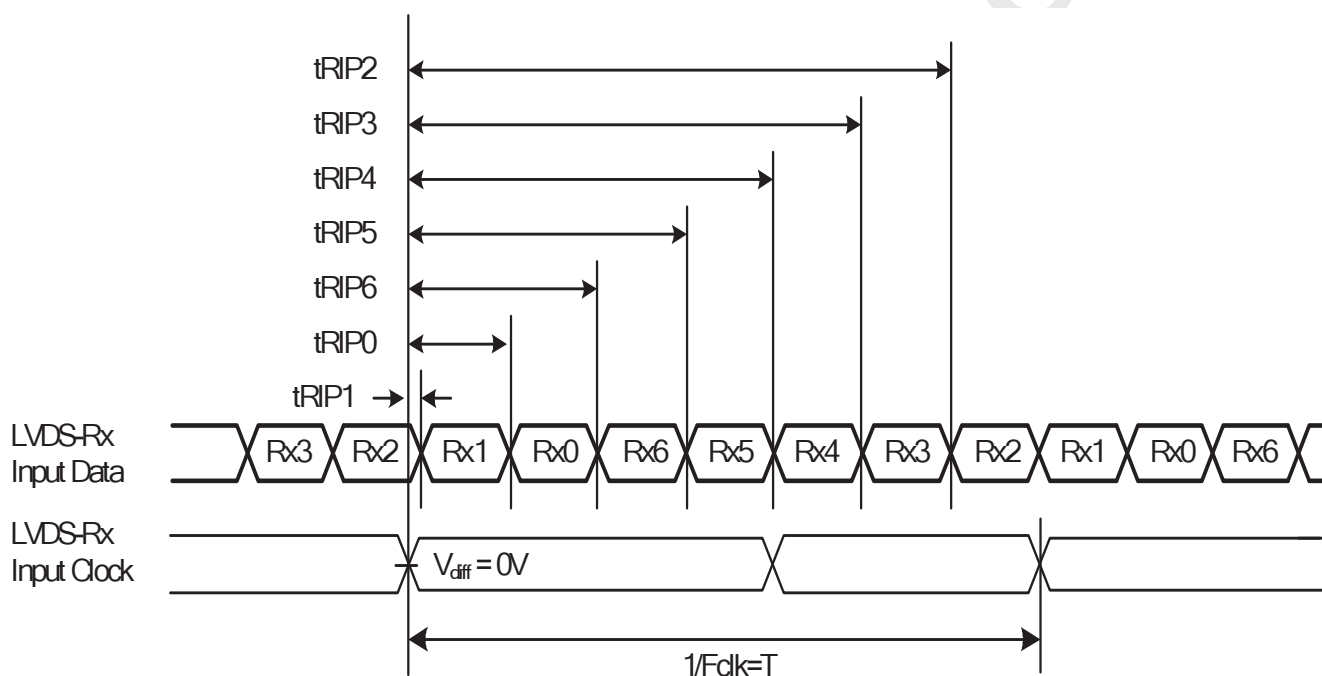

3.2 INTERFACE CONNECTIONS

3.2.1 T-CON BOARD PIN MAP

- LCD connector: FI-RE51S-HF (JAE, LVDS connector)

PIN	Symbol	Description	PIN	Symbol	Description
1	V _{DD}	Power Supply, +12V DC Regulated	26	CH2_0+	LVDS Channel 2, Signal 0+
2	V _{DD}	Power Supply, +12V DC Regulated	27	CH2_1-	LVDS Channel 2, Signal 1-
3	V _{DD}	Power Supply, +12V DC Regulated	28	CH2_1+	LVDS Channel 2, Signal 1+
4	V _{DD}	Power Supply, +12V DC Regulated	29	CH2_2-	LVDS Channel 2, Signal 2-
5	V _{DD}	Power Supply, +12V DC Regulated	30	CH2_2+	LVDS Channel 2, Signal 2+
6	N.C.	No connection (for AUO test only. Do not connect)	31	GND	Ground
7	GND	Ground	32	CH2_CLK-	LVDS Channel 2, Clock -
8	GND	Ground	33	CH2_CLK+	LVDS Channel 2, Clock +
9	GND	Ground	34	GND	Ground
10	CH1_0-	LVDS Channel 1, Signal 0-	35	CH2_3-	LVDS Channel 2, Signal 3-
11	CH1_0+	LVDS Channel 1, Signal 0+	36	CH2_3+	LVDS Channel 2, Signal 3+
12	CH1_1-	LVDS Channel 1, Signal 1-	37	CH2_4-	LVDS Channel 2, Signal 4-
13	CH1_1+	LVDS Channel 1, Signal 1+	38	CH2_4+	LVDS Channel 2, Signal 4+
14	CH1_2-	LVDS Channel 1, Signal 2-	39	GND	Ground
15	CH1_2+	LVDS Channel 1, Signal 2+	40	SCL	EEPROM Serial Clock
16	GND	Ground	41	SDA	EEPROM Serial Data
17	CH1_CLK-	LVDS Channel 1, Clock -	42	Reserve	TV Set reserved
18	CH1_CLK+	LVDS Channel 1, Clock +	43	WP	EEPROM Write Protection High(3.3V) for Writable, Low(GND) for Protection
19	GND	Ground	44	LVDS_SEL	Open/High(3.3V) for NS, Low(GND) for JEIDA
20	CH1_3-	LVDS Channel 1, Signal 3-	45	Reserve	TV Set reserved
21	CH1_3+	LVDS Channel 1, Signal 3+	46	Reserve	TV Set reserved
22	CH1_4-	LVDS Channel 1, Signal 4-	47	Reserve	TV Set reserved
23	CH1_4+	LVDS Channel 1, Signal 4+	48	Reserve	TV Set reserved
24	GND	Ground	49	Reserve	TV Set reserved
25	CH2_0-	LVDS Channel 2, Signal 0-	50	Reserve	TV Set reserved
			51	N.C.	No connection (for AUO test only. Do not connect)

Note: N.C. : please leave this pin unoccupied. It can not be connected by any signal (Low/GND/High). **Note:** Open / High(3.3V) / Low(GND) described in 3.2.1.2

Note : The description “Reserve / TV set reserved “ is used only for SONY. For other customers, “NC / No connection (for AUO test only. Do not connect) “ should be used.

Note * : Open/High(3.3V)

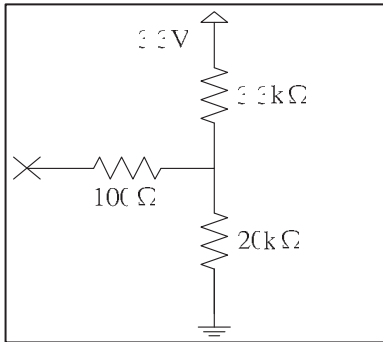

Note ** : Open/Low(GND)

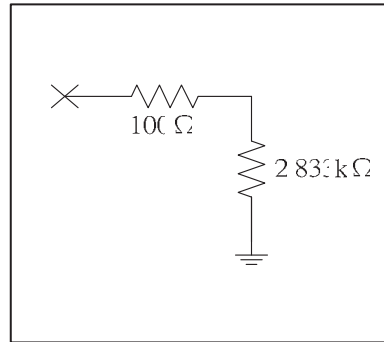

Note * : Open/Low(GND)**

3D_EN control signal can only “switch” in the middle of vertical blanking area (Tblk(V))

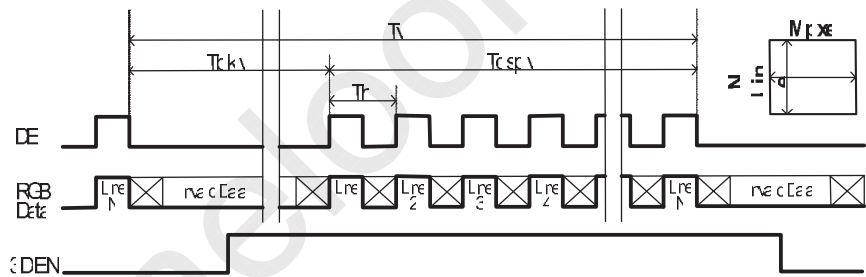
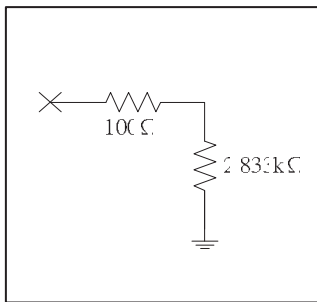

Note ** : SCL/SDA**

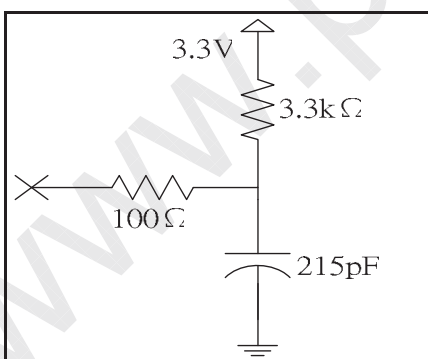

Note *** : WP**

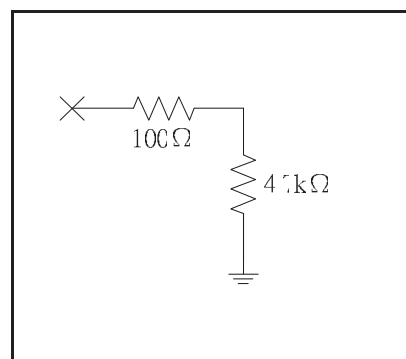

3.2.2 LVDS OPTION

■ LVDS Option = High/Open→NS

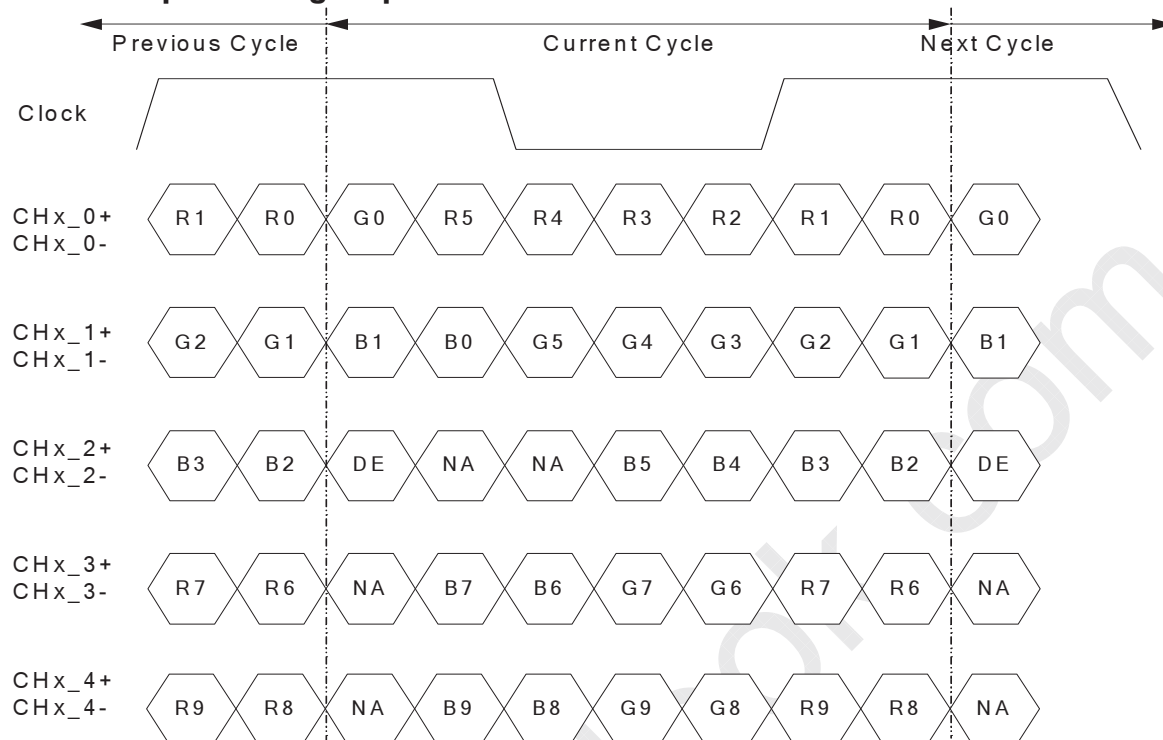

Note: x = 1, 2, 3, 4...

■ LVDS Option = Low→JEIDA

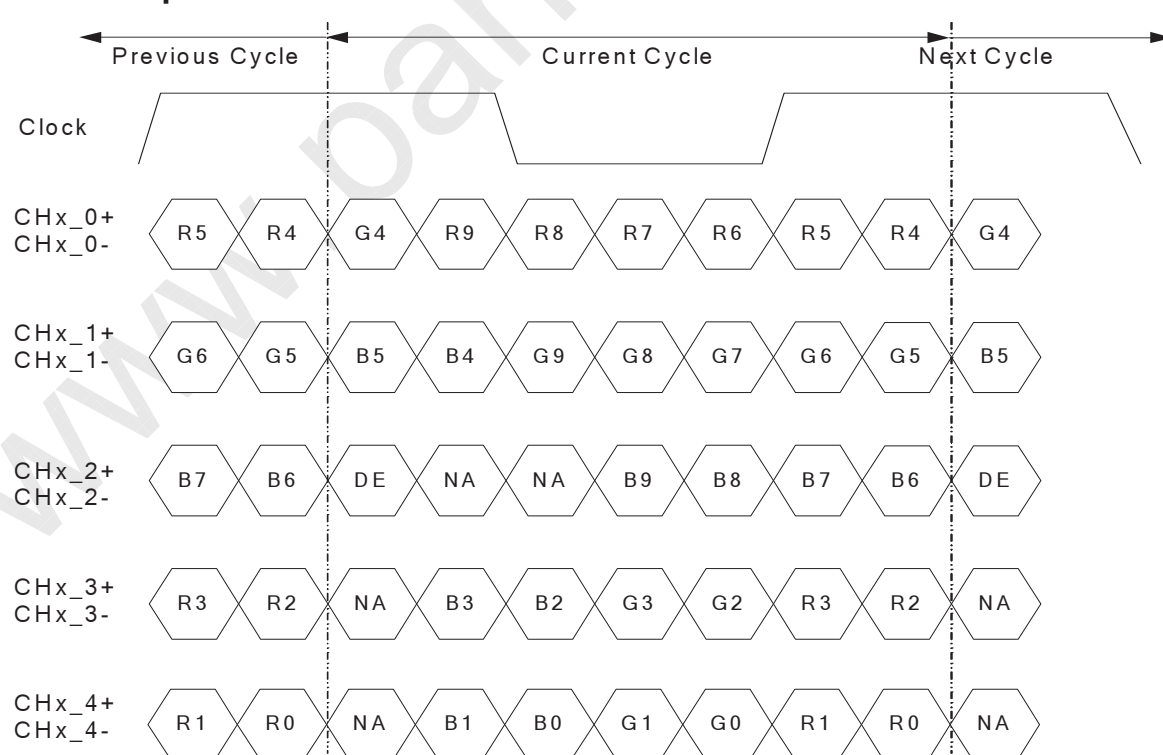

Note: x = 1, 2, 3, 4...

3.3 SIGNAL TIMING SPECIFICATION

This is the signal timing required at the input of the user connector. All of the interface signal timing should be satisfied with the following specifications for its proper operation.

Timing Table (DE only Mode)

Signal	Item	Symbol	Min.	Typ.	Max	Unit
Vertical Section	Period	Tv	1100	1125	1480	Th
	Active	Tdisp (v)	1080			
	Blanking	Tblk (v)	20	45	400	Th
Horizontal Section	Period	Th	1030	1100	1325	Tclk
	Active	Tdisp (h)	960			
	Blanking	Tblk (h)	70	140	365	Tclk
Clock	Frequency	Fclk=1/Tclk	53	74.25	82	MHz
Vertical Frequency	Frequency	Fv	47	60	63	Hz
Horizontal Frequency	Frequency	Fh	60	67.5	73	KHz

Notes:

(1) Display position is specific by the rise of DE signal only.

Horizontal display position is specified by the rising edge of 1st DCLK after the rise of 1st DE, is displayed on the left edge of the screen.

(2) Vertical display position is specified by the rise of DE after a "Low" level period equivalent to eight times of horizontal period. The 1st data corresponding to one horizontal line after the rise of 1st DE is displayed at the top line of screen.

(3) If a period of DE "High" is less than 1920 DCLK or less than 1080 lines, the rest of the screen displays black.

(4) The display position does not fit to the screen if a period of DE "High" and the effective data period do not synchronize with each other.

3.4 SIGNAL TIMING WAVEFORMS

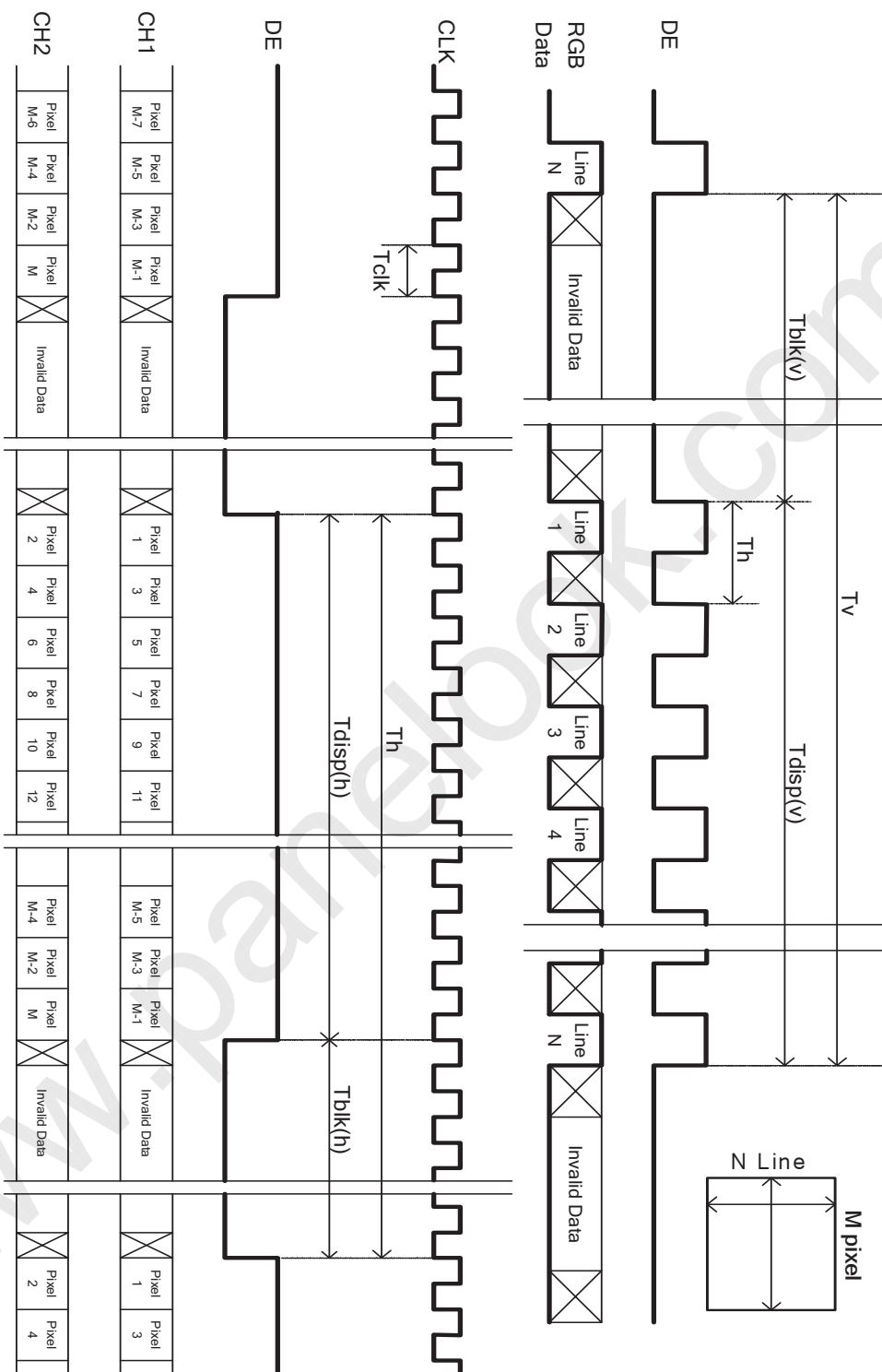

3.5 COLOR INPUT DATA REFERENCE

The brightness of each primary color (red, green and blue) is based on the 10 bit gray scale data input for the color; the higher the binary input, the brighter the color. The table below provides a reference for color versus data input.

COLOR DATA REFERENCE

Color		Input Color Data																													
		RED										GREEN										BLUE									
		MSB					LSB					MSB					LSB					MSB					LSB				
		R9	R8	R7	R6	R5	R4	R3	R2	R1	R0	G9	G8	G7	G6	G5	G4	G3	G2	G1	G0	B9	B8	B7	B6	B5	B4	B3	B2	B1	B0
Basic Color	Black	0	0	0	0	0	0	0	0	0	0	0	0	0	0	0	0	0	0	0	0	0	0	0	0	0	0	0	0	0	0
	Red(1023)	1	1	1	1	1	1	1	1	1	1	0	0	0	0	0	0	0	0	0	0	0	0	0	0	0	0	0	0	0	0
	Green(1023)	0	0	0	0	0	0	0	0	0	0	1	1	1	1	1	1	1	1	1	1	0	0	0	0	0	0	0	0	0	0
	Blue(1023)	0	0	0	0	0	0	0	0	0	0	0	0	0	0	0	0	0	0	0	0	1	1	1	1	1	1	1	1	1	1
	Cyan	0	0	0	0	0	0	0	0	0	0	1	1	1	1	1	1	1	1	1	1	1	1	1	1	1	1	1	1	1	1
	Magenta	1	1	1	1	1	1	1	1	1	1	0	0	0	0	0	0	0	0	0	0	1	1	1	1	1	1	1	1	1	1
	Yellow	1	1	1	1	1	1	1	1	1	1	1	1	1	1	1	1	1	1	1	1	0	0	0	0	0	0	0	0	0	0
	White	1	1	1	1	1	1	1	1	1	1	1	1	1	1	1	1	1	1	1	1	1	1	1	1	1	1	1	1	1	1
R	RED(000)	0	0	0	0	0	0	0	0	0	0	0	0	0	0	0	0	0	0	0	0	0	0	0	0	0	0	0	0	0	
	RED(001)	0	0	0	0	0	0	0	0	1	0	0	0	0	0	0	0	0	0	0	0	0	0	0	0	0	0	0	0	0	

	RED(1022)	1	1	1	1	1	1	1	1	0	0	0	0	0	0	0	0	0	0	0	0	0	0	0	0	0	0	0	0	0	
	RED(1023)	1	1	1	1	1	1	1	1	1	0	0	0	0	0	0	0	0	0	0	0	0	0	0	0	0	0	0	0	0	
G	GREEN(000)	0	0	0	0	0	0	0	0	0	0	0	0	0	0	0	0	0	0	0	0	0	0	0	0	0	0	0	0	0	
	GREEN(001)	0	0	0	0	0	0	0	0	0	0	0	0	0	0	0	0	0	0	1	0	0	0	0	0	0	0	0	0	0	

	GREEN(1022)	0	0	0	0	0	0	0	0	0	1	1	1	1	1	1	1	1	1	0	0	0	0	0	0	0	0	0	0	0	
	GREEN(1023)	0	0	0	0	0	0	0	0	0	1	1	1	1	1	1	1	1	1	1	0	0	0	0	0	0	0	0	0	0	
B	BLUE(000)	0	0	0	0	0	0	0	0	0	0	0	0	0	0	0	0	0	0	0	0	0	0	0	0	0	0	0	0	0	
	BLUE(001)	0	0	0	0	0	0	0	0	0	0	0	0	0	0	0	0	0	0	0	0	0	0	0	0	0	0	0	0	1	

	BLUE(1022)	0	0	0	0	0	0	0	0	0	0	0	0	0	0	0	0	0	0	0	1	1	1	1	1	1	1	1	1	0	
	BLUE(1023)	0	0	0	0	0	0	0	0	0	0	0	0	0	0	0	0	0	0	0	1	1	1	1	1	1	1	1	1	1	

3.6 POWER SEQUENCE FOR LCD

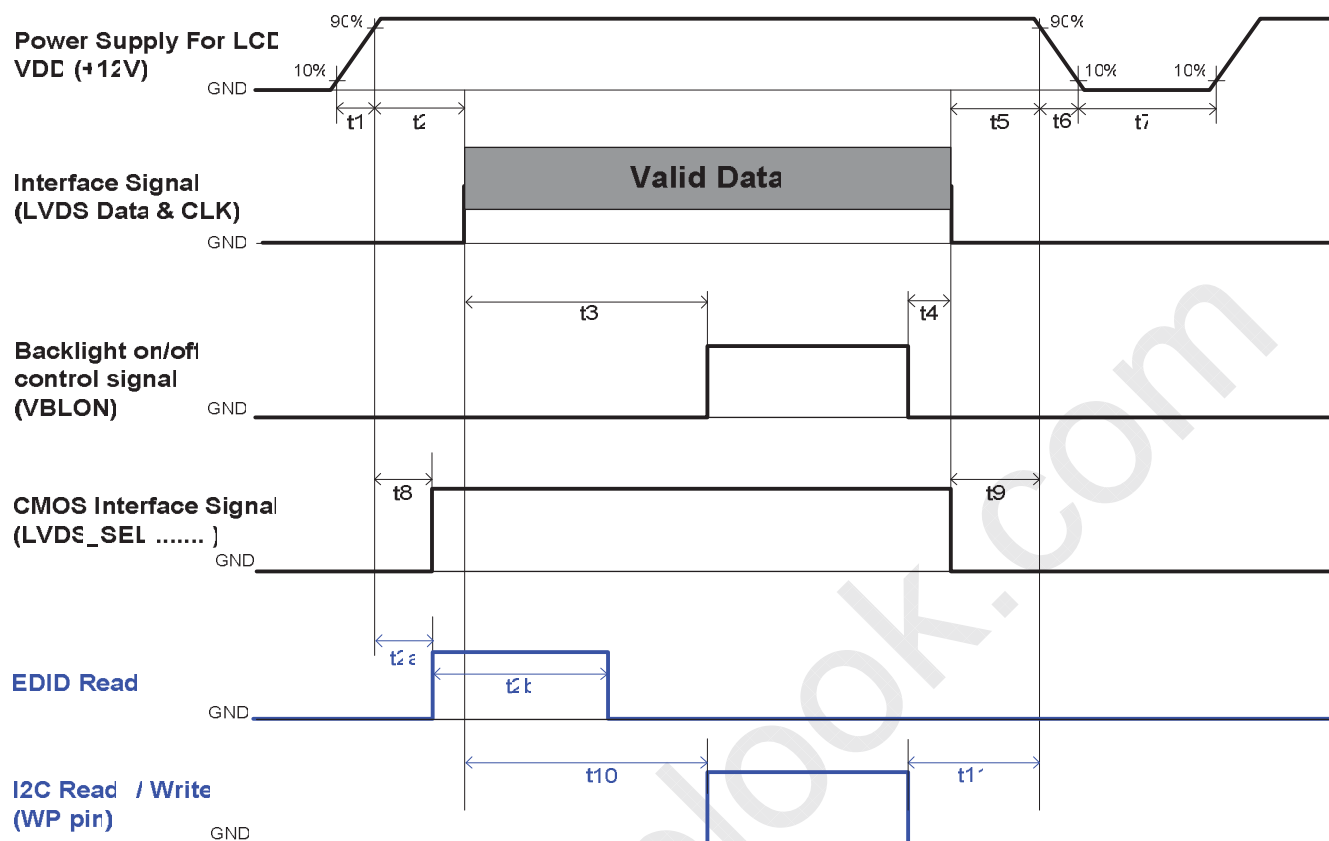

Parameter	Values			Unit
	Min.	Type.	Max.	
t1	0.4	---	30	ms
t2	0.1	---	50	ms
t3	450	---	---	ms
t4	0 ^{*1}	---	---	ms
t5	0	---	---	ms
t6	---	---	--- ^{*2}	ms
t7	500	---	---	ms
t8	10 ^{*3}	---	50	ms
t9	0	---	---	ms
t10	450	---	---	ms
t11	150	---	---	ms
t2a	10	---	50	ms
t2b	0	---	100	ms

Note:

- (1) t4=0 : concern for residual pattern before BLU turn off.
- (2) t6 : voltage of VDD must decay smoothly after power-off. (customer system decide this value)
- (3) When CMOS Interface signal is N.C. (no connection), opened in Transmitted end, t8 timing spec can be negligible.

3.7 VCOM ADJUST SOP

3.7.1 VCOM I2C TUNING STEP

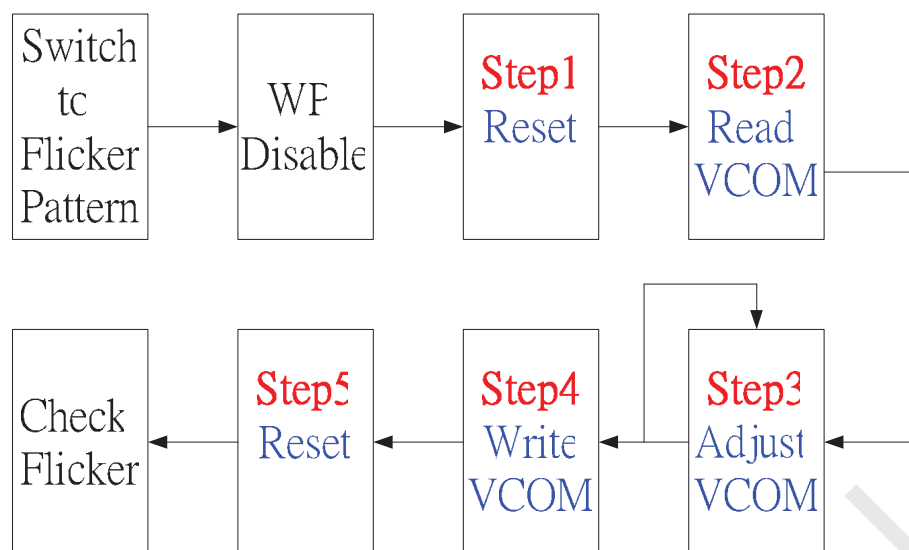

3.7.2 FLICKER PATTERN

<input checked="" type="checkbox"/> Dot Green (L128)	<input type="checkbox"/> 1+2Dot Green (L128)	<input type="checkbox"/> 2Dot Green (L128)	<input type="checkbox"/> V-stripe Green (L128)
			

3.7.3 WP (WRITE PROTECT) DISABLE

	Disable	Enable	Default (NC)
<input type="checkbox"/>	L	H	H
<input checked="" type="checkbox"/>	H	L	L

3.7.4 ADJUST SOP

Step1 Reset

* Device Address is 0x74 (7Bits)

S	Slave Address	W	A	Index Address C	A	Control Byte	A	F
	1 1 1 0 1 0 0 C			0 0 0 0 0 0 0		0 0 0 1 0 0 1 0		
	0xE8			0x00		0x12		
	Device Address + W			Control Address		Reset + OUT_EN		

Step2 Read VCOM

* Data = 7Bits

S	Slave Address	W	A	Index Address 1	A	S	Slave Address	R	A	DATA	NA	F
	1 1 1 0 1 0 C C			0 0 0 0 0 0 0 1			1 1 1 0 1 0 C 1			X X X X X X X X		
	0xE8			0x01			0xE9					
	Device Address + W			VCOM Address			Device Address + R			Data		

Step3 Adjust VCOM

* DVCOM = 8Bits

S	Slave Address	W	A	Index Address 1	A	DVCOM	A	F
	1 1 1 0 1 0 C C			0 0 0 0 0 0 0 1		0000000X~1111111X		
	0xE8			0x01		0x00~0xFF		
	Device Address + W			VCOM Address		VCOM value		

Step4 Write VCOM

S	Slave Address	W	A	Index Address 0	A	Control Byte	A	F
	1 1 1 0 1 0 C C			0 0 0 0 0 0 0 C		0 0 0 0 1 0 1 0		
	0xE8			0x0C		0x1C		
	Device Address + W			Control Address		Write DAC to NVM+ OUT_EN		

Step5 Reset

* Device Address is 0x74 (7Bits)

S	Slave Address	W	A	Index Address C	A	Control Byte	A	F
	1 1 1 0 1 0 0 C			0 0 0 0 0 0 0 0		0 0 0 1 0 0 1 0		
	0xE8			0x00		0x12		
	Device Address + W			Control Address		Reset + OUT_EN		

3.7.5 INTERVAL OF STEP TO STEP

Step to step interval must follow below figure

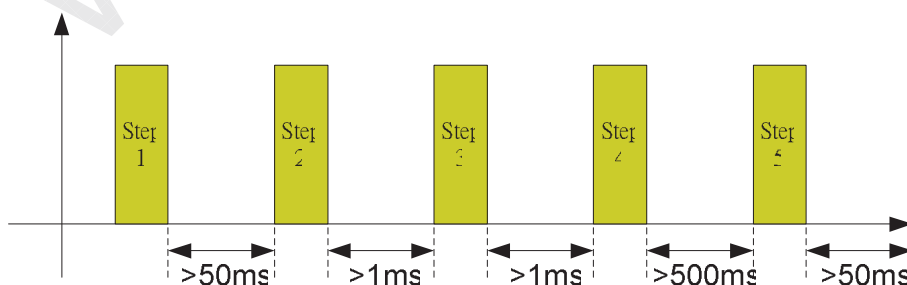

4. OPTICAL SPECIFICATION

Optical characteristics are determined after the open cell unit and light source has been 'ON' and stable for approximately 45 minutes in a dark environment at 25°C. The values specified are at an approximate distance 50cm from the LCD surface at a viewing angle of ϕ and θ equal to 0°.

Fig.1 presents additional information concerning the measurement equipment and method.

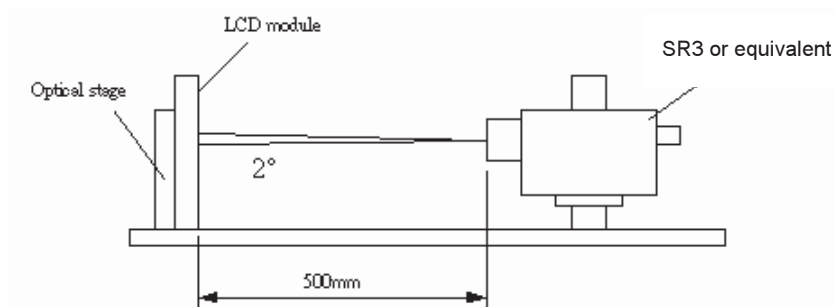

Parameter	Symbol	Condition	Values			Unit	Notes
			Min.	Typ.	Max		
Contrast Ratio	CR	With AUO Module	3200	4000	--		1, 2
White Variation	$\delta_{\text{WHITE}(9P)}$		--	--	1.33		1, 3
Response Time (G to G)	T_{γ}		--	6.5	--	Ms	4
Center Transmittance	T%			5.7(TBD)		%	1, 7
Color Chromaticity		With CS-1000T Standard light source "C"	Typ.-0.03		Typ.+0.03		5
Red	R_x			0.660			
	R_y			0.325			
Green	G_x			0.304			
	G_y			0.596			
Blue	B_x			0.137			
	B_y			0.093			
White	W_x			0.312			
	W_y	0.358					
Viewing Angle		With AUO Module					1, 6
x axis, right($\phi=0^\circ$)	θ_r		--	89	--	degree	
x axis, left($\phi=180^\circ$)	θ_l		--	89	--	degree	
y axis, up($\phi=90^\circ$)	θ_u		--	89	--	degree	
y axis, down ($\phi=270^\circ$)	θ_d		--	89	--	degree	

- Light source here is the BLU of AUO T420HVD02.0 module.
- Contrast Ratio (CR) is defined mathematically as:

$$\text{Contrast Ratio} = \frac{\text{Surface Luminance of } L_{\text{on5}}}{\text{Surface Luminance of } L_{\text{off5}}}$$

3. The white variation, δ_{WHITE} is defined as:

$$\delta_{\text{WHITE(9P)}} = \text{Maximum}(L_{\text{on1}}, L_{\text{on2}}, \dots, L_{\text{on9}}) / \text{Minimum}(L_{\text{on1}}, L_{\text{on2}}, \dots, L_{\text{on9}})$$

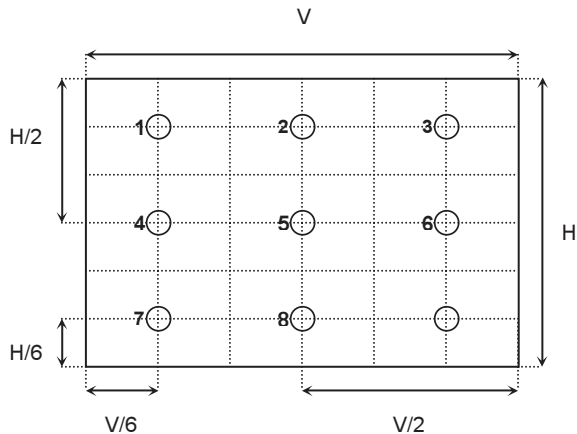

4. Response time T_r is the average time required for display transition by switching the input signal for five luminance ratio (0%,25%,50%,75%,100% brightness matrix) and is based on $F_v=60\text{Hz}$ to optimize.

Measured Response Time		Target				
		0%	25%	50%	75%	100%
Start	0%		0% to 25%	0% to 50%	0% to 75%	0% to 100%
	25%	25% to 0%		25% to 50%	25% to 75%	25% to 100%
	50%	50% to 0%	50% to 25%		50% to 75%	50% to 100%
	75%	75% to 0%	75% to 25%	75% to 50%		75% to 100%
	100%	100% to 0%	100% to 25%	100% to 50%	100% to 75%	

The response time is defined as the following figure and shall be measured by switching the input signal for “any level of gray(bright)” and “any level of gray(dark)”.

FIG.3 Response Time

Any level of gray (Bright)

Any level of gray (Dark)

Any level of gray (Bright)

Any level of gray (Bright)

Any level of gray (Dark)

Any level of gray (Bright)

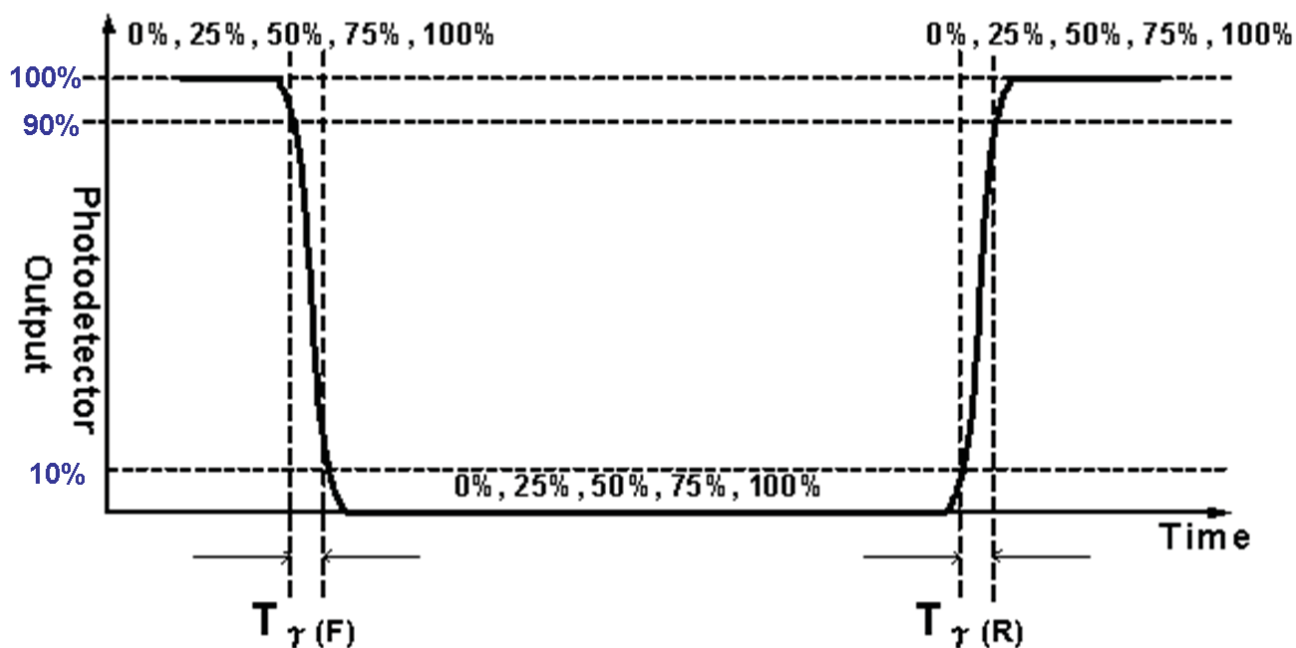

5. Light source here is the standard light source "C" which is defined by CIE and driving voltages are based on suitable gamma voltages. The calculating method is as following :
 - A. Measure the "Module" and "BLU" optical spectrums (W, R, G, B).
 - B. Calculate cell spectrum from "Module" and "BLU" spectrums.
 - C. Calculate color chromaticity by using cell spectrum and the spectrum of standard light source "C".
6. Viewing angle is the angle at which the contrast ratio is greater than 10. The angles are determined for the horizontal or x axis and the vertical or y axis with respect to the z axis which is normal to the LCD surface. For more information see FIG4.

FIG.4 Viewing Angle

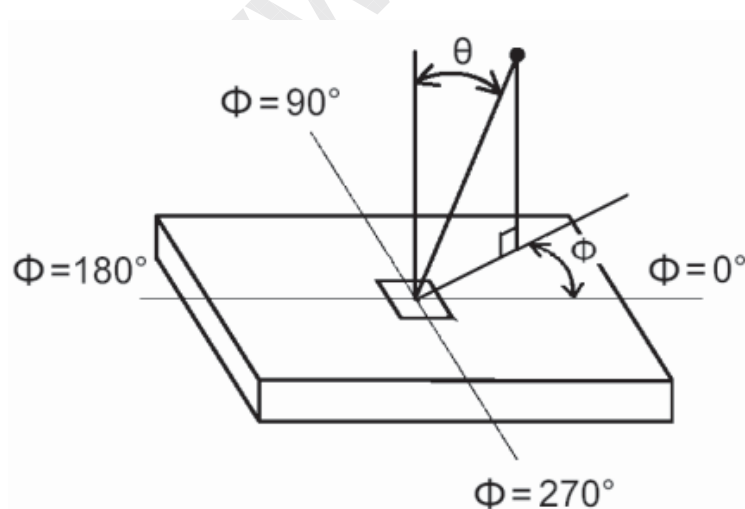

7. Definition of Transmittance (T%):

$$\text{Transmittance} = \frac{\text{Luminance of LCD module}}{\text{Luminance of backlight}} * 100\%$$

During transmittance measurement, the backlight of LCD module contains no brightness enhancement film. Two diffuser sheets which diffuse the light source uniformly are suggested to use for transmittance measurement.

5. MECHANICAL CHARACTERISTICS

TBD

www.panelook.com

6. PACKING

Open cell shipping label (35*7mm)



1. S/N Number
2. AUO internal use
3. Manufactured week
4. Model name

Carton Label:

AU Optronics	RoHS	Pb	
MODEL NO: T420HVN04.3			
PART NO: 91.42T28.3XX			
CUSTOMER NO: XXXXX-XXXXX-XXXXX			
CARTON NO:			
Made in XXXXXX	*XXXXXX-XXXXXXXXXX*		

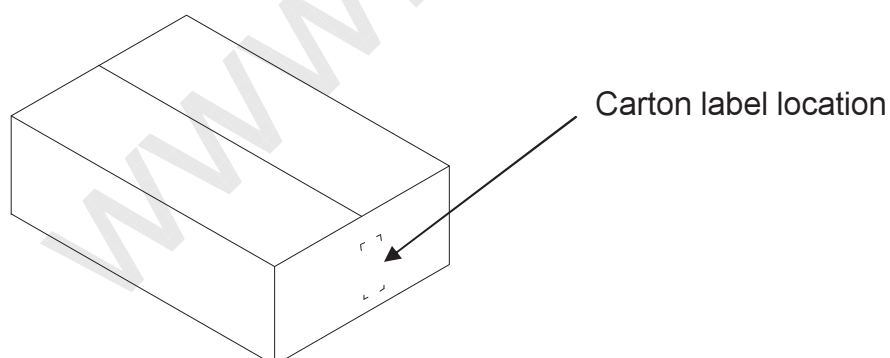

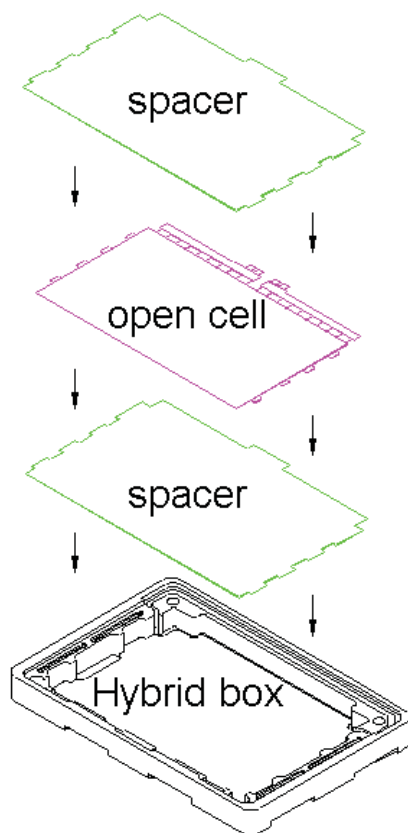
Packing Process:

Box for 10 pcs open cells & 11 pcs spacers

EPP Top Cover

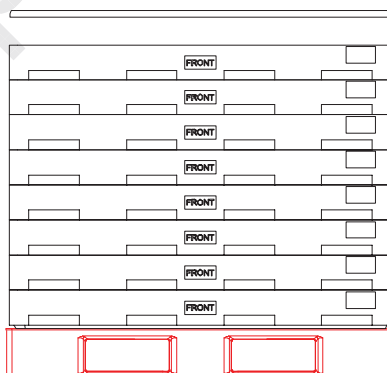

Pallet Dimension: 1100*800*140 mm

8 Boxes/Pallet, after stack 8 boxes, then put EPP top cover on it.

7. PRECAUTIONS

Please pay attention to the followings when you use this TFT LCD Open Cell unit.

7.1 MOUNTING PRECAUTIONS

- (1) You should consider the mounting structure so that uneven force (ex. Twisted stress) is not applied to the cell. And the frame on which a cell is mounted should have sufficient strength so that external force is not transmitted directly to the cell.
- (2) Please attach the surface transparent protective plate to the surface in order to protect the polarizer. Transparent protective plate should have sufficient strength in order to resist external force.
- (3) You should adopt radiation structure to satisfy the temperature specification.
- (3) Acetic acid type and chlorine type materials for the cover case are not desirable because the former generates corrosive gas of attacking the polarizer at high temperature and the latter causes circuit break by electro-chemical reaction.
- (4) Do not touch, push or rub the exposed polarizers with glass, tweezers or anything harder than HB pencil lead. And please do not rub with dust clothes with chemical treatment. Do not touch the surface of polarizer for bare hand or greasy cloth. (Some cosmetics are detrimental to the polarizer.)
- (5) When the surface becomes dusty, please wipe gently with absorbent cotton or other soft materials like chamois soaks with petroleum benzene. Normal-hexane is recommended for cleaning the adhesives used to attach front/ rear polarizers. Do not use acetone, toluene and alcohol because they cause chemical damage to the polarizer.
- (6) Wipe off saliva or water drops as soon as possible. Their long time contact with polarizer causes deformations and color fading.
- (7) Do not open the case because inside circuits do not have sufficient strength.

7.2 OPERATING PRECAUTIONS

- (1) The open cell unit listed in the product specification sheets was designed and manufactured for TV application
- (2) The spike noise causes the mis-operation of circuits. It should be lower than following voltage:
 $V = \pm 200\text{mV}$ (Over and under shoot voltage)
- (3) Response time depends on the temperature. (In lower temperature, it becomes longer.)
- (4) Brightness/transmittance depends on the temperature. (In lower temperature, it becomes lower.) And in lower temperature, response time (required time that brightness is stable after turned on) becomes longer.
- (5) Be careful for condensation at sudden temperature change. Condensation makes damage to polarizer or electrical contacted parts. And after fading condensation, smear or spot will occur.
- (6) When fixed patterns are displayed for a long time, remnant image is likely to occur.
- (7) Module has high frequency circuits. Sufficient suppression to the electromagnetic interference shall be done by system manufacturers. Grounding and shielding methods may be important to minimize the interface.

7.3 ELECTROSTATIC DISCHARGE CONTROL

Since a open cell unit is composed of electronic circuits, it is not strong to electrostatic discharge. Make certain that treatment persons are connected to ground through wrist band etc. And don't touch interface pin directly.

7.4 PRECAUTIONS FOR STRONG LIGHT EXPOSURE

Strong light exposure causes degradation of polarizer and color filter.

7.5 STORAGE

When storing open cell units as spares for a long time, the following precautions are necessary.

- (1) Store them in a dark place. Do not expose the open cell unit to sunlight or fluorescent light. Keep the temperature between 5□ and 35□ at normal humidity.
- (2) The polarizer surface should not come in contact with any other object. It is recommended that they be stored in the container in which they were shipped.

7.6 HANDLING PRECAUTIONS FOR PROTECTION FILM OF POLARIZER

The protection film of polarizer is still attached on the surface as you receive open cell units. When the protection film is peeled off, static electricity is easily generated on the polarizer surface. This should be peeled off slowly and carefully by people who are electrically grounded and with well ion-blown equipment or in such a condition, etc.