

17 – 24 GHz GaAs Power Amplifier/Driver MMIC

- 4 Stage Monolithic Microwave Integrated Circuit (MMIC) Amplifier
- Input/Output matched (incl. bond wires)
- Frequency range: 17 GHz to 24 GHz
- High Isolation > 50 dB
- Gain > 22 dB
- $P_{-1dB} > 23$ dBm, $P_{sat} > 24$ dBm

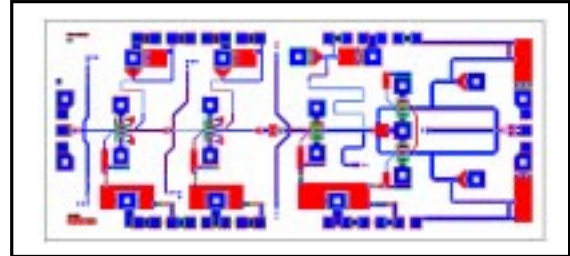

chip size: 4.2 mm x 1.8 mm

ESD: Electrical discharge sensitive device, observe handling precautions!

Description:

This 4 stage GaAs MMIC power amplifier is intended for use in radio link applications. It provides an output power of 23 dBm at 1 dB gain compression. The device is fabricated with a 0.18 micron Pseudomorphic InGaAs/AlGaAs/GaAs High Electron Mobility Transistor processing technology.

Type	Ordering Code	Package
Chip T458B	tbd	Chip

Electrical Specifications: ($V_D = 5 - 6$ V, $I_D = 300$ mA)

Parameter	Min	Typ	Max	Unit
Frequency Range	17		24	GHz
P_{-1dB}		23		dBm
Gain		22		dB
P_{sat}		24		dBm
PAE		15		%
Input Return Loss (incl. bond wire)		- 6		dB
Output Return Loss (incl. bond wire)		- 3		dB

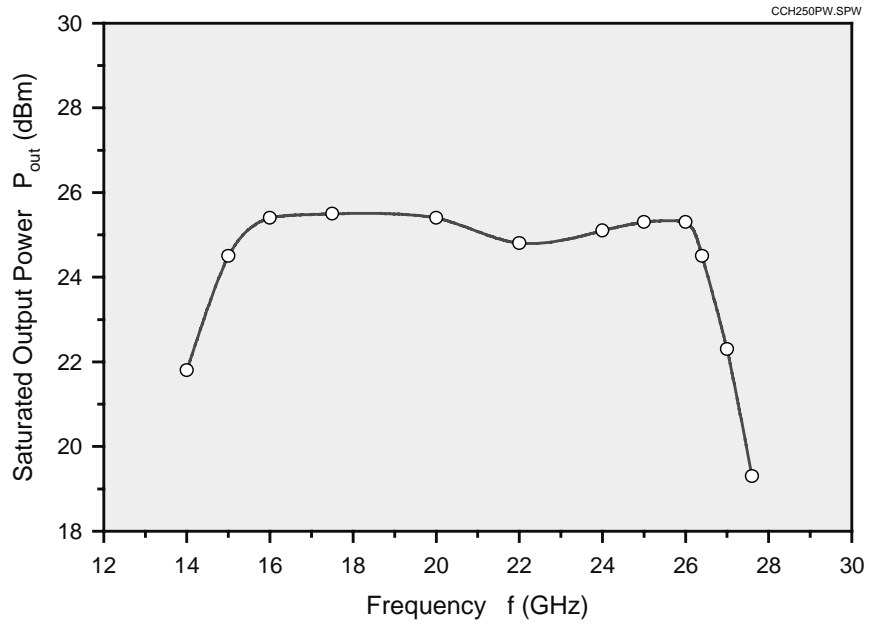
Measured data: (on chip measurements)**Application Circuit:**

tbd.

Technology data:

Chip thickness	95µm
Chip size	4,2 mm * 1,8 mm
Bond pads	100 µm * 100 µm
Bond pad material	Au (plated gold)
Chip passivation	SiN (silicon nitride)

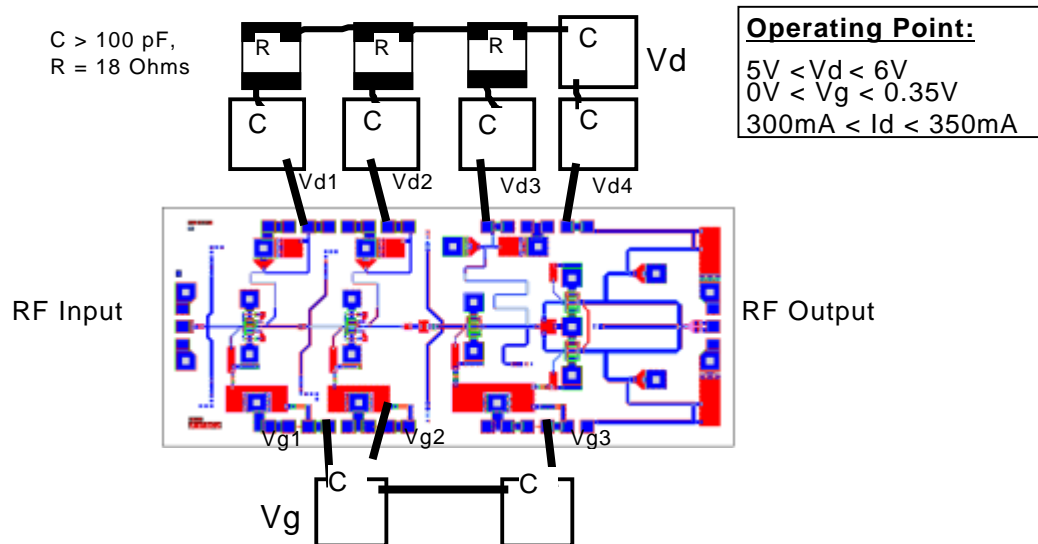
Suggested measurement setup:

Recommendation of Bonding Conditions:

	Thermocompression Nailhead, without ultrasonic	Wedge Bonding	Bond Pull Test Mil 883, >2 g
Table Temp.	250°C	250°C	1: 2,5 g 2: 3,1 g 3: 3,2 g 4: 3,0 g 5: 2,8 g
Tool Temp.	180°C	150°C	
Scrub	100 Hz		
Bond Force	50 g	25 g	
Wire Diameter	25 µm	17 µm	

Published by Infineon Technologies AG i. Gr., Wireless Products Division, GaAs & Sensor Subdivision, WS GS PM P, Balanstraße 73, 81541 Munich, Germany; Postal Address: P.O. Box 800949, 81609 Munich, Germany.

copyright Infineon Technologies 1999. All Rights Reserved.

As far as patents or other rights of third parties are concerned, liability is only assumed for components per se, not for applications, processes and circuits implemented within components or assemblies.

The information describes the type of component and shall not be considered as assured characteristics.

Terms of delivery and rights to change design reserved.

For questions on technology, delivery, and prices please contact the Offices of Infineon in Germany or the Infineon Companies and Representatives worldwide.

Due to technical requirements components may contain dangerous substances. For information on the type in question please contact your nearest Infineon Office.

Infineon Technologies AG i. Gr. is an approved QS9000 and ISO9001 manufacturer.